



DORNIER 17 M

GERMAN MEDIUM BOMBER

1:72

SCALE
PLASTIC KIT

Dornier 17 M galt im Grunde als mittlerer Bomber mit einer Bombenlast von bis max. 1000 kg. Als Motorenausstattung hatte das RLM auf zwei luftgekühlte BRAMO 323 gesetzt. Die Abwehrbewaffnung bestand aus drei MG 15. An Abwurflasten konnte die Do 17 M entweder 20 SC 50 oder zwei SC 250, aber auch zehn SC 50 und eine SC 250 mitführen. Insgesamt wurden 200 Do 17 M produziert.

The Dornier 17 M started its service career as a medium bomber able to carry a bomb load of 1000 kg. It was equipped with either two air-cooled BRAMO 323 radial engines. The defensive armament was increased to three MG 15. A payload consisting of either 20 SC 50 or two SC 250 bombs or ten SC 50 and single SC 250 could be carried. All-in-all 200 Do 17 M were produced.

Dornier 17 M byl střední bombardér s nosností 1000 kg bomb. Byl poháněn dvěma Vzduchem chlazenými motory BRAMO 323 a vyzbrojen třemi kulomety MG 15. Mohl nést 20 ks pum SC 50 nebo dvě SC 250, popř. 10 ks SC 50 a jednu SC 250. Byly používány na počátku války a později k výcviku. Později bylo několik strojů prodáno do Bulharska a do Rumunska. Celkem bylo postaveno 200 ks Do 17 M.

Span / Spanweite / Rozpětí: **18,00 m**
Length / Länge / Délka: **16,10 m**
High / Höhe / Výška: **4,55 m**
Empty weight / Leergewicht / Hm. prázdná: **5210 kg**
Loaded weight / Startgewicht / Vzl. hmotnost: **8135 kg**
Max. speed / Höchstgeschwindigkeit/ Max. rychlost: **410 km/h**
Max. ceiling / Dienstgipfelhöhe / Dostup: **6700 m**
Max. range / Reichweite / Dolet: **1360 km**
Engines / Triebwerke / Motory: **2 x BRAMO 323 A-1, 900 hp**
Crew / Besatzung / Posádka: **3**

Plastic Parts

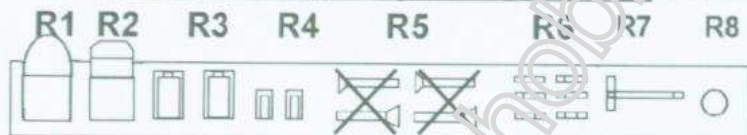
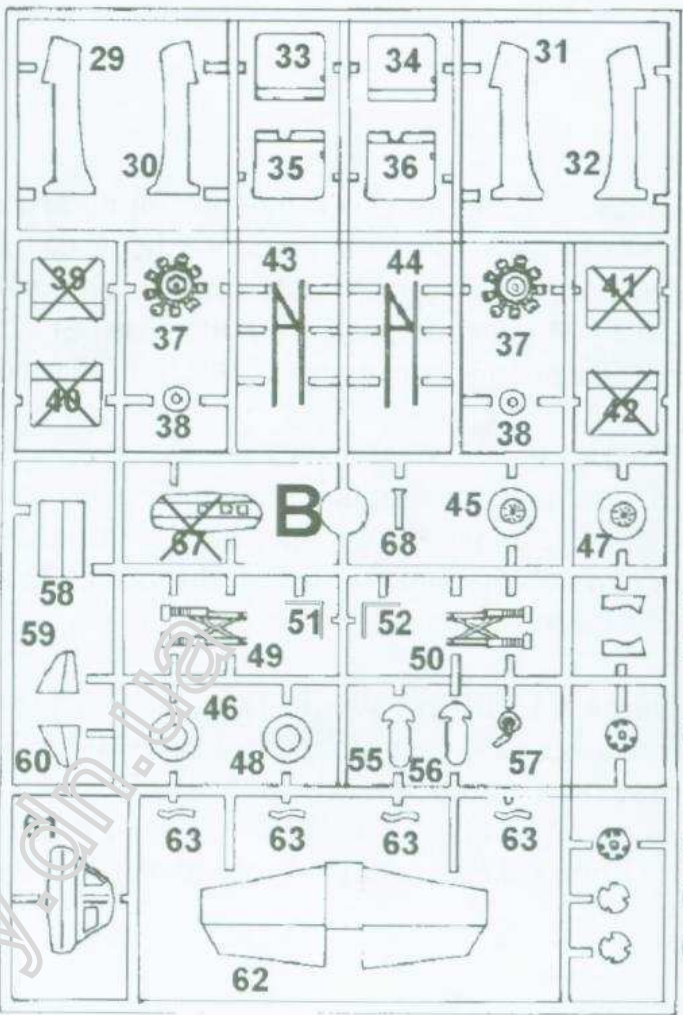
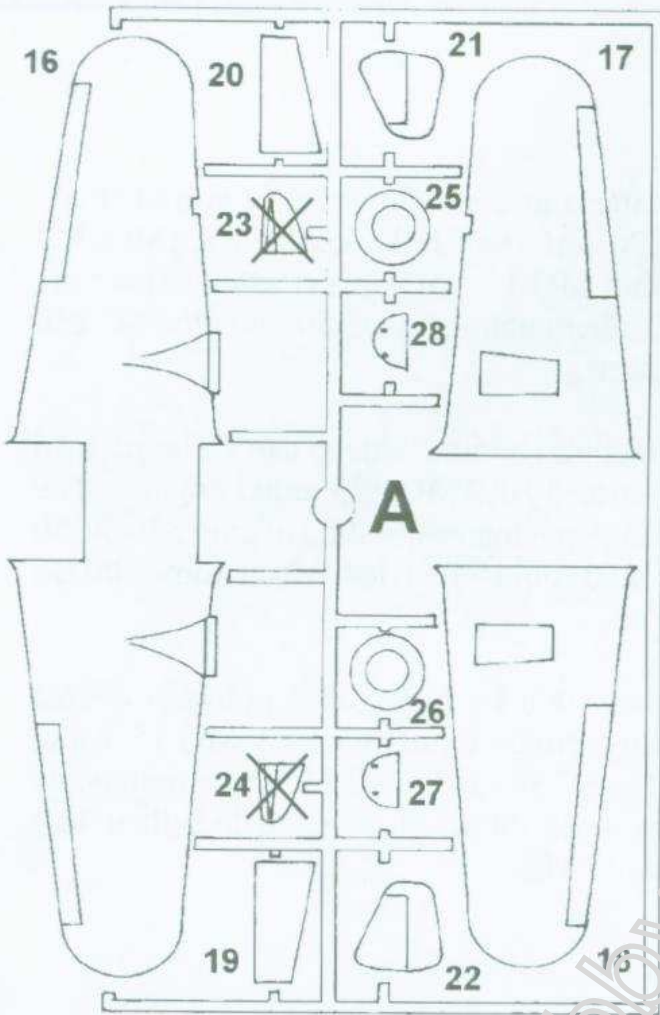

Resin Parts

Metal Parts

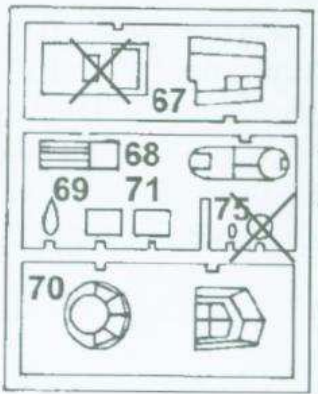
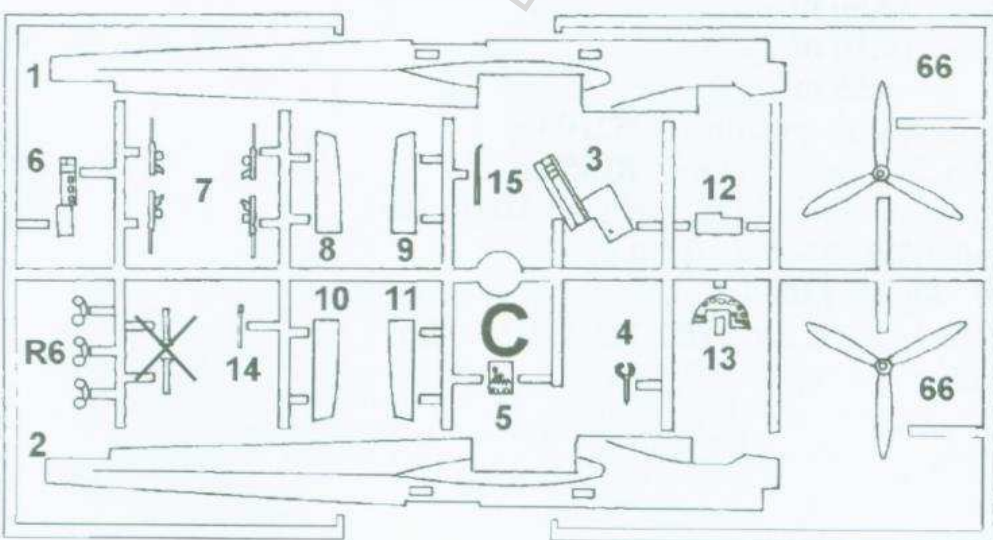

D

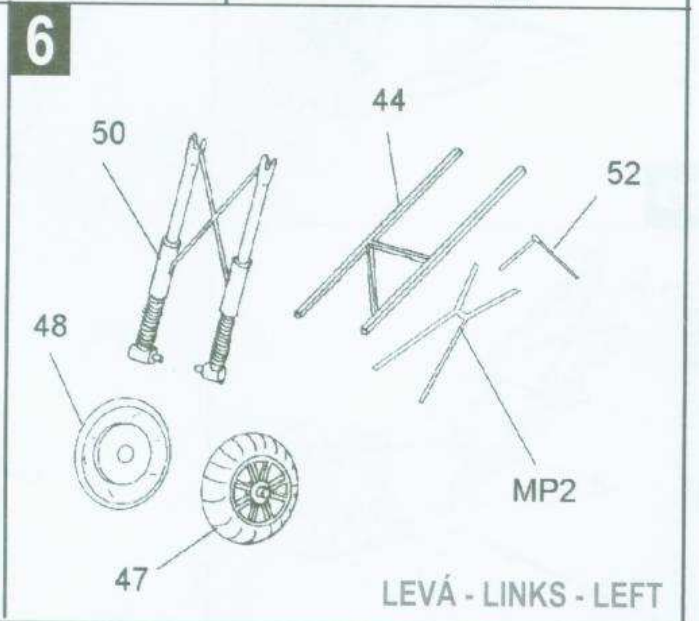
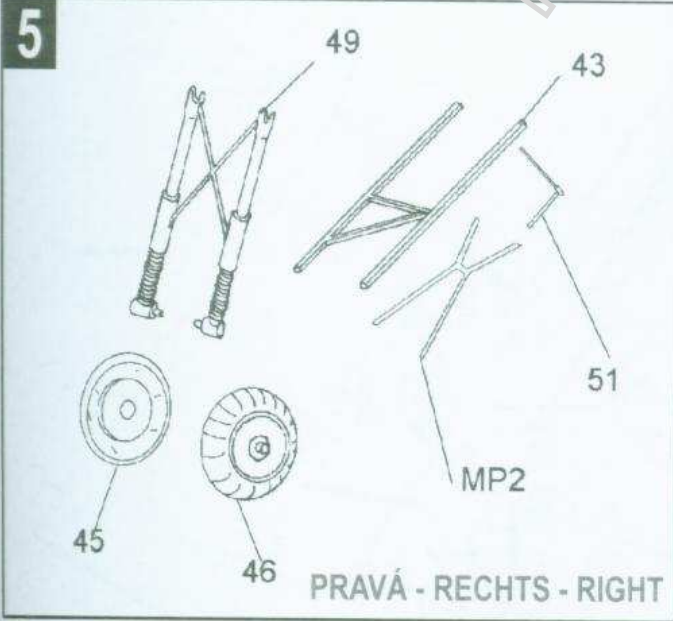
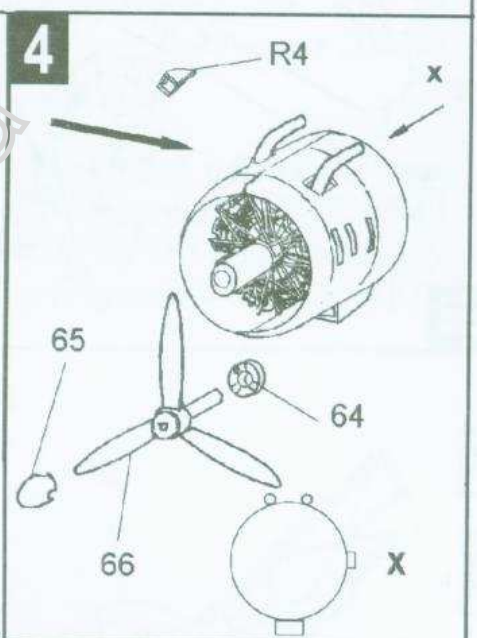
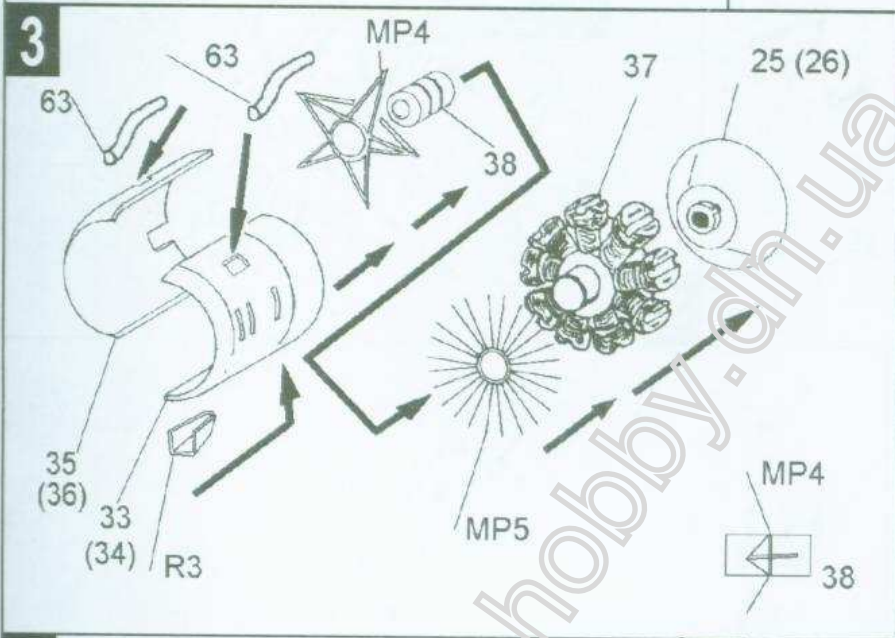
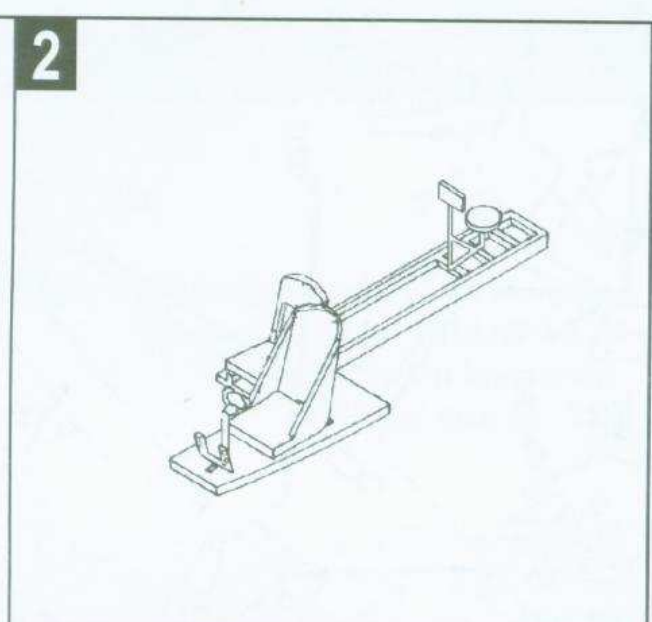
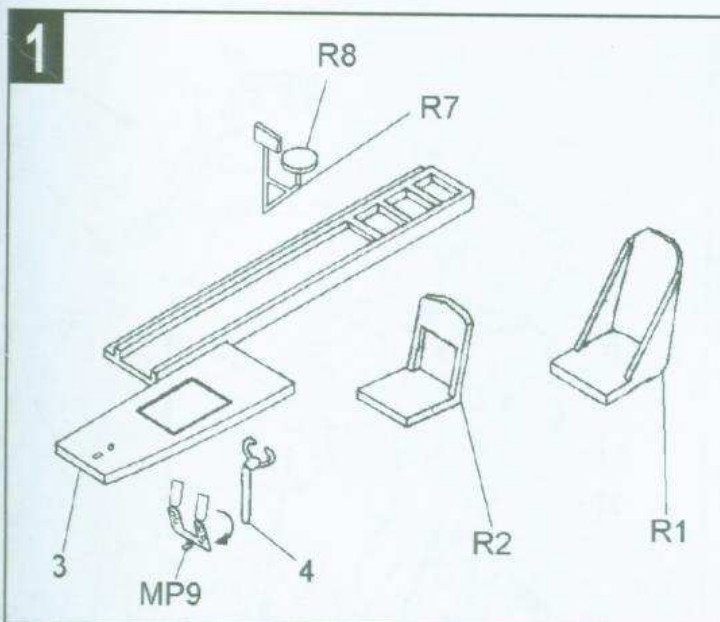

7 PRAVÁ - RECHTS - RIGHT

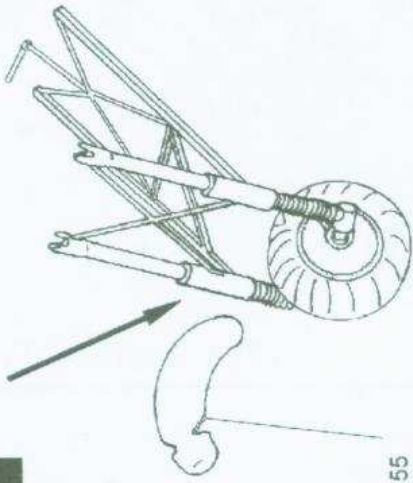

8

LEVÁ - LINKS - LEFT

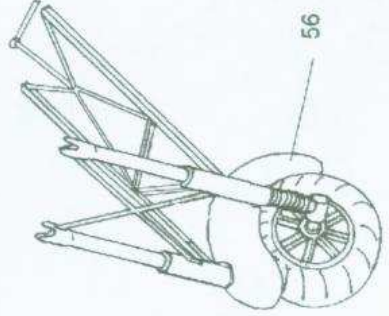

10

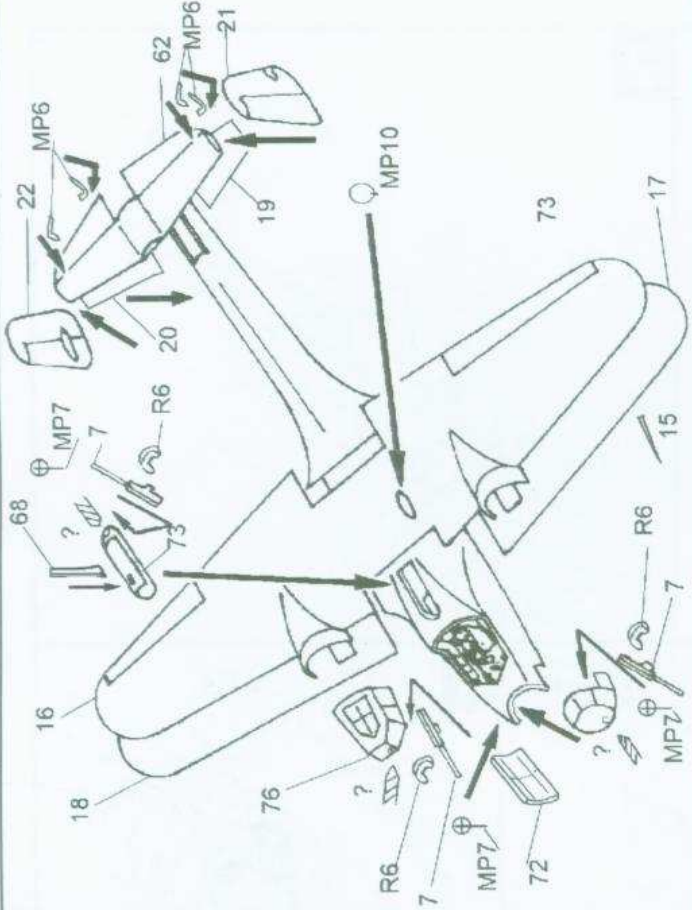

9

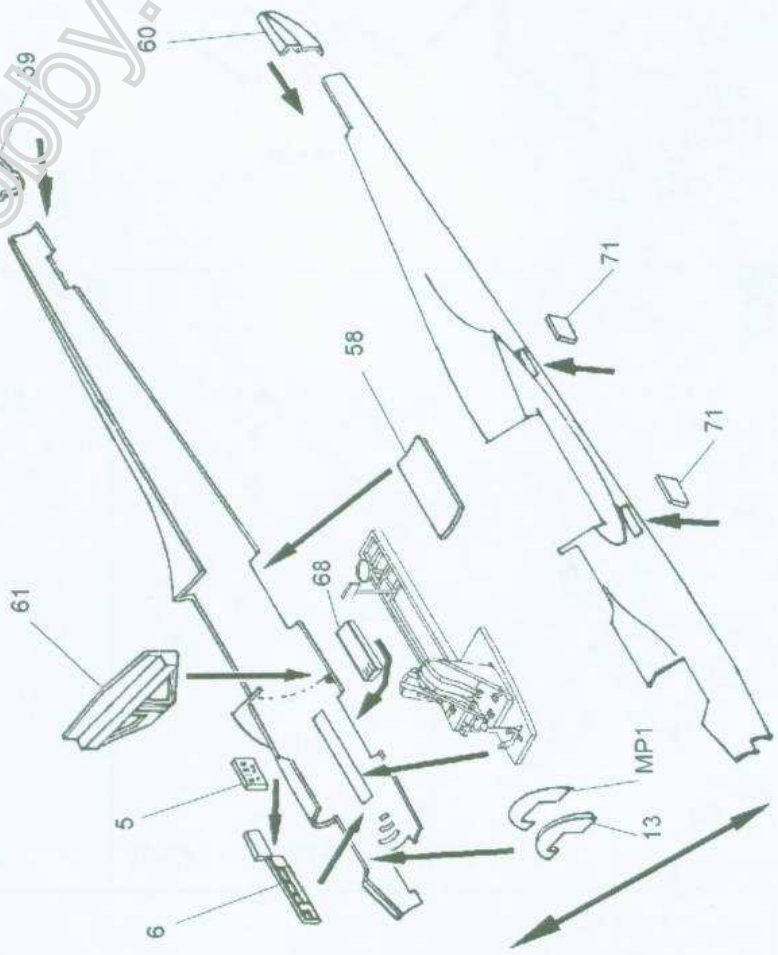

11

