

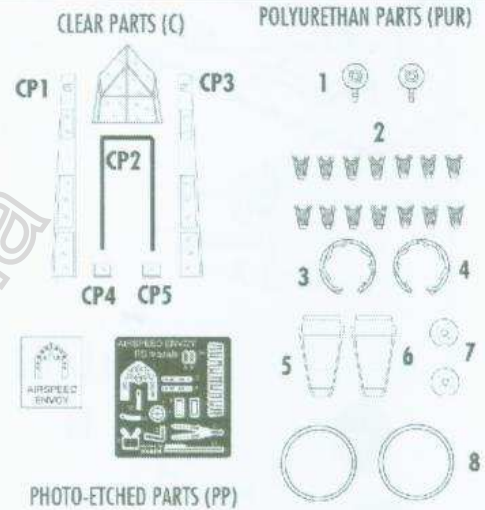

Airspeed Envoy - CASTOR engine

scale 1/72

Pilot and eight-passenger enlarged and twin-engined development of the AS.5 Courier. First flown on 26 June 1934. About 50 built by Airspeed for British, Japanese, Czechoslovakian, Chinese and South African civil operators, plus a small number for the South African Air Force and the RAF (SAAF Envoy's carrying bombs and one forward-firing and one dorsal-turreted machine-gun). Mitsubishi also built a number under licence. Engines fitted to Envoy's included the Wolseley AR.9, Scorpio I or Aries III, Armstrong Siddeley Lynx IVC or Cheetah IX, Wright Whirlwind R.760 and Walter Castor II.

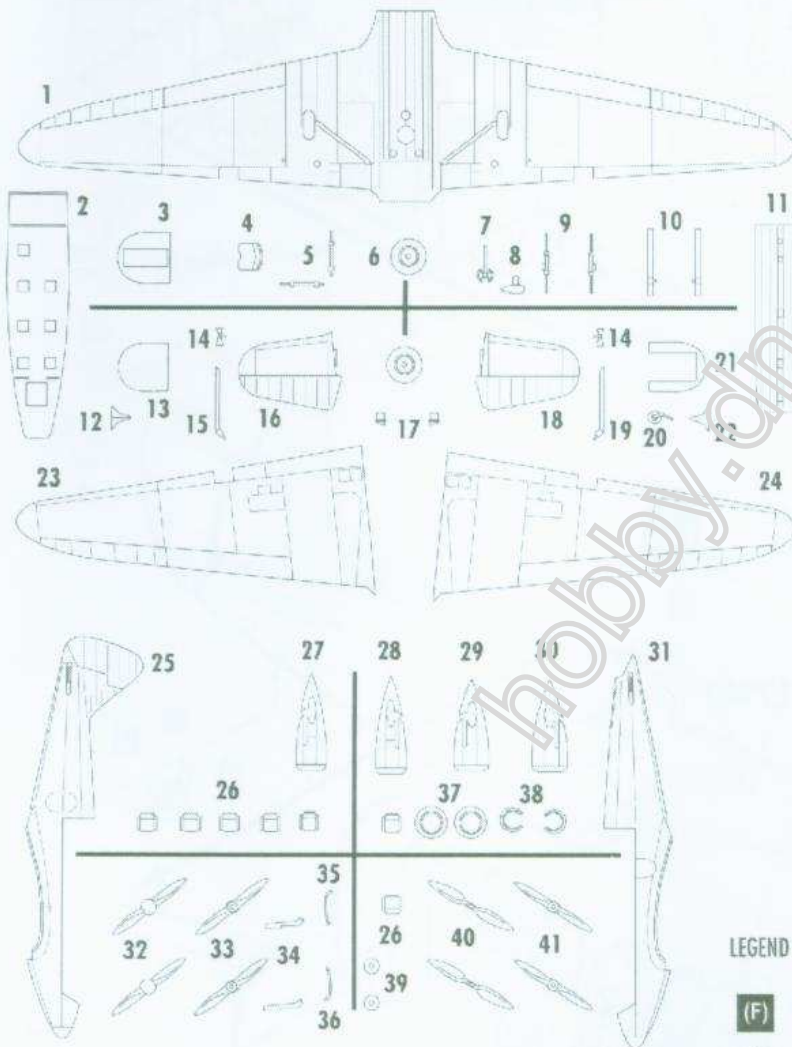

- | | | | | | | | | | |
|----------------|---|---------------------|-------------------|--------------------|---------------------------|-----------------|----------------|--|--|
| | | | | | | | | | |
| ohnout
bend | vteřinové lepidlo
cyanoacrylate glue | odstranit
remove | upravit
reduce | vřtat
open hole | vyřtobit
setchra build | obtisk
decal | barva
color | symetrická montáž
symetrical assembly | |

LEGEND

- | | |
|--|--|
| | film |
| | symetrická montáž
symetrical assembly |

COLORS

- | | | | | | | | | | | | | | |
|--|------------------------------------|--|------------------|--|-----------------------|--|--------------------|--|-----------------|--|---------------------------|--|-------------------------|
| | Černá
Black | | Sřivně
Silver | | Kuže
Leather | | Chromová
Chrome | | Bělá
White | | Pneumatiky
Tyres Black | | Temně šedá
Dark Grey |
| | Interiér, zelená
Interior Green | | Plátno
Linen | | Hřniková
Aluminium | | Červená
Red | | Žlutá
Yellow | | Rezavá
Rust | | Kovová
Gun metal |

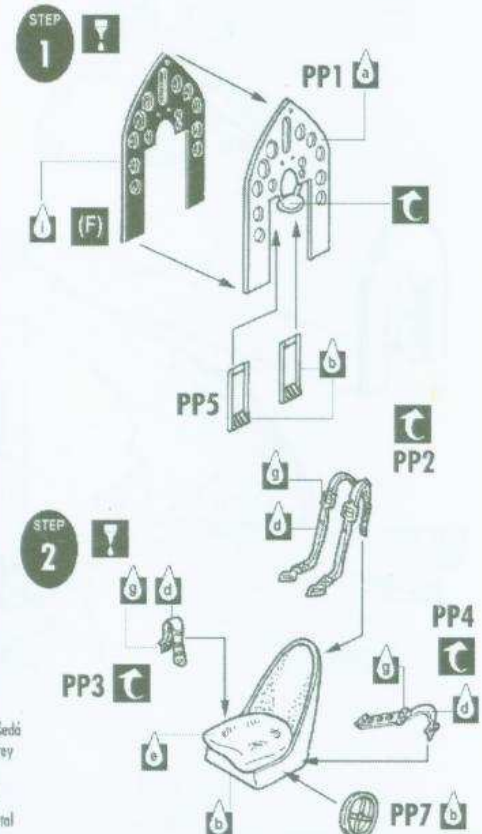

92098

STEP 3

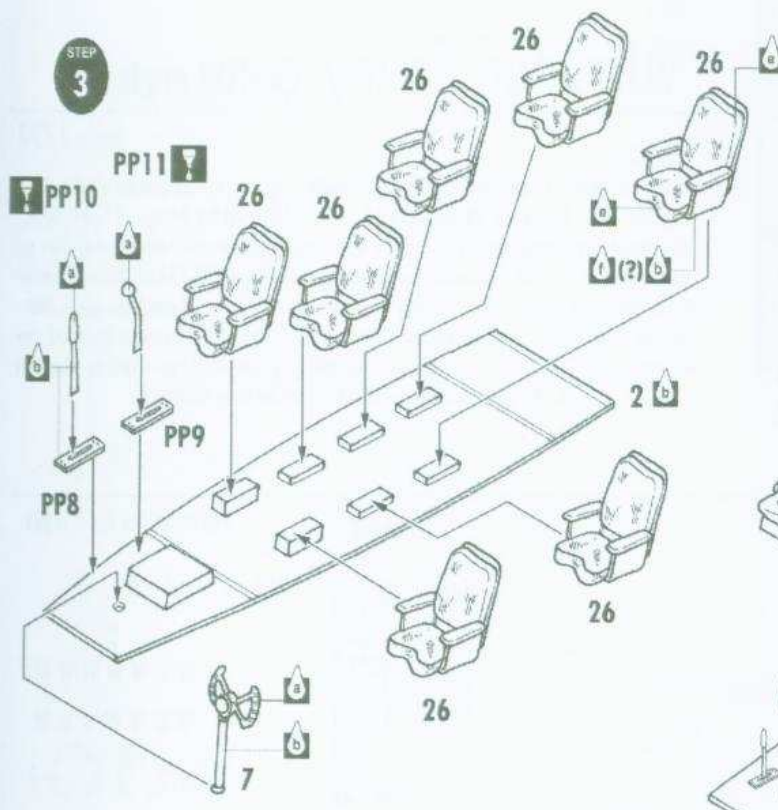

STEP 4

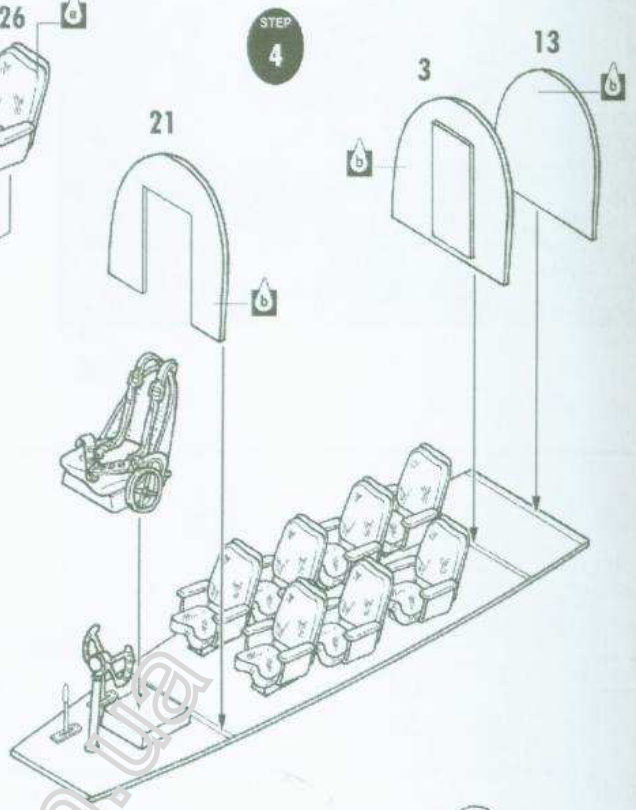

STEP 5

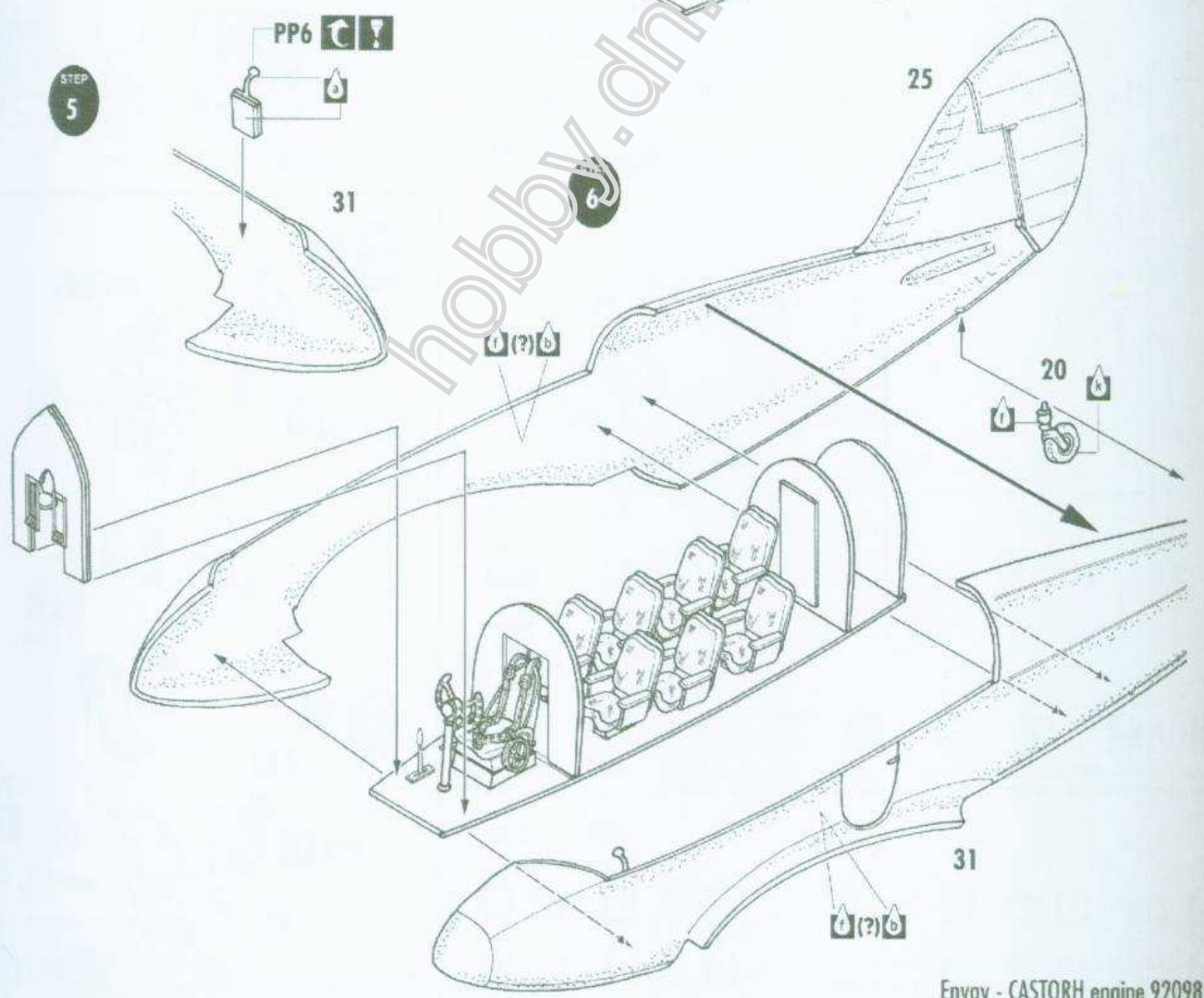

STEP 7

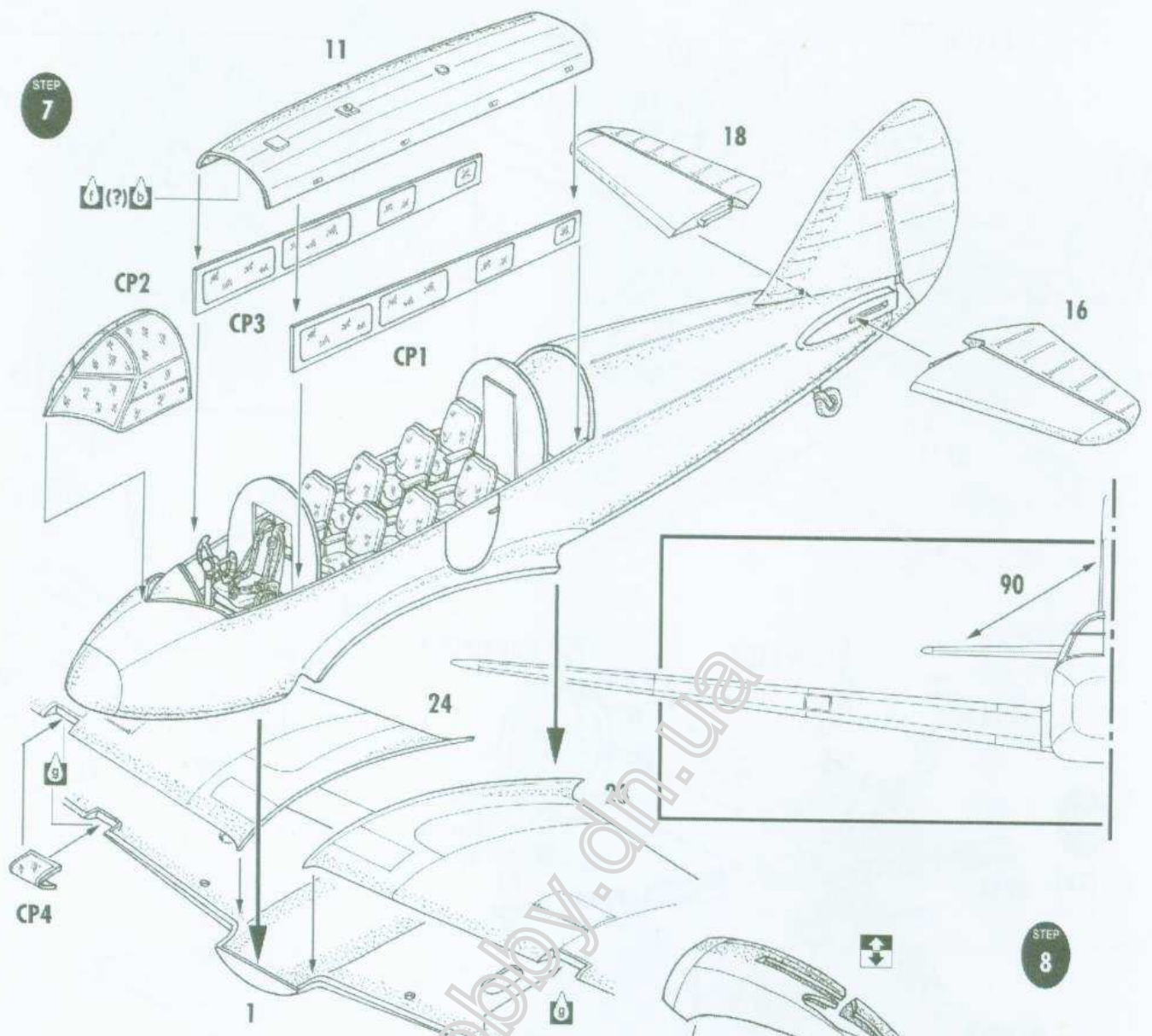

STEP 8

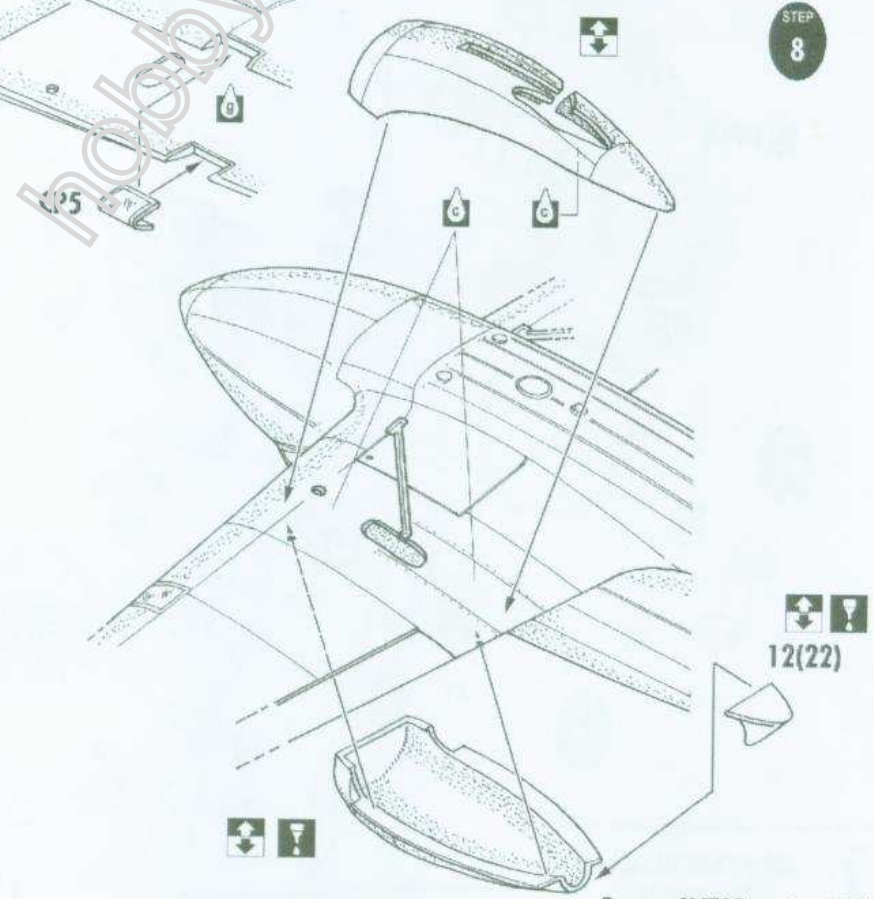

Envoy - CASTOR engine 92098

15 (19)

STEP 9

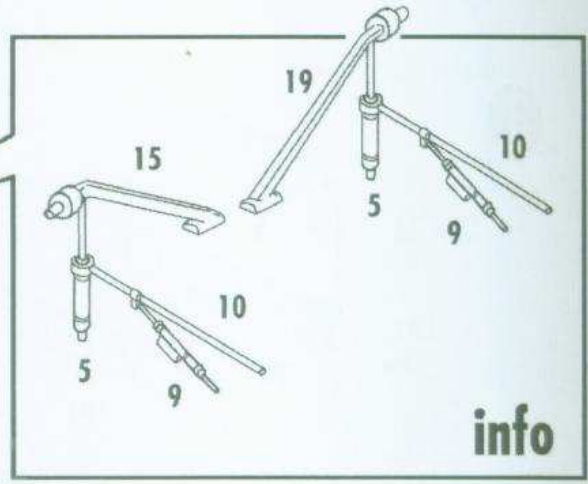
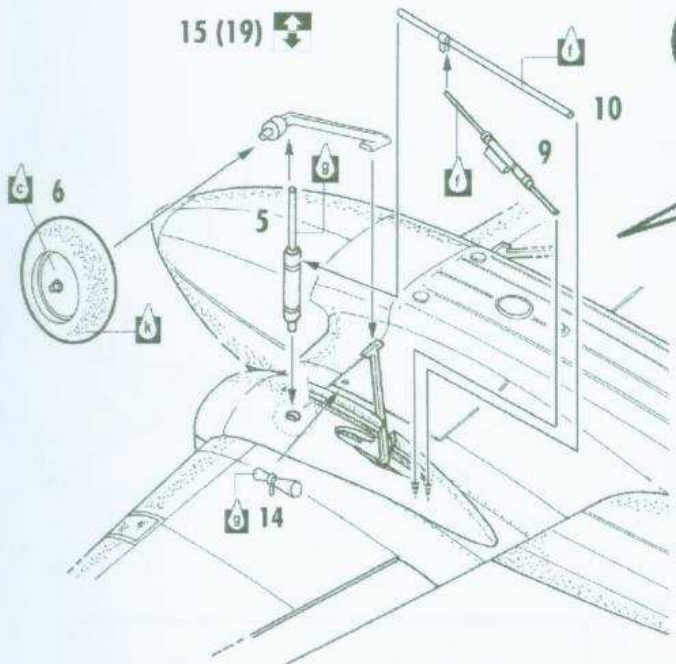

info

STEP 10

(2x)

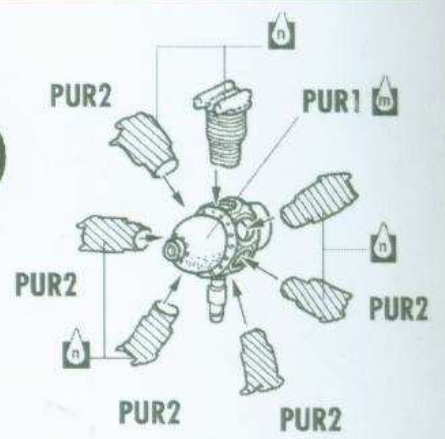

STEP 11

(2x)

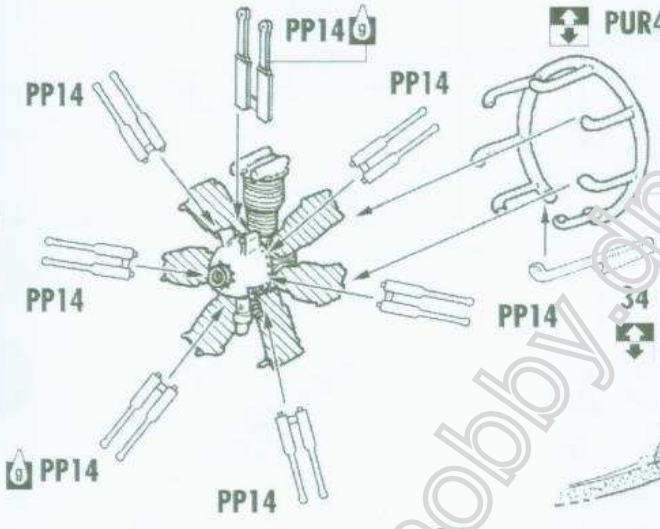

Exhaust on right side
Výfuk napravo

STEP 12

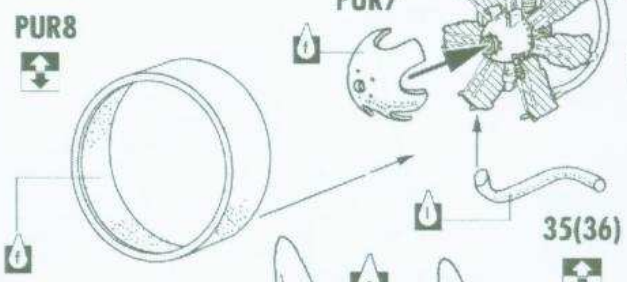

STEP 13

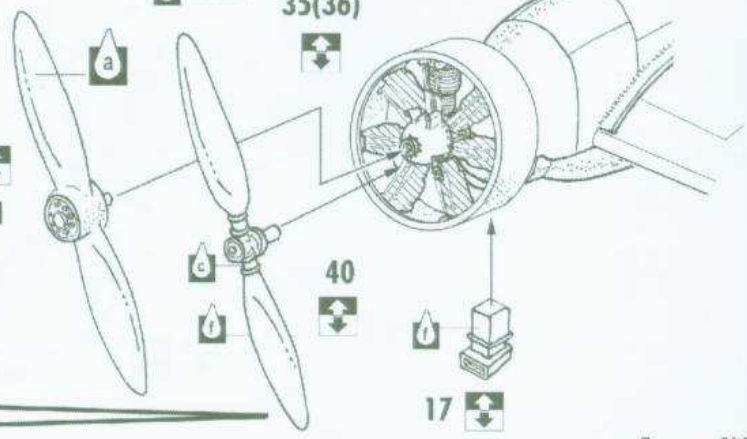

? ONLY CAMOUFLAGE CROATIAN AF

Envoy - CASTOR engine 92098