

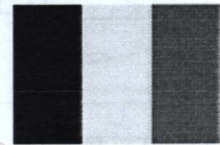

LIMITED EDITION

SOVA-M  
SVM-72013

IAR-80A



UNASSEMBLED PLASTIC MODEL KITS SCALE:1/72

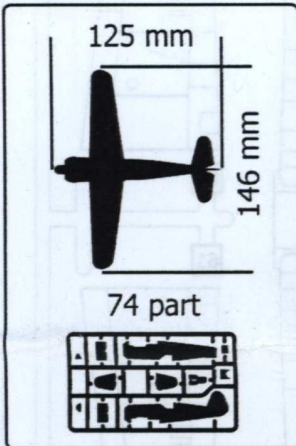

DECALS

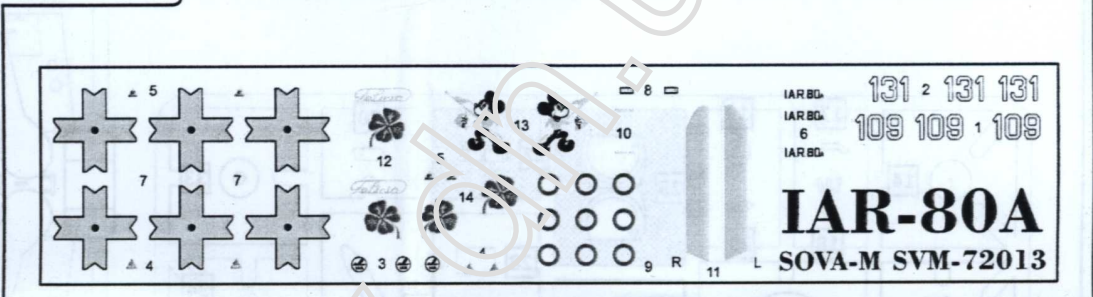

TWO VERSIONS OF COLOURING

The IAR-80 fighter was developed by Romanian company IAR Brasov. In April 1939, chief pilot Dumitru Popescu lifted the aircraft up in the air for a first time. Production flight tests took place at the aerodrome in Brasov. Shown performance turned out to be very good and after a number of developments the IAR-80 was put into serial production. The aircraft came in such modifications as IAR-80/A/B/C, IAR-81/A/B/C, differed mostly in engines and armaments. The IAR-80 and IAR-81 fighters had been actively used on the eastern front line until the summer of 1943. After that all aircrafts were transferred in Romania for the state petroleum complex defense.

The model is executed on technology short run and is intended only for experienced modelers.  
 Word-wide distributor for Sova-M kits:  
 ModelSvit Balkans Ltd. 4003 Plovdiv,  
 Bulgaria 9, zk Maritza Gardens.  
 Tel. +359 32 397 069,  
 E-Mail: modelsvitbalkans@gmail.com  
 MADE IN UKRAINE

PAINTS

- |                                |                                |
|--------------------------------|--------------------------------|
| <b>A</b> HUMBROL 30 DARK GREEN | <b>B</b> HUMBROL 29 DARK EARTH |
| <b>C</b> HUMBROL 65 LIGHT BLUE | <b>D</b> HUMBROL 24 YELLOW     |
| <b>E</b> HUMBROL 33 BLACK      | <b>F</b> HUMBROL 113 RUST      |
| <b>G</b> HUMBROL 64 LIGHT GREY | <b>H</b> HUMBROL 25 BLUE       |
| <b>K</b> HUMBROL 19 RED        | <b>L</b> HUMBROL 62 LEATHER    |
| <b>M</b> HUMBROL 53 GUN METAL  |                                |

SYMBOLS

- |                                  |          |            |               |           |
|----------------------------------|----------|------------|---------------|-----------|
| <b>1</b> STAGES OF ASSEMBLY      | TO PAINT |            | TO BEND       |           |
| <b>1</b> NUMBER PARTS            | GLUE     |            | SCRATCH BUILT |           |
| APPLY DECALS                     |          | DON'T GLUE |               | OPEN HOLE |
| <b>x2</b> QUANTITY OF OPERATIONS | HA ВИБІР | OPTIONAL   |               | CAT OUT   |

# SET OF THE PARTS

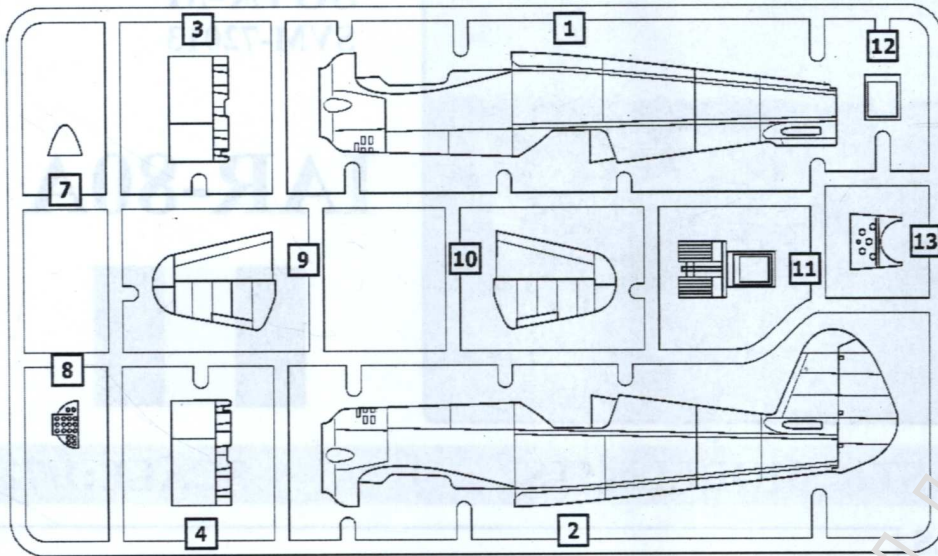

PARTS NOT FOR USE

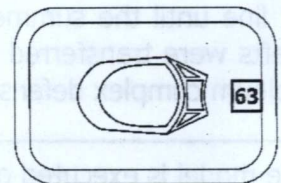
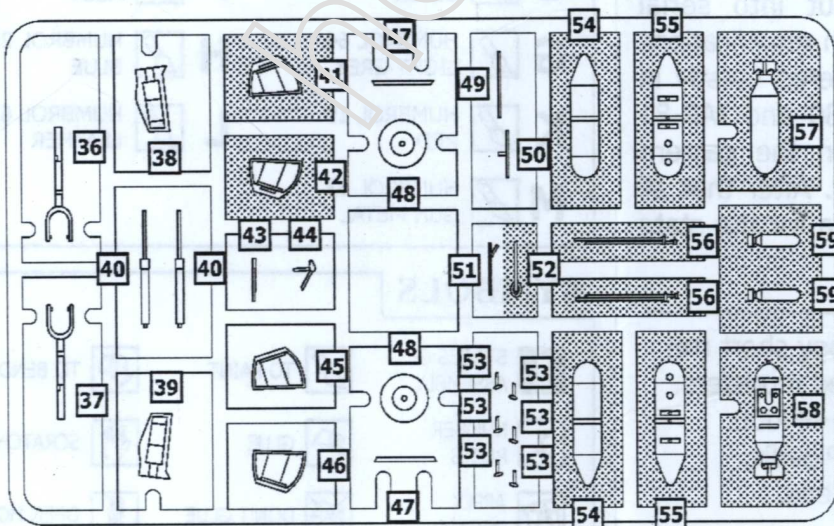
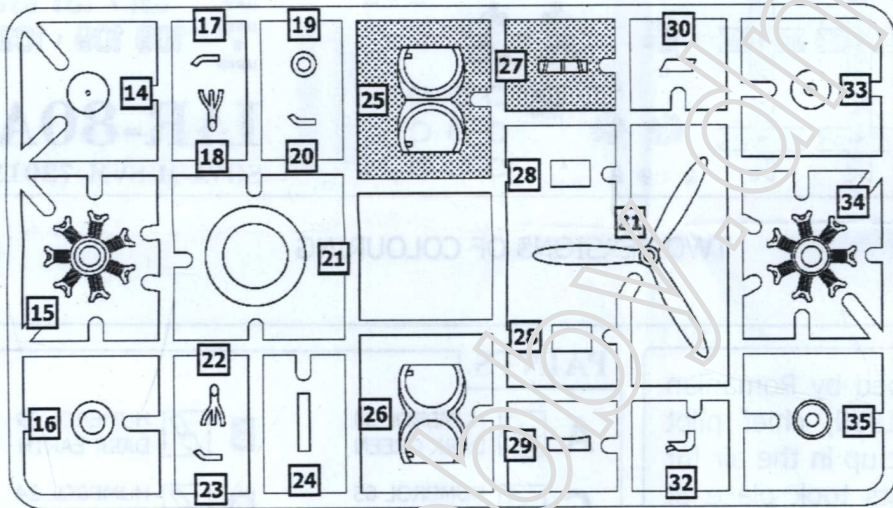
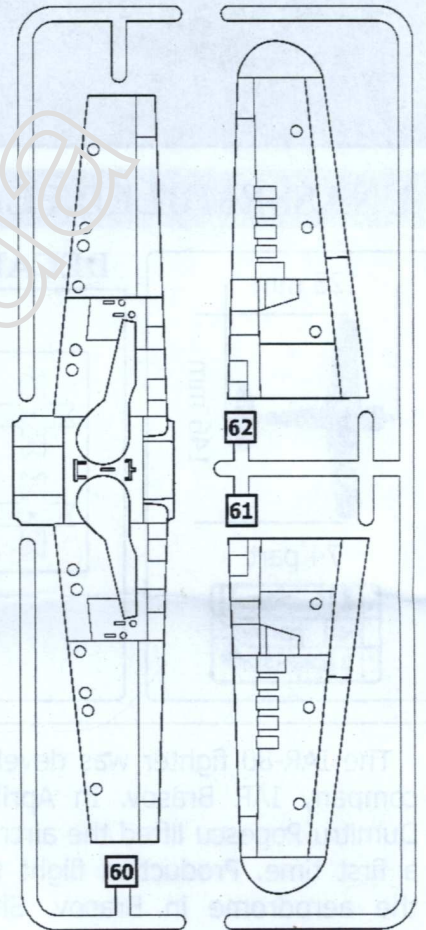

# ASSEMBLY INSTRUCTION

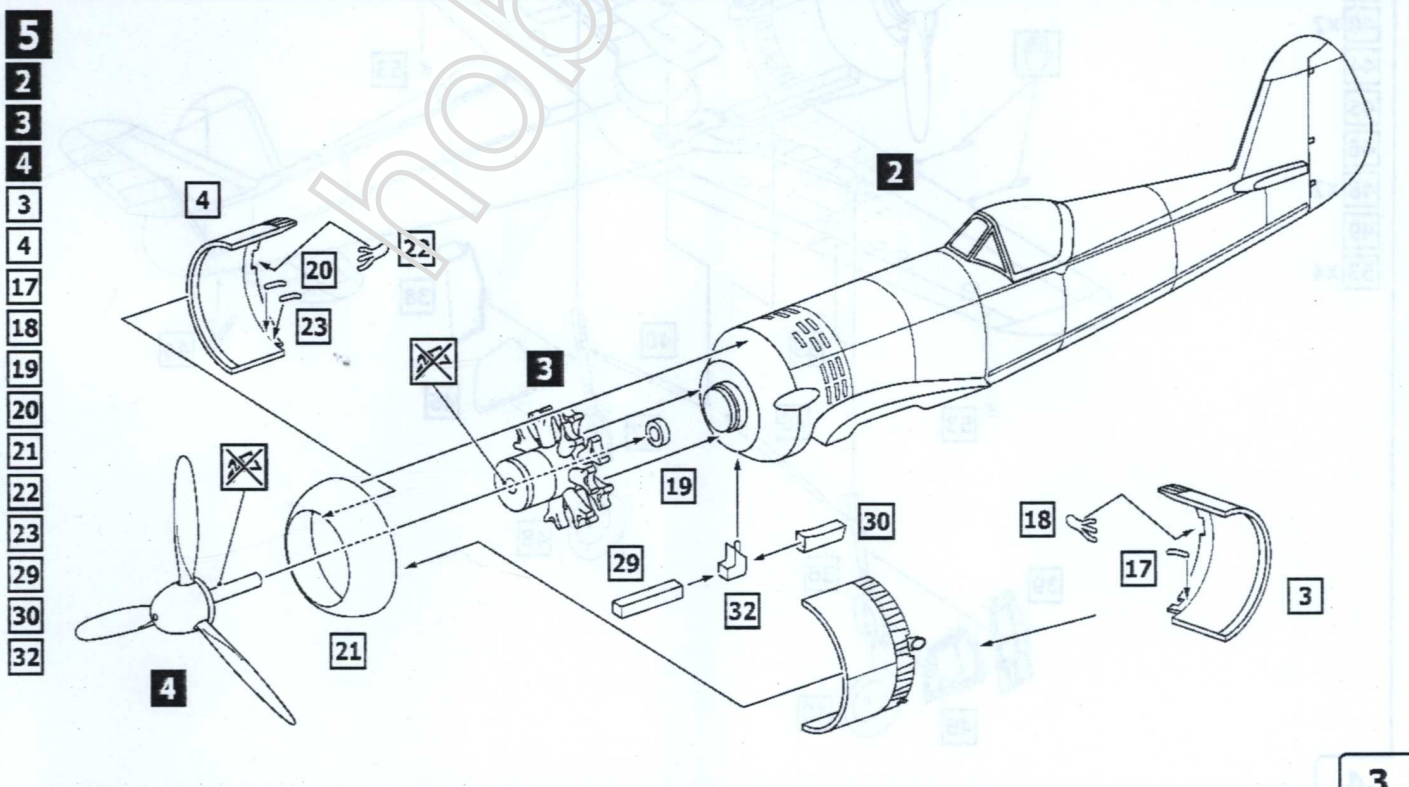
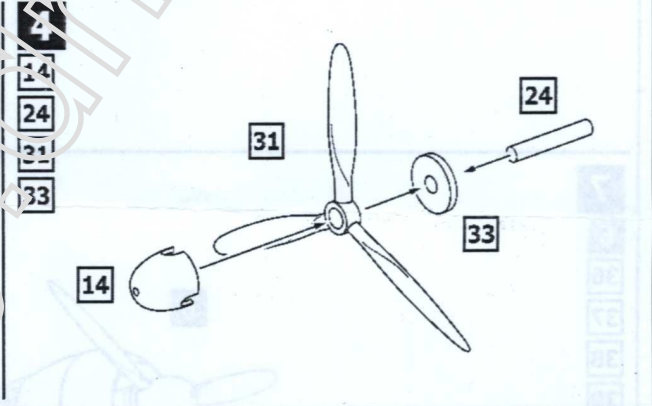
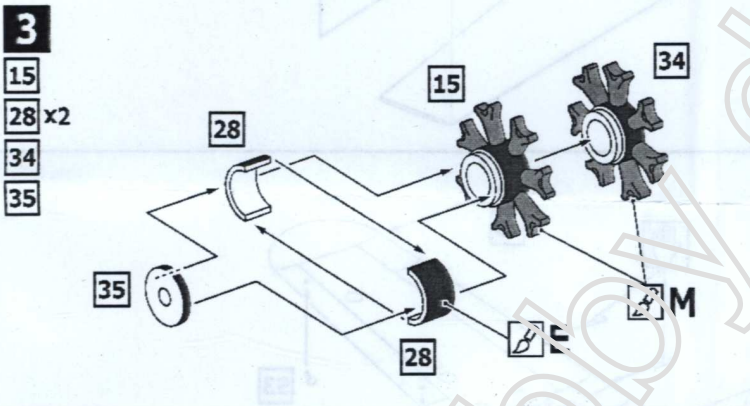
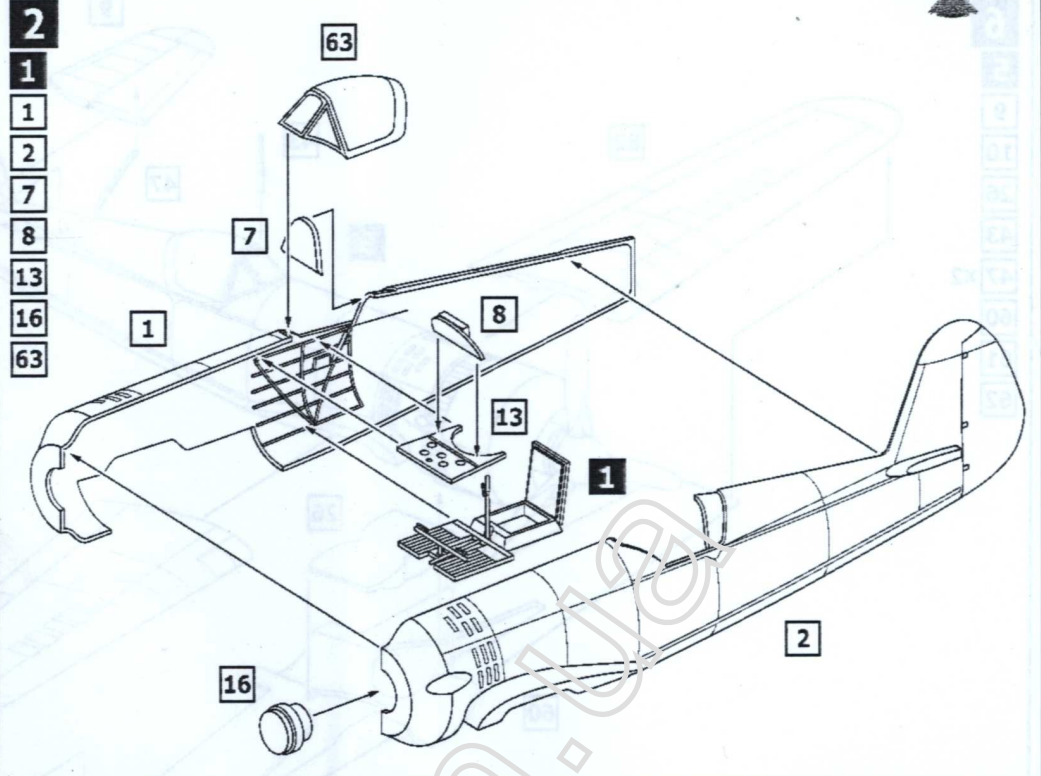
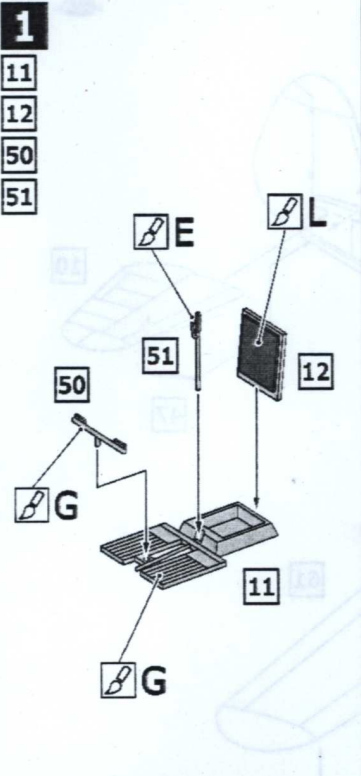

# ASSEMBLY INSTRUCTION



- 6**
- 5**
- 9**
- 10**
- 26**
- 43**
- 47** x2
- 60**
- 61**
- 62**

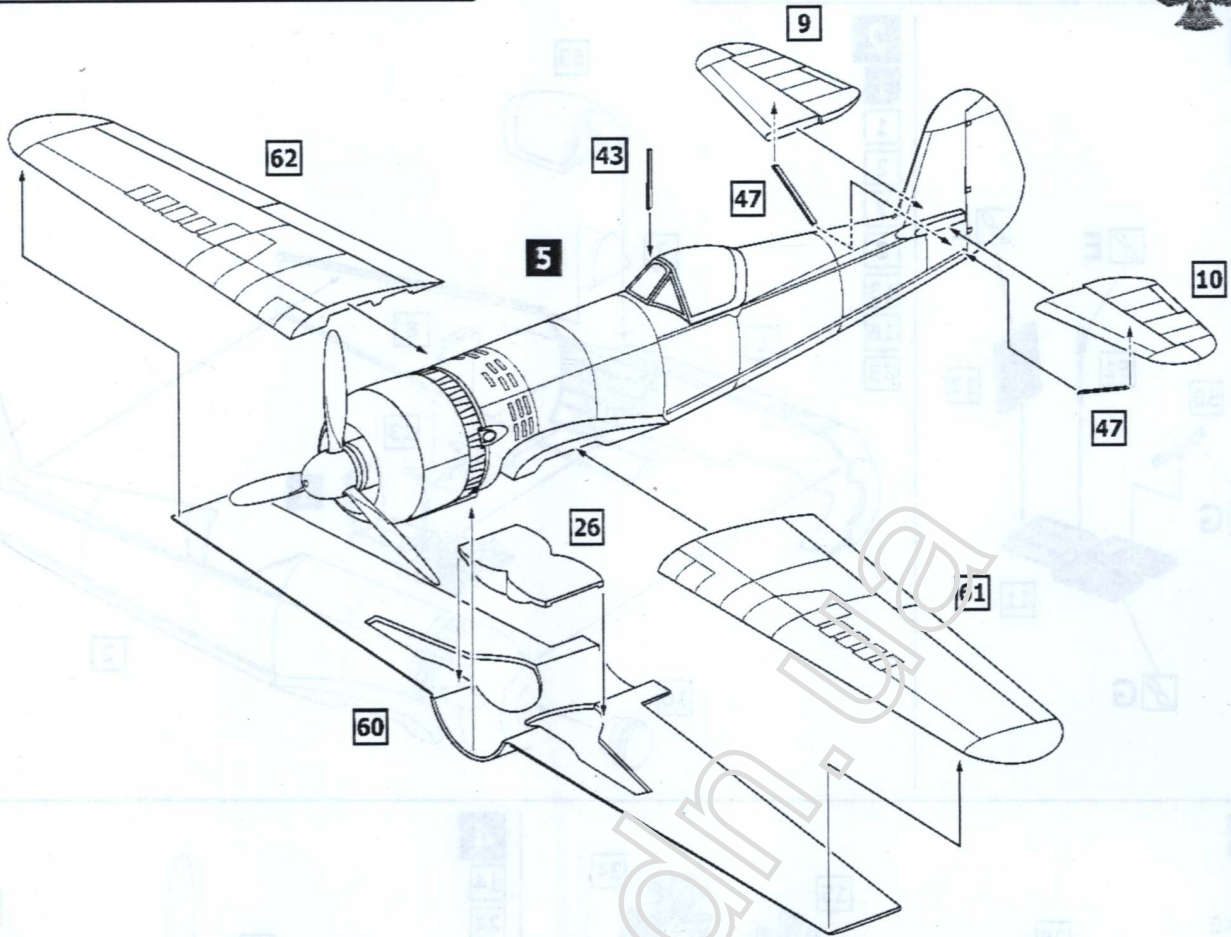

- 7**
- 6**
- 36**
- 37**
- 38**
- 39**
- 40** x2
- 44**
- 45**
- 46**
- 48** x2
- 49**
- 53** x4

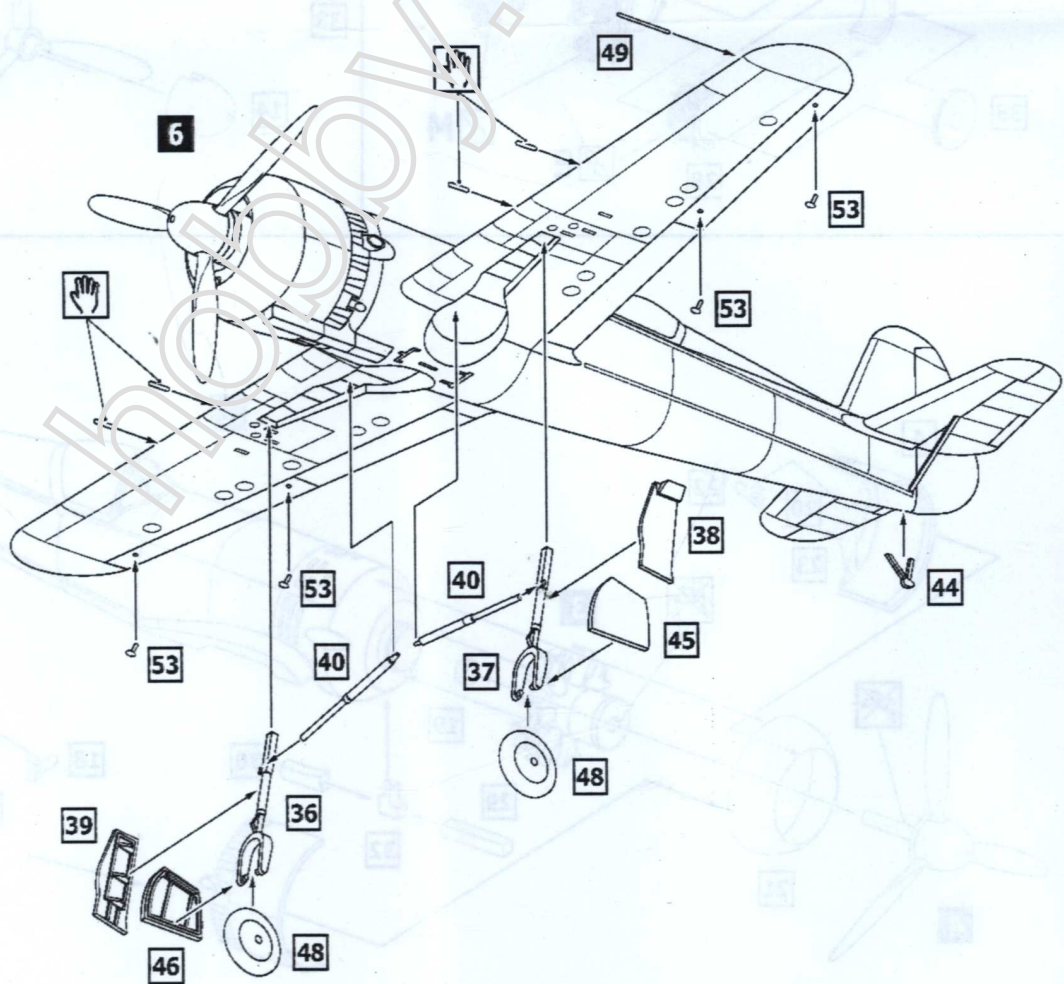

# MARKING & PAINTING

IAR-80A

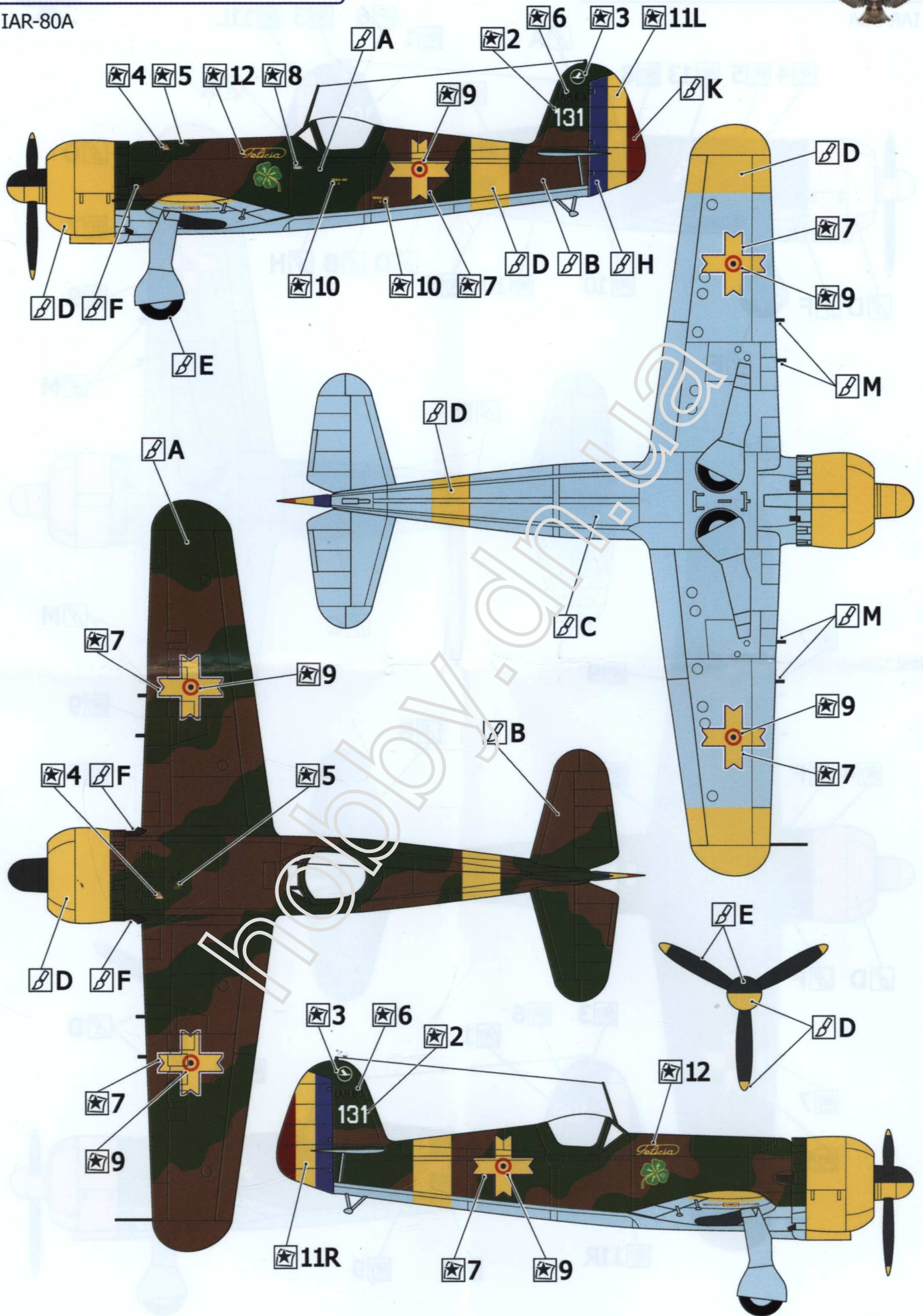

# MARKING & PAINTING

IAR-80A

