



**SOVA-M**  
**SVM-72015**

**Dassault**  
**Falcon 50M**  
**Surmar**



**UNASSEMBLED PLASTIC MODEL KITS**

**SCALE:1/72**

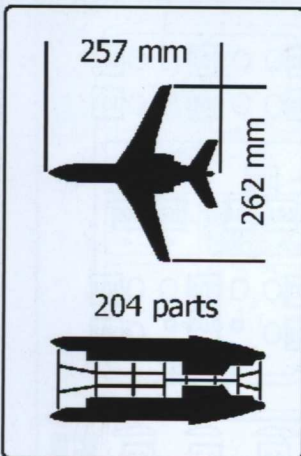

**DECALS**

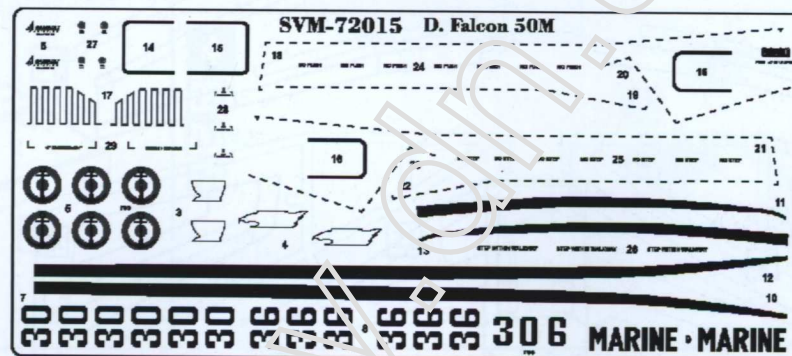

**TWO VERSIONS OF COLOURING**

The Dassault Falcon 50 is a French super mid-sized, long-range business jet, featuring a trijet layout with an S-duct air intake for the central engine. It has the same fuselage cross section and similar capacity as the earlier twin-engine Falcon 20 but is a completely new design that is area ruled and includes a more advanced wing design. The first prototype flew on 7 November 1976, with French airworthiness certification on 27 February 1979, followed by U.S. Federal Aviation Administration certification on 7 March 1979.

**PAINTS**

- |                                 |                                       |
|---------------------------------|---------------------------------------|
| <b>A</b> HUMBROL 130 WHITE      | <b>B</b> HUMBROL 27003 POLISHED STEEL |
| <b>C</b> HUMBROL 33 BLACK       | <b>D</b> HUMBROL 56 ALUMINIUM         |
| <b>E</b> HUMBROL 121 PALE STONE | <b>F</b> HUMBROL 27004 GUN METAL      |
| <b>G</b> HUMBROL 164 DARK GREY  |                                       |

The model is executed on technology short run and is intended only for experienced modelers.  
 Word-wide distributor for Sova-M kits:  
 ModelSvit Balkans Ltd. 4003 Plovdiv,  
 Bulgaria 9, zK Maritza Gardens.  
 Tel. +359 32 397 069,  
 E-Mail: modelsvitbalkans@gmail.com  
**MADE IN UKRAINE**

**SYMBOLS**

- |                                  |                   |               |
|----------------------------------|-------------------|---------------|
| <b>1</b> STAGES OF ASSEMBLY      | TO PAINT          | TO BEND       |
| <b>1</b> NUMBER PARTS            | GLUE              | SCRATCH BUILT |
| APPLY DECALS                     | DON'T GLUE        | OPEN HOLE     |
| <b>x2</b> QUANTITY OF OPERATIONS | НА ВИБІР OPTIONAL | CAT OUT       |

# SET OF THE PARTS



 PARTS NOT FOR USE

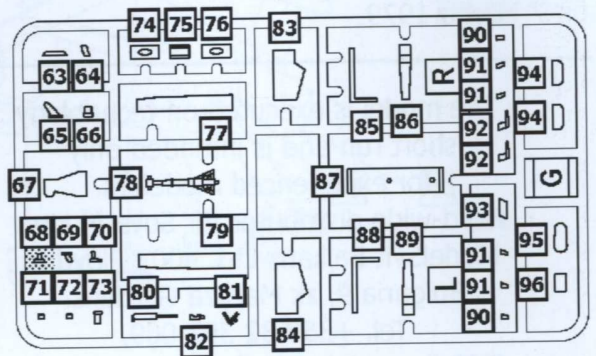
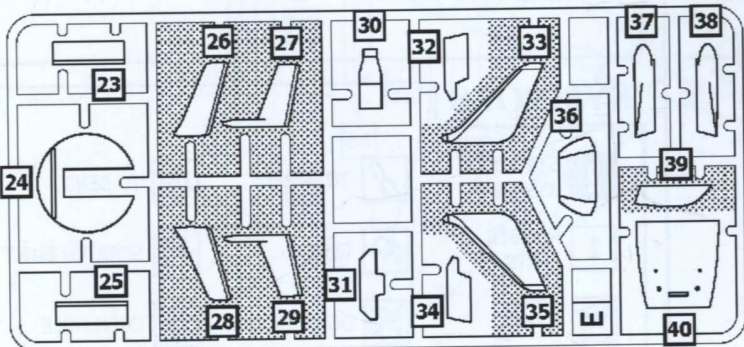
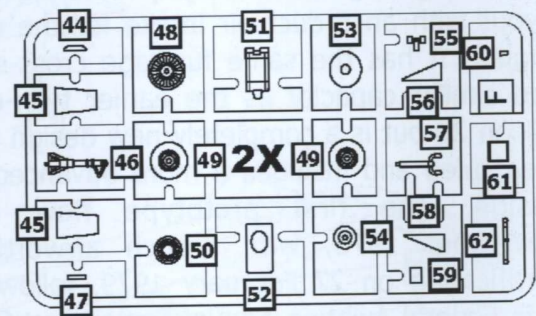
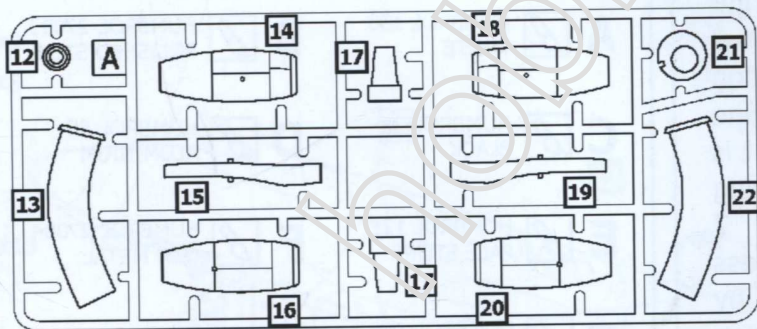
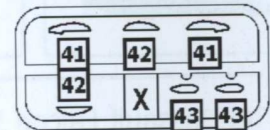
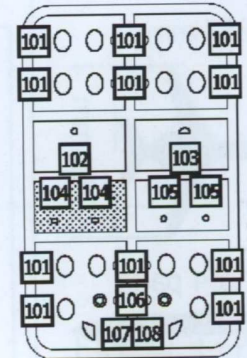
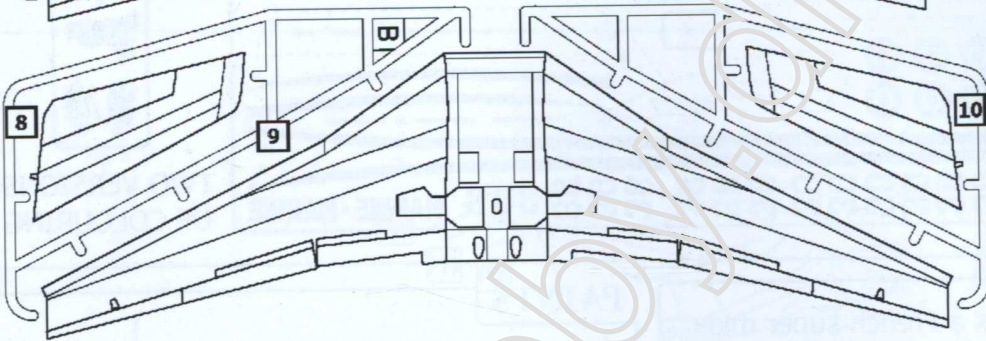
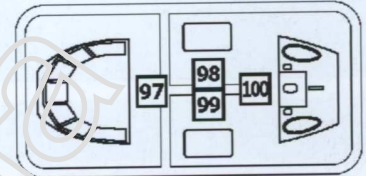
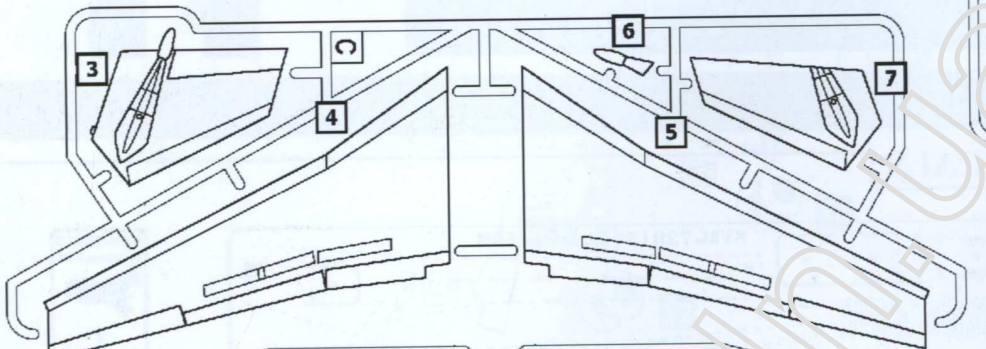
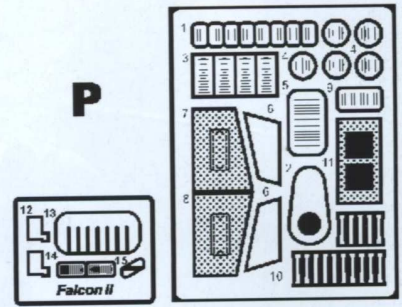
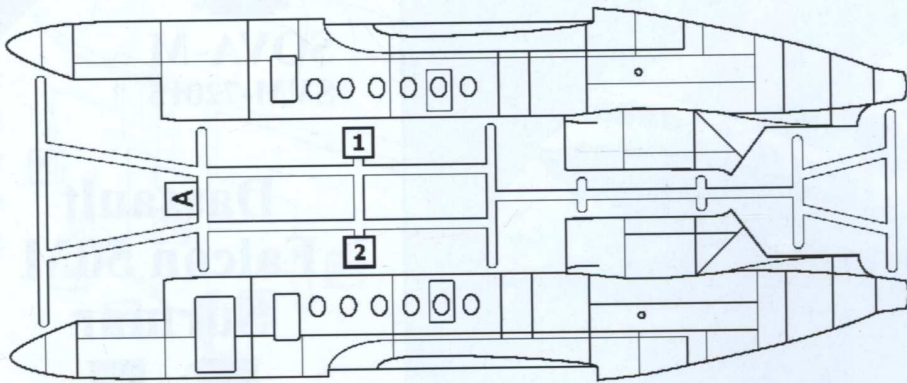

# ASSEMBLY INSTRUCTION



**1** x2

**44** x2

**47** x2

**51** x2

**61** x2

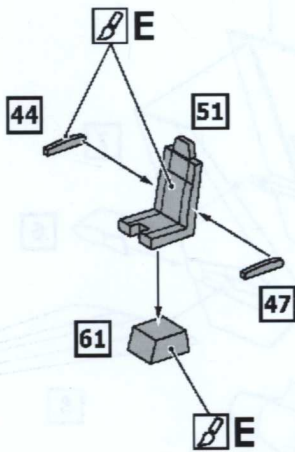

**2**

**1** x2

**23**

**24**

**25**

**30**

**40**

**55** x2

**57** x2

**66**

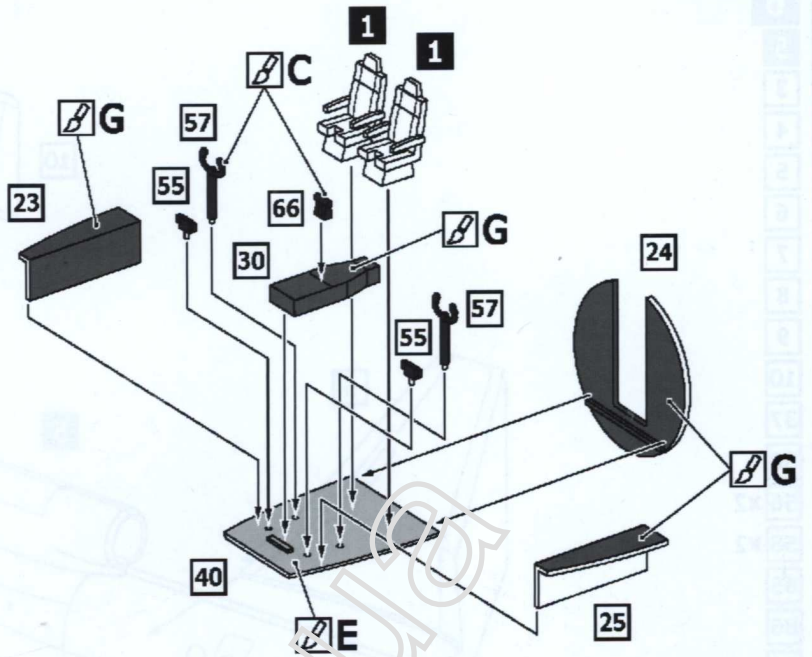

**3**

**77**

**79**

**87**

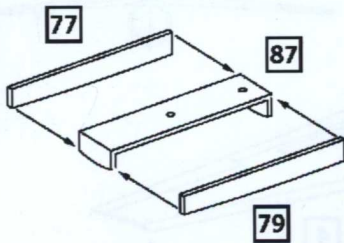

**4**

**12**

**17** x2

**21**

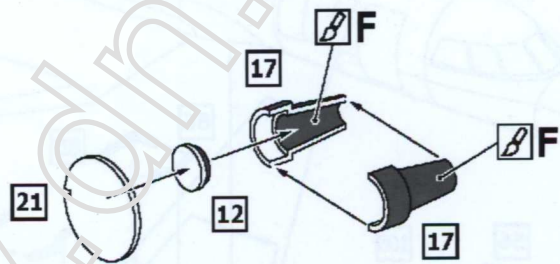

**5**

**2**

**3**

**4**

**1**

**2**

**13**

**22**

**31**

**36**

**97**

**98**

**99**

**101** x12

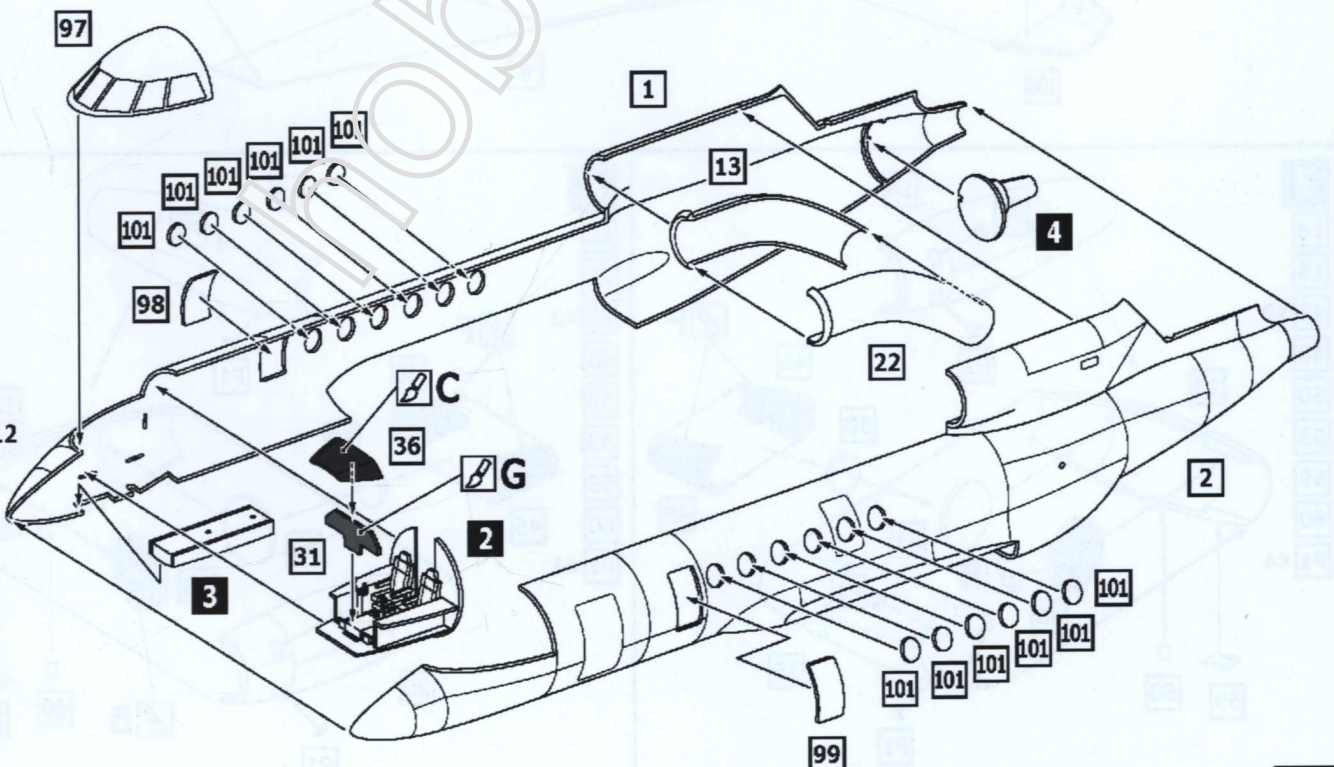

# ASSEMBLY INSTRUCTION



- 6**
- 5**
- 3**
- 4**
- 5**
- 6**
- 7**
- 8**
- 9**
- 10**
- 37**
- 38**
- 56** x2
- 58** x2
- 85**
- 86**
- 88**
- 89**
- 100**
- 106** x2

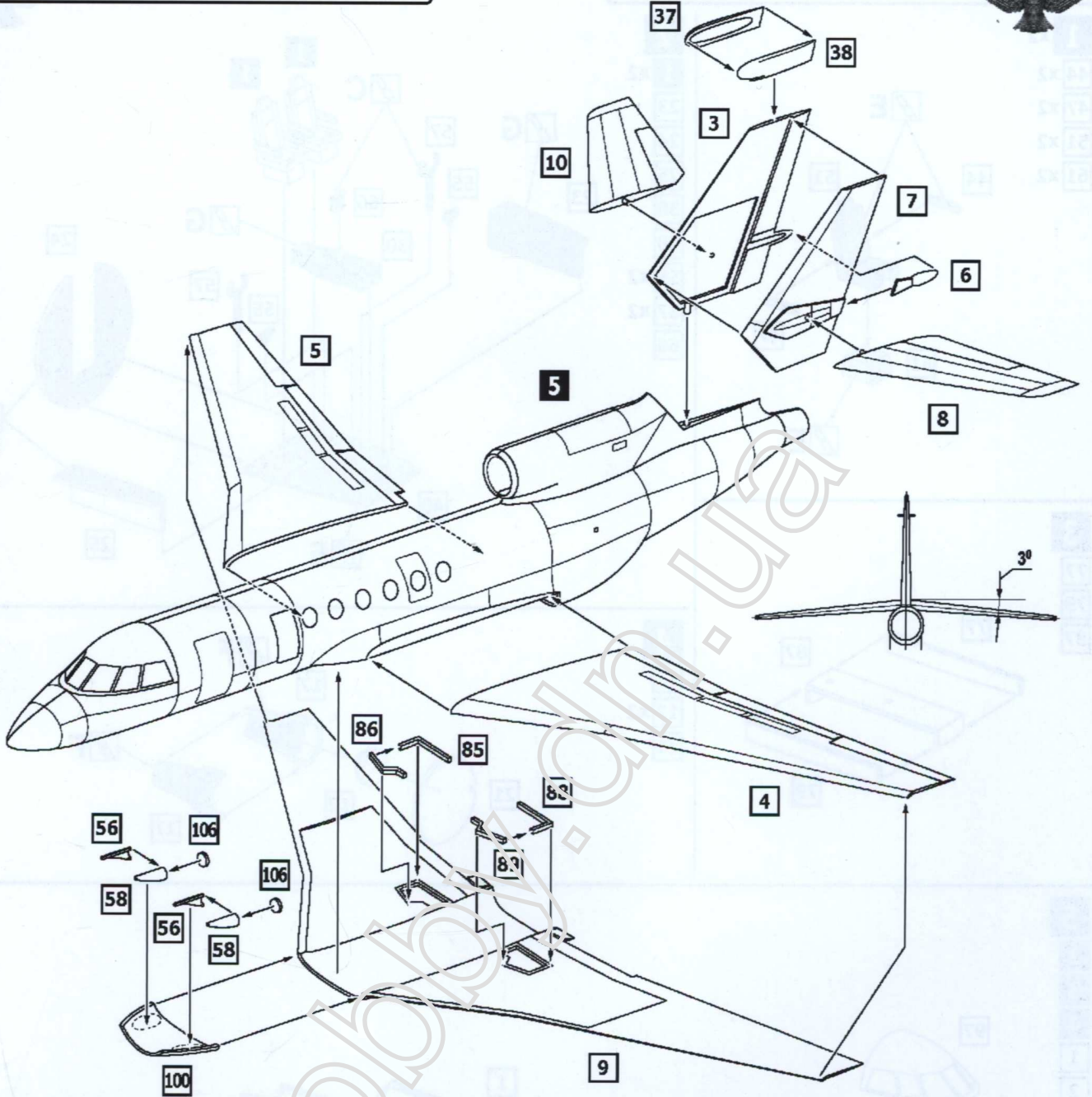

- 7**
- 14**
- 16**
- 45** x2
- 48**
- 50**
- 53**
- 59**
- 60**
- P1** x4

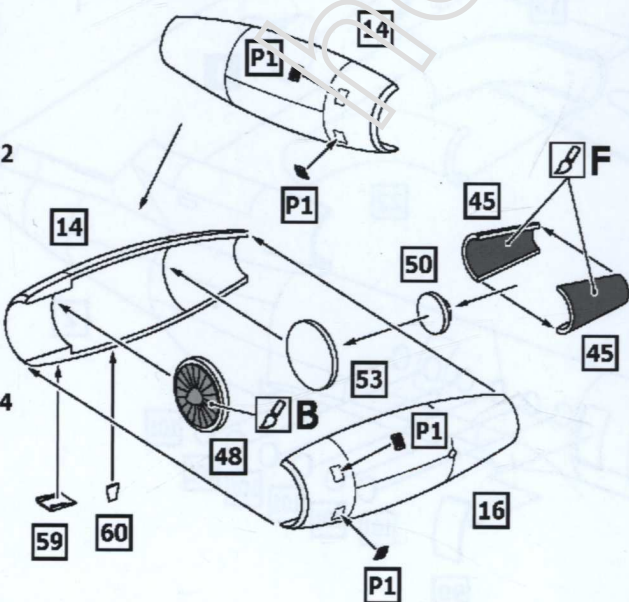

- 8**
- 18**
- 20**
- 45** x2
- 48**
- 50**
- 53**
- 59**
- 60**
- P1** x4

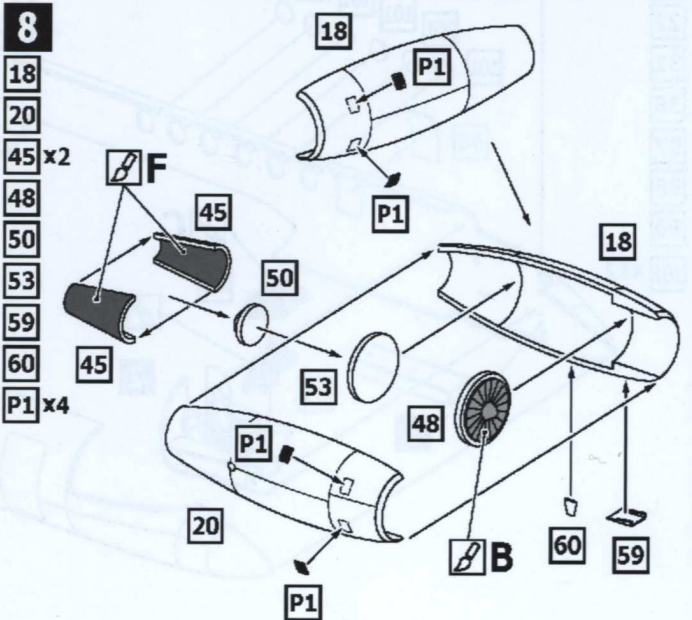

# ASSEMBLY INSTRUCTION



- 9**
- 6**
- 7**
- 8**
- 15**
- 19**
- 32**
- 34**
- 94** x2
- 107**
- 108**

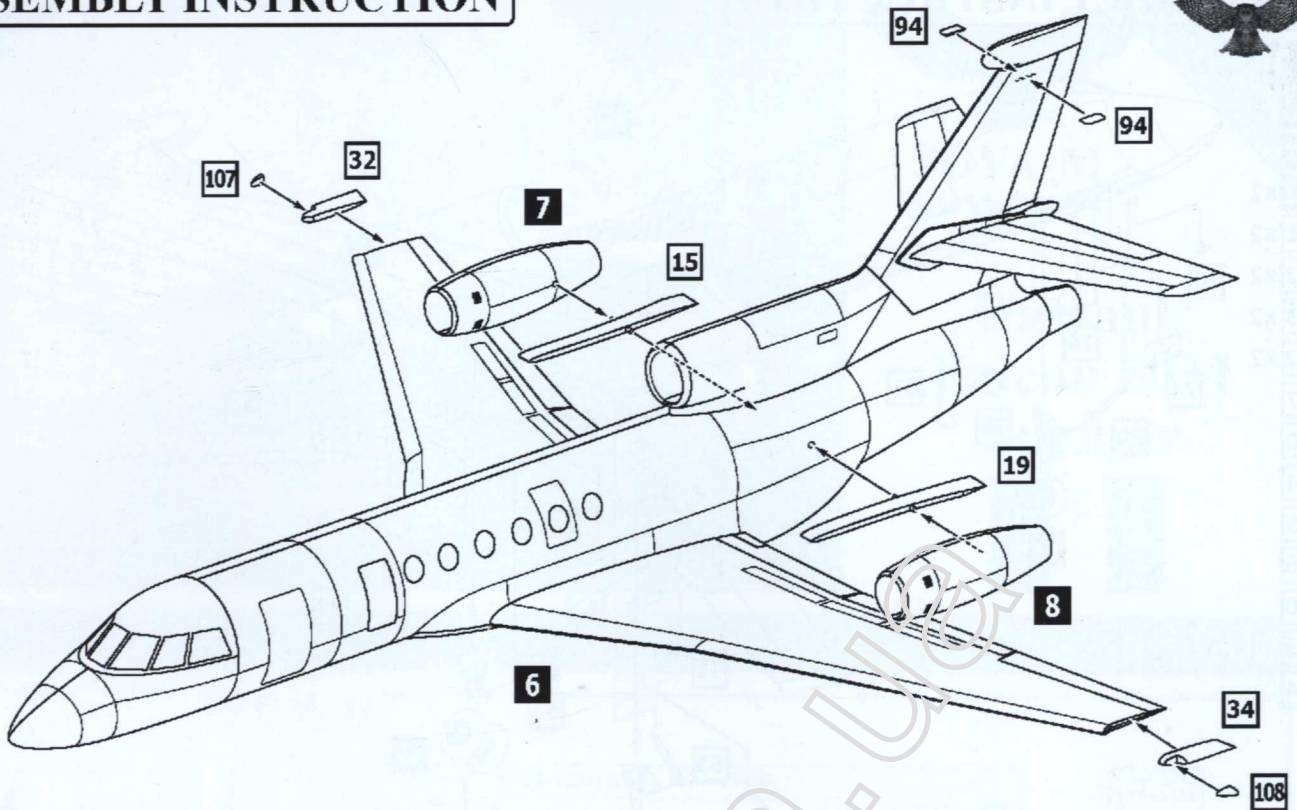

- 10**
- 9**
- 69**
- 71**
- 72**
- 90** x2
- 92** x2
- 95**
- 96**
- 105**
- P2**
- P10** x2
- P12** x2
- P14** x2
- P15** x2

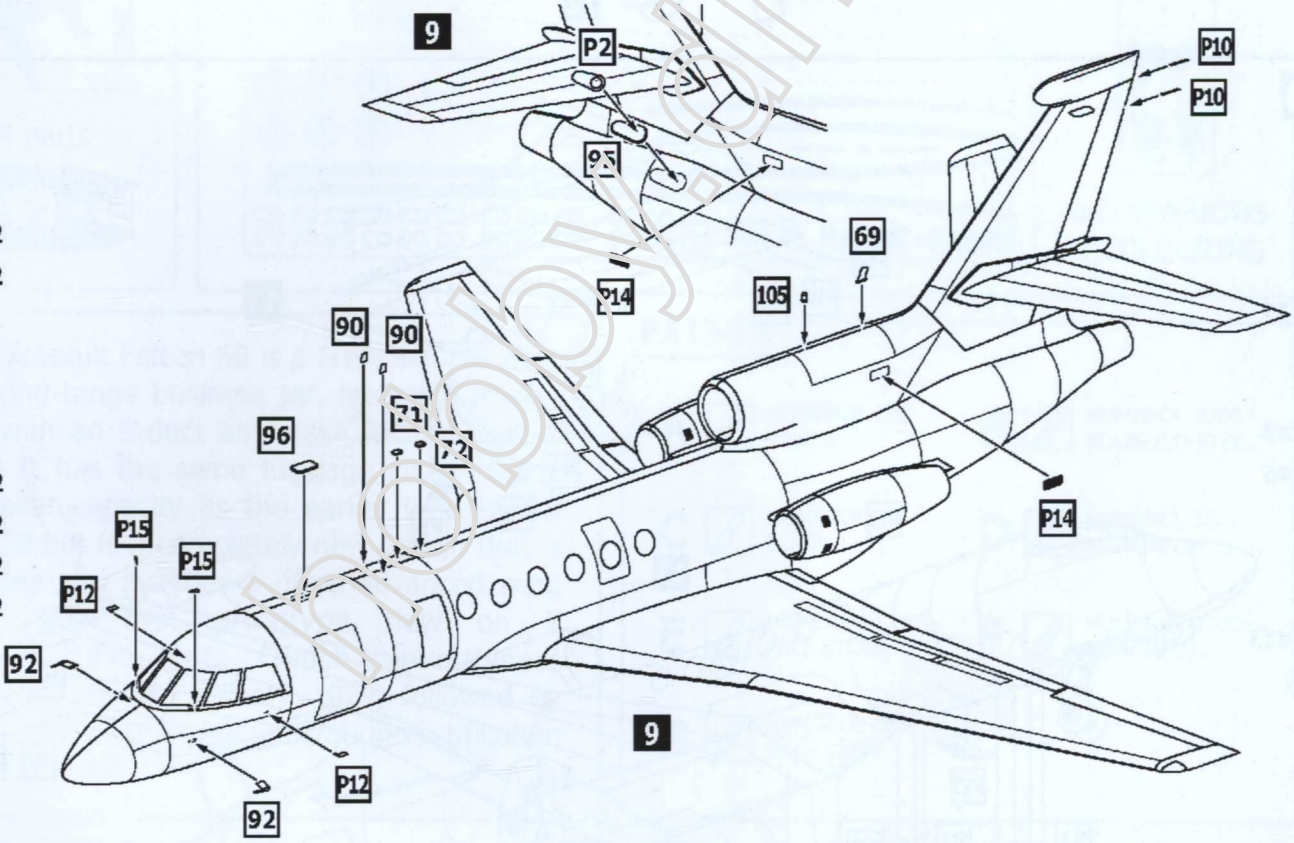

- 11**
- 54** x2
- 78**
- 81**
- 82**
- 102**

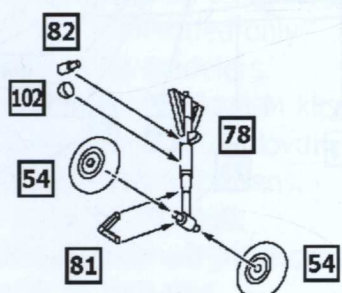

- 12** x2
- 46** x2
- 49** x4

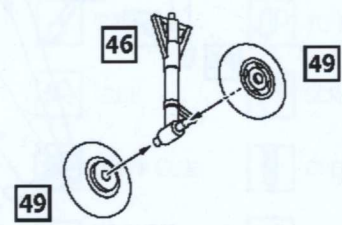



# MARKING & PAINTING

Dassault Falcon 50M Surmar

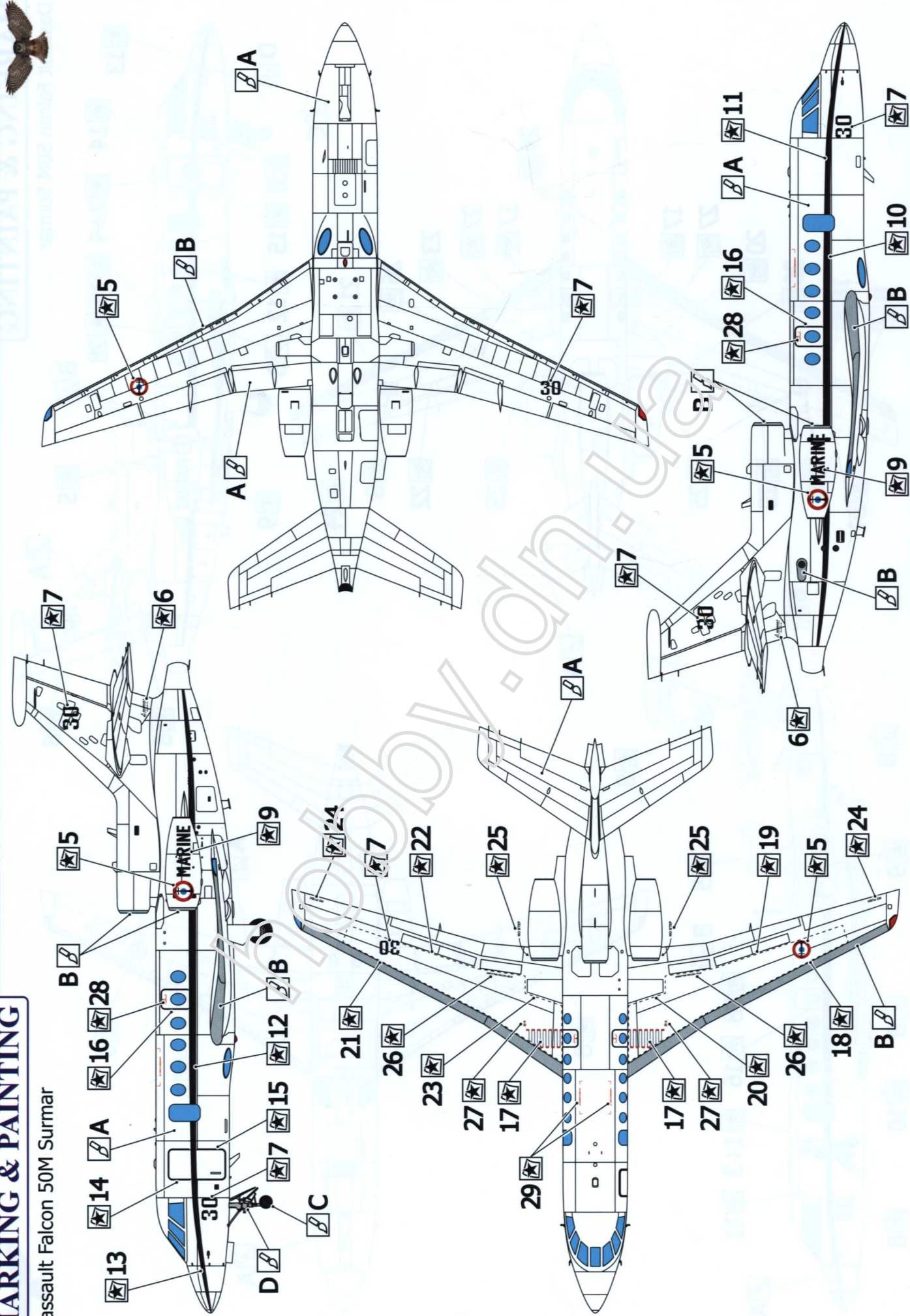

# MARKING & PAINTING

Dassault Falcon 50M Surmar

