



**Reggiane
Re 2000
'1. serie'**

CZ

Italské letectvo před druhou světovou válkou velmi dlouho spoléhalo na stíhací dvouplošníky. Odrážely se v tom italské zkušenosti z občanské války ve Španělsku, kde vynikající obratnost Fiatů CR.32 vyvažovala rychlost dolnoplošných I-16. Ale vývoj v okolních státech ukazoval, že budoucnost patří stíhacím jednoplošníkům. Proto Regia Aeronautica vypsal v roce 1938 soutěž na stíhací dolnoplošník s hvězdicovým motorem.

Šéfkonstruktér firmy Reggiane, R. Longi navázal na své zkušenosti z práce u firmy Seversky a pro tuto soutěž připravil návrh Re 2000. Nový stroj jako by z oka vypadal typu Seversky P-35, včetně pětinosnikového křídla tvořícího integrální nádrž paliva. První prototyp MM408 vzletl poprvé 24. května 1939. V srpnu byl porovnáván se stíhačkami dalších italských firem a s Bf 109E. Údajně obratností překonával i dvouplošný Fiat CR.42 a i dalšími vlastnostmi dominoval. Ale kvůli zranitelnému křídlu s integrálními nádržemi soutěž nevyhrál. Objednány byly další dva prototypy a série 200 ks. Ta byla ale záhy zrušena, i přes to, že výrobce přepracoval křídlo na třínosnikové s klasickými nádržemi.

O Re 2000 projevil zájem zahraniční letectva. Zájem britské RAF zastavilo vypuknutí druhé světové války. Ještě před koncem roku 1939 ale Re 2000 objednalo Maďarsko, podepsána byla i licenční výroba. Sedmdesát kusů bylo vyrobeno v Itálii, dostaly bojové jméno Héja I. Dodávky se protáhly a skončily až s koncem roku 1941. Dalších stovevadesát jedna Re 2000, s motorem Manfred Weiss WM K-14B a kulomety Gebauer ráže 12,7 mm bylo vyrobeno přímo v Maďarsku. Tyto stroje nesly jméno Héja II. V roce 1940 objednalo velké dodávky italských stíhaček Švédsko, včetně šedesáti kusů Re 2000. Opět italská výroba pokulhávala a poslední Re 2000 byly dodány až v červnu 1942. Dvacet strojů z výrobní linky zabavila Regia Aeronautica. Pět strojů bylo dokončeno jako Re 2000 ser. I, další ve verzi Re 2000 GA s prodlouženým doletem. Část strojů byla přestavěna na verzi Catapultabile, katapultovací verzi určenou jako náhrada Ro 43 a Ro 44.

Italské Re 2000 byly nasazeny hlavně nad Sicílií, při doprovodu konvojů. Fočily se i na útocích proti Maltě. Katapultovací stroje byly testovány z katapultů bitevních lodí, ale nakonec operovaly z pozemních základen.

Maďarské stroje byly nasazeny na východní frontě. V průběhu roku 1942 přestávaly Re 2000 stačit na rostoucí počty letadel protivníka a postupně byly staženy k protivzdušné obraně Maďarska a ke cvičným útvarům. Některé kusy údajně přežily válku a sloužily u cvičných útvarů letectva Maďarské lidové republiky až do roku 1959.

Švédské stroje dostaly vojenské označení J-20. Strážily neutralitu jako záchranné stíhací letouny celou válku. Zasahovaly proti narušitelům vzdušného prostoru obou nepřátelských stran. Několik jich bylo v těchto akcích poškozeno nebo ztraceno. Poslední 'válečnou' ztrátou byl Re 2000 sestřelený střelcem německého Do 24 v dubnu 1945, při snaze eskortovat Do 24 do nejbližšího přístavu. Až po konci války v roce 1945 začaly nahrazovat olétané Re 2000 domácí stíhačky FFTV J-22.

Rozpětí: 11 m, délka: 7,99 m, maximální rychlost: 525 km/h, dostup: 10 500 m, dolet: 1400 km (verze Catapultabile), výzbroj: 2x kulomet Breda SAFAT ráže 12,7 mm

EN

Before the outbreak of WW2, the Italian Air Force (Regia Aeronautica) fighter units had been equipped with and relied on biplane machines for quite a long time. Combat experience gained in the Spanish civil war seemed to have confirmed the advantages of such design over modern monoplanes as the excellent manoeuvrability of the Fiat CR.32 more than balanced out the sheer speed of the opposing I-16 fighters. However, the aviation development in neighbouring countries clearly showed that the future would simply belong to monoplane fighters. And thus, in 1938, the Regia Aeronautica issued requirements calling for a low wing, radial engine-equipped fighter design.

Reggiane's chief designer R. Longi, previously employed by Seversky, followed his experience achieved during his stay at the company and proposed a new design called the Re 2000. The machine bore more than a striking resemblance to Seversky's P-35 monoplane, including such features as the five-spar wing with integrated fuel tanks. The first prototype MM408 was taken aloft for the first time on 24 May 1939. In August, it underwent comparative trials with two other Italian fighter designs and a German Bf 109E. Reportedly, it was capable of outmanoeuvring the biplane Fiat CR.42 and its other characteristics were superior too. However, its wing with the integral fuel tanks was clearly prone to fatal combat damage and therefore, the Re 2000 did not succeed in the competition. Nevertheless, the company received an order for two more prototypes and a batch of 200 production machines, which was shortly cancelled even though the wing design had been reworked to incorporate just three spars and standard style of fuel tanks.

Several other air forces showed their interest in the type though. The British RAF for example, but the outbreak of the war made that deal impossible. Hungarian military placed an order for the type in late 1939, and even the licence production was signed. Seventy examples were built in Italy, receiving the name Héja I, deliveries took delay and were finished only at the end of 1941. Further 191 airframes were produced in Hungary, equipped with Manfred Weiss WM K-14B powerplant and armed with 12.7mm Gebauer machine guns. These were named the Héja II.

Large numbers of various Italian fighters were requested by Sweden in 1940, including sixty Re2000s. The production in Italy took delays again and so the last examples of the Re2000s did not arrive until June 1942, with twenty of them being seized by Italians for their own force. Five airframes were finished in the standard of the Re 2000 ser.I, some others as the Re 2000 GA with extended range. A few of the machines were converted to so called Catapultabile variety, capable of being catapult launched from battle ships, and meant to replace the Ro 43 and Ro 44 biplanes.

The Italian Re 2000s were mainly deployed in convoy escort missions around the island of Sicily, they took part in attacks against Malta too. The Catapultabile variety was tested first from battle ship catapults, but in the end, they were used from ground bases.

Hungarian Re 2000s were used on the Eastern front, where in 1942 were found inferior to the still increasing numbers of the opposing fighters and were gradually sent back to Hungary to serve with air defence and training units. Several of them supposedly survived until the end of the war and went on to serve with the new Hungarian People's Republic air force training units as long as until 1959.

Swedish machines were known as the J-20. Being used as interceptors, they guarded Swedish neutrality throughout the long war years. They were scrambled against intruding warplanes of both the Allies and Axis air forces, with some of them being damaged or even lost in these missions. The last one to be lost during the war was a J-20 brought down by a gunner of a German Do 24 flying boat in April 1945, when the Swedish pilot was trying to accompany the plane and escort it to the nearest port. Only when the war had been over in 1945, the remaining, war weary J20s were put off service and replaced by new indigenous built FFTV J-22 fighter planes.

Wingspan: 11 m, length: 7.99 m, max. speed: 525 km/h, ceiling: 10,500 m, range: 1,400 km (Catapultabile), armament: twin 12.7mm Breda SAFAT machine gun

Plastic Parts

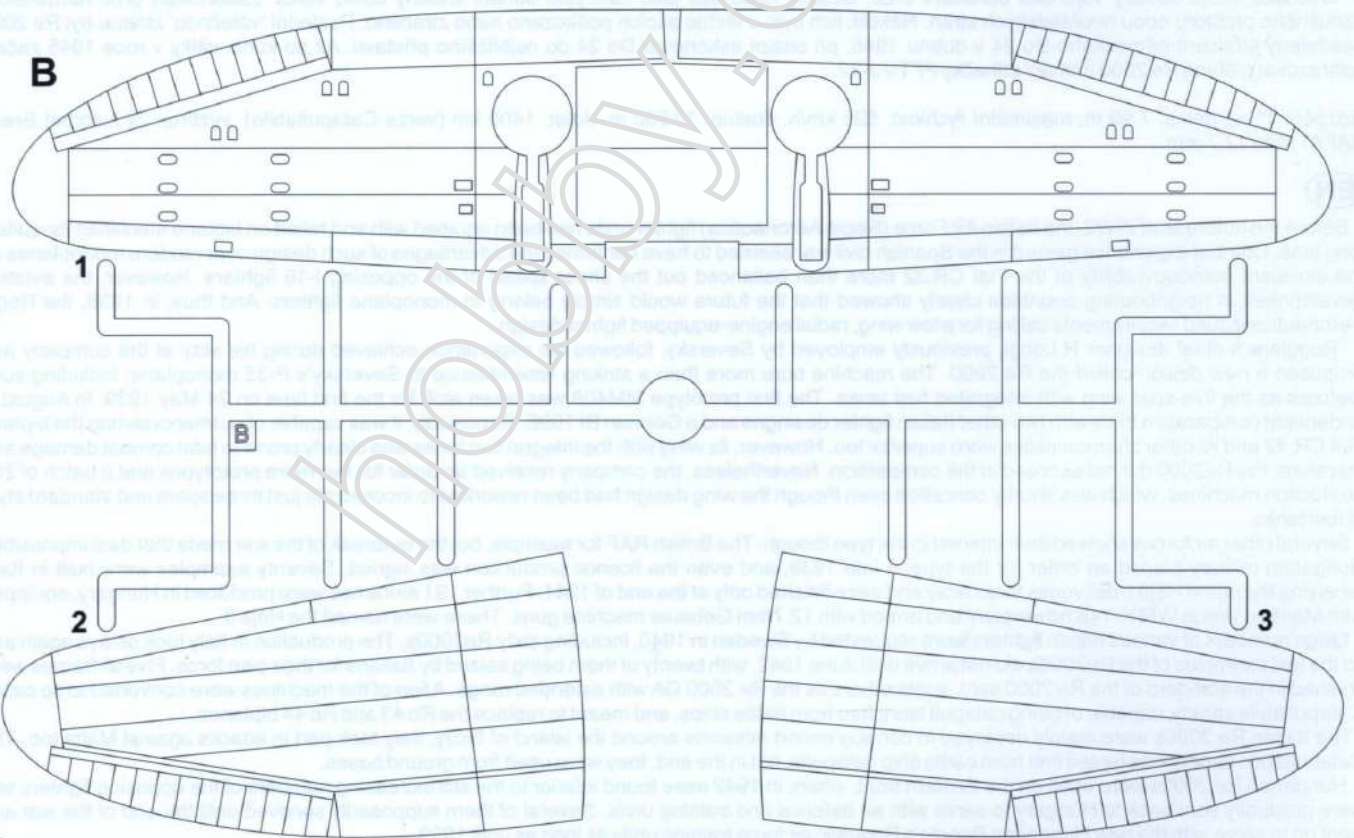
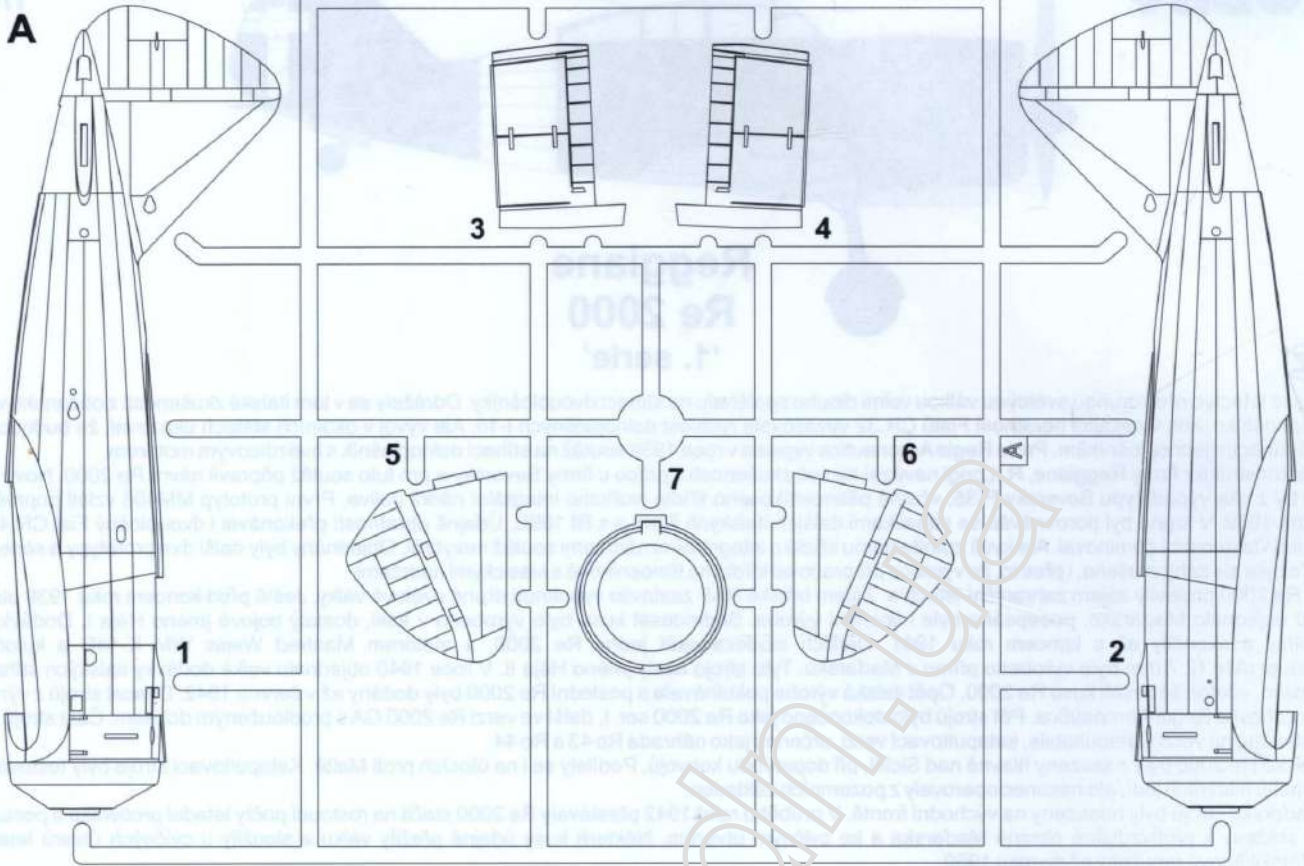

SYMBOLS

- | | | | | | |
|--|---|---|--|---|---|
| <p>MOŽNOST VOLBY
OPTIONAL
NACH BELIEBEN
OPTION</p> | <p>POUŽÍT KYANOAKRYLÁTOVÉ LEPIDLO
INSTANT CYANOACRYLATE GLUE
ZYANOAKRYLÁTKLEBER
COLLE CYANOACRYLATE</p> | <p>OHNOUT
BEND
BIEGEN
COURBER</p> | <p>ZHOTOVIT NOVÉ
SCRATCH BUILD
FERTIGSTELLEN
ACHEVER</p> | <p>ŘEZAT/VRTAT
CUT OFF/DRILL
ENTFERNEN
DETACHER</p> | <p>GSI
colour code
NATRÍT
COLOUR
FARBEN
PEINDRE</p> |
|--|---|---|--|---|---|

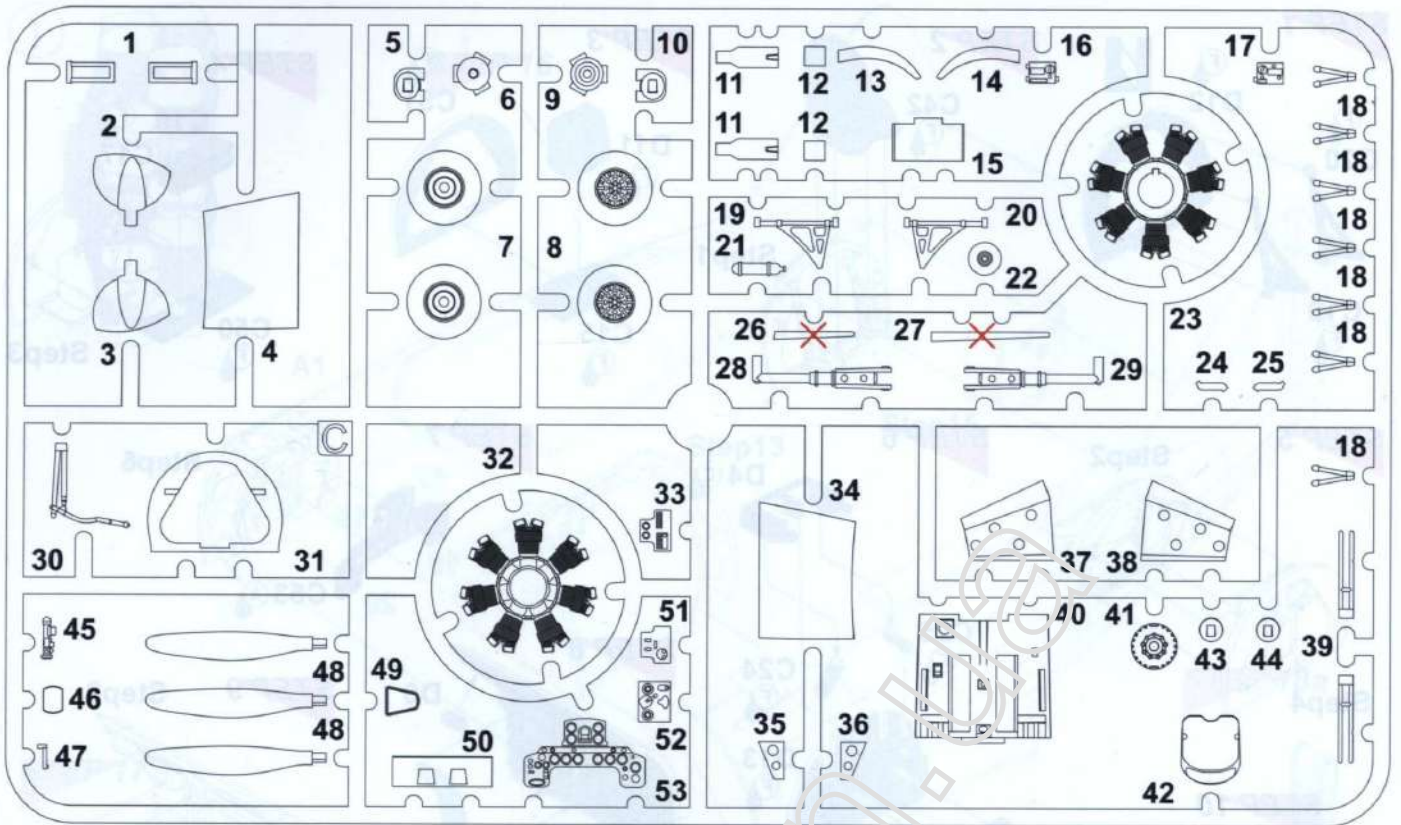

C

D

Clear Parts (CP)

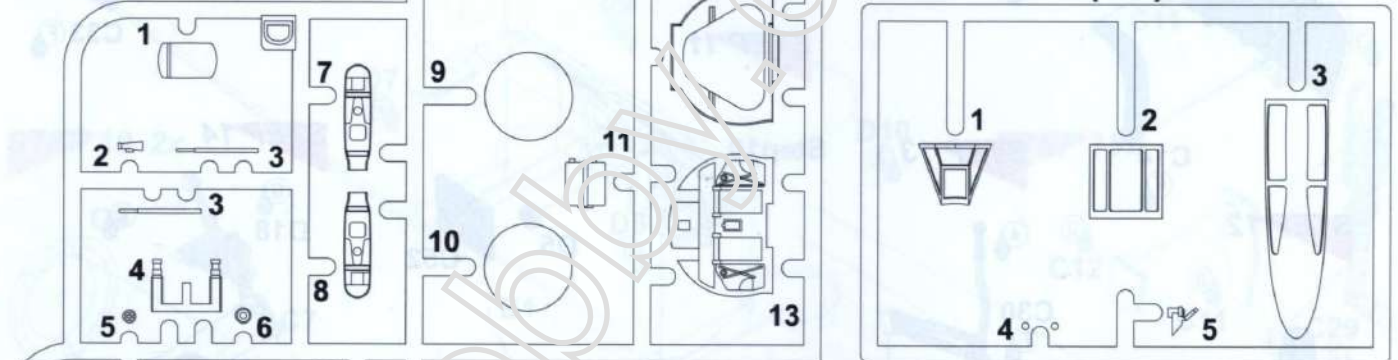

Barvy GUNZE / GUNZE Colour No.

(A) Černá / Black	H12 / C33
(B) Barva pneu / Tire Black	H77 / C137
(C) Tmavý kov / Gun Metal	H28 / C78
(D) Opálený kov / Burnt Iron	H76 / C61
(E) Hliníková / Aluminium	H8 / C8
(F) Antikorozní zelená / Anticorrosive Green / Verde Anticorrosione	H74 / C26
	+10% H1 / C1
(G) Modrošedá / Blue Grey / Grigio Azzurro	H67 / C115
(H) Tmavá zelená / Dark Green / Verde Mimetico Scuro	H303 / C303
(I) Hnědá / Brown / Bruno Chiaro	H74 / C41
(J) Písková / Sand / Giallo Mimetico	90% H79 / C39 +10% H44 / C51
(K) Černá / Black / Nero	H12 / C33
(L) Bílá / White / Bianco	H1 / C1
(M) Jasná zelená / Bright Green / Verde Acceso	H26 / C66
(N) Červená / Red / Rosso	H3 / C3



Tento díl nepoužít
Do not use this part

STEP 1

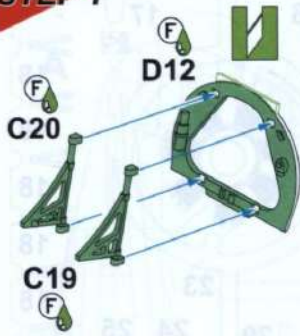

STEP 2

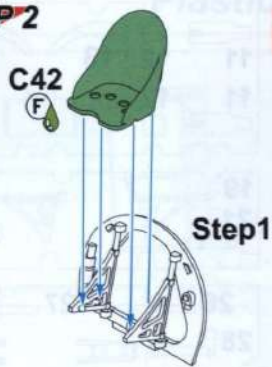

STEP 3

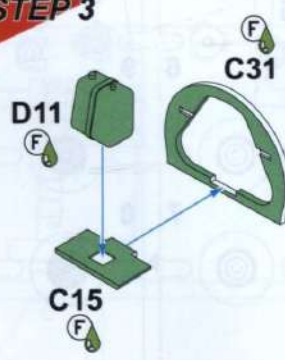

STEP 4



STEP 5

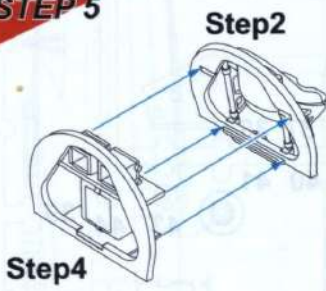

STEP 6

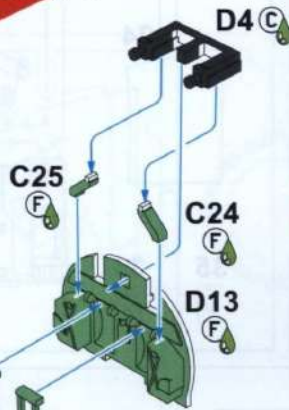

STEP 7

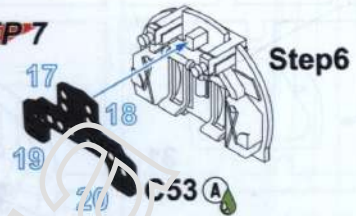

STEP 10

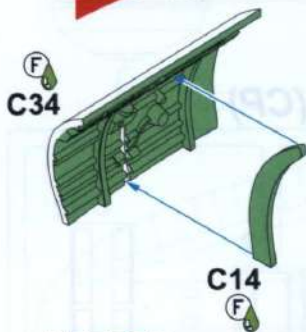

STEP 8



STEP 9

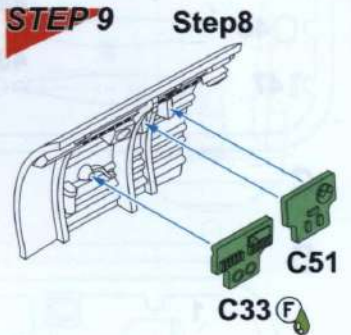

STEP 12

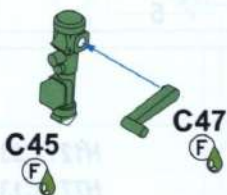

STEP 11

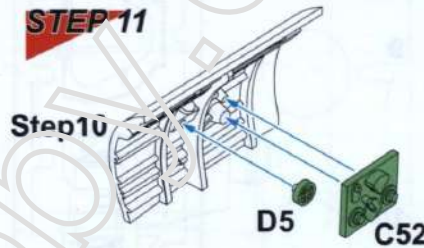

STEP 13

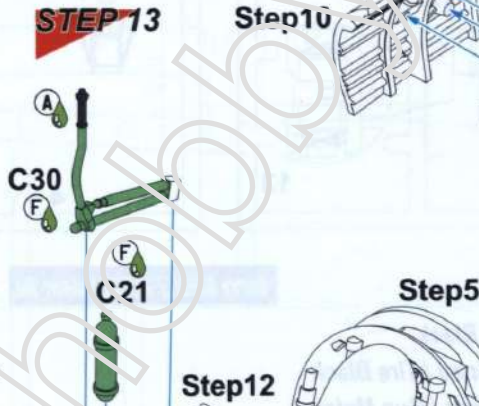

STEP 14

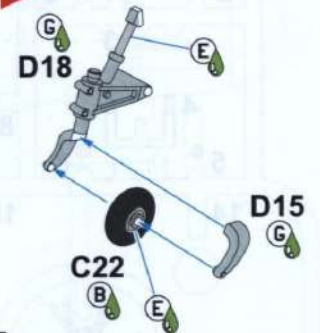

STEP 15

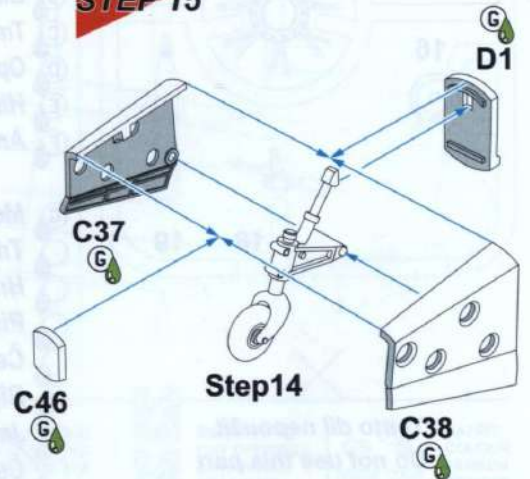

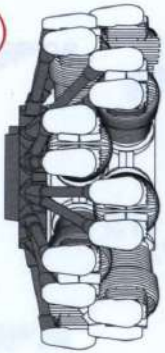

STEP 16

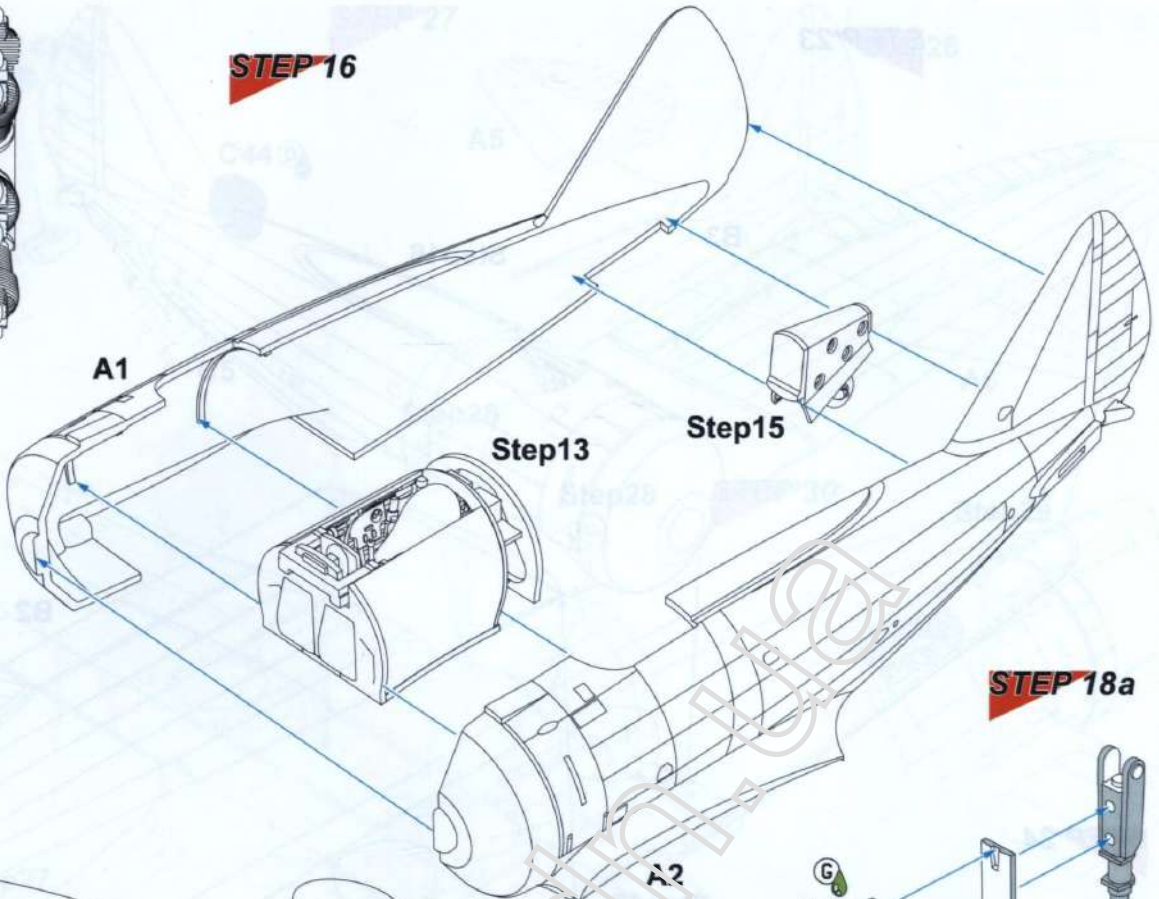

STEP 17

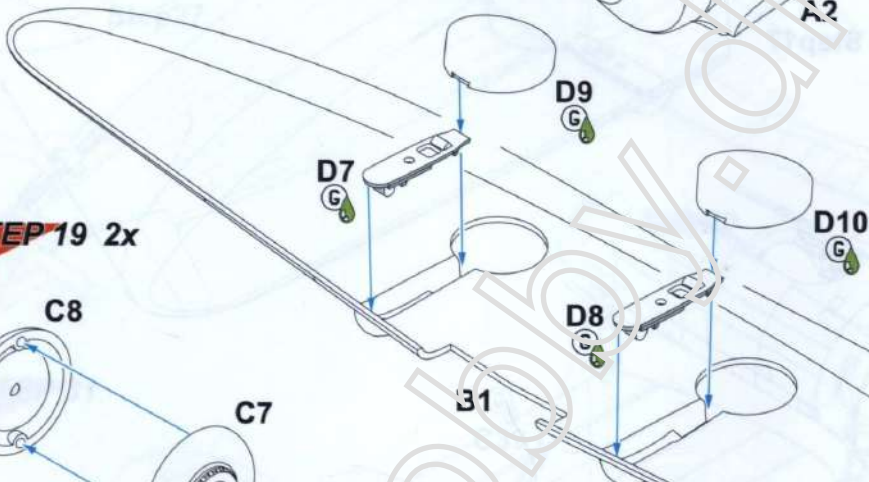

STEP 18a

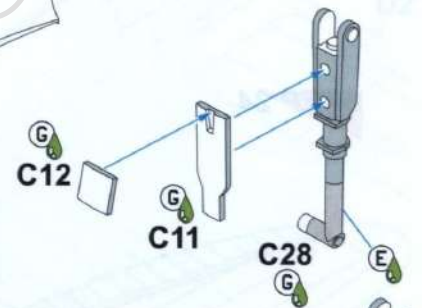

STEP 19 2x

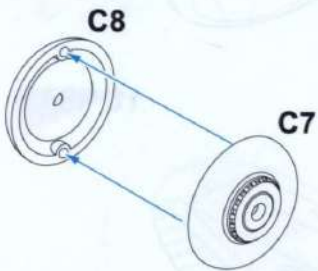

STEP 18b

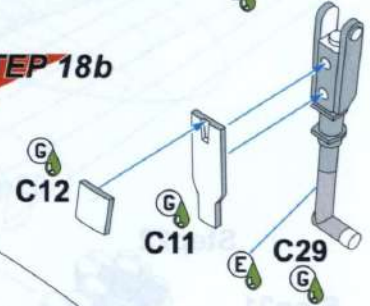

STEP 20



STEP 21

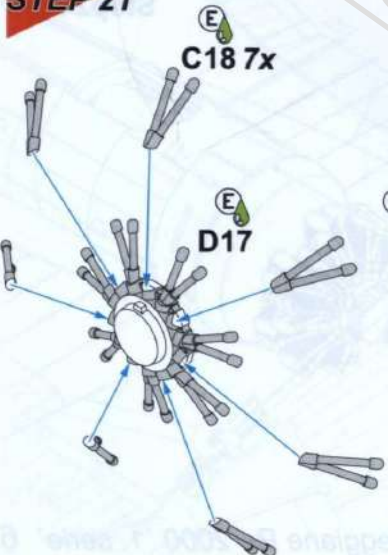

STEP 22

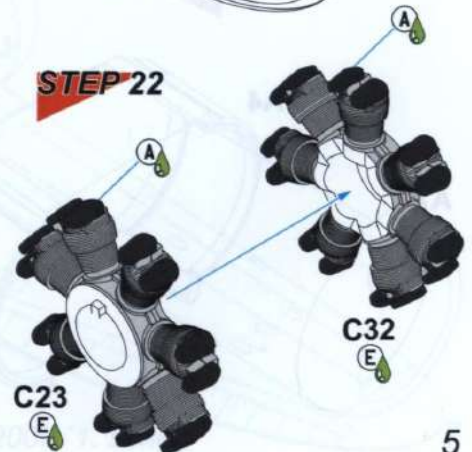

STEP 23

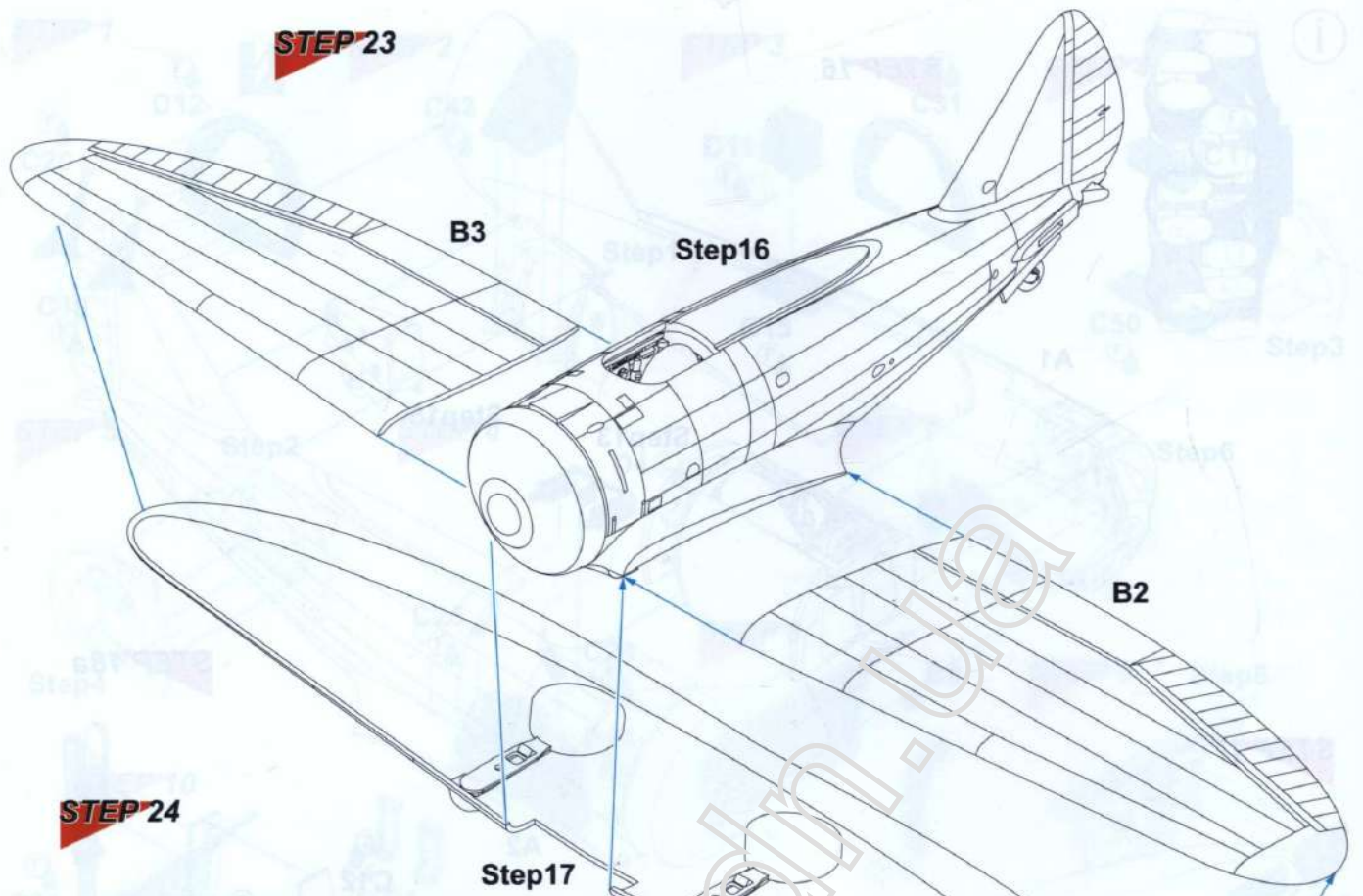

STEP 24

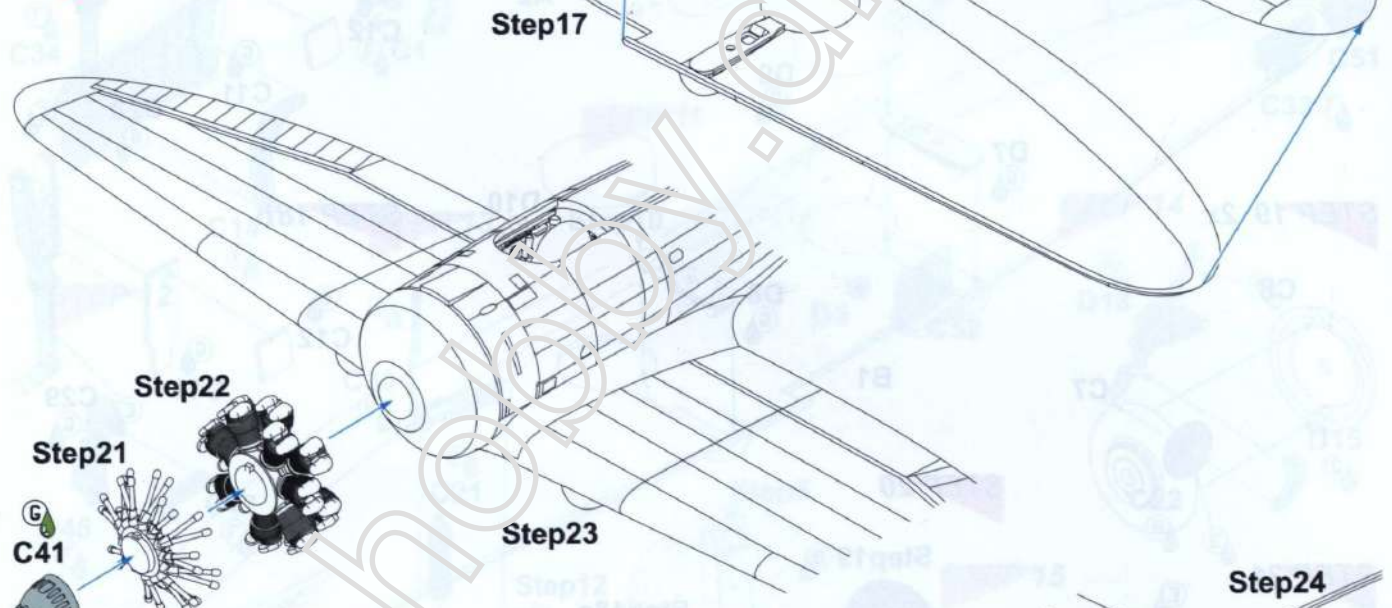

STEP 25

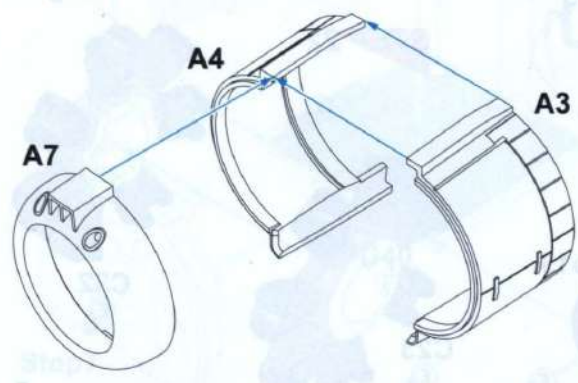

STEP 26

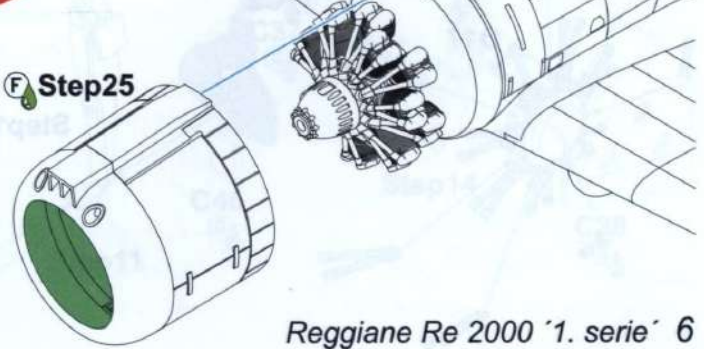

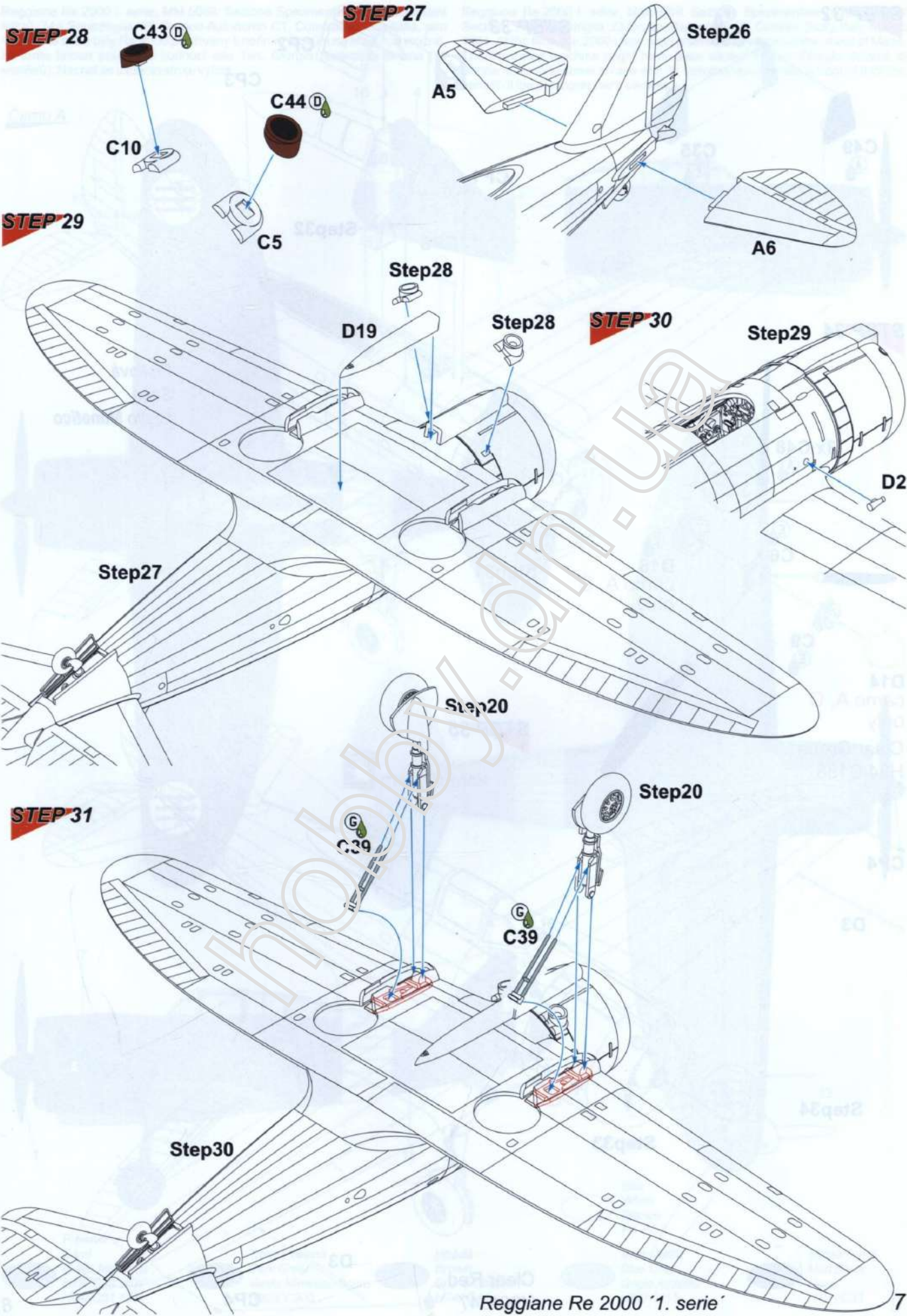

STEP 32

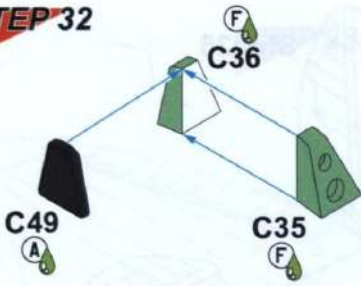

STEP 33

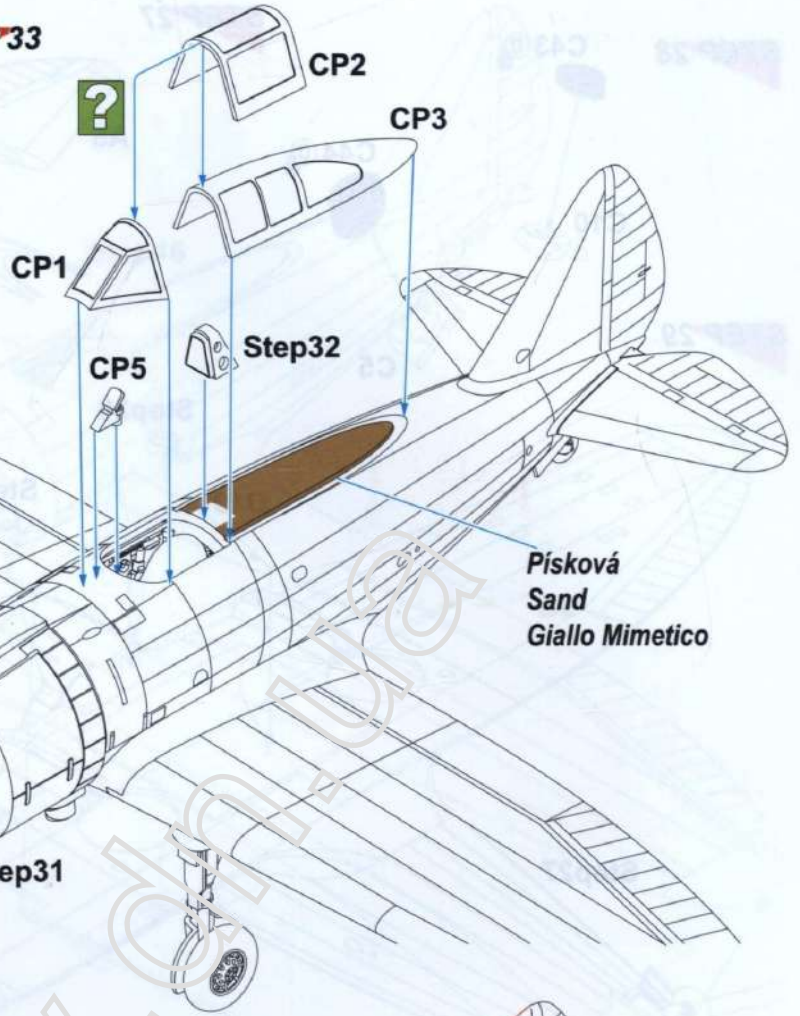

STEP 34

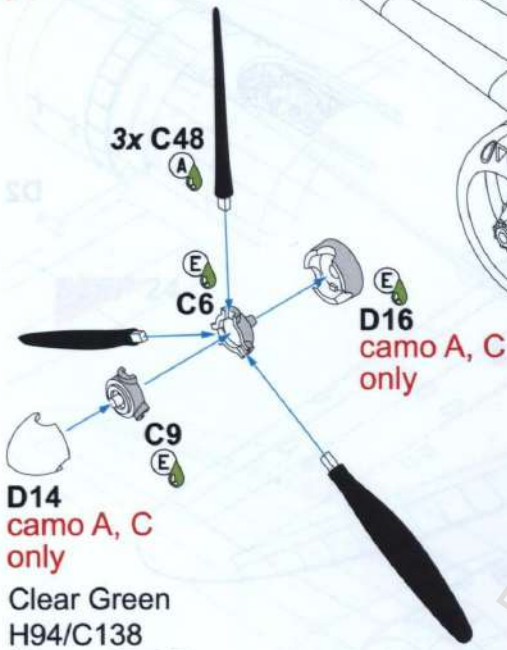

Step31

STEP 35

wire 0.2mm

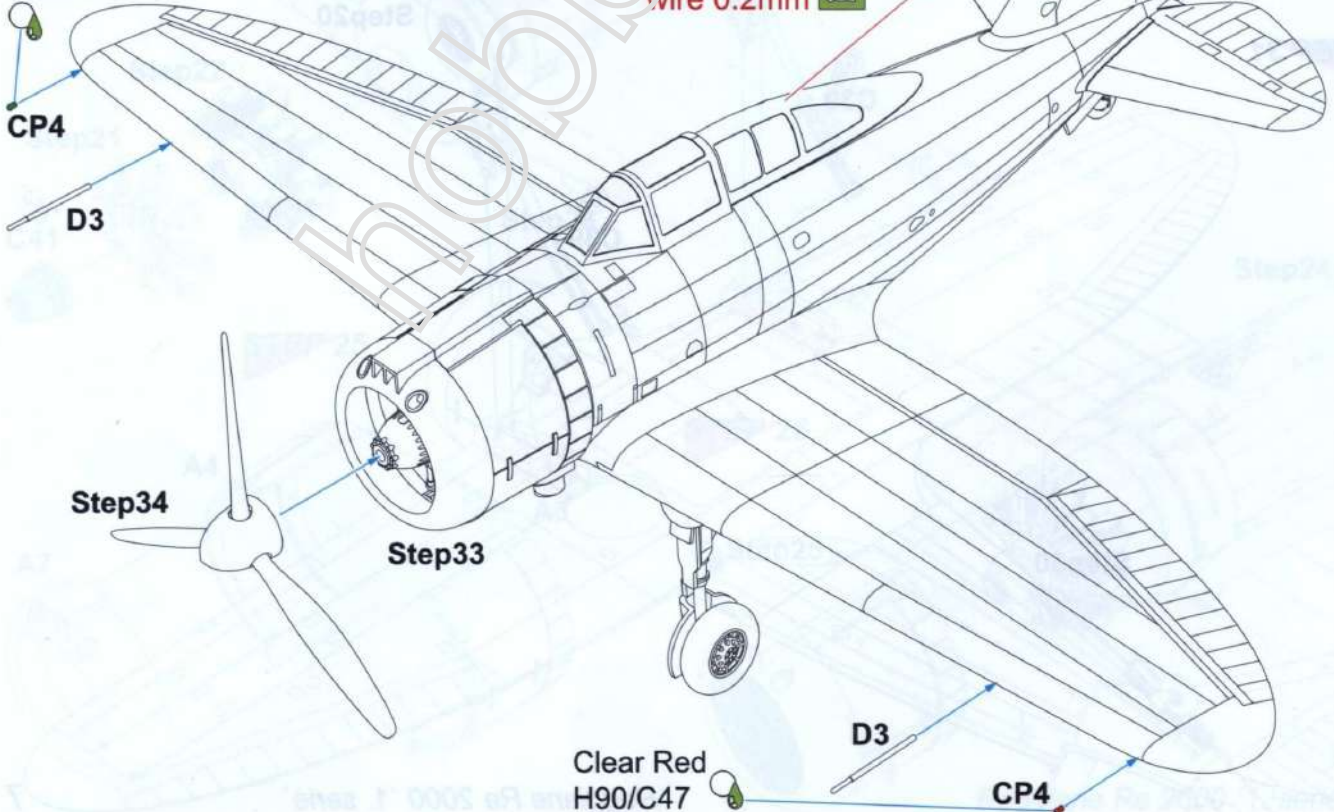

Step34

Step33

Clear Red H90/C47

CP4

Reggiane Re.2000 I. serie, MM.5069, Sezione Sperimentale (experimentální letka), 74a Squadriglia, 23 Gruppo Autonomo CT, Comiso, Sicílie, Itálie, jaro 1941. V té době byly Re.2000 používány k nočním útokům na Maltu. Je možné, že tento letoun používalo budoucí eso Ten. Giorgio Solaroli di Briona (11 sestřelů). Nechal se u tohoto stroje vyfotit.

Reggiane Re.2000 I. serie, MM.5069, Sezione Sperimentale (Experimental Section), 74a Squadriglia, 23 Gruppo Autonomo CT, Comiso, Sicily, Italy, Spring 1941. At the time, Re.2000s flew night attack sorties against the island of Malta. The illustrated machine might have been piloted by Ten. Giorgio Solaroli di Briona (later to become an ace with 11 victories) who posed in front of it for the benefit of the photographer's camera.

Camo A

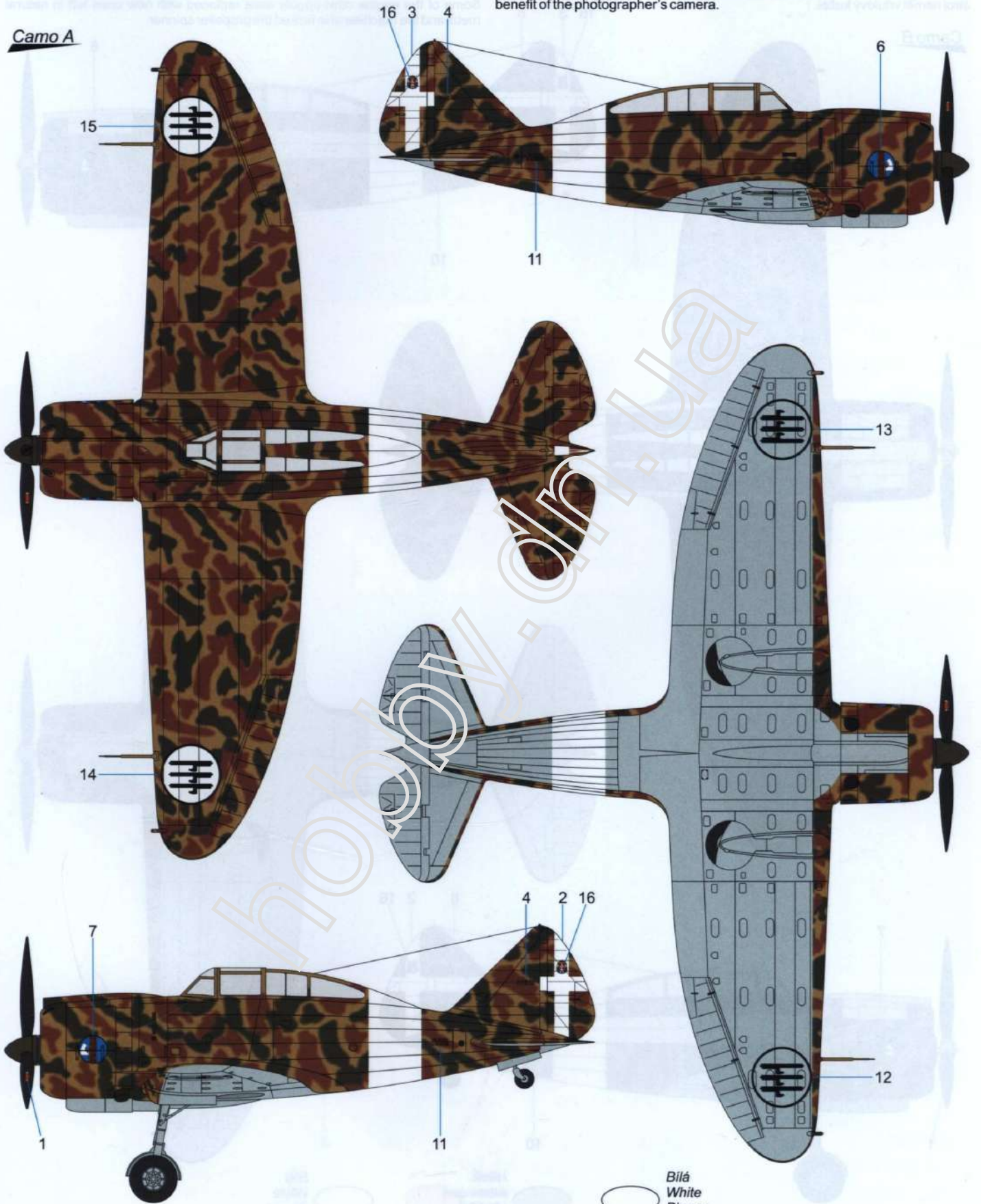

Písková
Sand
Giallo Mimetico
H79/ C39 90%
H44/ C51 10%

Tmavá zelená
Dark Green
Verde Mimetico Scuro
H303/ C303

Hnědá
Brown
Bruno Chiaro
H74/ C41

Bílá
White
Bianco
H1 / C1

Modrošedá
Blue Grey
Grigio Azzurro
H67/ C115

Matná černá
Matt Black
Nero
H12 / C33

Reggiane Re.2000 I. serie, MM.5068, Centro Sperimentale (experimentální centrum), Guidonia, Itálie, podzim 1941. Stroj pilotoval Ten. Adriano Mantelli, italské eso Španělské občanské války (15 vítězství) a byl používán dlouhou dobu k porovnávacím a jiným testům. To se projevilo na jeho zbarvení a opotřebení. Část panelů krytu motoru byla vyměněna za nové v barvě kovu a stroj neměl vrtulový kužel.

Reggiane Re.2000 I. serie, MM.5068, Centro Sperimentale (Experimental Centre), Guidonia, Italy, Autumn 1941. It was flown by Ten. Adriano Mantelli, an Italian ace pilot who had gained 15 victories in the Spanish Civil War. The machine was extensively used for comparative and other sorts of flight tests which accounts for the visible wear and tear of the airframe and its paintwork. Some of the engine cowl panels were replaced with new ones left in natural metal and the machine also lacked the propeller spinner.

Camo B

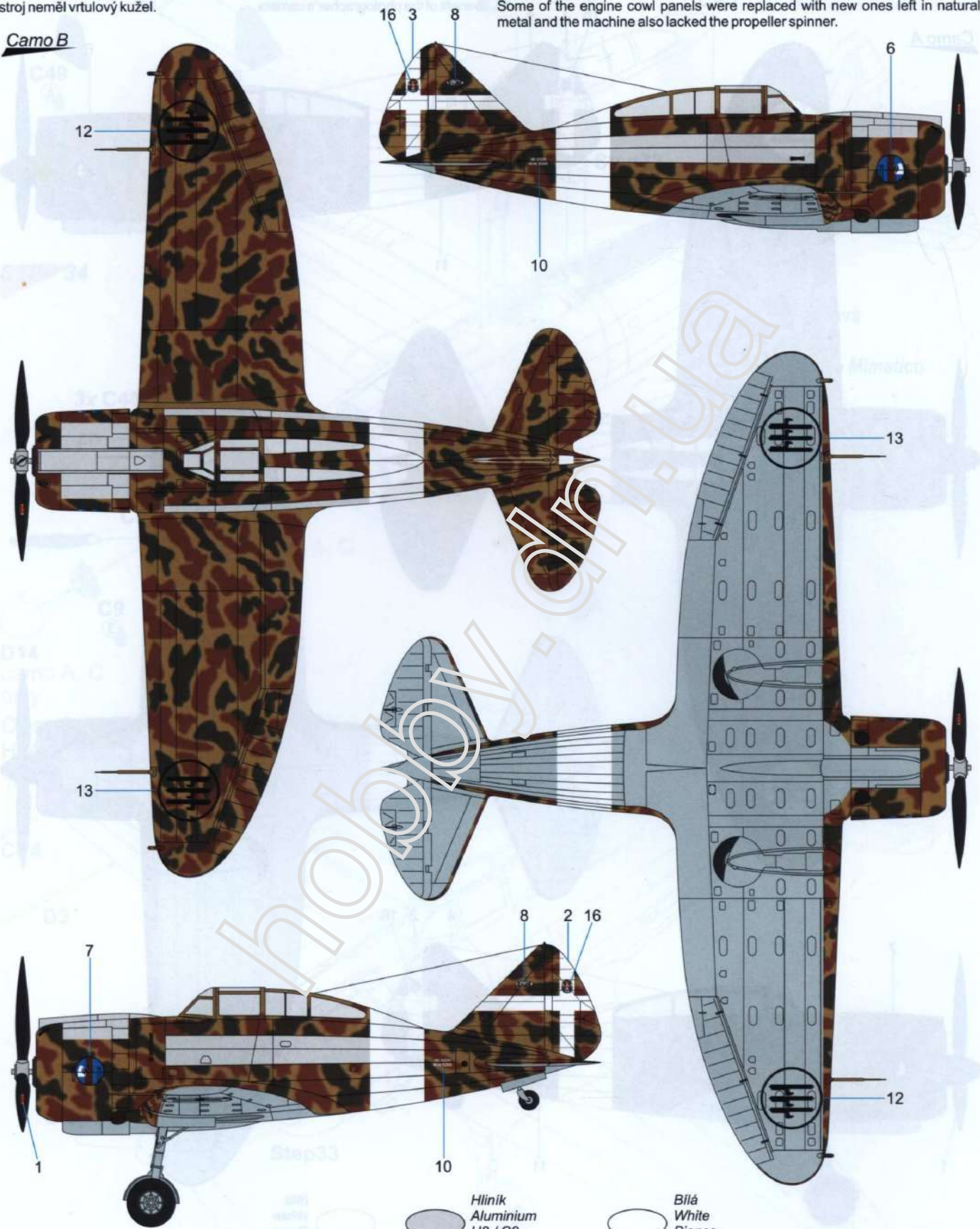

Písková
Sand
Giallo Mimetico
H79/ C39 90%
H44/ C51 10%

Tmavá zelená
Dark Green
Verde Mimetico Scuro
H303/ C303

Hliník
Aluminium
H8 / C8

Hnědá
Brown
Bruno Chiaro
H74/ C41

Bílá
White
Bianco
H1 / C1

Modrošedá
Blue Grey
Grigio Azzurro
H67/ C115

Matná černá
Matt Black
Nero
H12 / C33

Reggiane Re.2000 I. serie, MM.neznámé, Sezione Sperimentale (experimentální letka), 74a Squadriglia, 23 Gruppo Autonomo CT, Comiso, Sicílie, Itálie, jaro 1941.

Reggiane Re.2000 I. serie, MM.unknown, Sezione Sperimentale (Experimental Section), 74a Squadriglia, 23 Gruppo Autonomo CT, Comiso, Sicily, Italy, Spring 1941.

Camo C

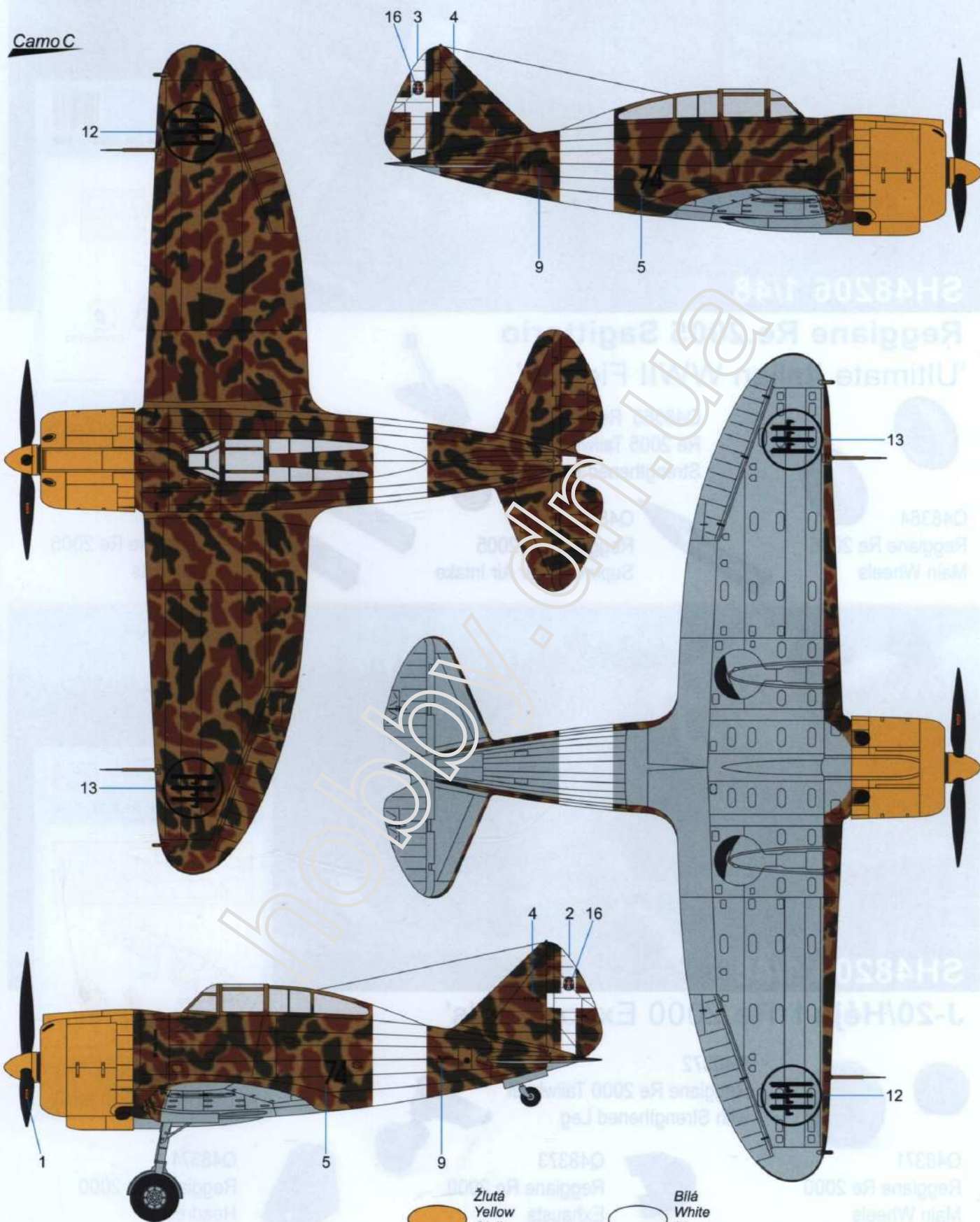

Písková
Sand
Giallo Mimetico
H79/ C39 90%
H44/ C51 10%

Tmavá zelená
Dark Green
Verde Mimetico Scuro
H303/ C303

Žlutá
Yellow
Giallo
H4/ C4

Hnědá
Brown
Bruno Chiaro
H74/ C41

Bílá
White
Bianco
H1/ C1

Modrošedá
Blue Grey
Grigio Azzurro
H67/ C115

Matná černá
Matt Black
Nero
H12/ C33