

SB2A-4 Buccaneer 'US Marines Bomber'

(EN) The predecessor of Brewster Buccaneer was carrier based bomber and reconnaissance two seater XSBA-1, designed in 1936 and test flown in 1943. It was accepted by US Navy for active duty. Small batch of 30 aircraft was produced in State factory Naval Aircraft Factory (designated by its producer as SBN-1) and were deployed for service after November 1940 when they were already obsolete.

Long development also stigmatized the usage of its successor. In 1939 US Navy ordered Brewster Company to design modern aircraft of the same class. Model 340 (according to company's designation) was ordered under official designation XSB2A-1. The prototype took off on June 17, 1941. It was powered by R-2600 engine and equipped with dummy machine gun turret. The development of the machine gun turret was unsuccessful. SB2A aircraft were ordered not only by US Navy but also by Great Britain (750 pcs) and Dutch East Indies (162 pcs). The start of the series production was very long, though. The first SB2A-2 without folding wings were delivered to US Navy no sooner than in 1943. Their armament consisted of two 12.7 mm machineguns in fuselage and two 7.62 mm machine guns in wings with twin mount of the same caliber in gunner's position. Fully enclosed bomb bay could carry bombs up to 450 Kg. Next version, SB2A-3 featured foldable wings and heavier armament. The machines originally produced for Dutch East Indies were taken over by US Marines and designated SB2A-4. All machines were used for training since combat units received SB2C Helldiver, its competitor, sooner. Brits took over only 469 machines with combat name Bermuda. The armament of these machine consisted of 7.7 mm machine guns. The British machines served as trainers as well. In total, 771 machines were produced.

Wingspan: 14.33 m, length: 11.95 m, max. speed at 3,660 m: 440 km/h, service ceiling: 7,595 m, range without bombs: 2,695 km

(CZ) Prapředkem stroje Brewster Buccaneer byl v roce 1934 zkonstruovaný a v roce 1936 zalétaný dvoumístný palubní bombardovací a průzkumný stroj XSBA-1. US Navy ho přijalo do výzbroje. Malou sérii 30 kusů ale vyrobilo ve státní továrně Naval Aircraft Factory a do služby tyto stroje (podle výrobce označené SBN-1) přišly až po listopadu 1940, kdy už byly zastaralé.

Dlouhý vývoj poznamenal také vznik a uplatnění jeho nástupce. US Navy objednalo v roce 1939 u firmy Brewster modernější letoun stejné kategorie. Model 340, dle firemního označení, byl objednán jako XSB2A-1. Prototyp vzlétl 17. června 1941. Stroj byl poháněn motorem R-2600 a vybaven maketou střelecké věže. Vývoj střelecké věže se však nezdařil. Stroje SB2A objednalo nejen US Navy, ale i Velká Británie (750 ks) a Holandská Východní Indie (162 ks). Rozeběhnutí sériové výroby trvalo ale velmi dlouho. První kusy SB2A-2 bez sklopných křídel dostalo US Navy až v roce 1943. Vyzbrojeny byly dvěma kulomety 12,7 mm v přídi, dvěma kulomety 7,62 mm v křídle a dvoukulomet stejné ráže ovládal střelec. Do uzavřené pumovnice se vešly pumy do hmotnosti 450 kg. Další verze SB2A-3 měla sklopná křídla a silnější výzbroj, stroje původně vyrobené pro Holandskou Východní Indii převzalo US Marines jako SB2A-4. Všechny stroje se používaly k výcviku, u bojových jednotek předběhl Buccaneera konkurenční SB2C Helldiver. Britové odebrali pouze 469 kusů strojů s bojovým jménem Bermuda. Ty byly vyzbrojeny zbraněmi ráže 7,7 mm. Také britské stroje sloužily k výcviku a tahání terčů. Celkem bylo vyrobeno 771 kusů.

Rozpětí: 14,33 m, délka: 11,95 m, max. rychlost v 3 660 m: 440 km/h, dostup: 7 595 m, dolet bez pum: 2 695 km

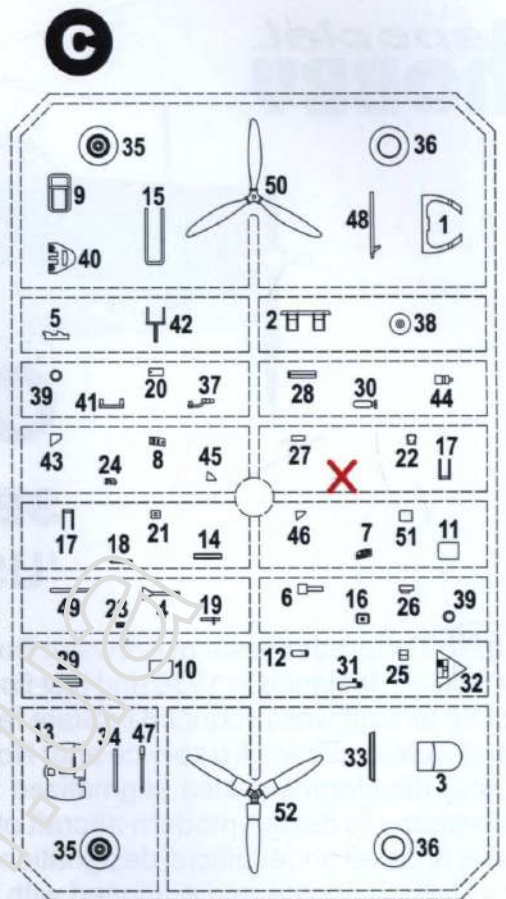
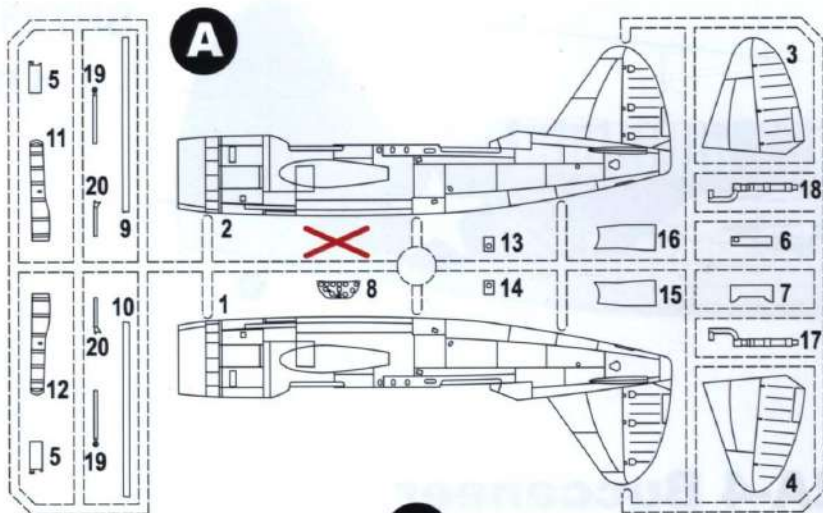

X Do not use this part
Tento díl nepoužít

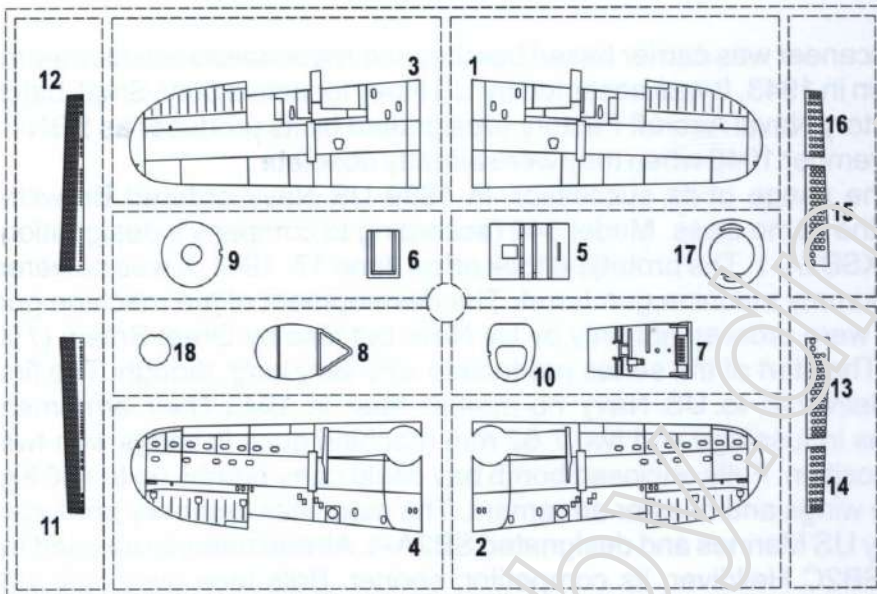

Clear Parts (CP)

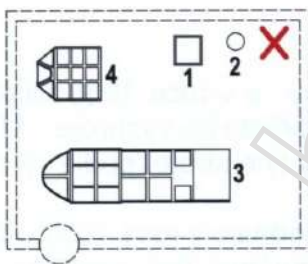
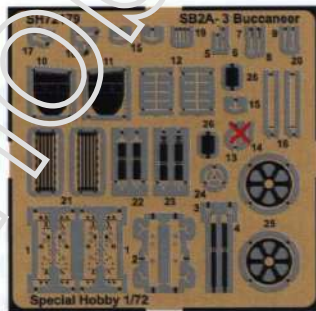
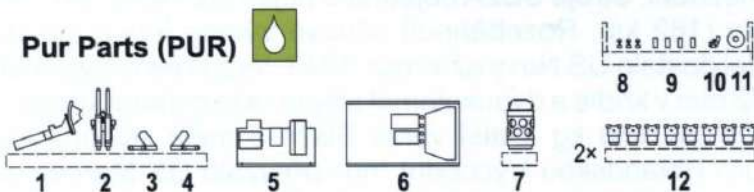

Photo-Etched Parts (PP)



Pur Parts (PUR)



Barvy GUNZE/ GUNZE Colour No.

A	Flat Black / černá matná	H12/C33
B	Gloss Black / černá lesklá	H2/C2
C	Interior Green / interiér. zelená	C364
D	Linen (Tan) / plátno	H27/C44
E	Leather / kůže	H17/C29
F	Khaki	H81/C55
G	White / bílá	H21/C69
H	Aluminium / hliník	H8/C8
I	Neutral Grey / neutrální šedá	H53/C13
J	Tire Black / barva pneu	H77/C137
K	Burnt Iron / opálený kov	H76/C61
L	Dark Iron / tmavý kov	H28/C78
M	Chrom Silver / chromová	MC211

SYMBOLS



OPTIONAL
MOŽNOST VOLBY
NACH BELIEBEN
OPTION



INSTANT CYANOACRYLATE GLUE
POUŽIT KYANOAKRYLÁTOVÉ LEPIDLO
ZYANOAKRYLATKLEBER
ADHESIF CYANOACRYLAT



BEND
OHNOUT
BIEGEN
COURBER



SCRATCH BUILD
ZHOTOVIT NOVÉ
FERTIGSTELLEN
ACHEVER



CUT OFF/DRILL
ŘEZAT/VRTAT
ENTFERNEN
DETACHER



GSI
colours code

COLOUR
NATRÍT
FARBEN
PEINDRE

1

2

3

4

5

6

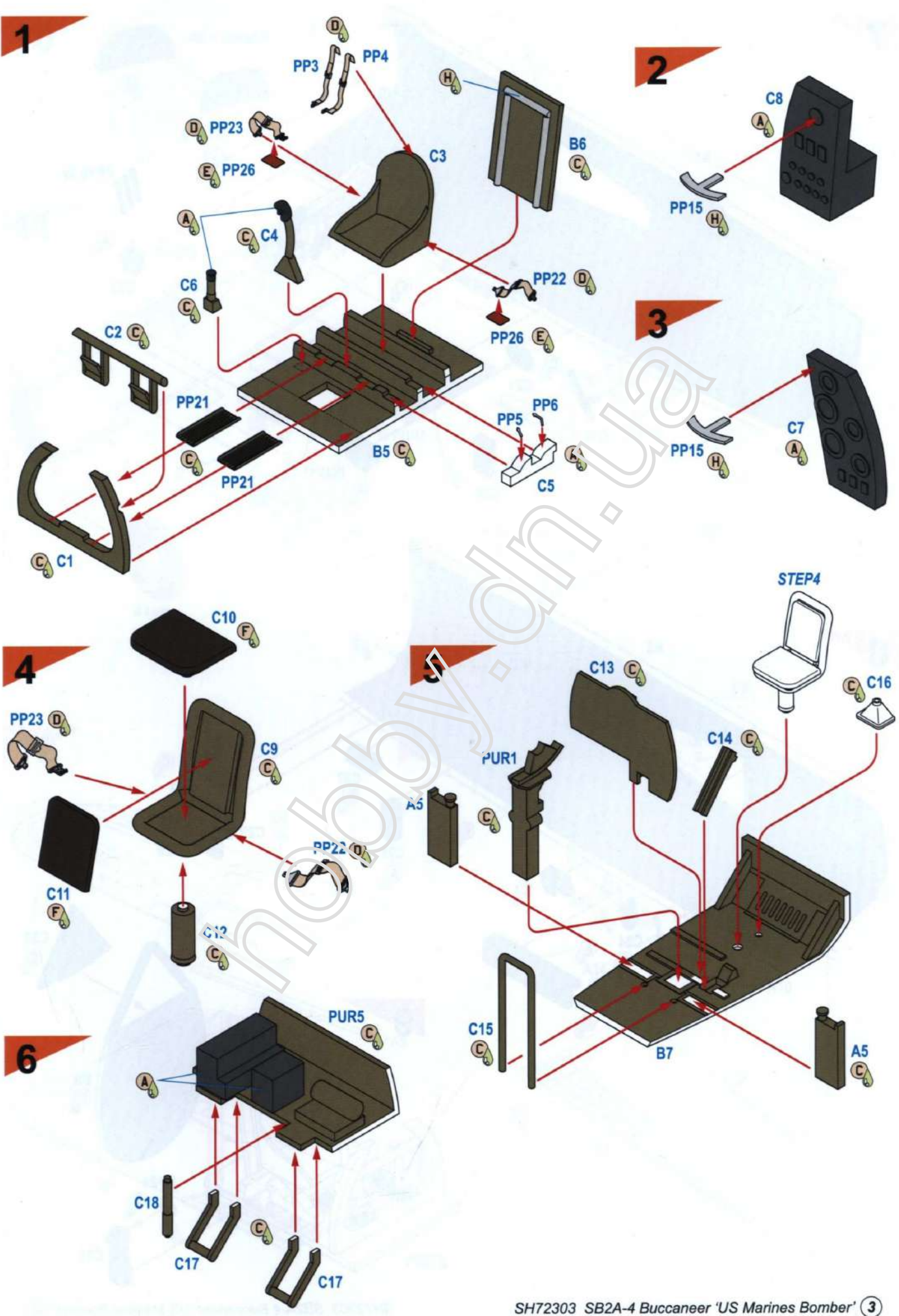

7

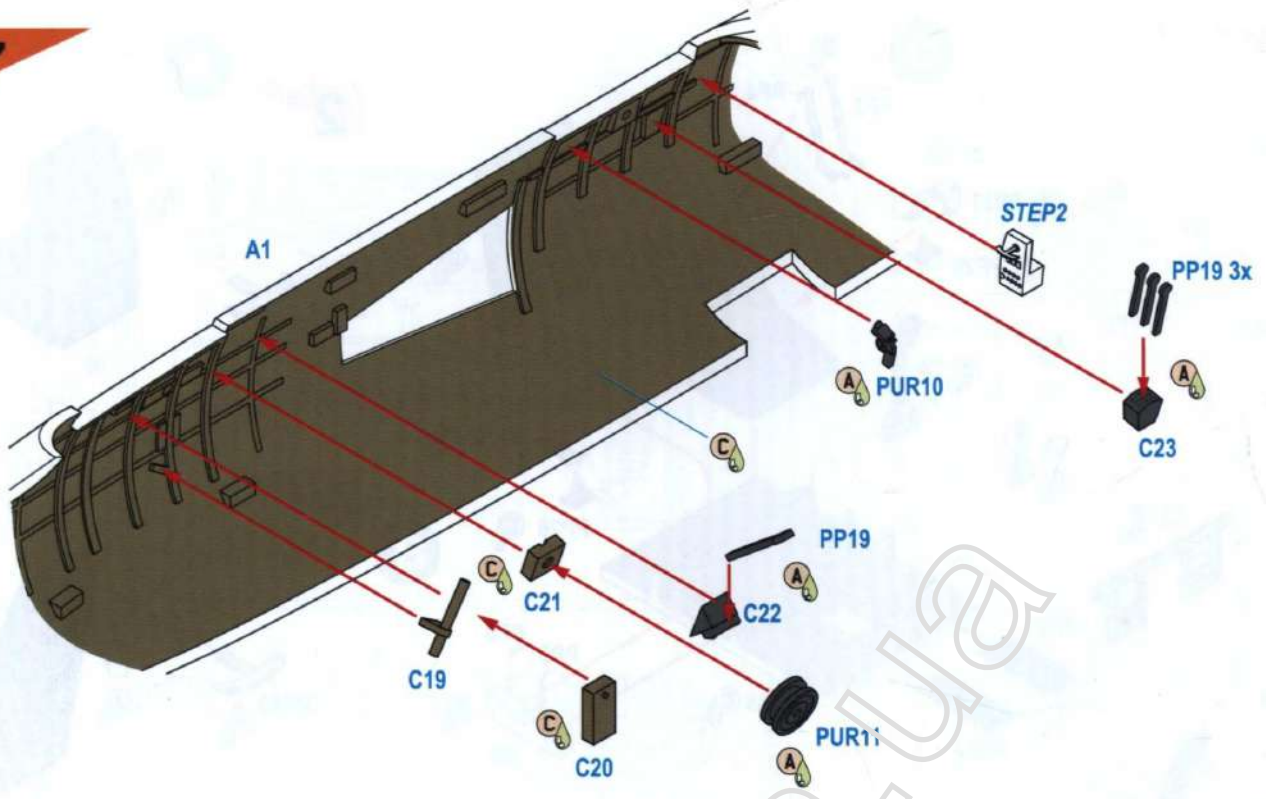

8

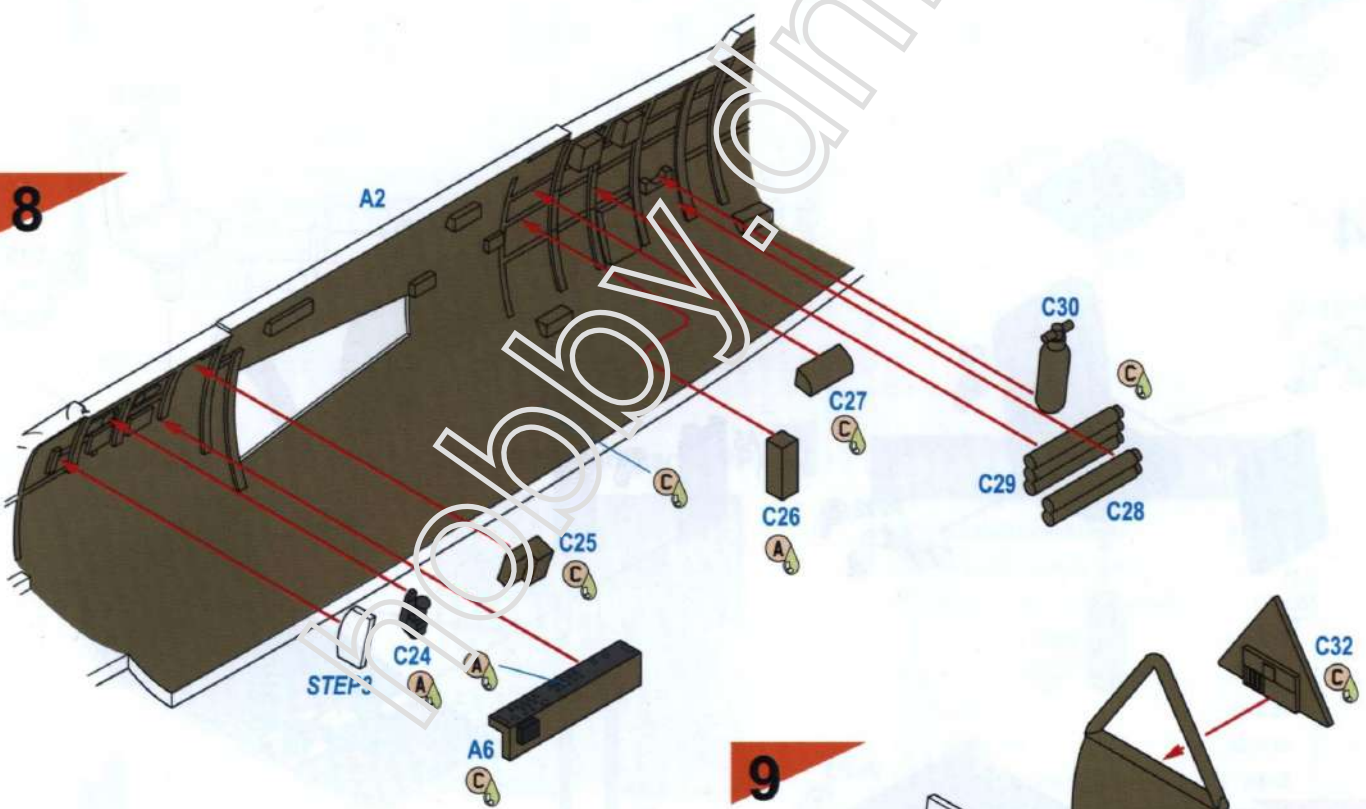

9

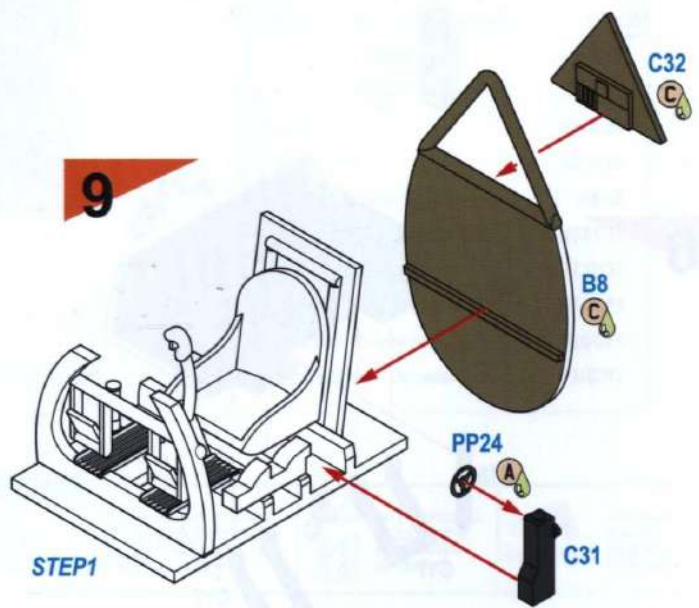

10



11

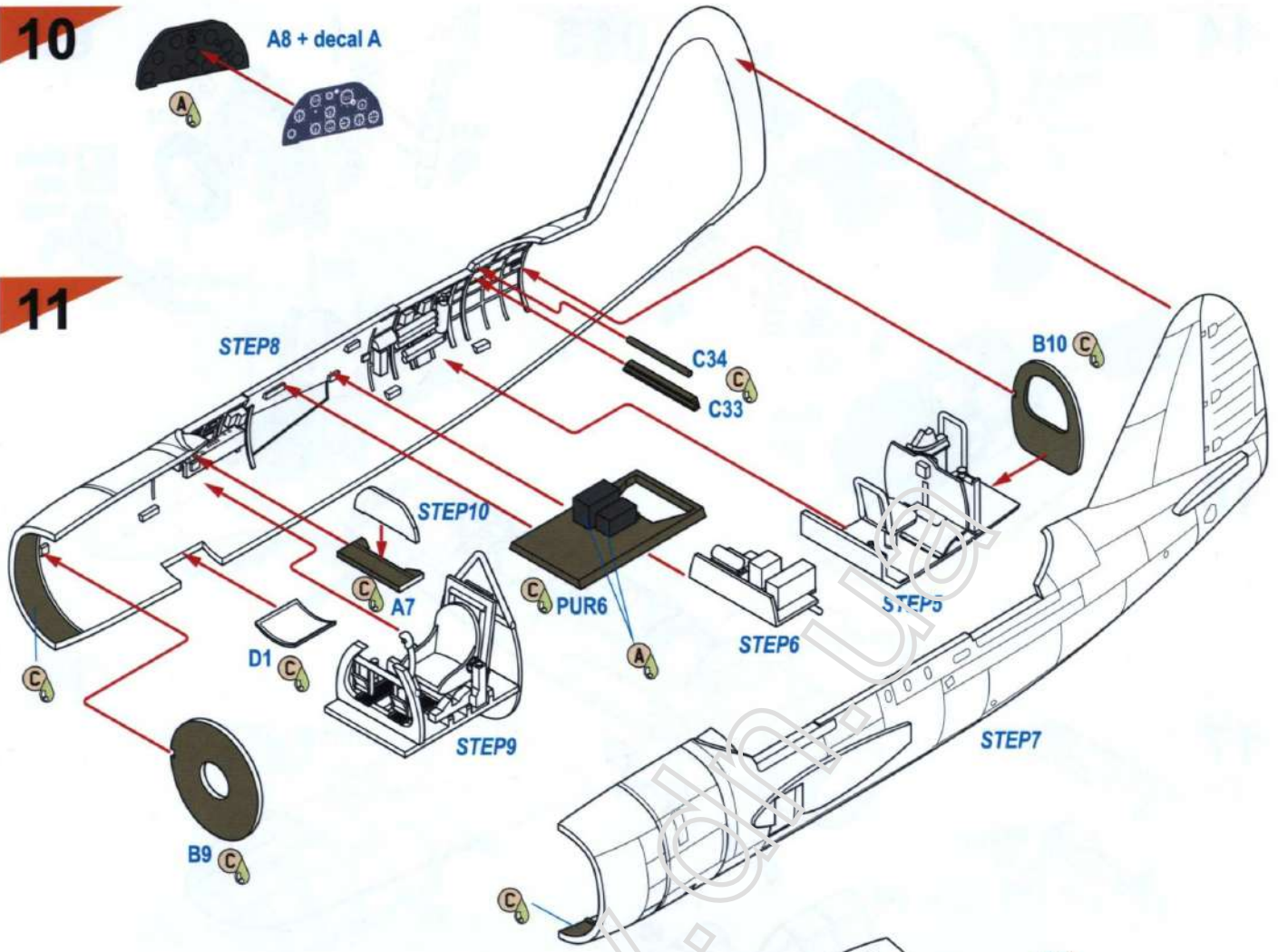

12

13

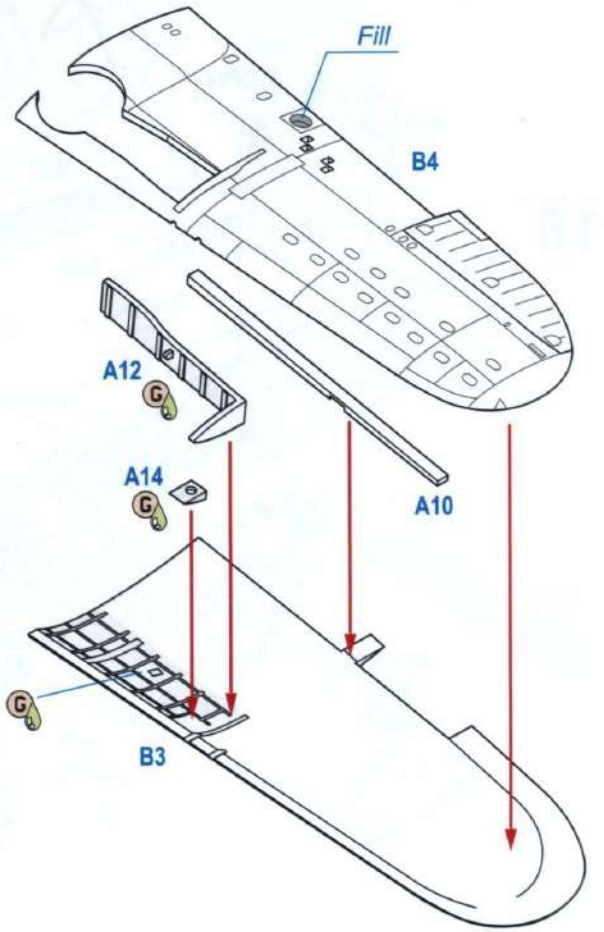
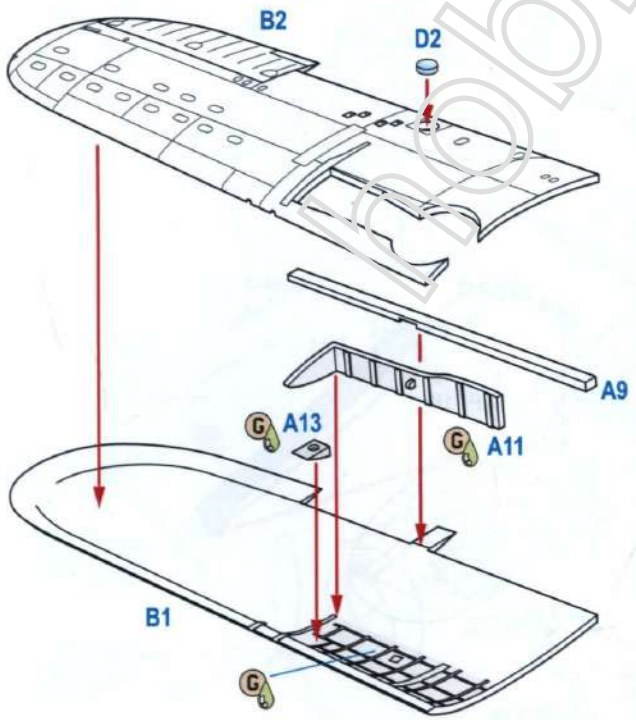

14

? Camo
A/D
PP25

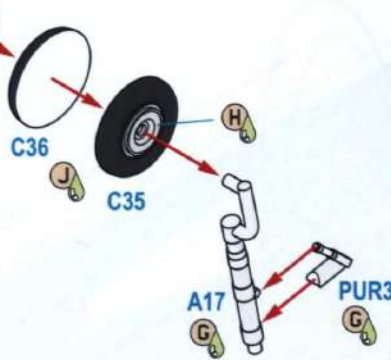

15

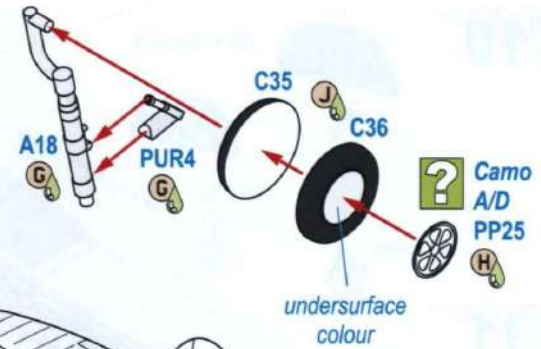

16

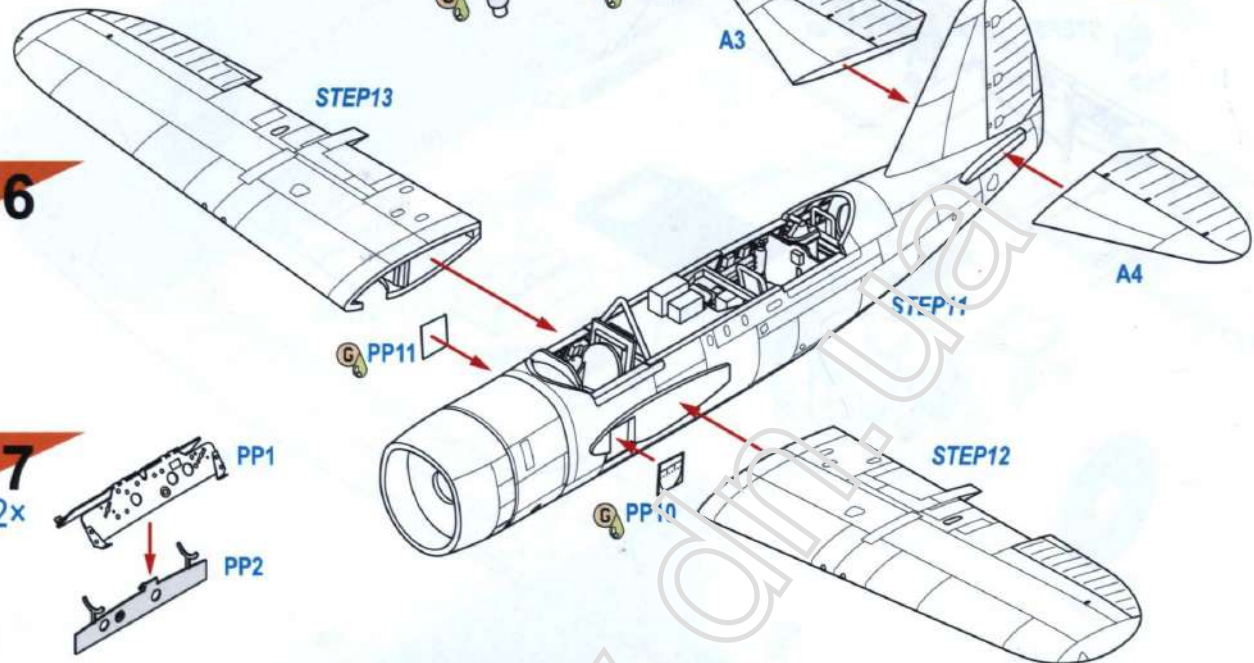

17
2x

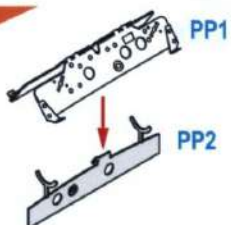

18

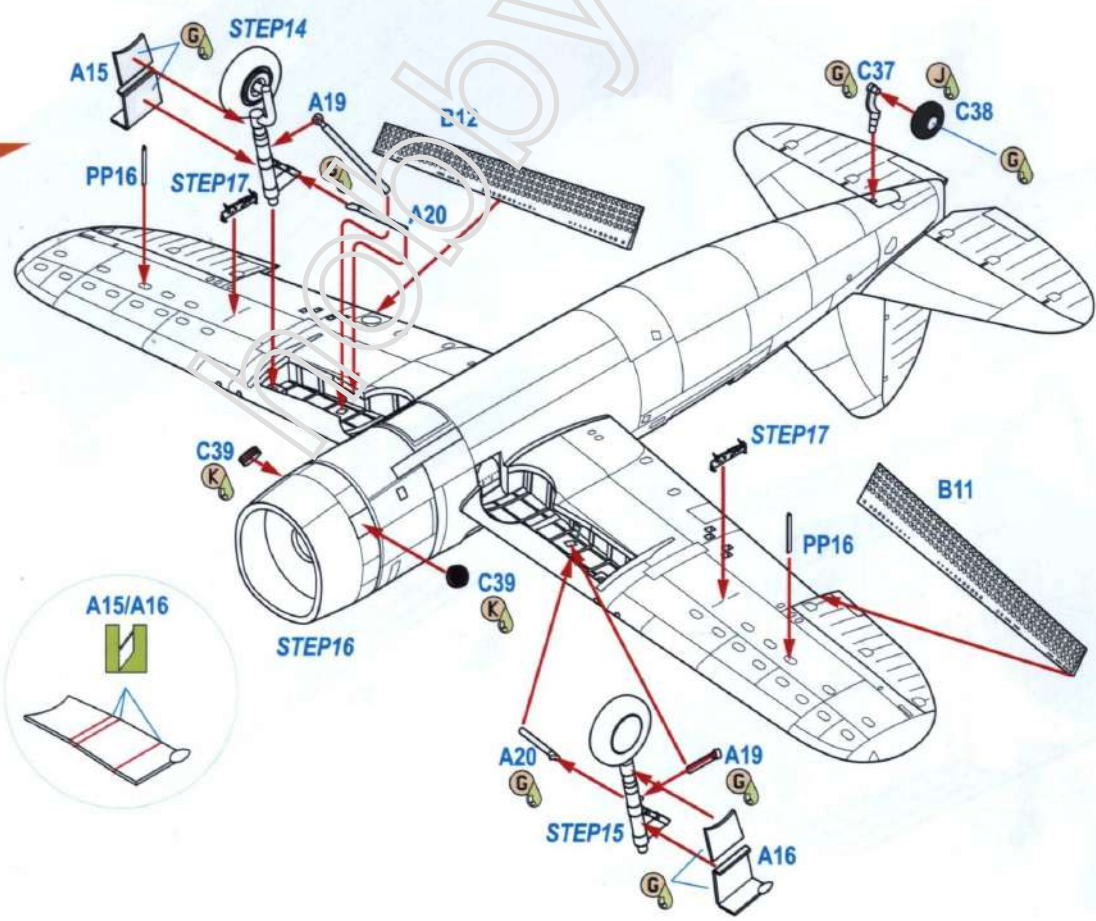

19

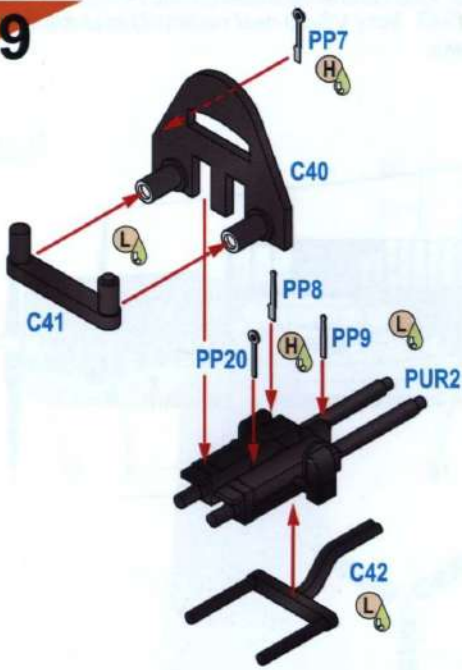

20



21

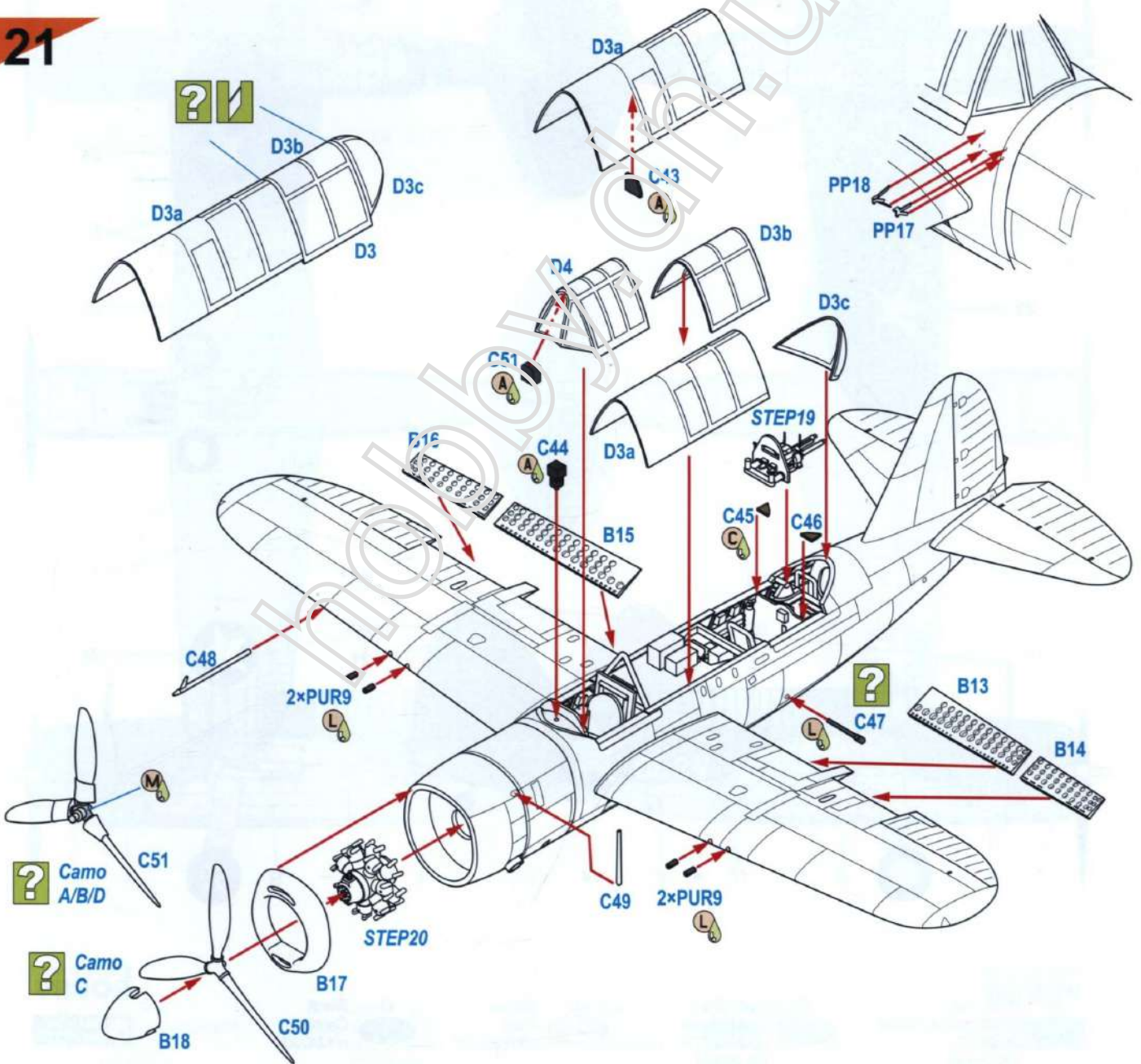

SB2A-4, VS-30, VSB Operation Training Unit, NAS Vero Beach, Florida, USA, 1943. The markings on the wing upper surfaces were quite faded on VS-30.

SB2A-4, VS-30, VSB Operation training Unit, NAS Vero Beach, Florida, USA, 1943. Stroj VS-30 nesl na horní ploše křídla velmi vyšisované znaky.

Camo A

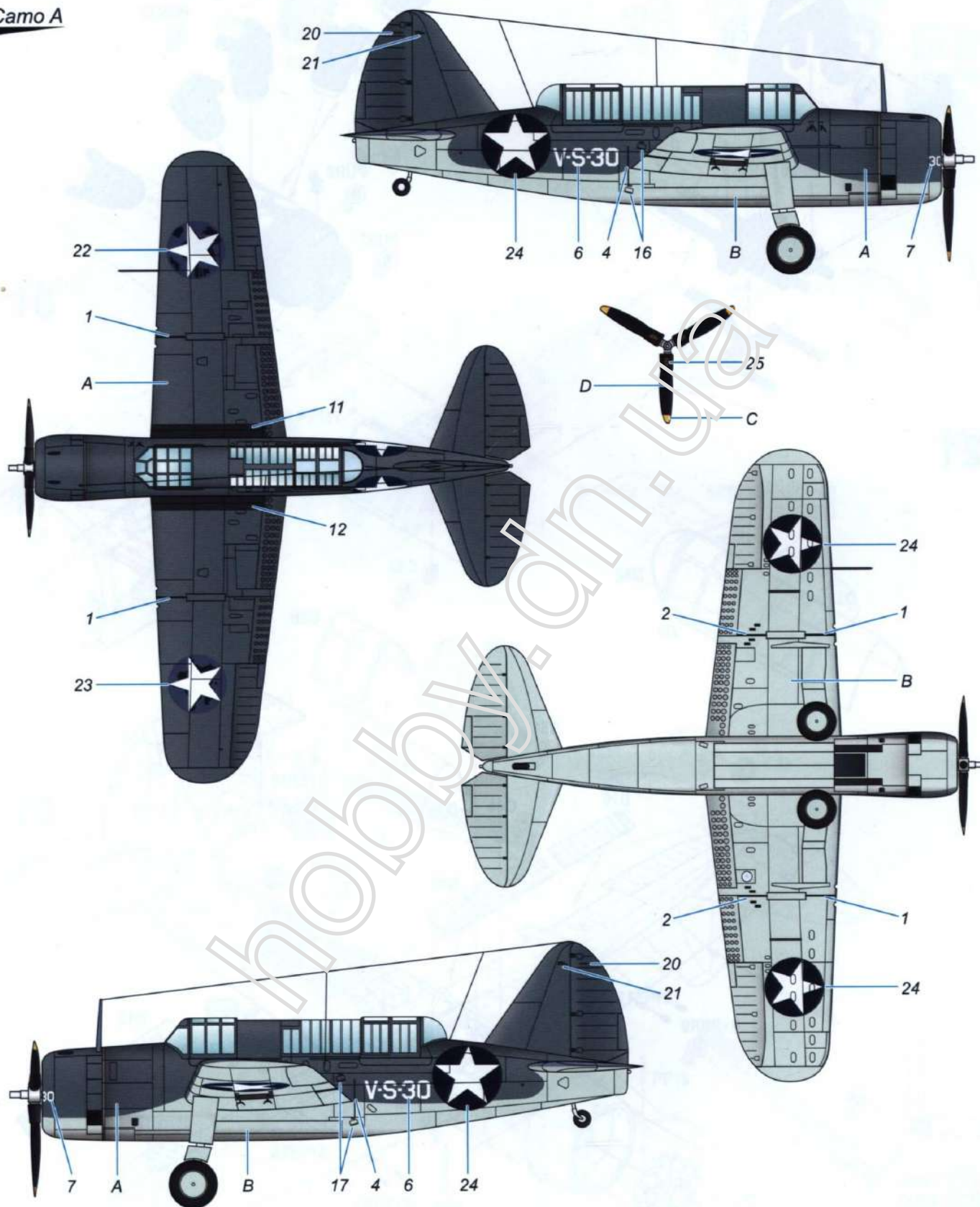

A Blue Grey
Přechodová modrá
H42/C72
FS 35189

B Light Grey
Světle šedá
H325/C325
FS 36440

C Yellow
Žlutá
H329/C329

D Black
Černá
H12/C33



SB2A-4, 16, BuNo 29318, VMF (N)-532, Cherry Point, North Carolina, USA, July 1943.

SB2A-4, 16, BuNo 29318, VMF (N)-532, Cherry Point, Severní Karolína, USA, červenec 1943.

Camo B

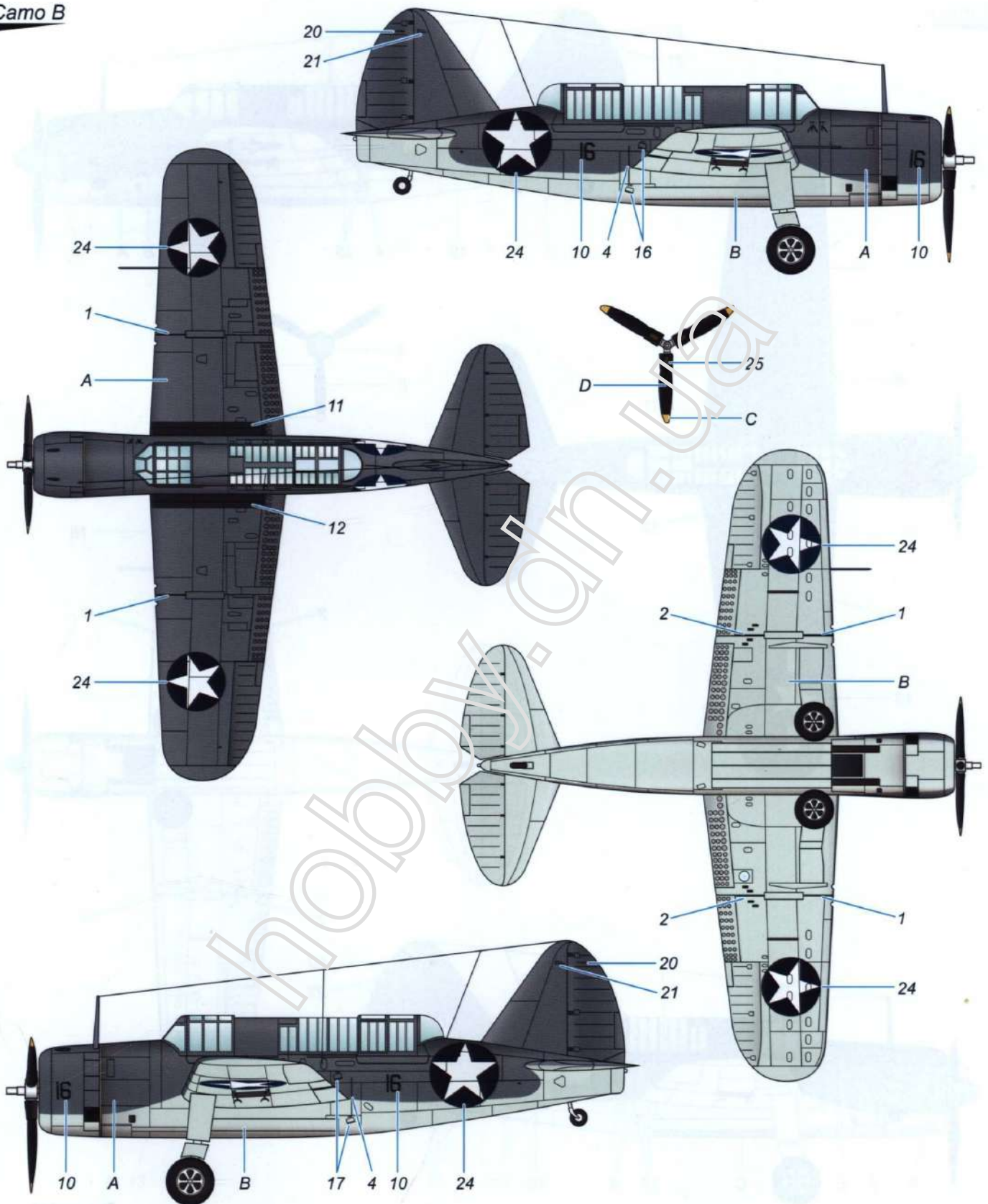

A Blue Grey
Přechodová modrá
H42/C72
FS 35189

B Light Grey
Světle šedá
H325/C325
FS 36440

C Yellow
Žlutá
H329/C329

D Black
Černá
H12/C33



SB2A-4, VS-34, VSB Operation Training Unit, NAS Vero Beach, Florida, USA, 1944. Machine VS-34 flew bearing the newer three-tone camouflage scheme combined with the later style of national markings.

SB2A-4, VS-34, VSB Operation training Unit, NAS Vero Beach, Florida, USA, 1944. Stroj VS-34 létal v novější třibarevné kamufláži a s novějším typem znaků.

Camo C

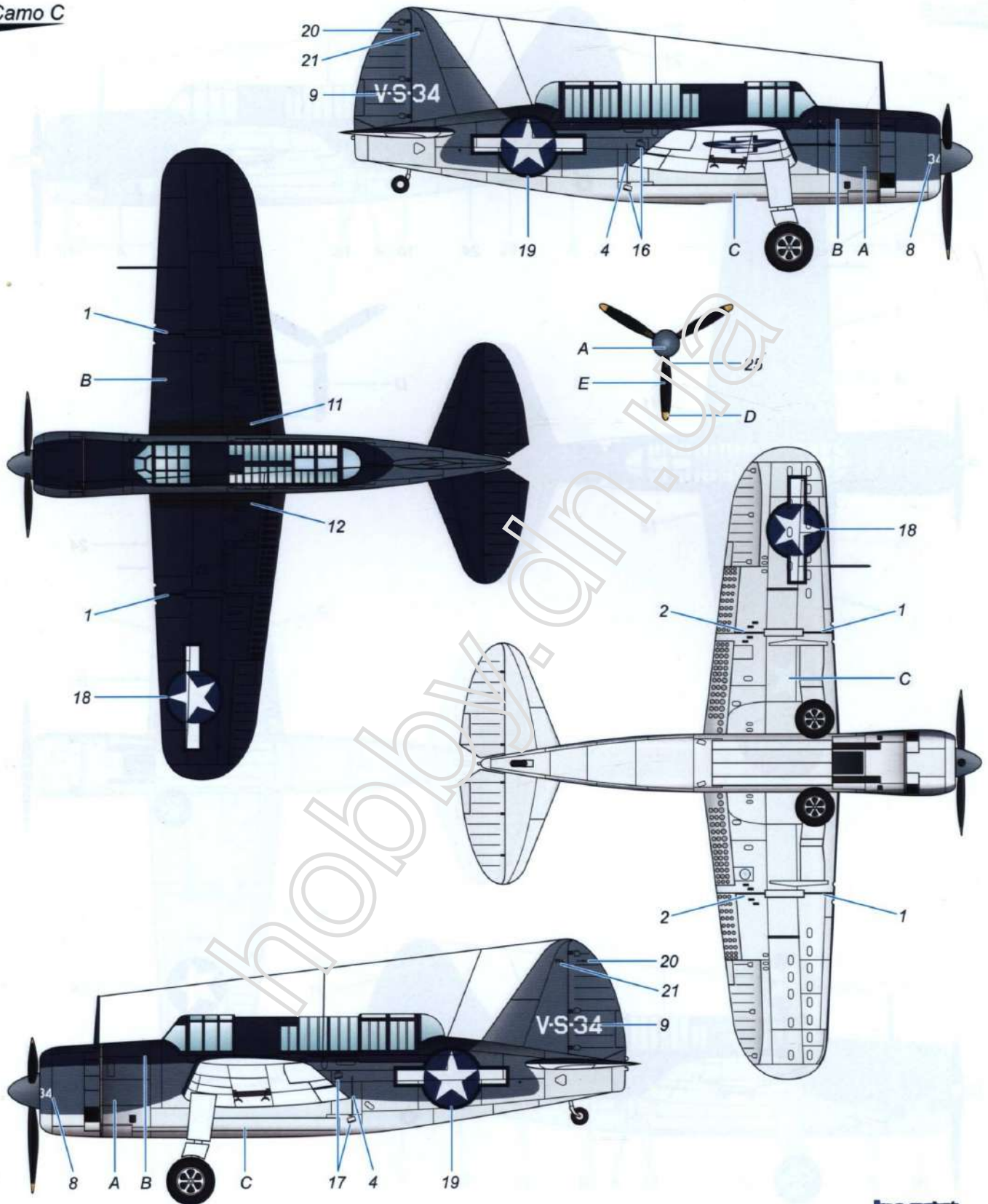

A Intermediate Sea Blue
Přechodová modrá
C366
FS 35164

B Non Specular Sea Blue
Matná mořská modrá
C365
FS 35042

C White
Bílá
H21/C69
FS 37880

D Yellow
Žlutá
H329/C329

E Black
Černá
H12/C33



SB2A-4, BD-705, ML-KNIL (Royal Netherlands East Indies Army Air Force), Dutch East Indies, 1942. This illustration shows a fictitious Dutch machine as it might have looked had their delivery taken place in time.

SB2A-4, BD-705, letectvo ML-KNIL, Holandská Východní Indie 1942. Fiktivní stroj. Takto mohly vypadat tyto stroje, pokud by došlo včas k jejich dodání.

Camo D

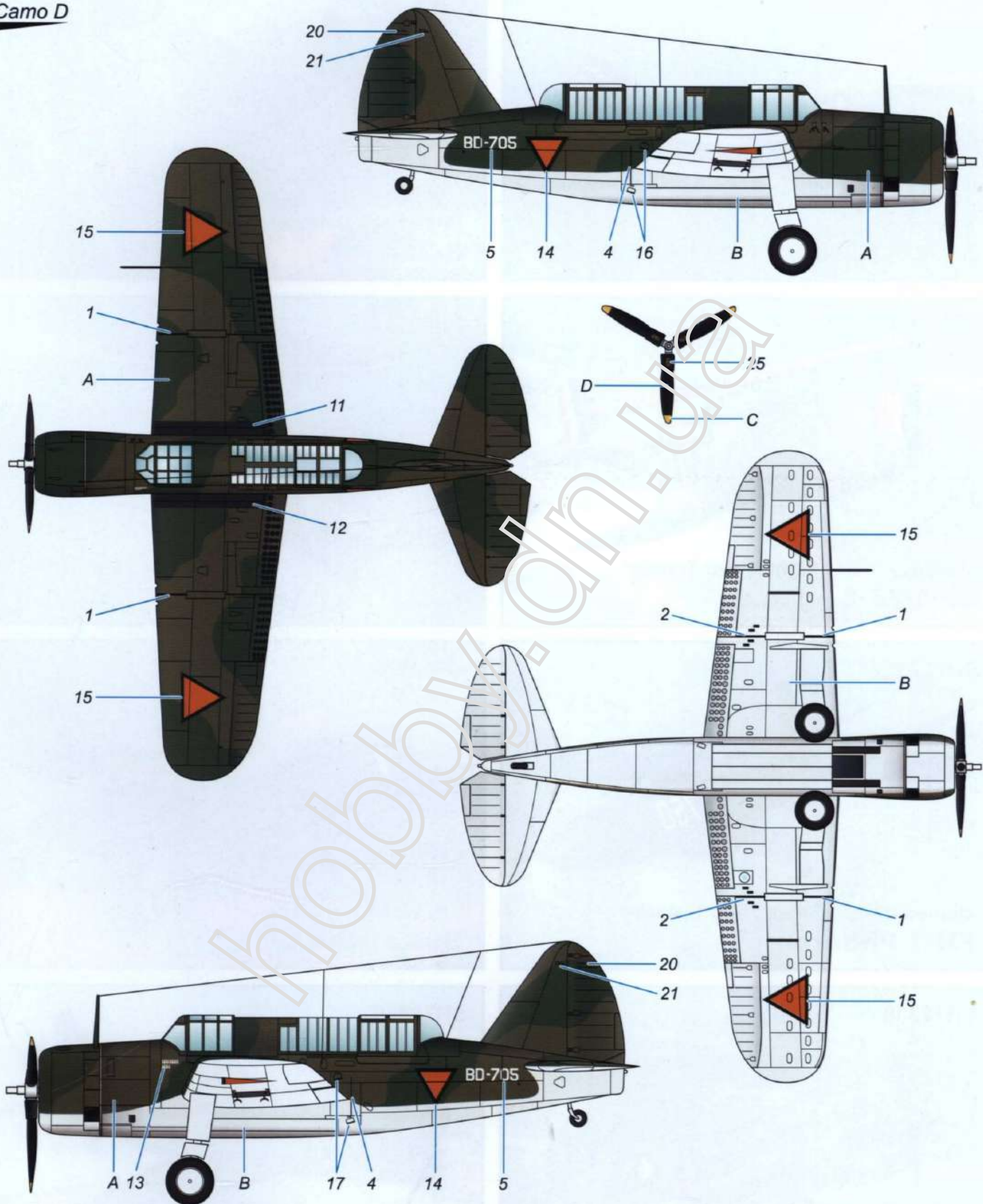

- A** Olive Drab
Nevýrazná olivová
H52/C12
FS 30118
- B** Medium Green
Střední zelená
H302/C302
FS 34092
- B** Aluminium Dope
Hliníkový nátěr
H08+11 / C08+62
- D** Yellow
Žlutá
H329 / C329
- F** Black
Černá
H12 / C33

