

## Dornier Do 27

### Civilian Service

#### NÁVOD / INSTRUCTIONS

#### CZ – Historie

Dr Claudius Dornier ml. odešel po druhé světové válce, podobně jako jiní němečtí konstruktéři do zahraničí. Obával se zákazu stavby letadel. Založil ve Španělsku továrnu OTEDA (Oficinas Técnicas Dornier). Zde zkonstruoval v polovině padesátých let na objednávku španělského ministerstva letectví čtyřmístný celokovový homoplošník s vlastnostmi STOL označený Dornier Do 25. Dva prototypy byly postaveny továrnou CASA. První prototyp byl poháněn motorem Elizalde Tigre G-IV-B, druhý Continentalem O-470-J. Oba motory se ale ukázaly slabé. V rekonstruované továrně Dornier v Německu vznikl na základě Do 25 nový prototyp Dornier Do 27 s motorem Lycoming GSO-480-B1B6. Dornier Do 27 byl přijat do sériové výroby a stal se prvním velkosériově vyráběným letadlem v Německu po druhé světové válce. Celkově bylo vyrobeno 428 ks letadel, které odebíraly postupně v několika verzích tři složky nově budovaných německých ozbrojených sil, letectvo, námořnictvo i pozemní síly. Zároveň se ve Španělsku rozeběhla výroba padesátiusové série pro španělské letectvo s označením CASA C-127/U.9. Dornier Do 27 byl vyráběn v několika verzích lišících se podvozkem, typem motoru a použité vrtule, dvojitým nebo jednoduchým řízením a tvarem svislé ocasní plochy. Do 27 byl dodáván mnoha evropským ozbrojeným silám (např. Portugalsko, Belgie, Švédsko, Švýcarsko), létal ale i jinde ve světě. Kromě několika afrických zemí i v Brazílii, státu Izrael a Turecku. Mimo vojenských sil se Do 27 dočkaly široké uplatnění u civilních uživatelů. Letouny byly s oblibou používány „bush pilots“ v drsných podmínkách nepravidelné dopravy v Africe a Jižní Americe. V Evropě byly používány jako turistické a k vysazování parašutistů. Nejslavnějším civilním Do 27 byl patrně „zebrí stroj“ Bernharda Grzimeka použitý při filmování zvěře v Africe. Některé civilní stroje létají dodnes.

Rozpětí: 12,0 m, délka: 9,6 m, max. rychlost: 210 km/h, dolet 1 350 km, dostup: 5 000 m.

#### EN – History

In the post war year, many German aircraft designers feared the possible ban on aircraft production and begun to leave the country. Among them also Claudius Dornier Jr., the son of the famous German WW2 aircraft builder. He settled in Spain where he founded company named Oficinas Técnicas Dornier (OTEDO). In the middle 50's, the Spanish Air Ministry was looking for a new STOL aircraft and having received the order, Dornier designed the Dornier Do 25 type, a high wing aircraft for a crew of four. Two prototype airframes were built by CASA company in Spain, while in Germany, in rebuilt Dornier works, the type was redesigned to the Do 27, powered by the Lycoming GSO-480-B1B6 engine. This type was also finally put into production, becoming the first aircraft to be mass-produced in Germany after the war. In total, 428 airframes were built in several different versions and they were operated by all three services of the newly built German military, ie. the air force, navy and land forces. At the same time, a 50-unit batch was also produced in Spain for their military, named the CASA C-127/U.9. The type's many versions differed mainly by the style of the undercarriage, engine and propeller used, the shape of the tail fin or by having either single or twin controls in the cockpit. The Dornier Do 27 was not only used by air forces of many European countries, namely by Portugal, Belgium, Sweden, Switzerland and some others, but also elsewhere over the globe. It could be seen flying in several African countries, in the State of Israel and also in Turkey. The type found its way to civil aviation market too and was quite liked by so-called bush pilots for its excellent performance in harsh conditions of irregular transport lines in Africa or South America. In Europe, the Do 27 served as touring or skydiving aircraft.

Wingspan: 12.0 m, Length: 9.6 m, Max. Speed 210 kmh, Range: 1,350 km, Ceiling: 5,000 m.

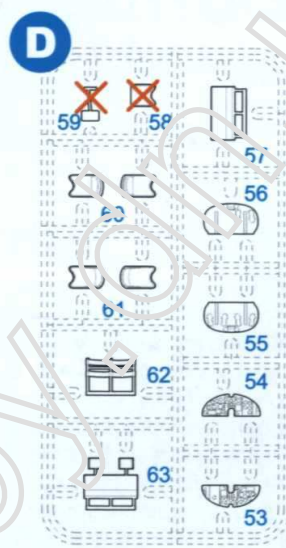
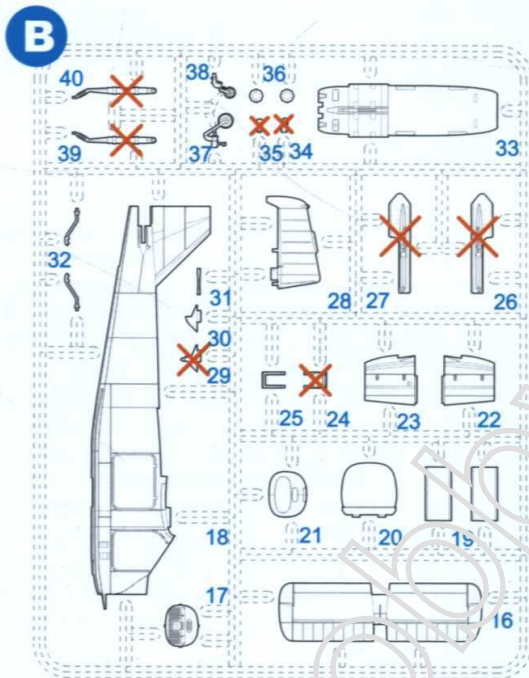
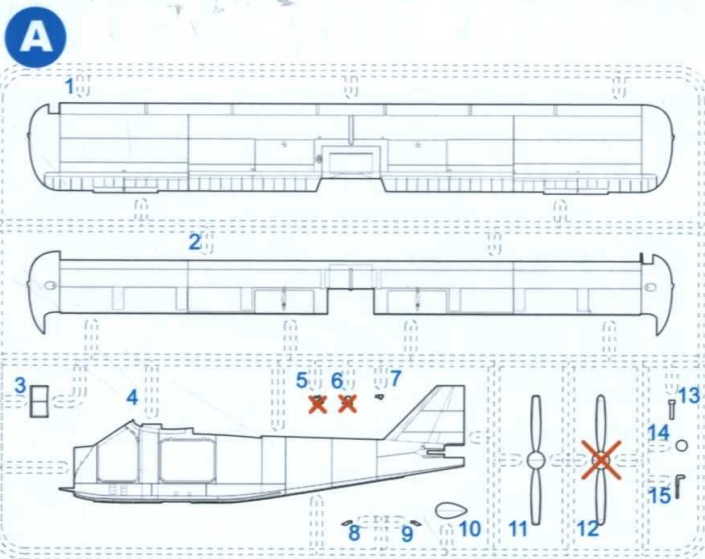

### CLEAR PARTS (CF)

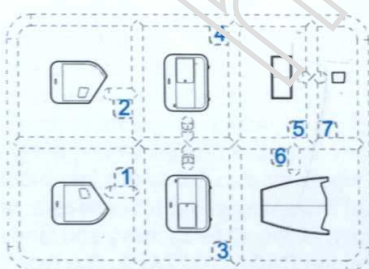

### PHOTO-ETCHED PARTS (PP)



Tento díl nepoužít.  
Do not use this part.

### Barvy GUNZE/ GUNZE Colour No.

<b>A</b>	Černá / Black	H12/C33
<b>B</b>	Šedá / Gray	H325/C325
<b>C</b>	Hliník / Aluminium	H8/C8
<b>D</b>	Hnědočervená / Leather	H47/C41
<b>E</b>	Hnědá / Brown	H310/C310
<b>F</b>	Plátno / Linen (Tan)	H27/C44
<b>G</b>	Červená / Red	H3/C3
<b>H</b>	Opálený kov / Burnt Iron	H76/C61
<b>I</b>	Barva pneu / Tire Black	H77/C137
<b>J</b>	Červená čirá / Clear Red	H90/C47
<b>K</b>	Zelená čirá / Clear Green	H94/C138
<b>L</b>	Chrom. stříbrná / Chrome Silver	MC211
<b>M</b>	Bílá / White	H1/C1
<b>N</b>	Žlutá / Yellow	H329/C329
<b>O</b>	Citronově zelená / Lime Green	H50

### SYMBOLS

MOŽNOST VOLBY  
OPTIONAL  
NACH BELIEBEN  
OPTION

POUŽÍT KYANOAKRYLÁTOVÉ LEPIDLO  
INSTANT CYANOACRYLATE GLUE  
ZYANOAKRYLATKLEBER  
COLLE CYANOACRYLATE

OHNOUT  
BEND  
BIEGEN  
COURBER

ZHOTOVIT NOVÉ  
SCRATCH BUILD  
FERTIGSTELLEN  
ACHEVER

REZAT/VRTAT  
CUT OFF/DRILL  
ENTFERNEN  
COUPER/PERCER

NATŘÍT  
COLOUR  
FARBEN  
PEINDRE

1

For camo A, use parts: 2× 61, 19, 62  
For camos B/C use parts: 2× 60, 2× 19, 63, 57

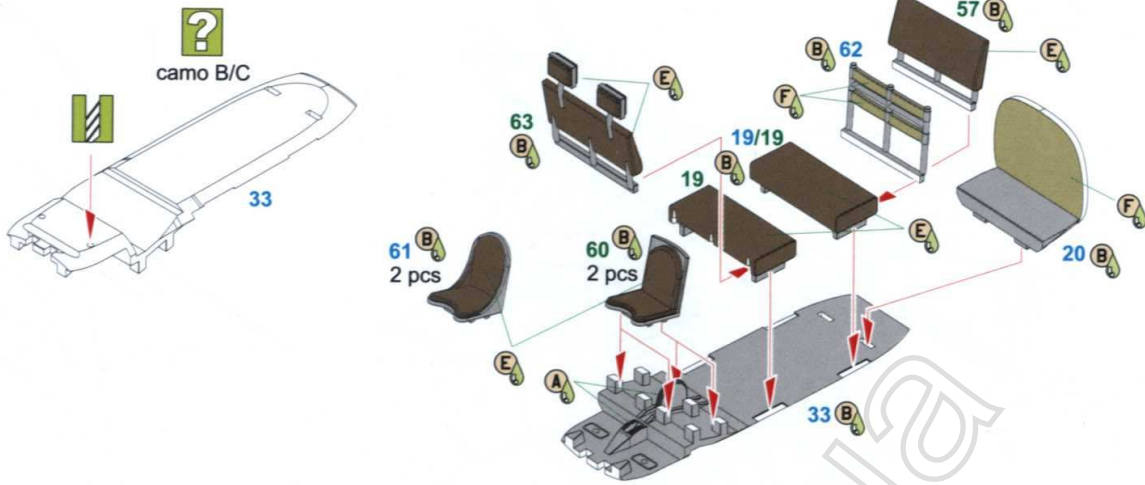

2

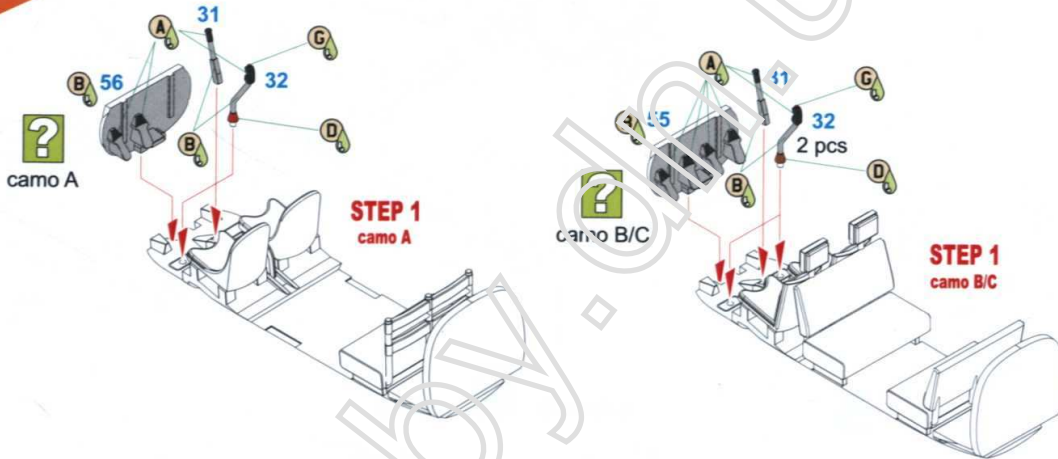

3

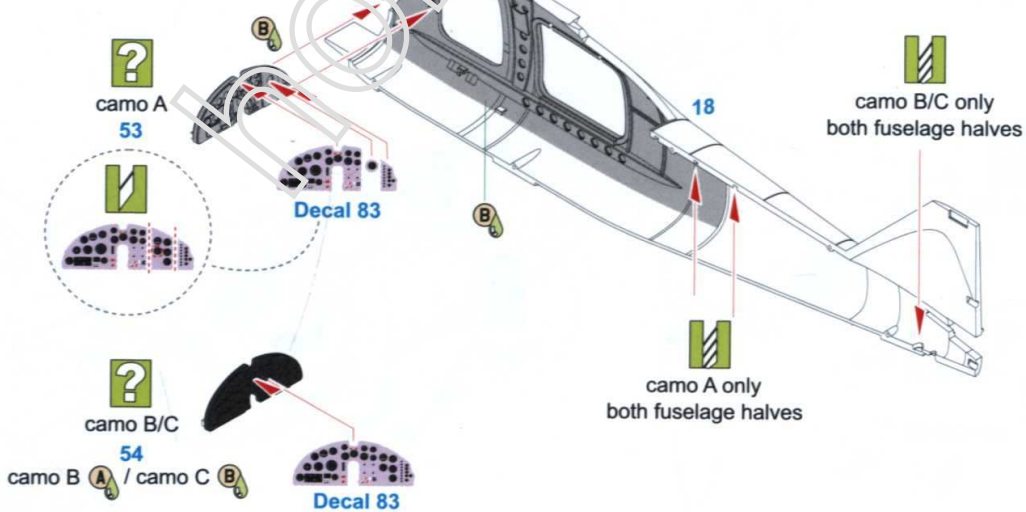

4

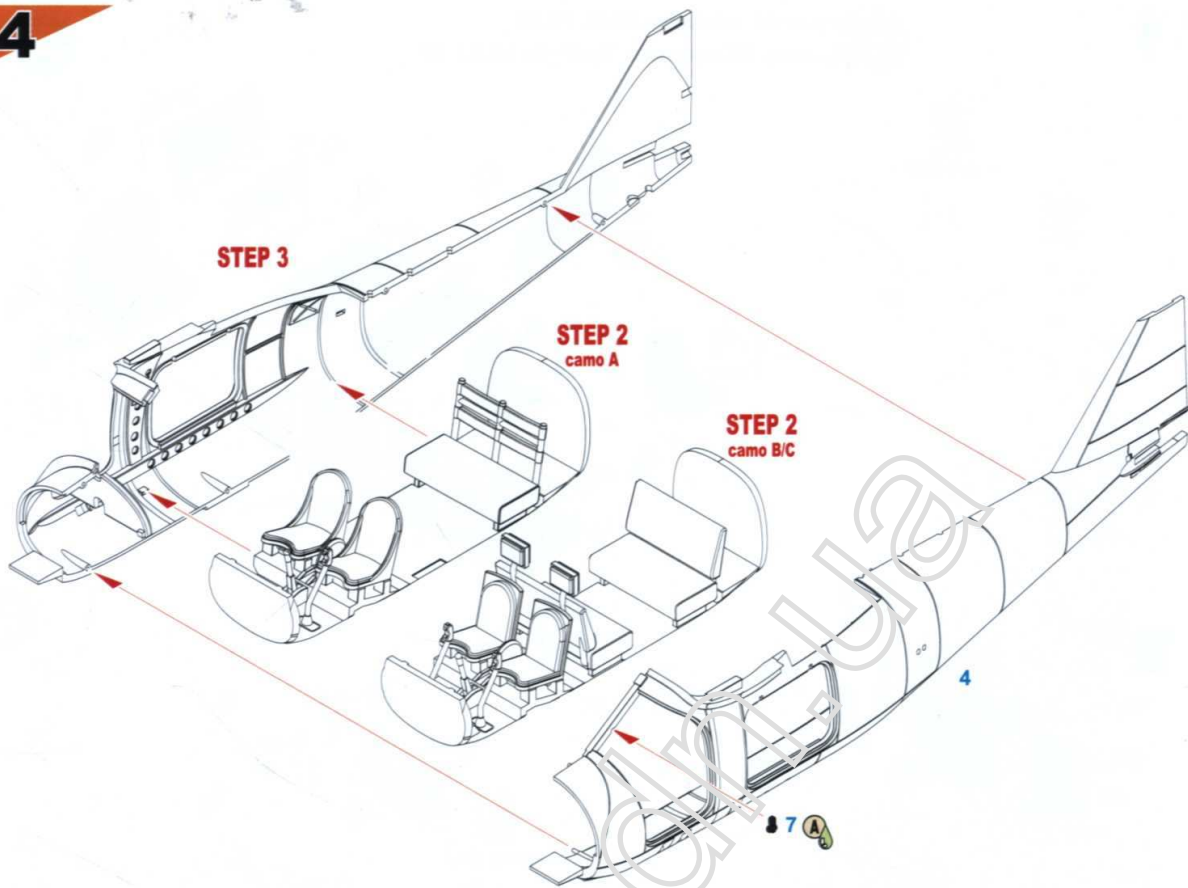

5



6

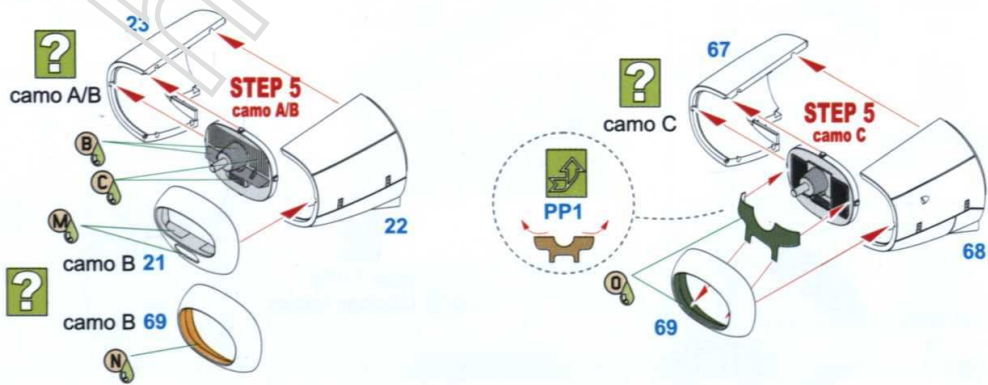

7

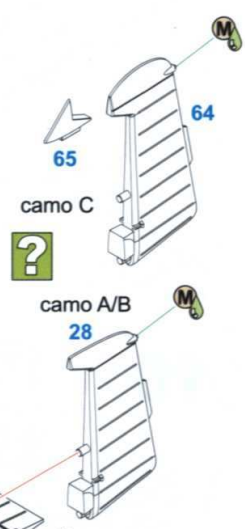
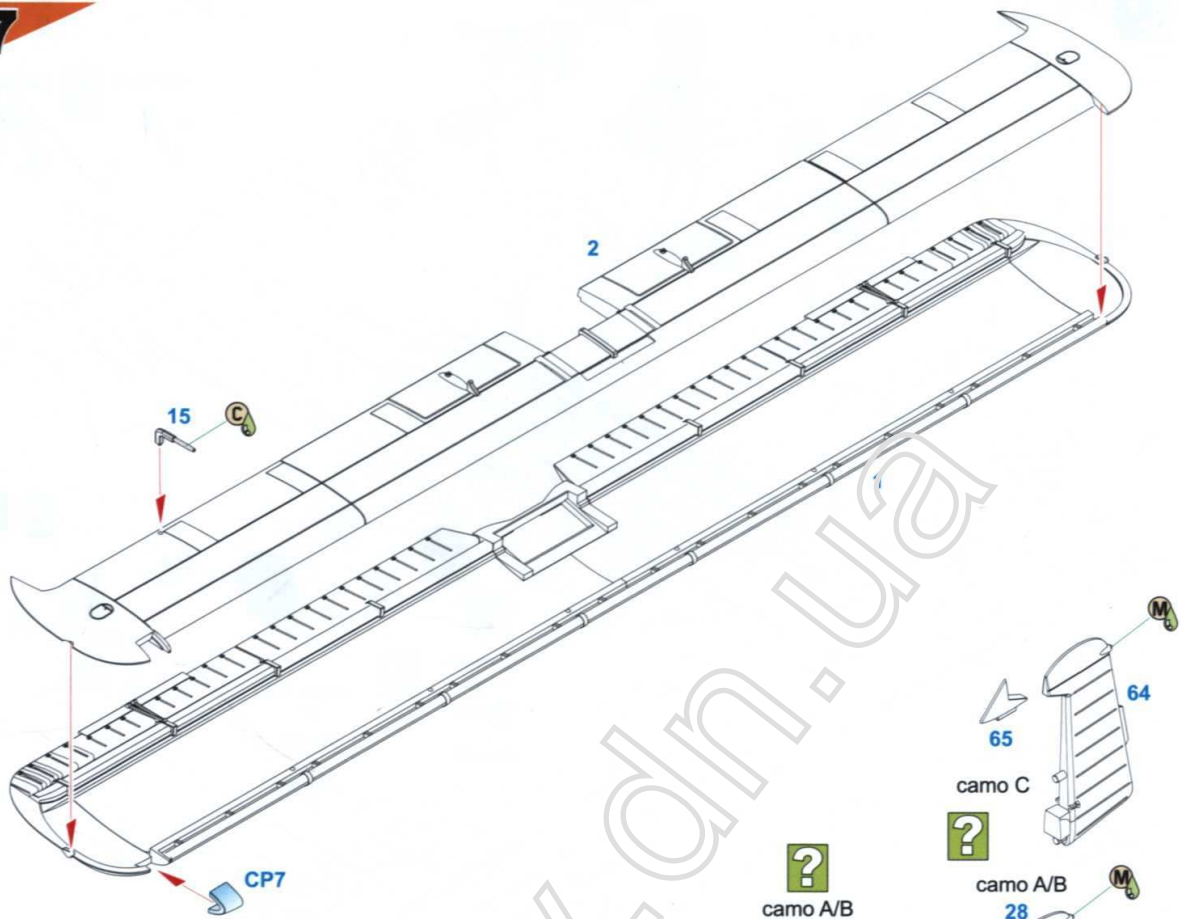

8

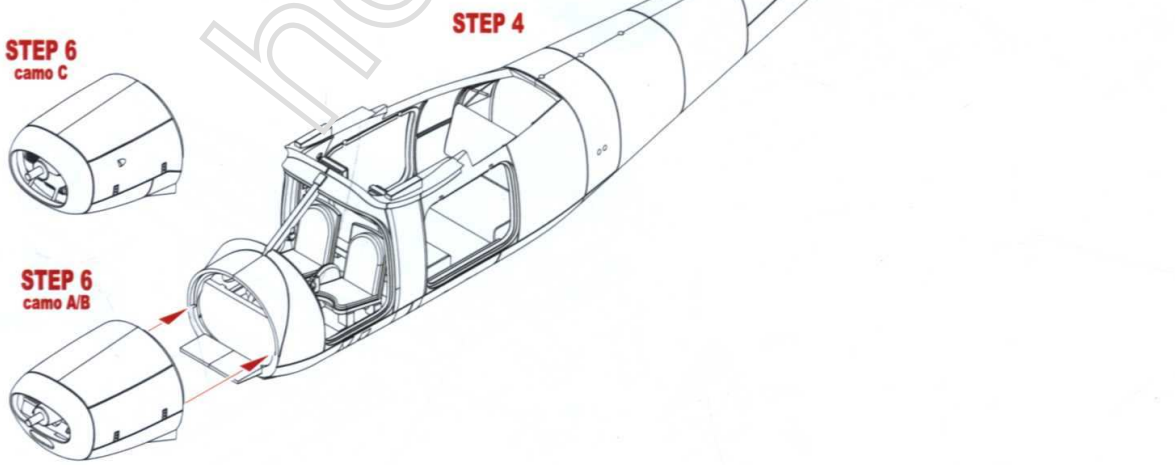

# 9

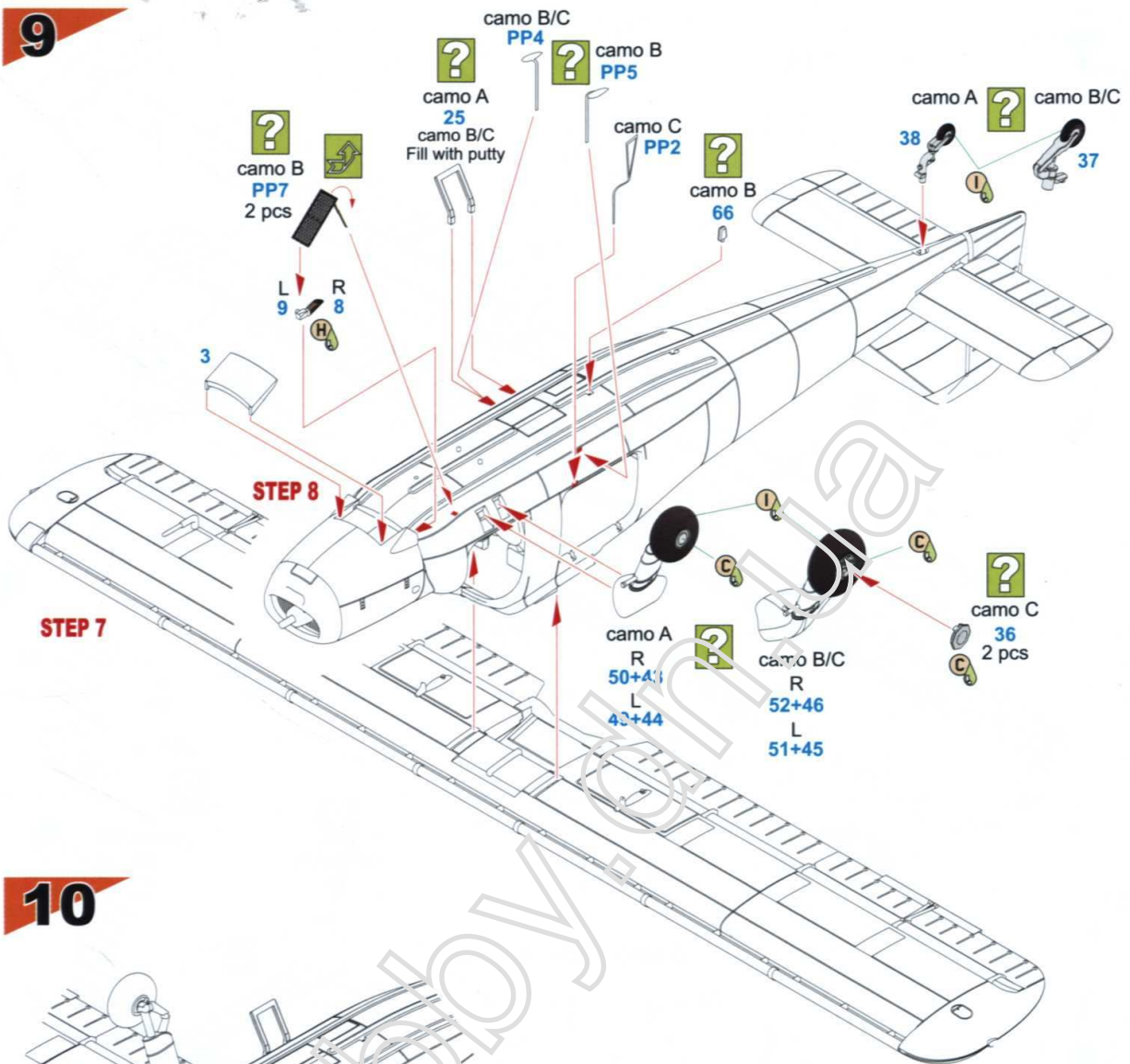

# 10

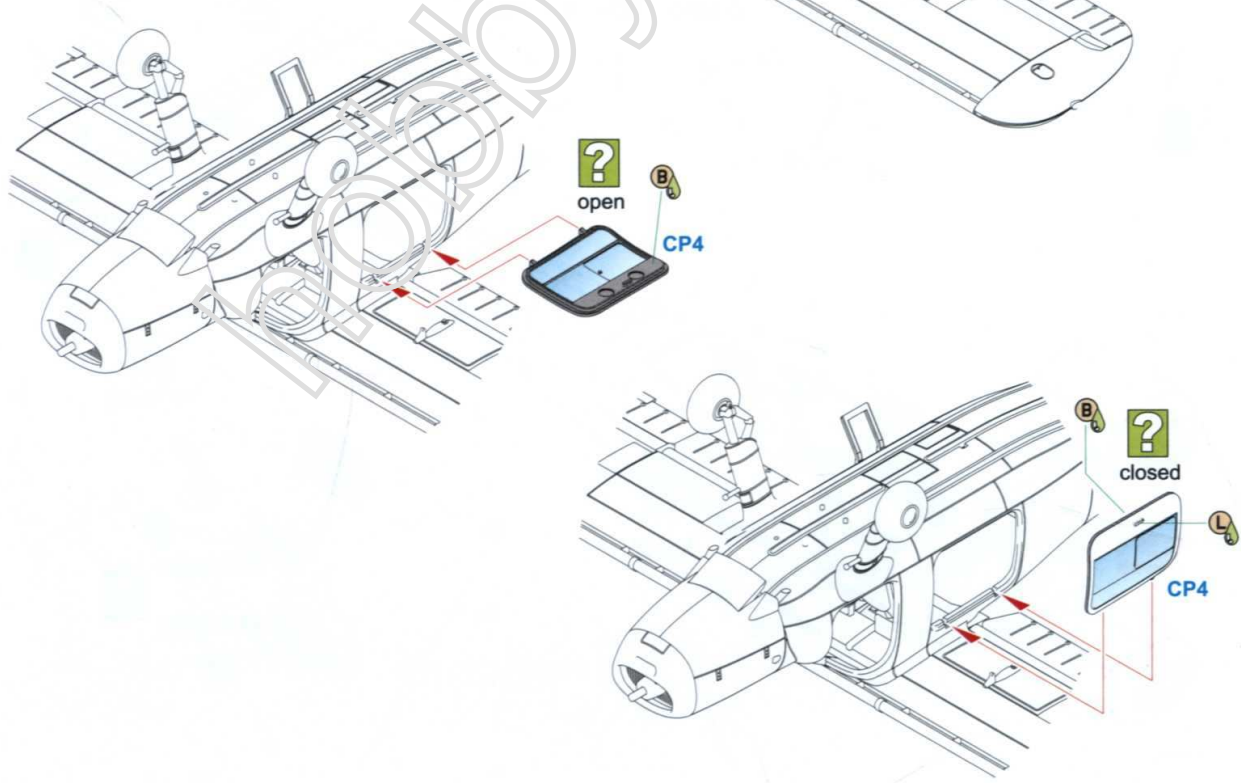

11

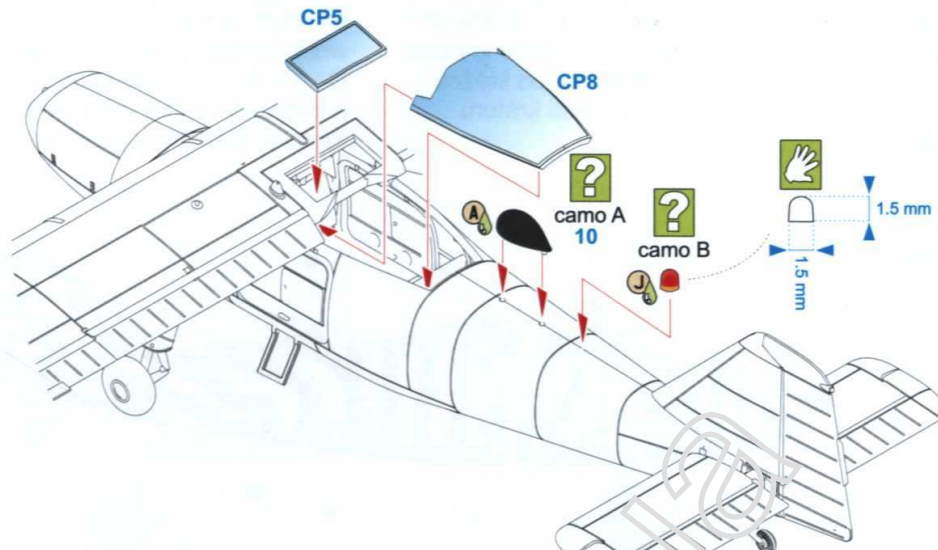

12

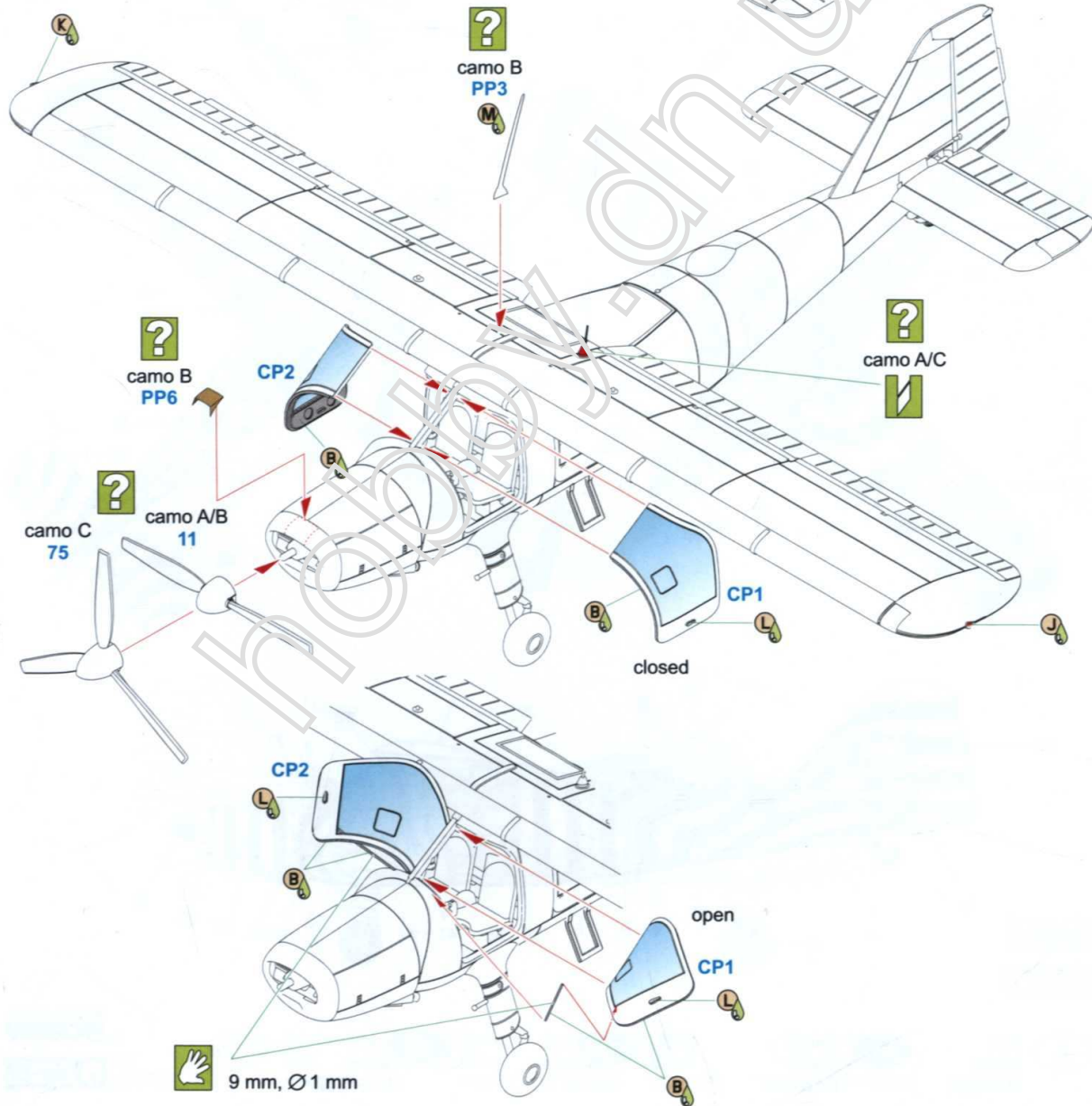

Dornier Do 27B-2, D-ENTE, Tanzania 1958–59.  
 Stroj v zebří m zbarvení používal německý  
 přírodovědec a filmař Michael Grzimek při natáčení  
 přírodovědných filmů. 10. ledna 1959 v tomto letounu  
 zahynul, když letoun ztratil ovladatelnost po srážce  
 s orlosupem bradatým a zřítel se v oblasti kráteru  
 Ngorongoro.

Dornier Do 27B-2, D-ENTE, Tanzania 1958–59.  
 The zebra-striped machine was flown by Michael  
 Grzimek, a West German zoologist and filmmaker  
 while he was making nature documentary films.  
 On 10 January 1959, the plane collided with  
 a bearded vulture over the Ngorongoro crater,  
 the pilot lost control and was killed in the crash.

## CAM. A



**A** Bílá  
 White  
 H11/C62

**B** Černá  
 Black  
 H12/C33

**C** Hliníková  
 Aluminium  
 H8/C8

**D** Žlutá  
 Yellow  
 H329/C329

Special  
**HOBBY**  
 GUNZE  
 SANGYO



Dornier Do 27Q-5, HB-HKA, pojmenovaný Sentimental Journey, soukromý majitel, Švýcarsko, první desetiletí 21. století.

Dornier Do 27Q-5, HB-HKA, dubbed the Sentimental Journey, operated by a private owner, Switzerland, the 2000s.

## CAM. B

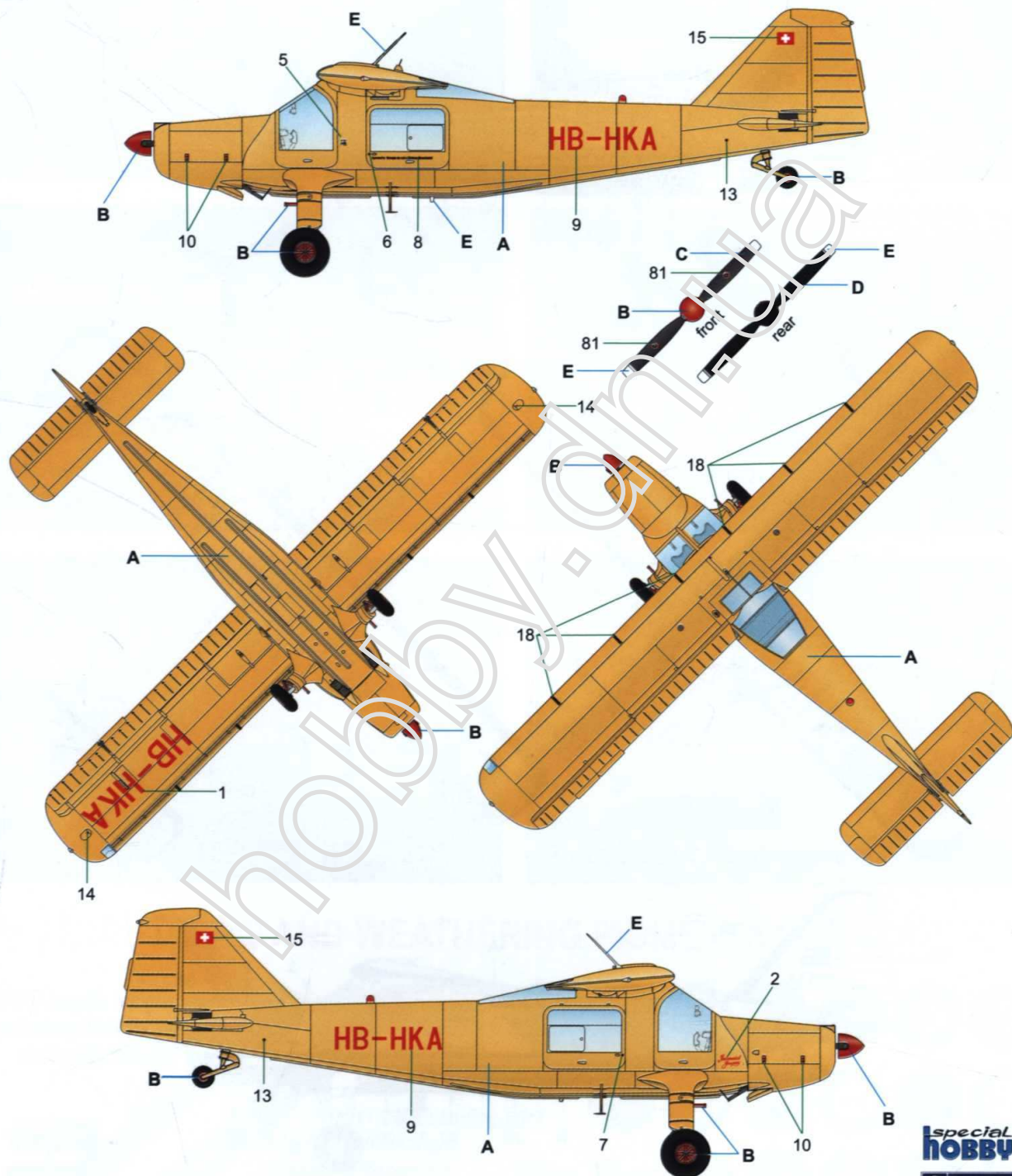

- |                                       |                                  |                                    |                                    |                                   |
|---------------------------------------|----------------------------------|------------------------------------|------------------------------------|-----------------------------------|
| <b>A</b> Žlutá<br>Yellow<br>H329/C329 | <b>B</b> Červená<br>Red<br>H3/C3 | <b>C</b> Šedá<br>Gray<br>H317/C317 | <b>D</b> Černá<br>Black<br>H12/C33 | <b>E</b> Bílá<br>White<br>H11/C62 |
|---------------------------------------|----------------------------------|------------------------------------|------------------------------------|-----------------------------------|

**Special**  
**HOBBY**  
GUNZE  
SANGYO

Dornier Do 27H-2, VH-EXA, Lutheran Mission Aviation Services, Lutheránská misie, Madang, Papua-Nová Guinea, 1962–64. Letoun havaroval po vzletu 3. 9. 1964. Pilot Ray Jaensch zahynul, jeden cestující byl vážně zraněn a další tři vyvázli bez zranění.

Dornier Do 27H-2, VH-EXA, Lutheran Mission Aviation Services, Madang, Papua-New Guinea, 1962–64. On 3 September 1964, the plane crashed after the takeoff, its pilot Ray Jensch was killed, one passenger seriously injured and three others escaped without injury.

## CAM. C

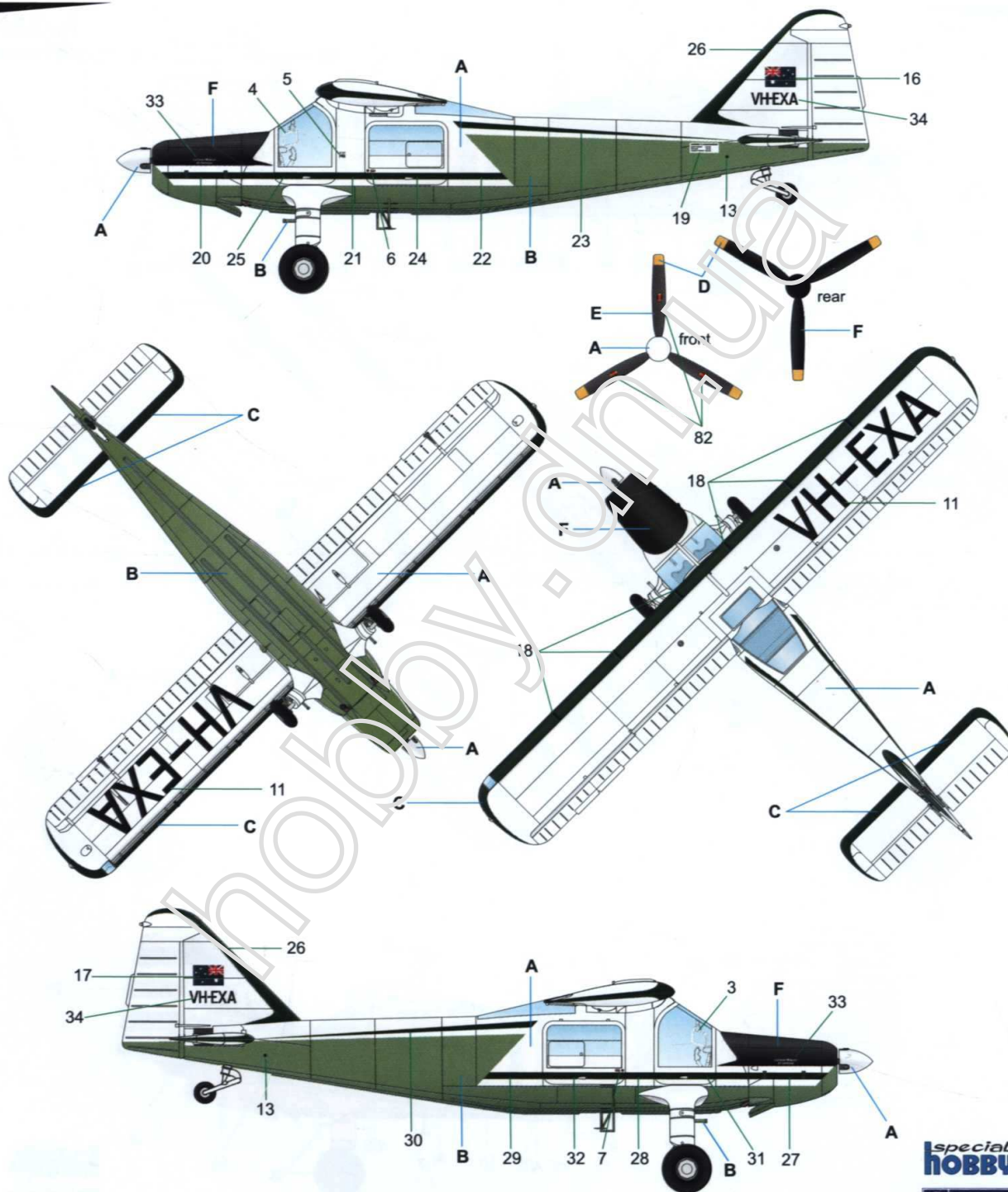

- |                                   |  |   |                                       |                                    |                                    |
|-----------------------------------|--|---|---------------------------------------|------------------------------------|------------------------------------|
| <b>A</b> Bílá<br>White<br>H11/C62 | <b>B</b> Citrónově zelená<br>Lime Green<br>H50 | <b>C</b> Tmavě zelená<br>Dark Green<br>H303/C303<br>FS34102 | <b>D</b> Žlutá<br>Yellow<br>H329/C329 | <b>E</b> Šedá<br>Gray<br>H317/C317 | <b>F</b> Černá<br>Black<br>H12/C33 |
|-----------------------------------|--|---|---------------------------------------|------------------------------------|------------------------------------|

# ATTRACTIVE 1/72 SCALE MODELS OFFERED BY **Special HOBBY**

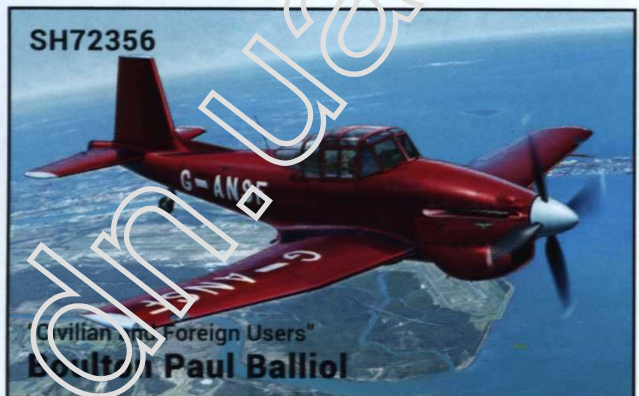

## USE CMK TOOLS AND WEATHERING PIGMENTS FOR YOUR KITS

H1010 handle for our saws  
- priceless tool for resin  
parts adjustment



H1011 CMK sanding stick  
- four different grit  
of sanding papers on  
one sanding stick



All of the above items can be found and ordered  
via our official website and e-shop .....

**WWW.SPECIALHOBBY.EU**  
**WWW.CMKKITS.COM**

# ATTRACTIVE 1/72 SCALE MODELS

MIRAGE F.1 EQ/ED  
SH72386 1/72



CASA C.212-100 Tail Art  
Limited release. Superb artwork decal sheet.  
SH72376 1/72



facebook.com/specialhobby  
[WWW.SPECIALHOBBY.EU](http://WWW.SPECIALHOBBY.EU)  
[WWW.CMKKITS.COM](http://WWW.CMKKITS.COM)

special  
**HOBBY**

