

Bergerpanzer 38(t) was a recovery vehicle based on Hetzer's base, with lower open-top superstructure, manufactured by BMM company in Prague. The plans were approved in September 1944 and called for production of 170 vehicles until the end of 1944. In fact just 101 vehicles were built. To meet the production plans it was decided to convert 64 summer production's Hetzers into armoured recovery vehicles, but it is unknown how many were actually converted. Production was much slower than plans, and total number of about 180 vehicles was finished until the end of the war.

The Bergepanzer was equipped with two-ton folding jib crane used to handle engines and other heavy components. Additionally the recovery vehicle was equipped with five-ton winch of Baumgarten company. The winch was driven by the vehicle's engine through transmission system. At the end a blade was installed at the rear of the hull, but it is again unclear how many vehicles were equipped with it. There were also some development works to install the blade at the front of the vehicle, as seen in the company blueprints, but probably these plans were never realized.

Early Bergehetzer variant was mostly equipped with early type of road wheels and idler wheels, it had different towing eyes, the front armor was thinner than Late variant, its engine cover was early type without two additional small access hatches, with early type of exhaust muffler. The rear support blade was developed later and installed on the Late Bergehetzer variant only.

Kit TM35102 Standard edition (excludes engine compartment, mudguards and skirts moulded in plastic)

Kit TM35103 Limited Bonus Edition (includes engine compartment and additional PE set mudguards, skirts)

Engine assembly (Limited Bonus Edition only)

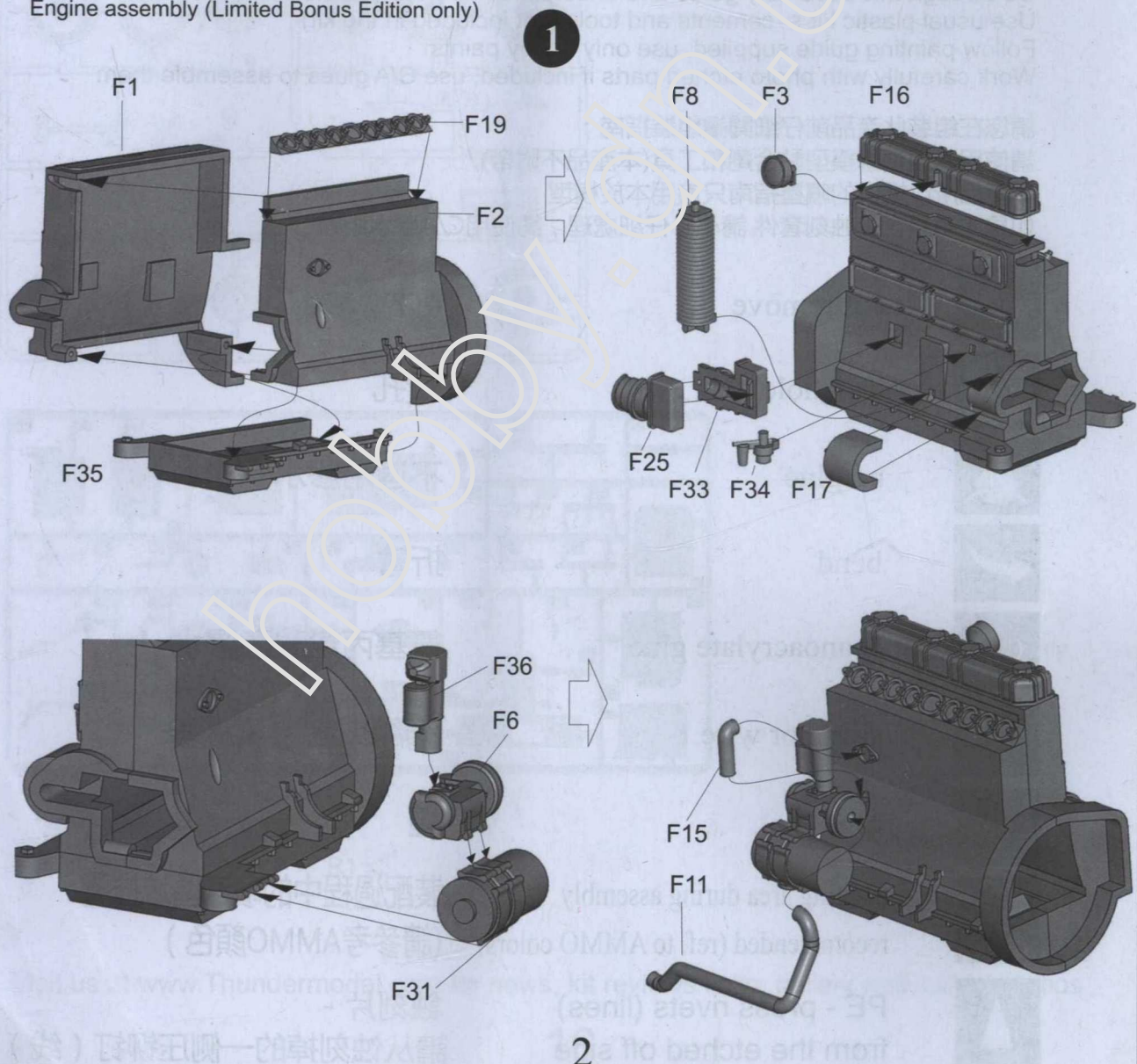

2

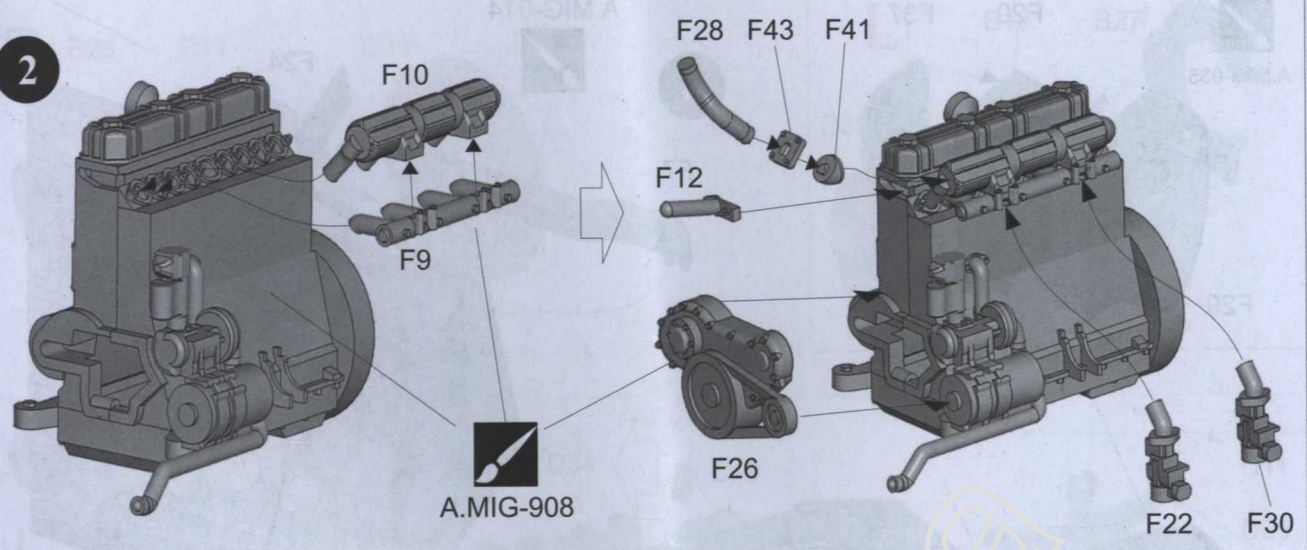

3

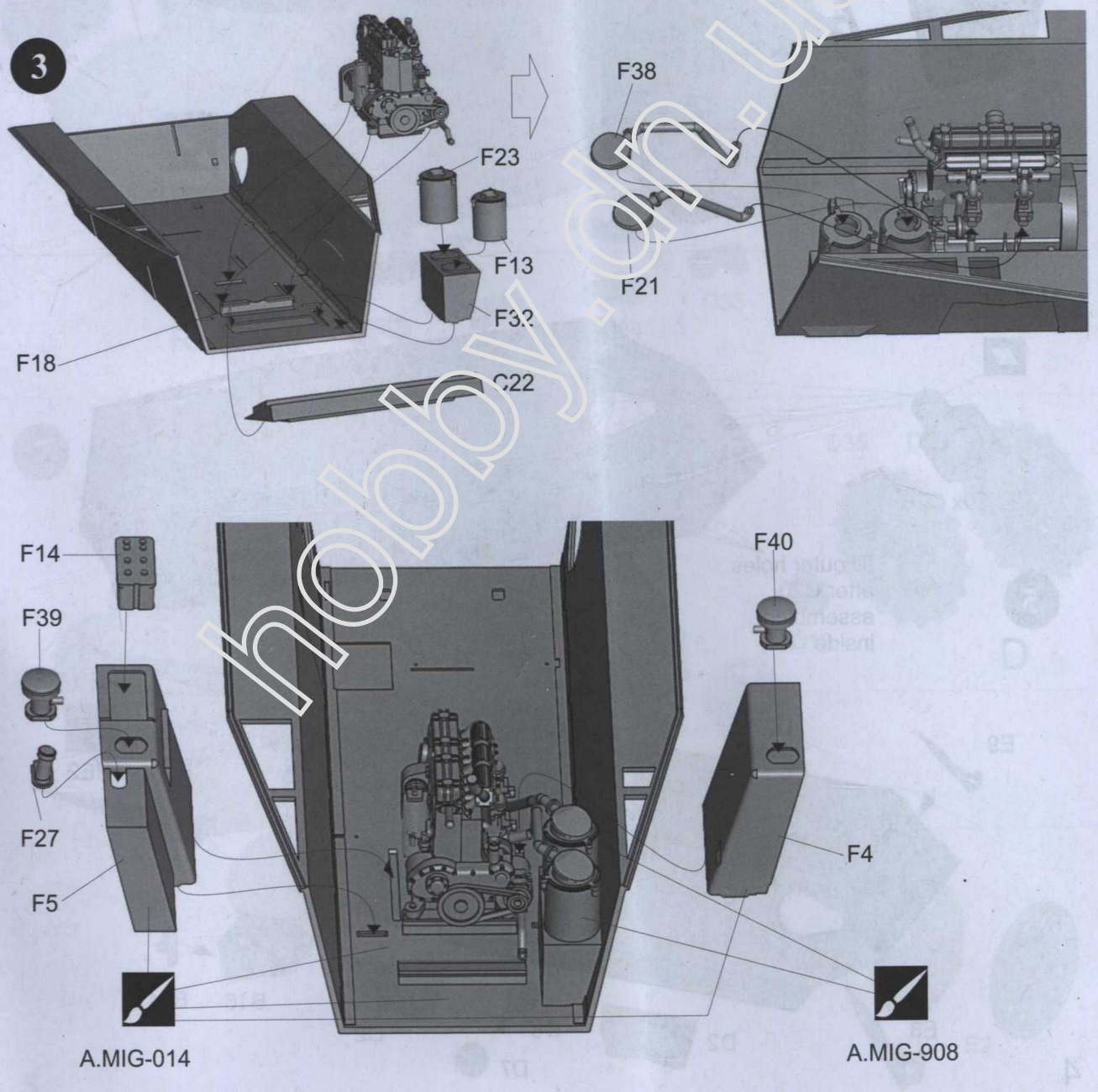



A.MIG-035

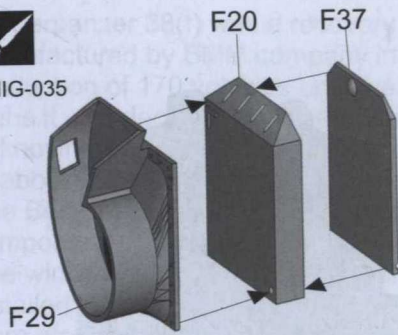

4

A.MIG-014

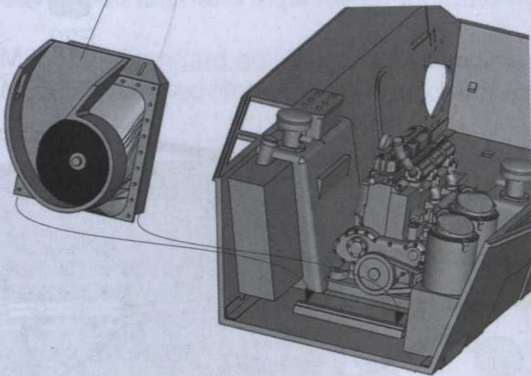
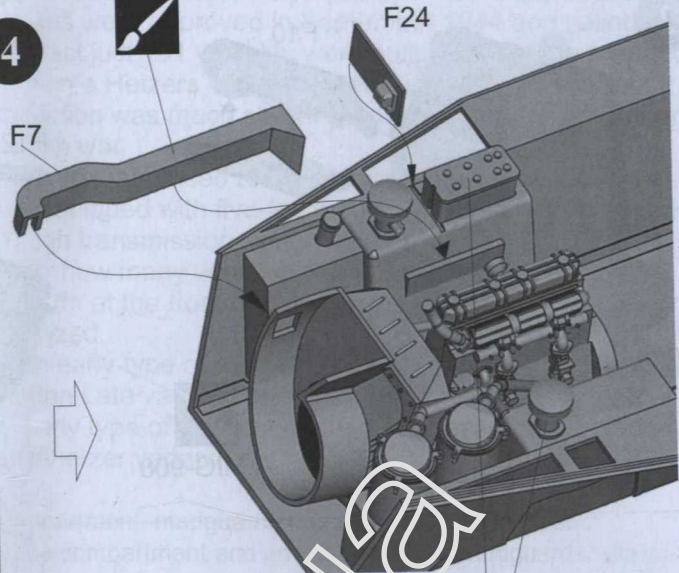

A.MIG-908

Hull assembly



20x C20

5

fill outer holes  
after C20  
assembled  
inside

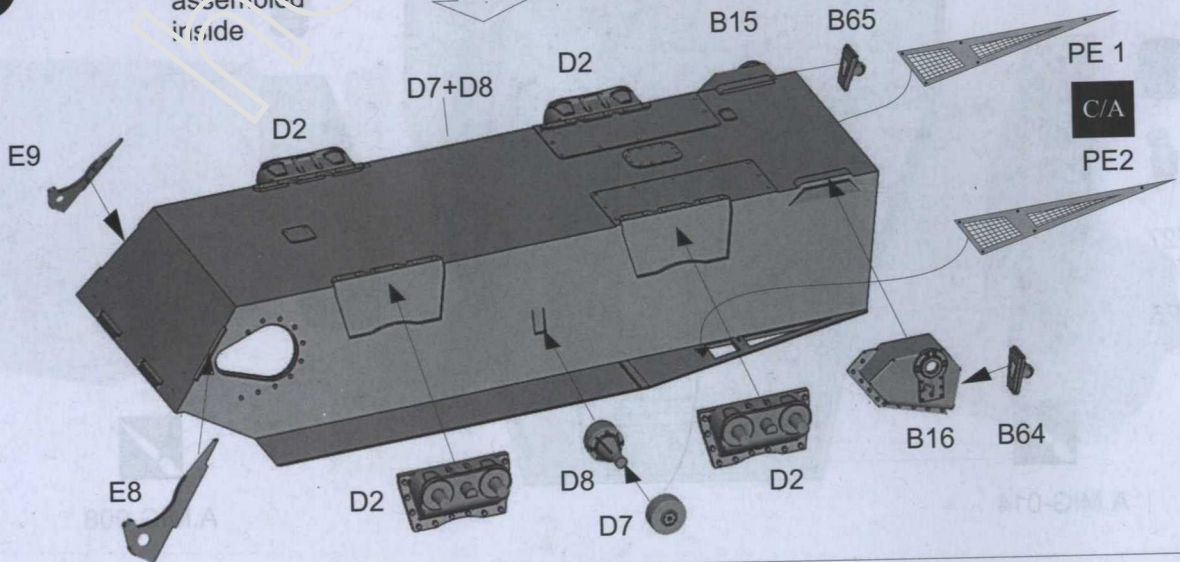

4

R

B28

B14

D39

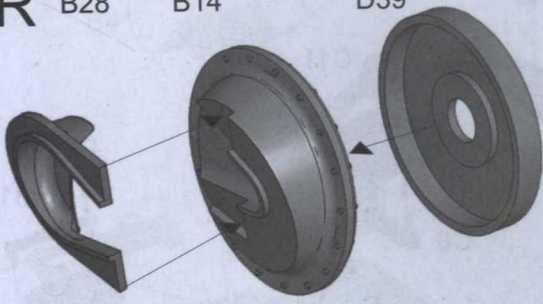

L

B13

B27

D39

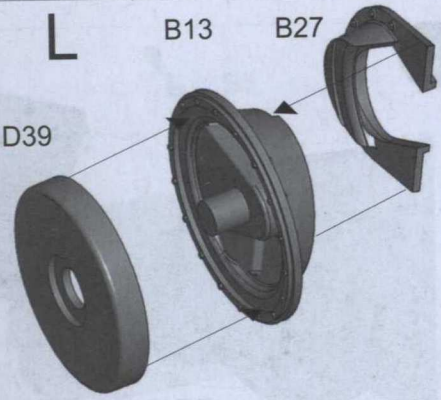

6

F

D33

D34

D19

D33

D34

L

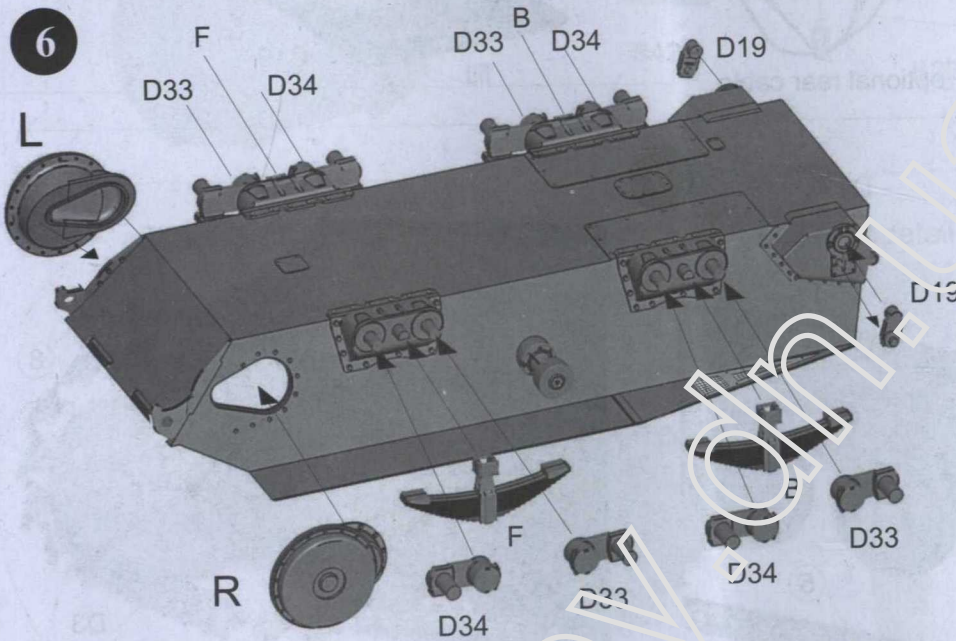

D11

D25

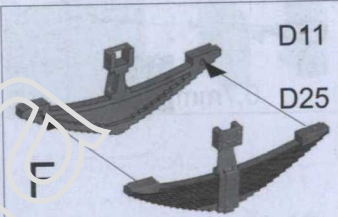

D12

D13

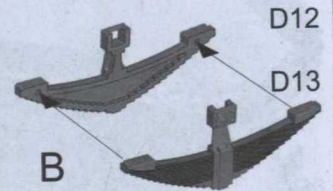

7

E1

E1

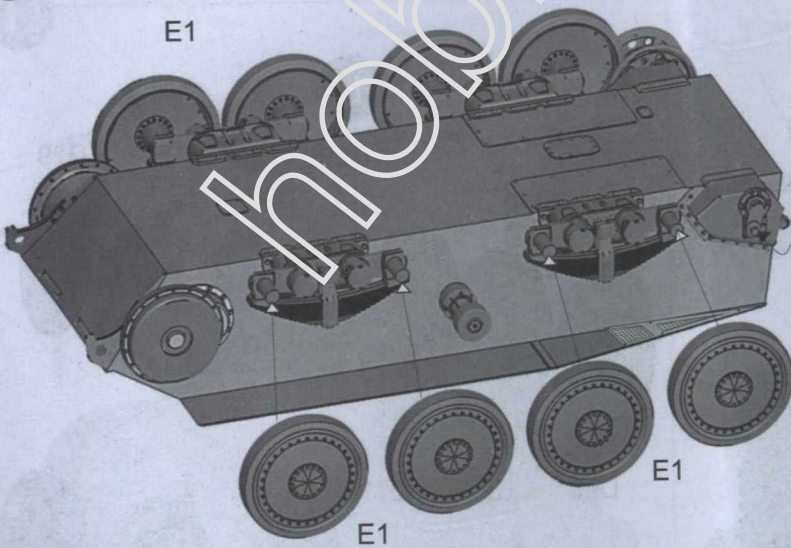

D35

D36

D18

D

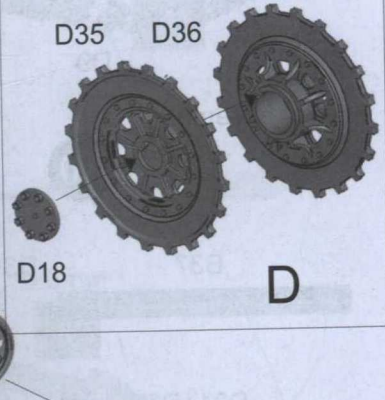

E1

E1

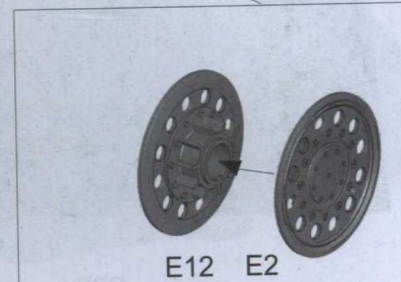

E12 E2

5

8

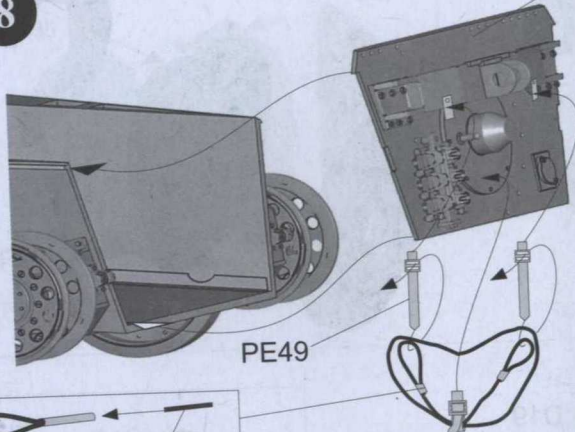

R1  
0,7mm

optional rear cable

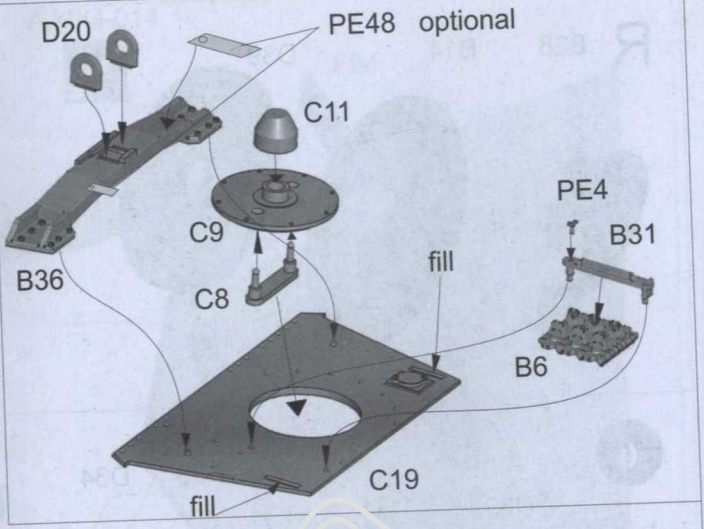

9

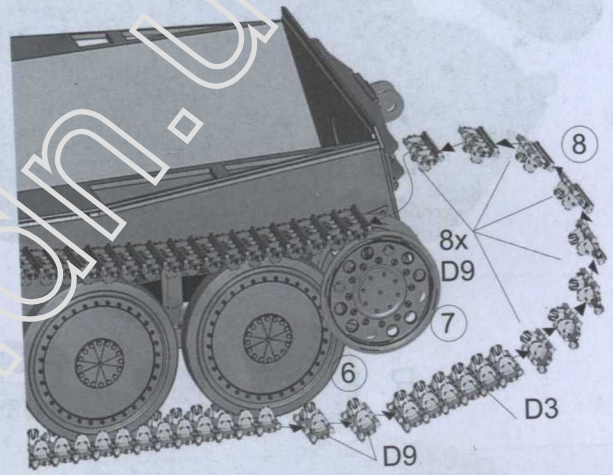
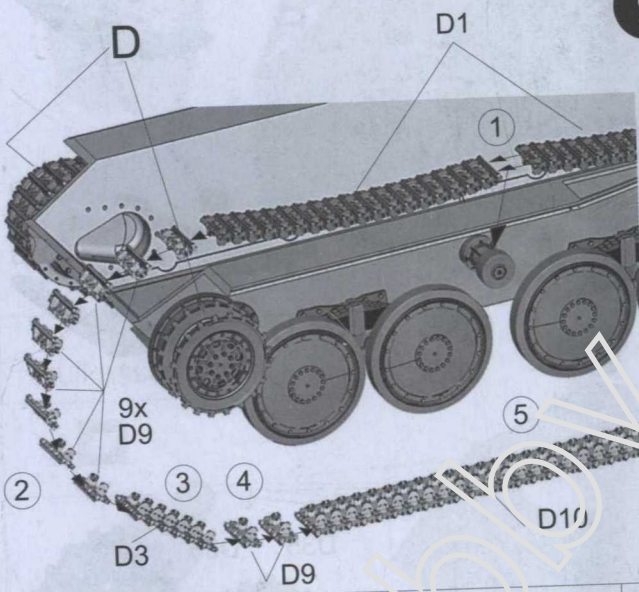

Interior assembly

10

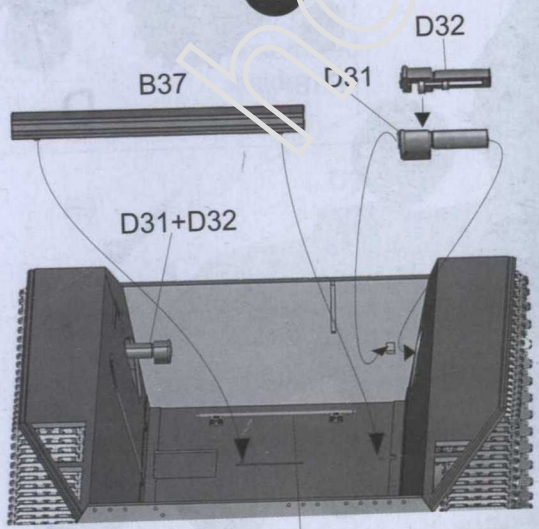

6

11

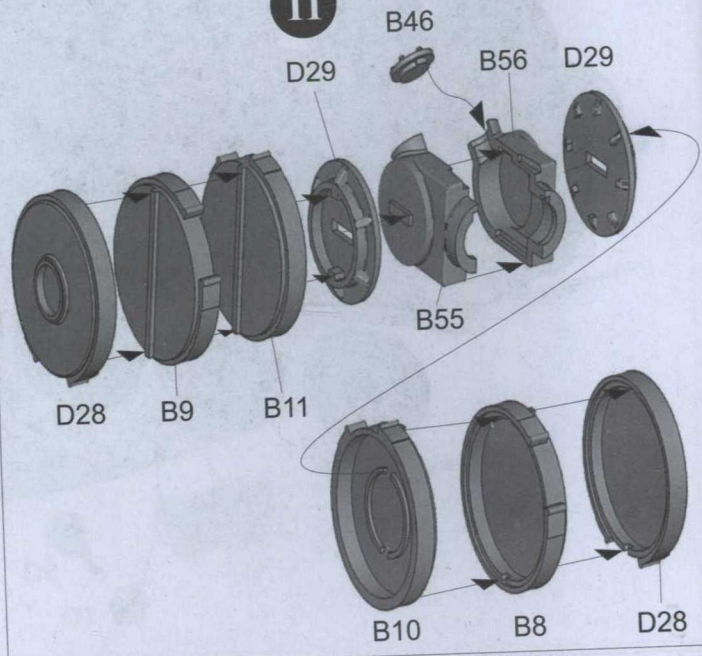

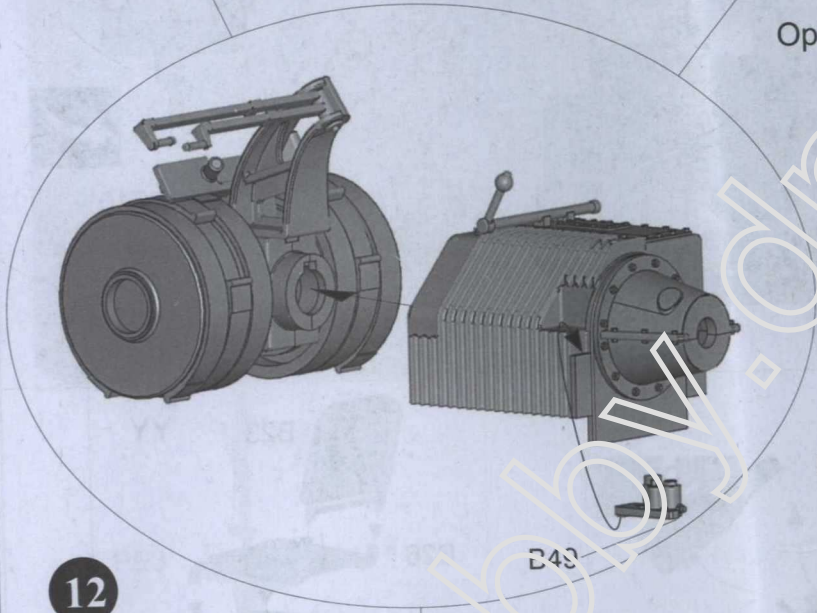
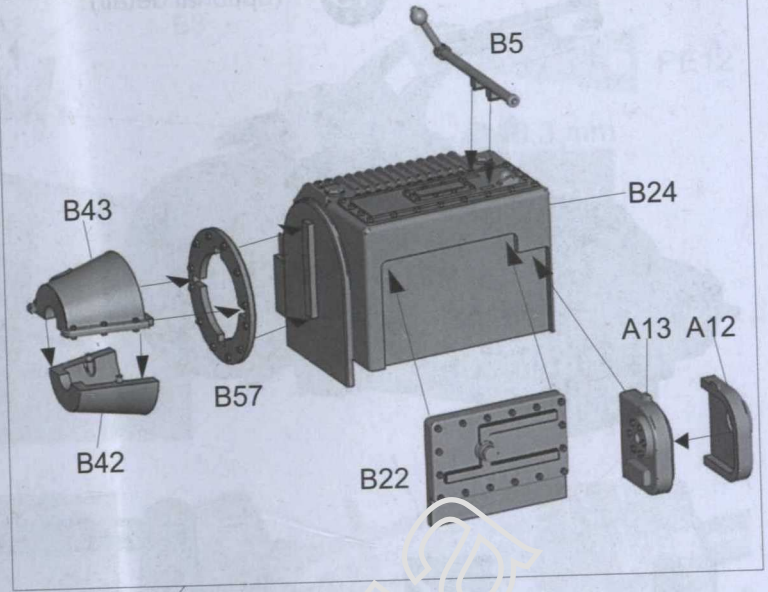
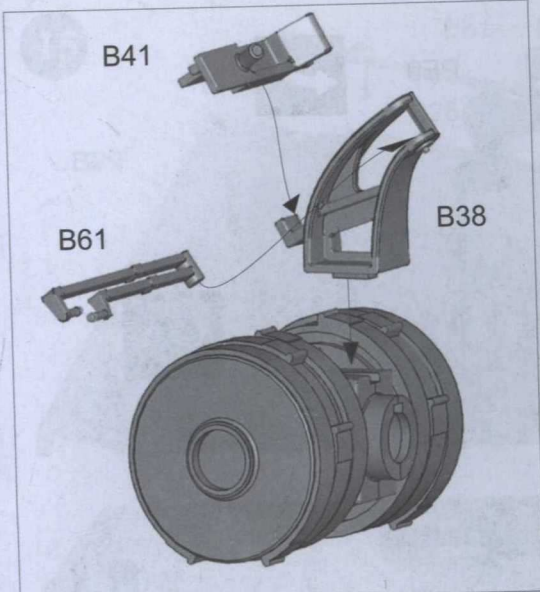

Optional detail - PE 5,6,8,9,10,11,12

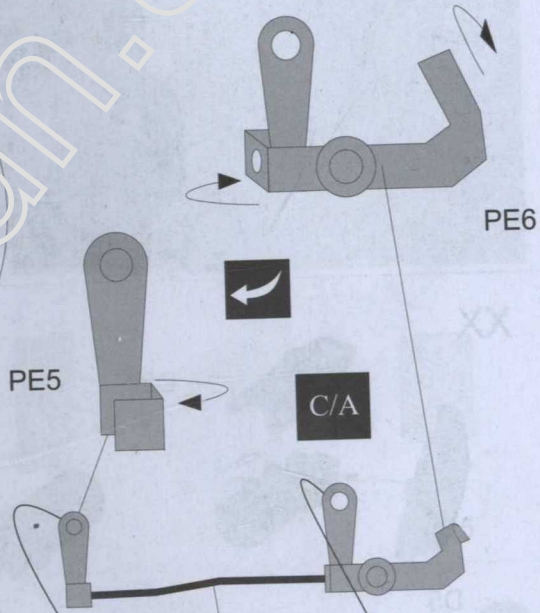

12

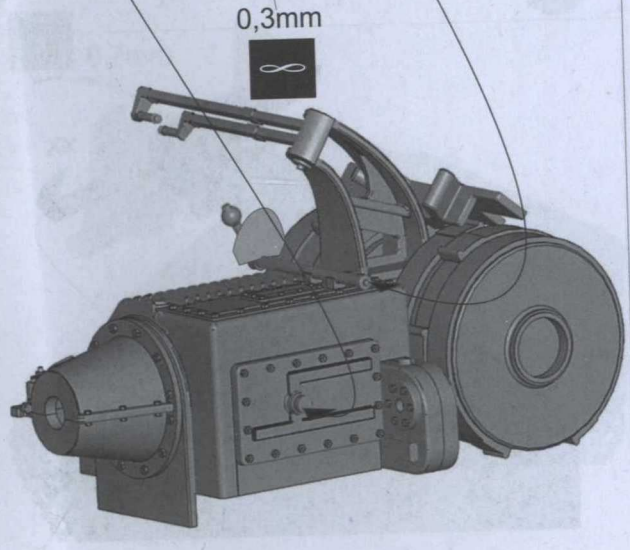
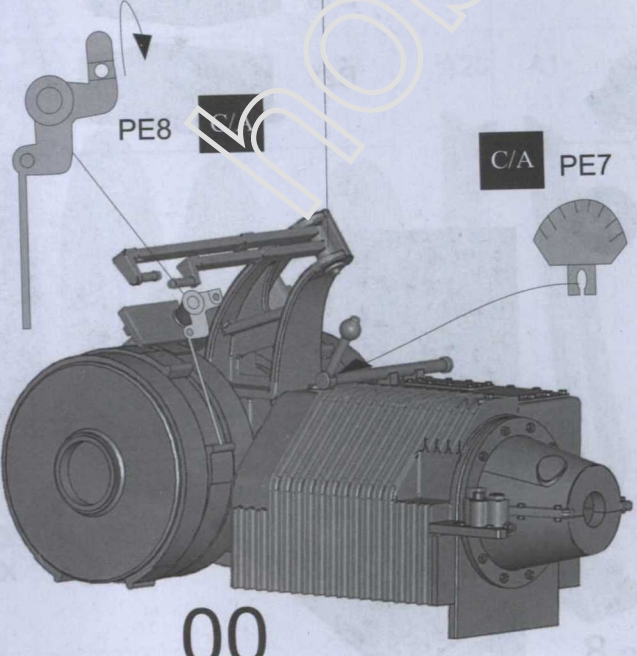

**13** (optional detail)

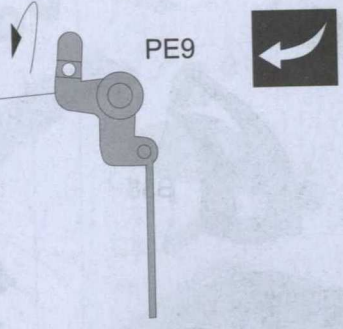
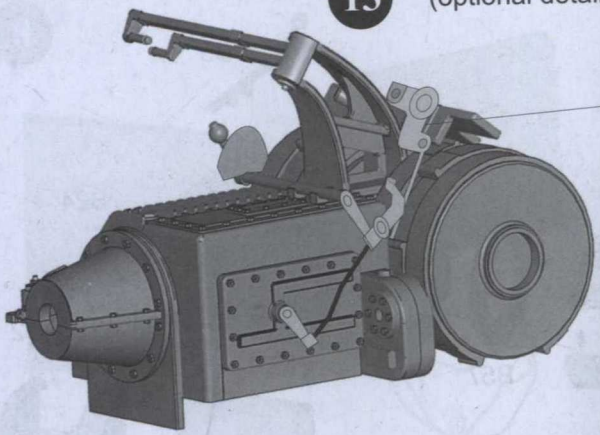

C/A

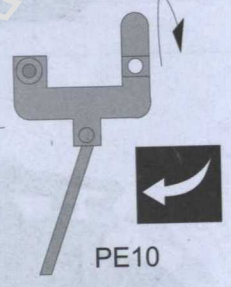
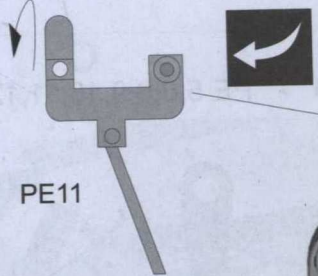

XX

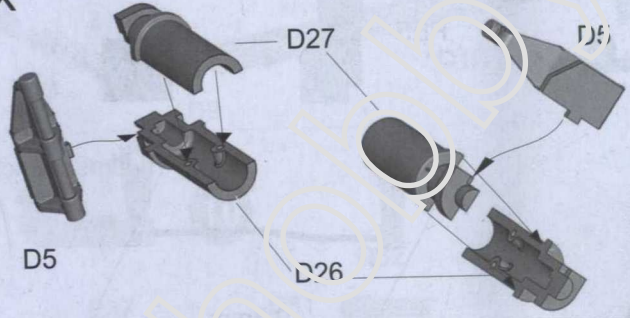

**14**

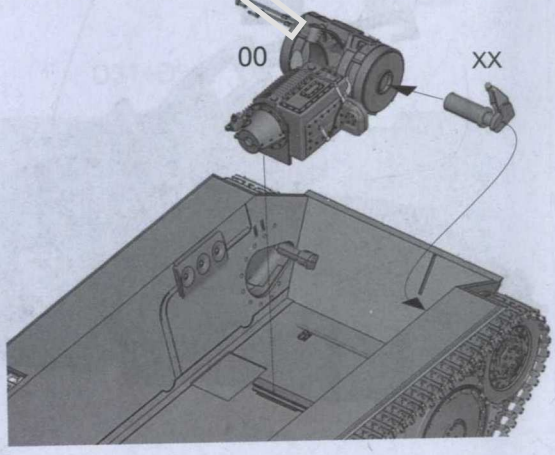

8

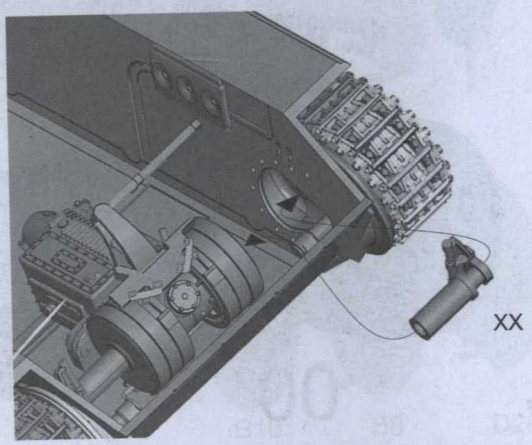

15

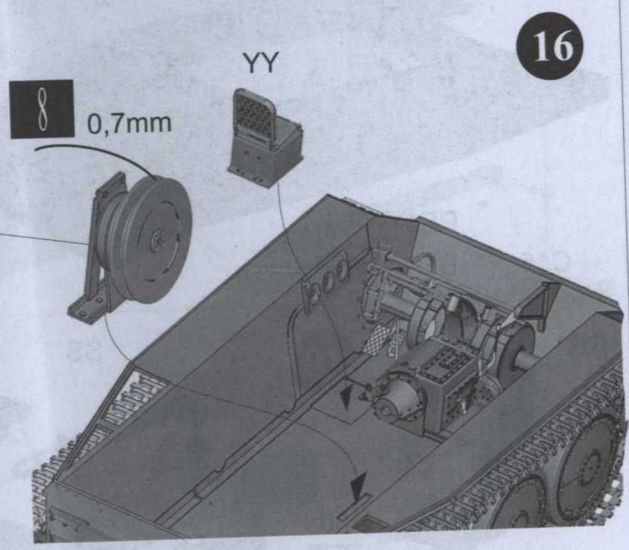
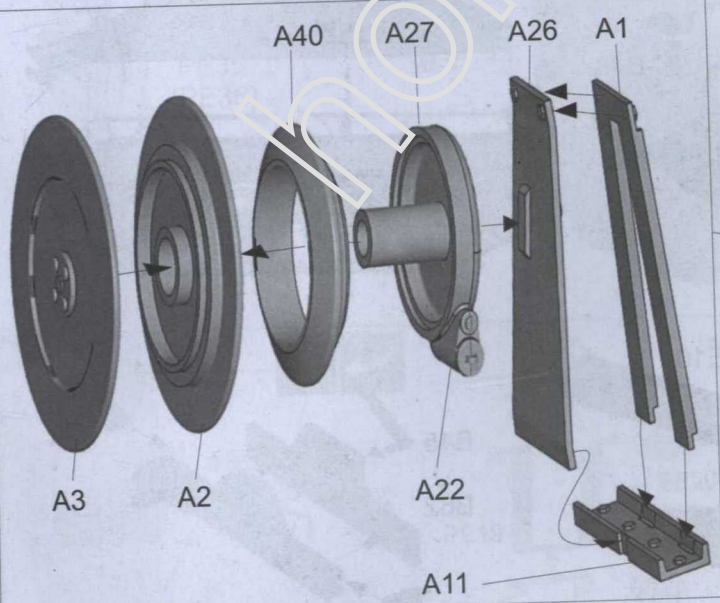
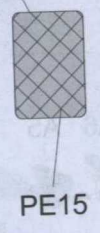
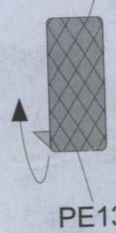
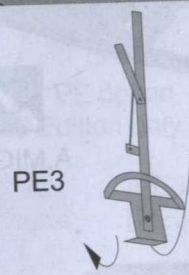
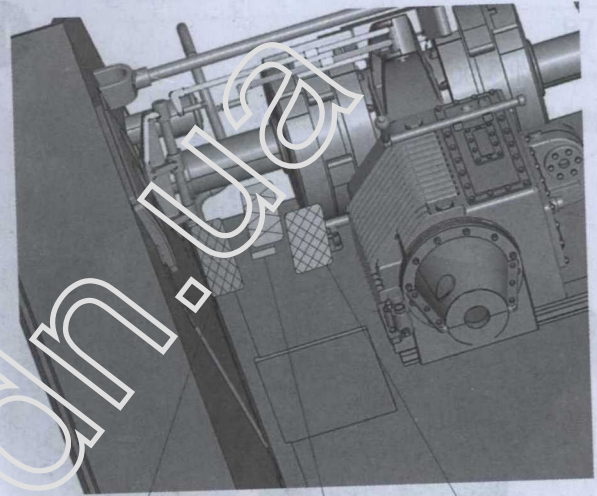
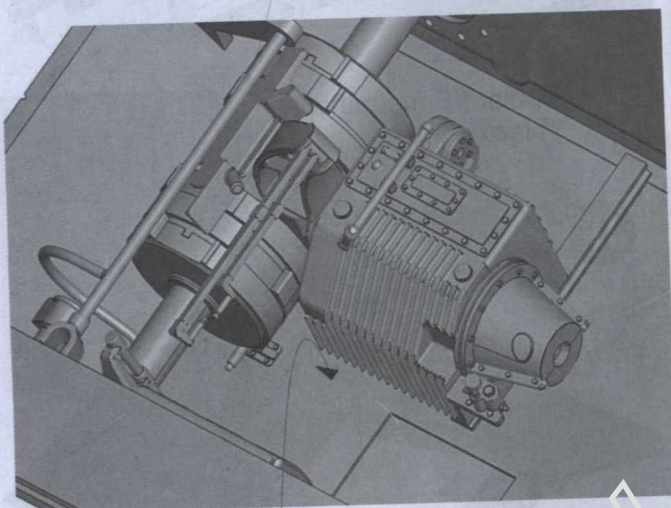
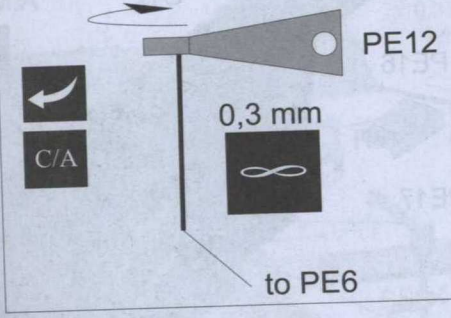
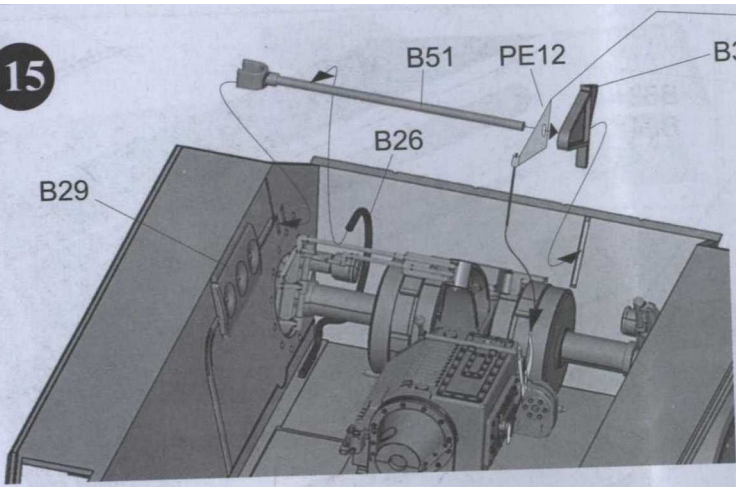

16

9



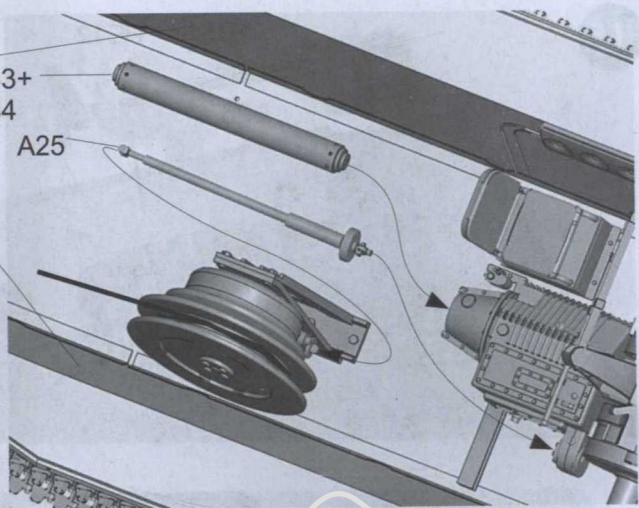
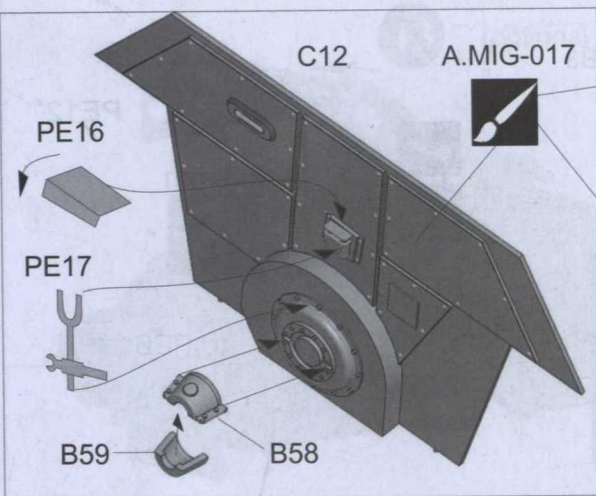

17

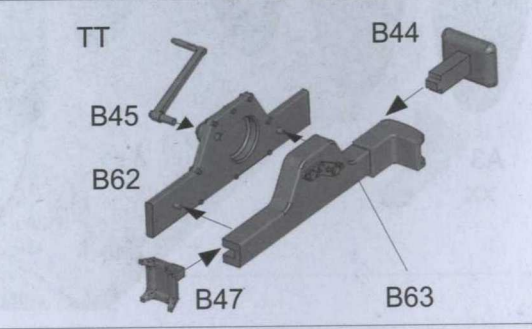
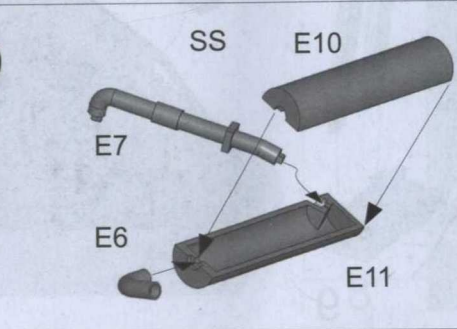
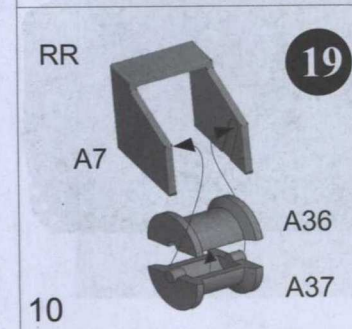
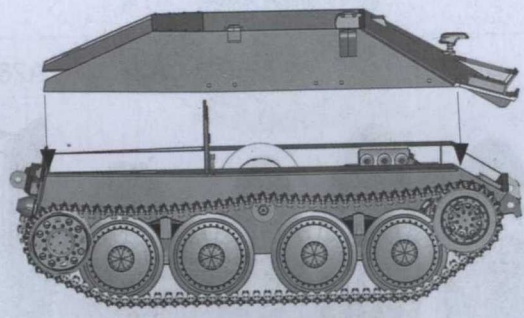
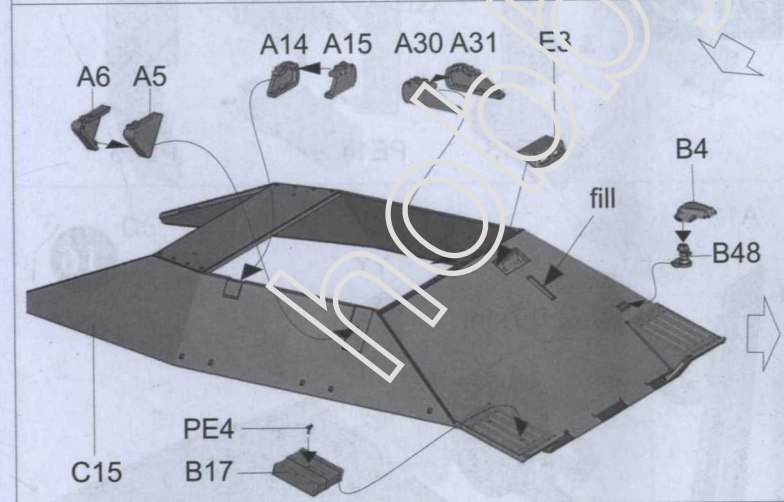
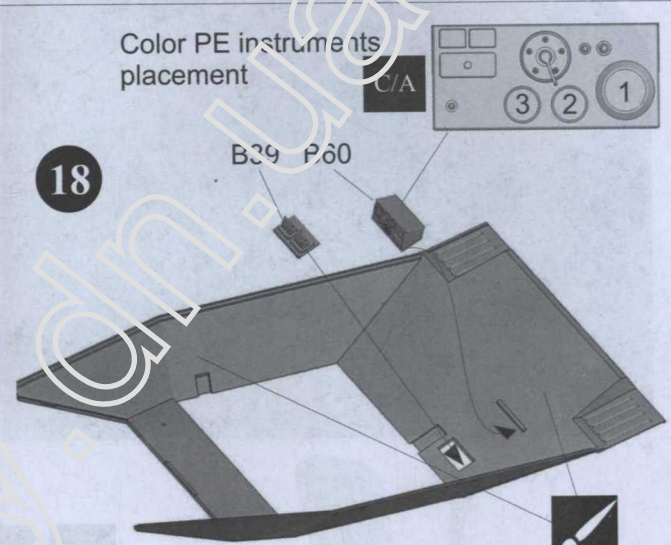
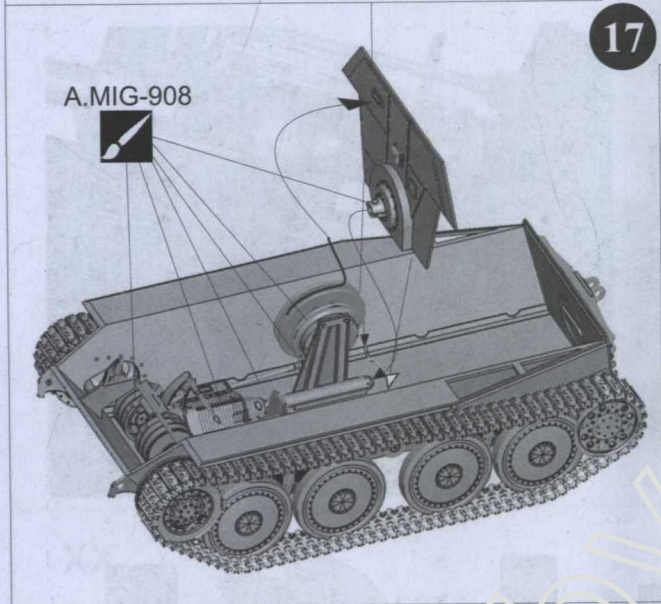

10

20

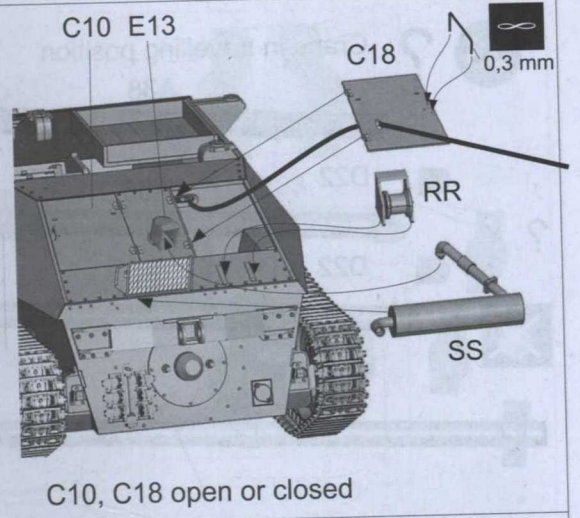
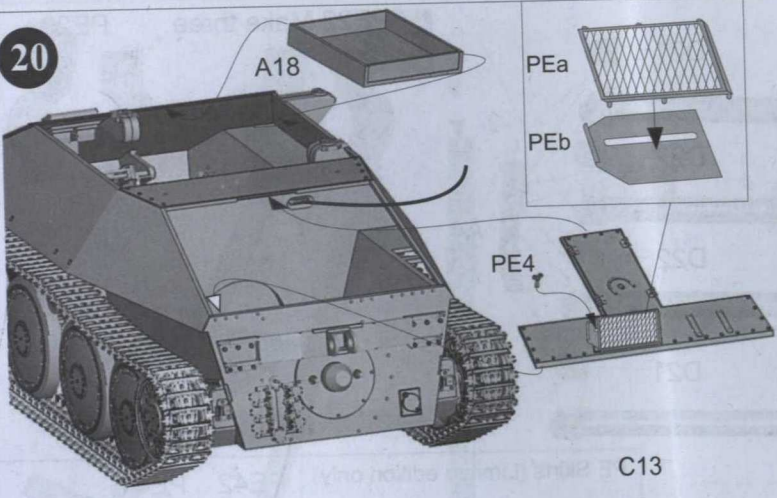

C10, C18 open or closed

21

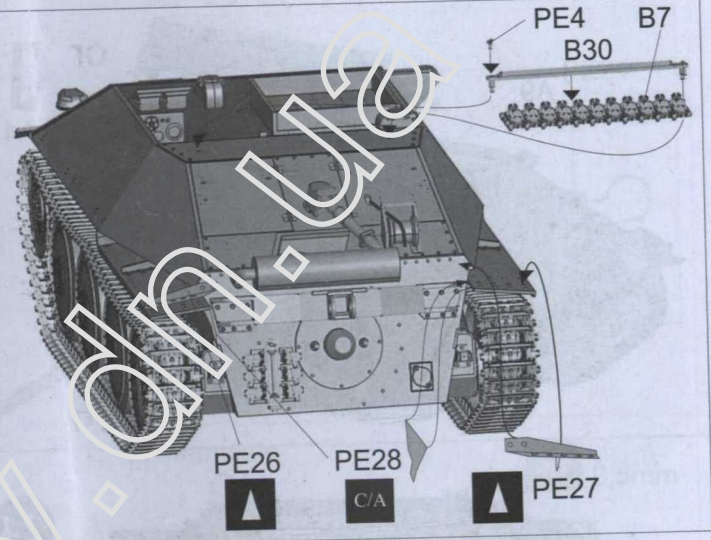
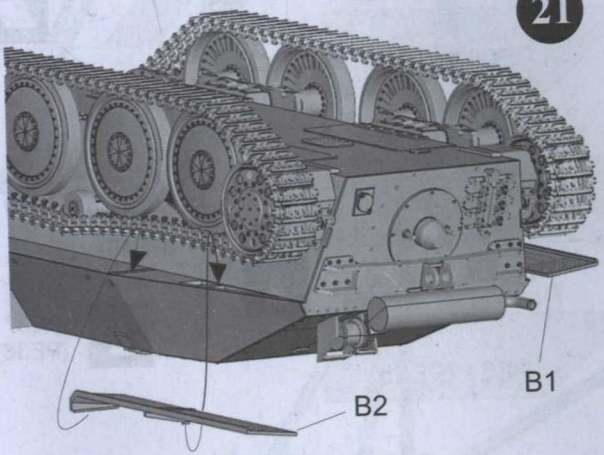

B1, B2 PE option Limited Edition only

22

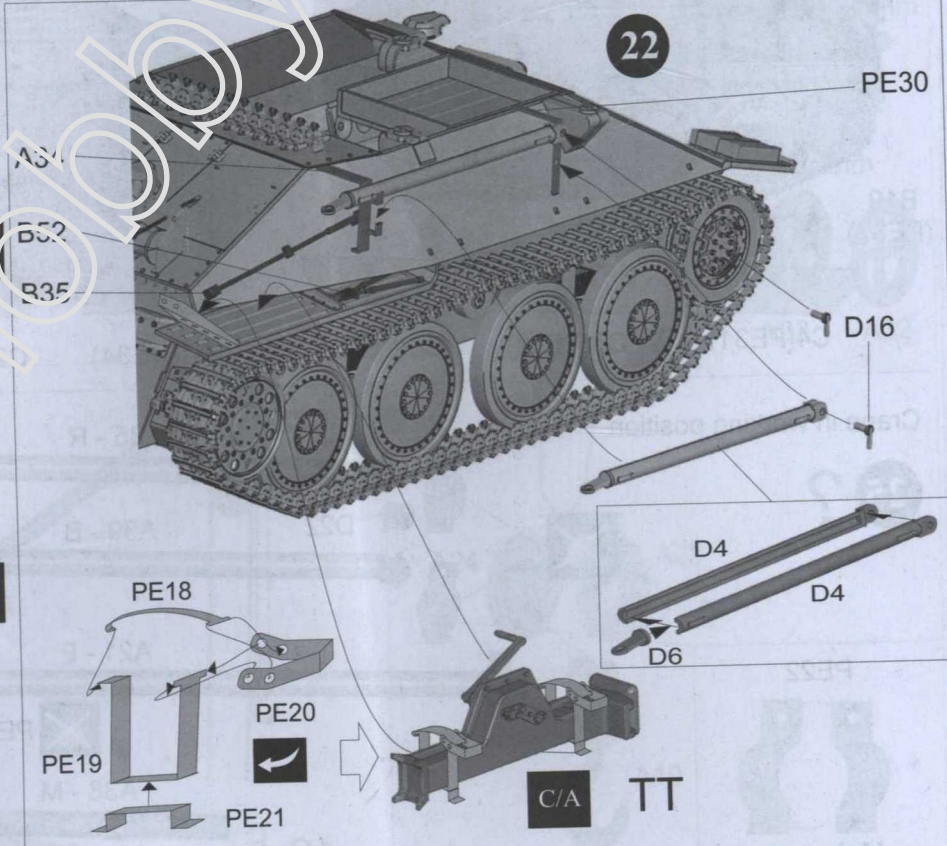
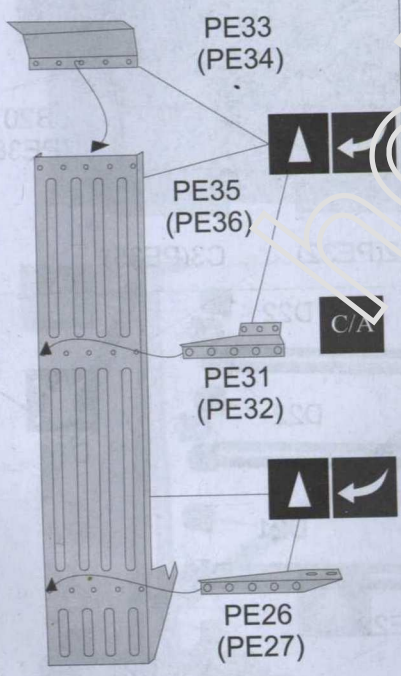

23 ?

Crane in travelling position  
A38

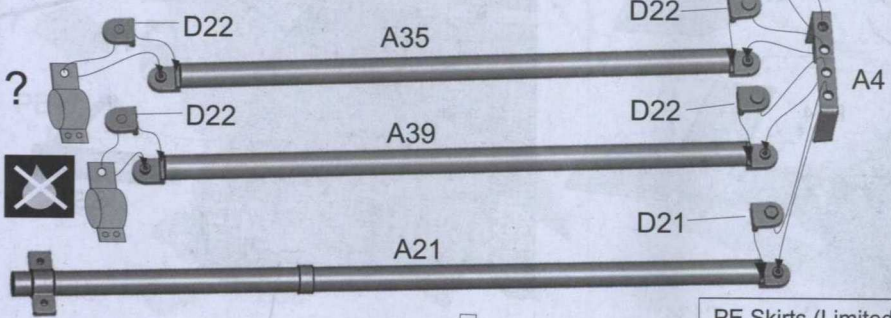

PE22 Make three

PE23

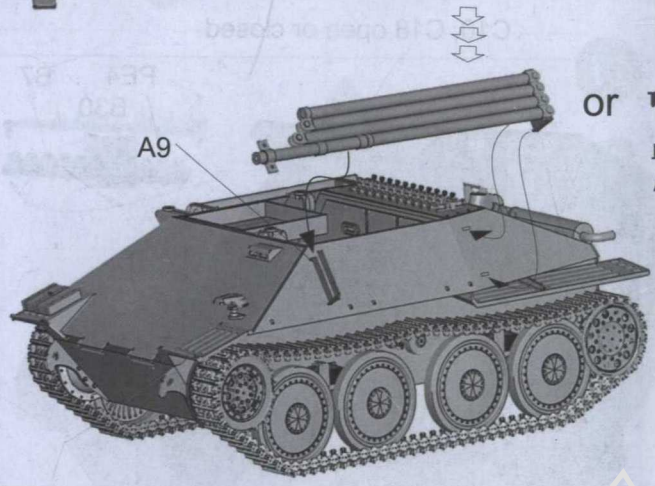
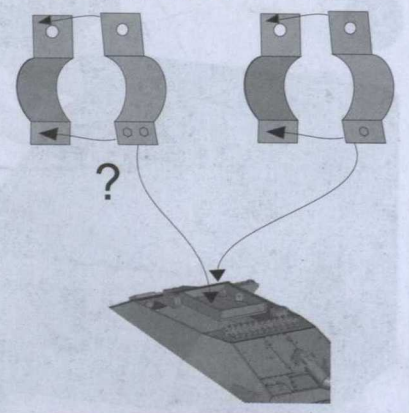

PE Skirts (Limited edition only)

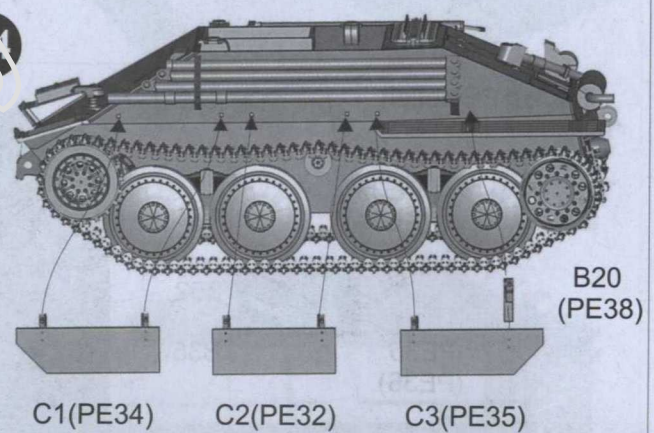
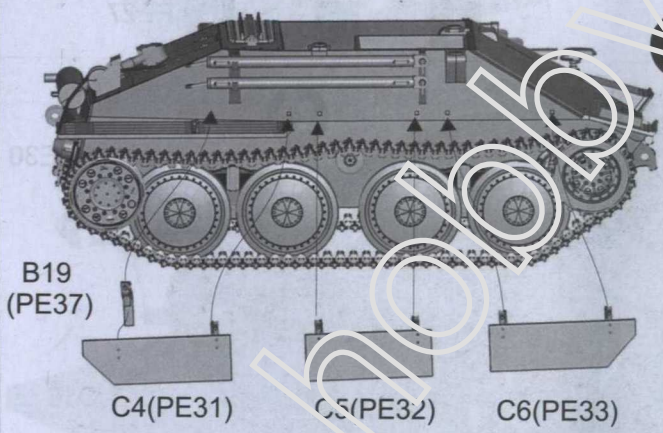
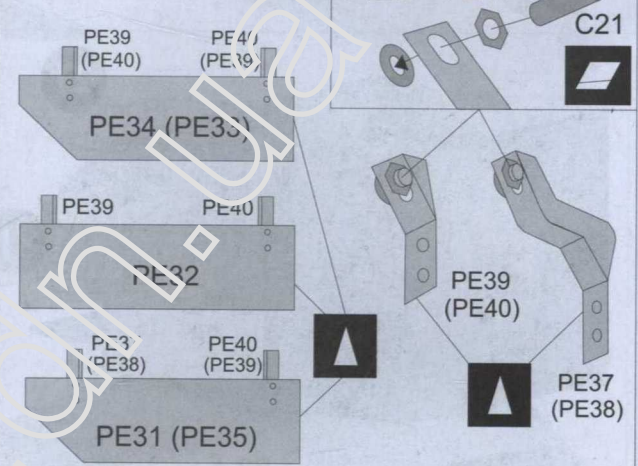

Crane in working position

25 ?

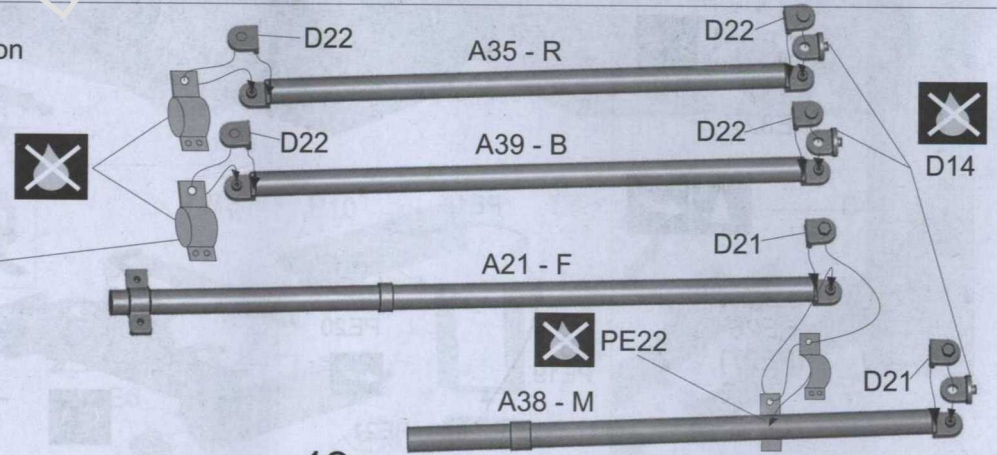

PE22

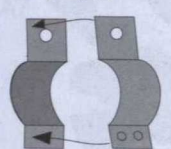

Make two

26

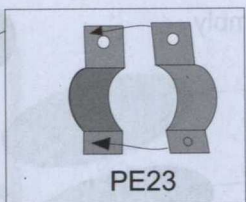
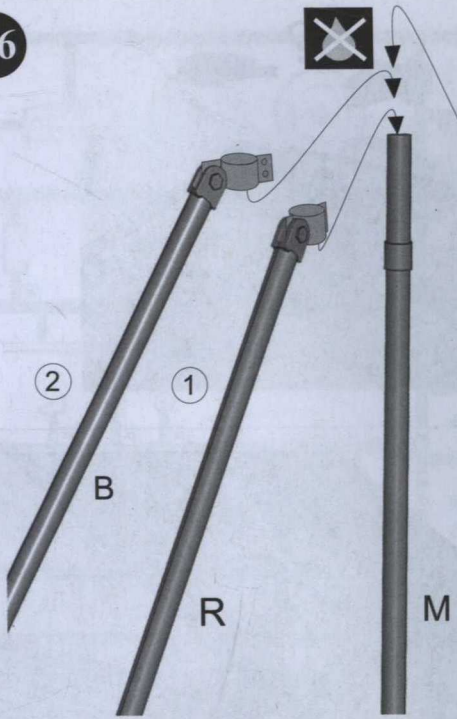

PE23



D15

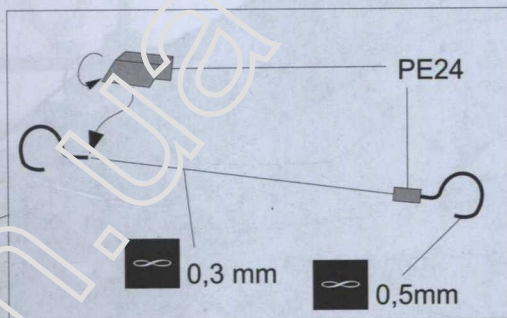

PE24

0,3 mm

0,5mm

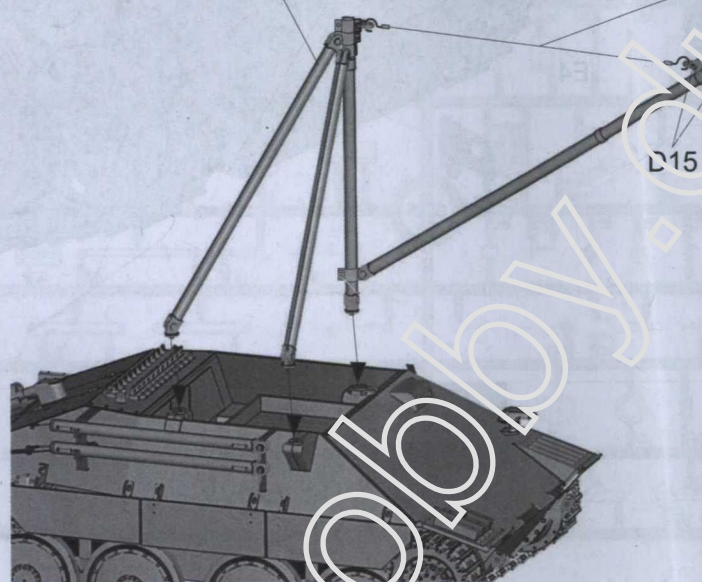

template

A41 A20

0,5mm

0,5mm

A19

0,3mm

A8

A33

A32

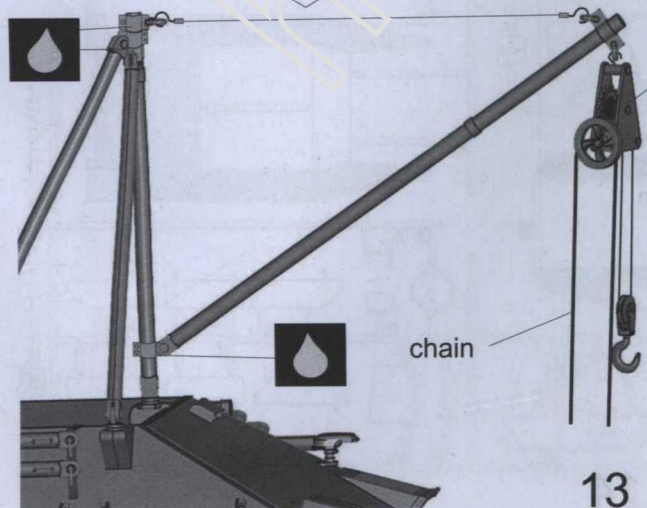

chain

A24

A23

A10

13

Pulley assembly

27

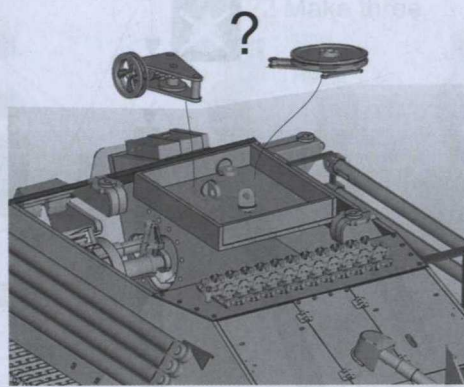
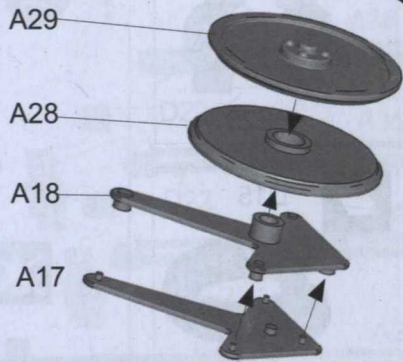

28

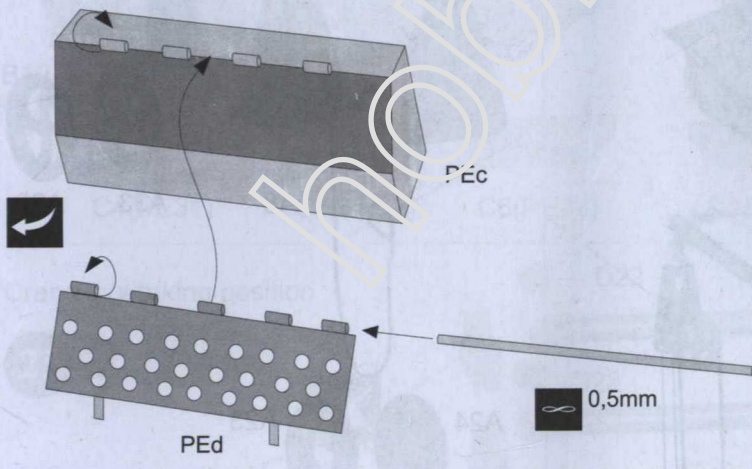
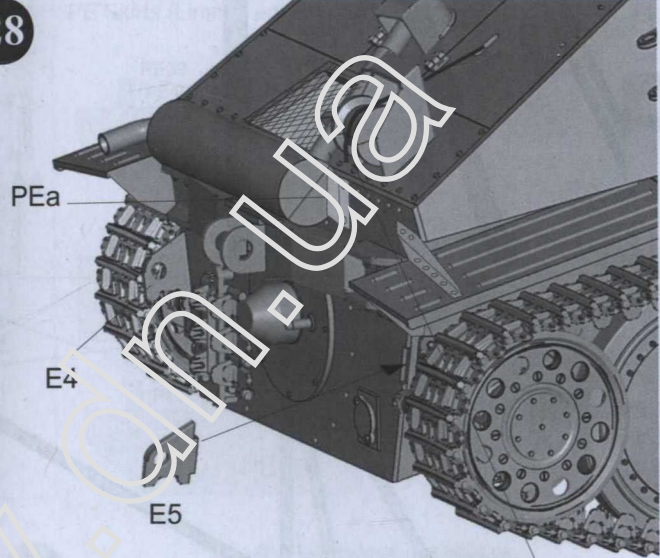
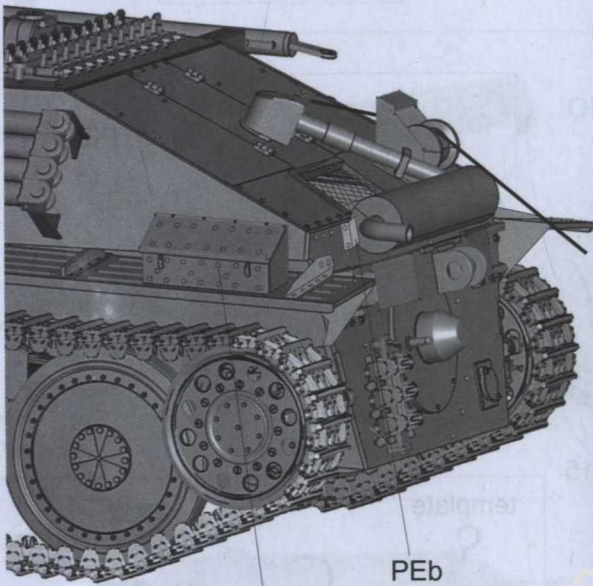

C/A

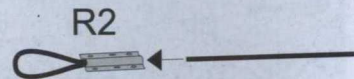

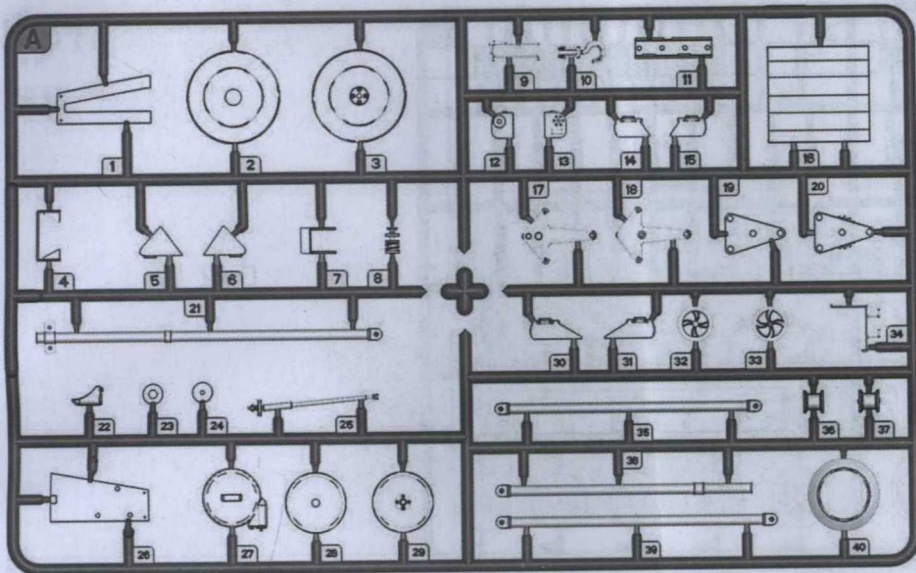

A x1

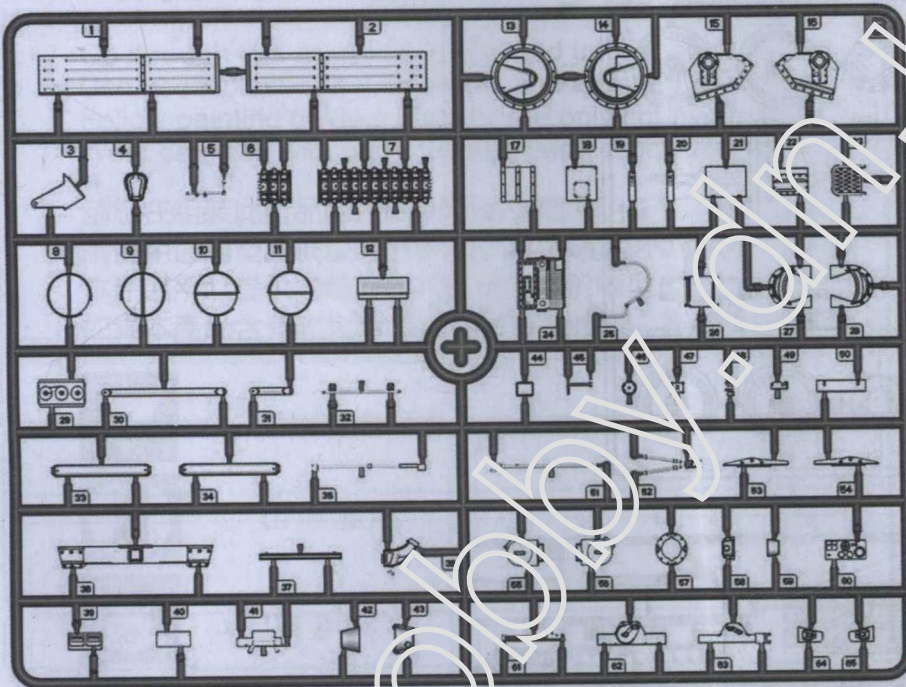

B x1

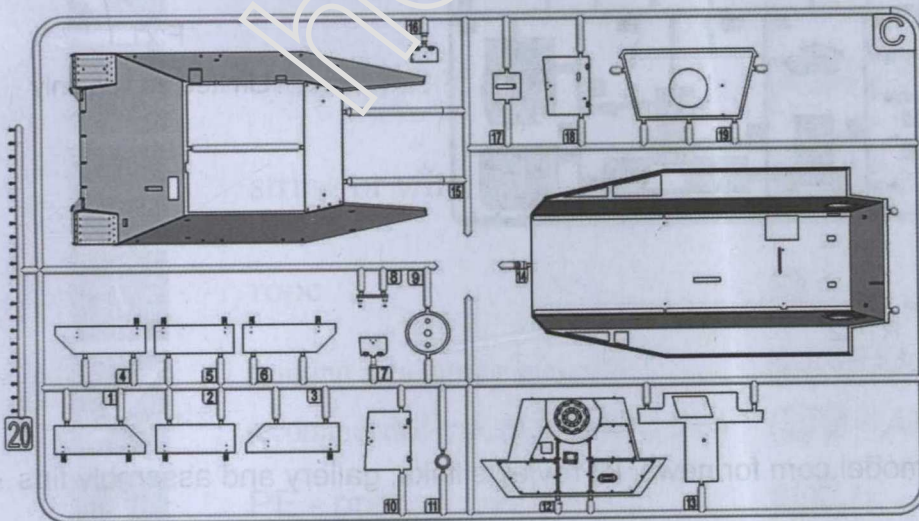

C x1

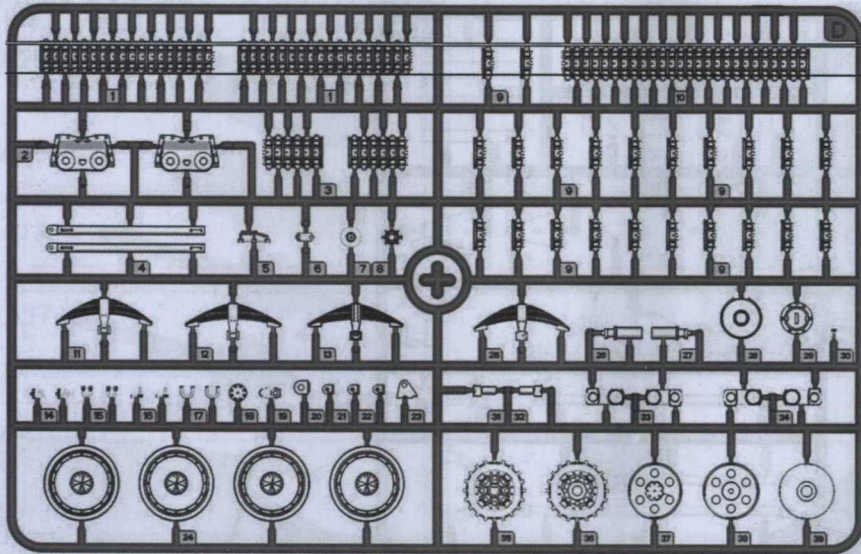

D x2

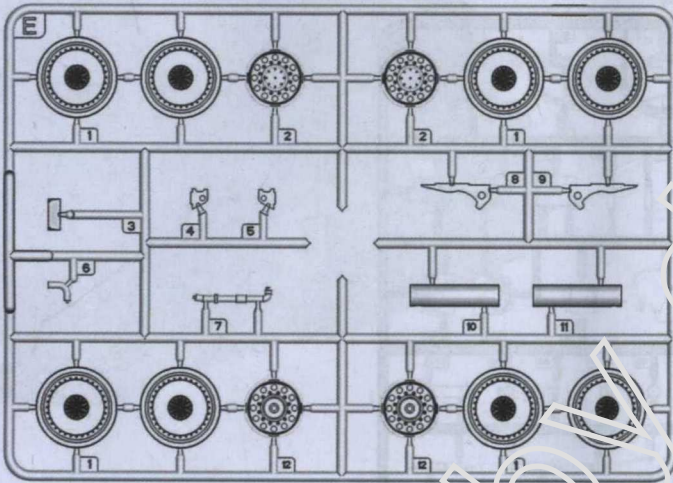

E x1

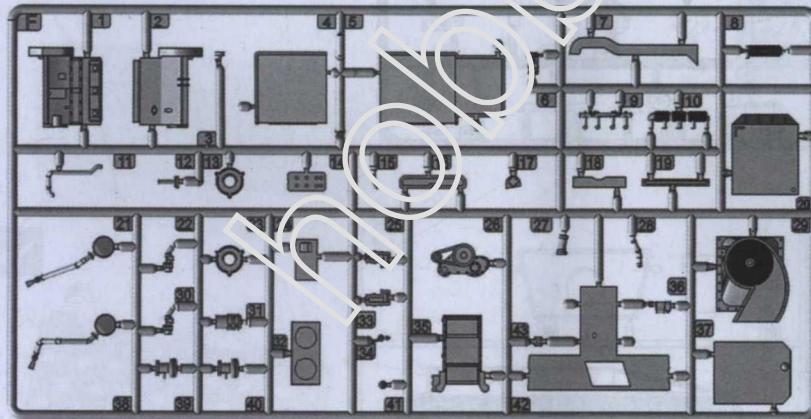

F x1  
Limited edition only



Visit us at [www.Thundermodel.com](http://www.Thundermodel.com) for news, kit reviews links, gallery and assembly tips



Color info and profiles by



# BERGEPANZER 38 HETZER EARLY

Ref: TM35102  
TM35103

## Painting and Marking Guide

Germany, Early 1945.

A.MIG 002 Olivegrün Opt.2

A.MIG 010 Dunkelgelb (Mid War)

A.MIG 014 Rotbraun

A.MIG 033 Rubber & Tires

A.MIG 035 Dark Tracks

A.MIG 036 Old Wood

A.MIG 042 Old Rust

A.MIG 096 Crystal Periscope Green

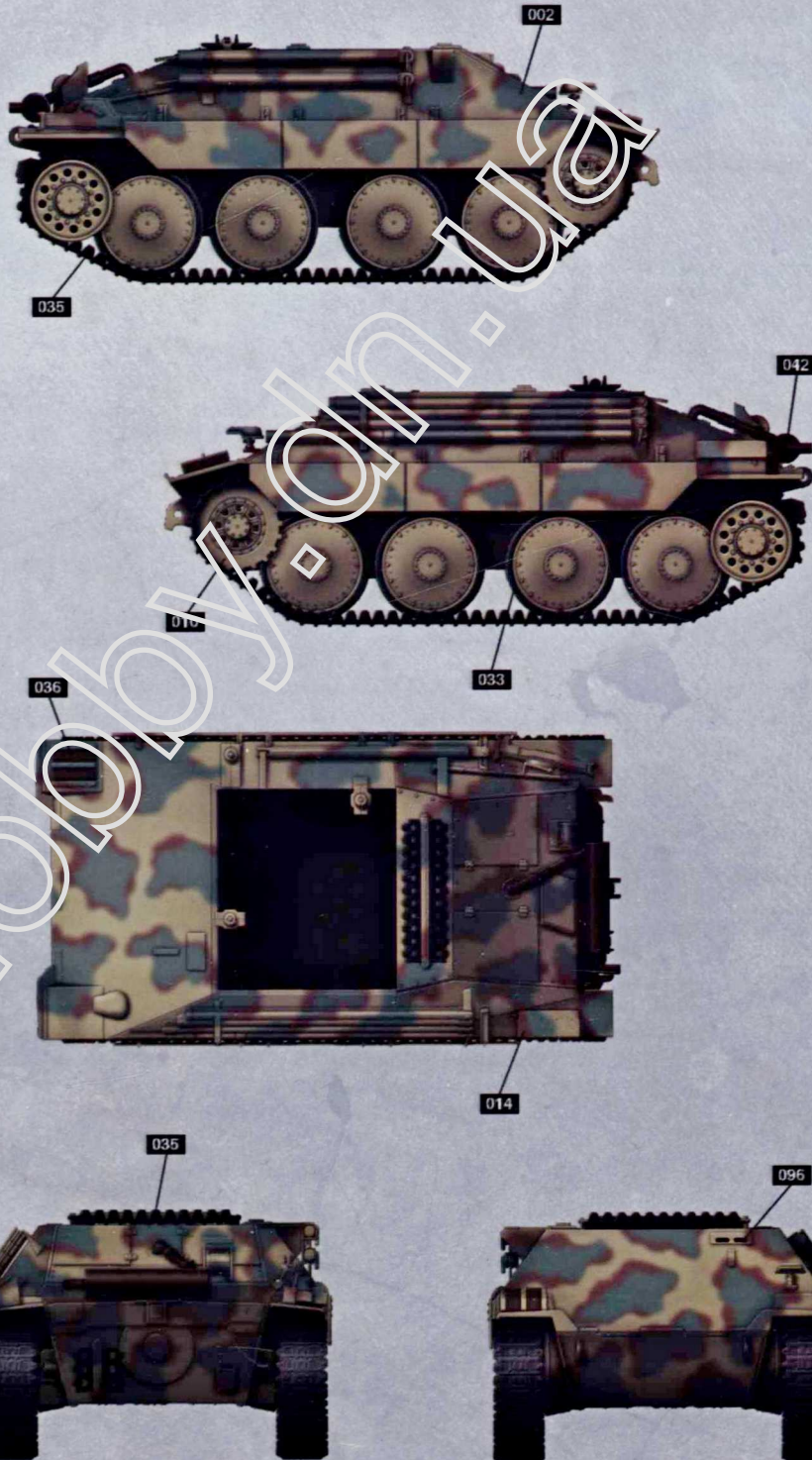





Color info and profiles by



# BERGEPANZER 38 HETZER EARLY

Ref: TM35102  
TM35103

## Painting and Marking Guide

BMM, (Prague/CKD) 1945.

A.MIG 003 Resedagrün

A.MIG 017 Cremeweiss

A.MIG 033 Rubber & Tires

A.MIG 035 Dark Tracks

A.MIG 036 Old Wood

A.MIG 042 Old Rust

A.MIG 070 Medium Brown

A.MIG 096 Crystal Periscope Green

