

72098 Bristol Bombay Mk.I 1/72

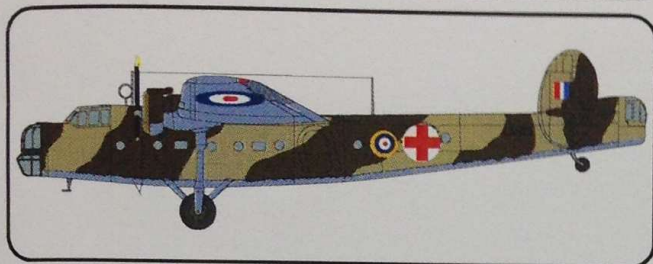

### Stručná historie Bristol Bombay Mk.I.

Letoun Bristol Bombay patří do zvláštní kategorie z hlediska určení jako dopravní bombardér. Byl vyvíjen jako dopravní letoun se schopností nést náklad bomb. Uplatnění takovéto kategorie letounu bylo především v koloniích britského impéria, kde nehrozilo nebezpečí od protiletectvé obrany.

V roce 1931 vypsalo britské Ministerstvo letectví specifikaci C.26/31 na takovýto typ letounu. Firma Bristol Aeroplane Company se jí zúčastnila s projektem typu 130. Bristol 130 byl hornoplošník celokovové konstrukce s pevným podvozkem. Svislé ocasní plochy byly dvojitě a do prostorného trupu bylo možno pojmout až 24 vojáků. Variabilnost prostoru se dala využít i pro transport raněných s nosítky nebo jako nákladní pro náhradní díly apod. V přední a zadní části trupu bylo prosklené stříliště vždy s jedním kulometem Lewis ráže 7,7 mm.

Prototyp byl zalétán 23. června 1935 na letišti Filton. Zkoušky prokázaly některé nedostatky, které vedly k určitým změnám pro sériové stroje. Jednalo se zejména o změnu přední střelecké věže, nahrazení dvoulistých vrtulí třílistými silnějšími motory Bristol Pegasus XXII o výkonu 772 kW (oproti původním Bristol Pegasus III o výkonu 559 kW). Další změny zaznamenaly svislé ocasní plochy a byly odstraněny tzv. "bačkory" tedy kovové kryty podvozků. Posádka byla tříčlená a tvořil ji pilot, operátor a navigátor.

Sériová výroba byla započata v březnu 1939. Bylo objednáno 80 kusů pod novou zakázkou 47/36 z roku 1936. Letoun dostal bojové jméno Bombay. První stroje byly dislokovány u 216. Squadrony v Egyptě. Již 5 dní po vyhlášení války Itálií proti Velké Británii bombardoval osamělý Bombay dne 15. června 1940 Tobruk obsazený italským vojsky. Bombay mohl nést až 908 kg pum ráže 250 Lb (113,4 kg) na osmi podtrupových závěsnících. Tyto nálety však byly sporadické, prováděné většinou v noci a jejich účinnost byla nevalná. Většinou byly používány k přepravě raněných, výsadkářů, zásob a náhradních dílů. Za zmínku stojí i přeprava 6000 raněných vojáků ze Sicílie do Itálie provedená jednou posádkou při 200 letech v roce 1943, nebo přeprava řecké královské rodiny z Kréty do Egypta v květnu 1941.

Bombay sloužil zejména na středním východě u 216 Sqn. až do června 1943. Používány byly i u No.1 Australian Ambulance Unit, RAAF ještě v roce 1944.

Celkem bylo vyrobeno 50 kusů.

#### Technická data:

Rozpětí (m)	29,2
Délka (m)	21,1
Výška (m)	6,1
Max. rychlost (km/hod)	300
Dolet (km)	4000
Dostup (m)	6650

VALOM

Zlešická 1808/10 144 00 Praha 4 - Chodov  
Czech Republic



### A brief history of the Bristol Bombay Mk. I

The Bristol Bombay is a special category of aircraft because of its intended use as transport aircraft/bomber. It was developed as a transport aircraft that was capable of carrying a cargo of bombs. This category of aircraft was mainly used in the colonies of the British Empire where there was no threat of anti-aircraft defence.

The British Air Ministry assigned a C.26/31 Specification to this type of plane in 1931. The Bristol Aeroplane Company provided a Type 130 project, the Bristol 130 being a high-wing aircraft with all-metal construction and a fixed undercarriage. It had an upright twin-tail and the spacious fuselage could hold up to 24 soldiers. The variability of the space meant it could also be used to transport wounded men on stretchers or as a cargo plane for spare parts etc. The front and rear parts of the fuselage had a glassed-in gun turret with a single Lewis 7.7 mm machine gun.

The prototype first flew on 23<sup>rd</sup> June 1935 from the airfield at Filton. Tests showed certain shortcomings, which led to changes being made before the aircraft was mass produced. This mainly involved a change to the nose-end gun turret, the replacement of the two-bladed propeller with a three-bladed propeller and the use of more powerful 772 kW Bristol Pegasus XXII engines (as opposed to the original 559 kW Bristol Pegasus III engine). Other changes were made to the upright tail and the wheel spats, the metal undercarriage covers, were removed. The crew consisted of three men – a pilot, an operator and a navigator.

Batch production got underway in March 1939, with 80 aircraft having been ordered under new contract 47/36 from 1936. The aircraft was given the battle name of Bombay. The first planes were delivered to No. 216 Squadron RAF in Egypt. A lone Bombay bombed Tobruk, which was occupied by Italian soldiers, on 15<sup>th</sup> June 1940, some 5 days after Italy declared war on Great Britain. The Bombay was able to carry up to 908 kg of 250-pound bombs (113.4 kg) in eight racks on the undercarriage. These sorties were sporadic, however, mostly at night and with meagre effect. Mostly they were used to carry the wounded, paratroopers, supplies and spare parts. Worthy of note is the transportation of 6,000 wounded soldiers from Sicily to Italy, a feat managed in 1943 by a single crew over 200 flights, or transportation of the Greek royal family from Crete to Egypt in May 1941.

The Bombay mainly served in the Middle East at No. 216 Squadron until June 1943. It was also used by No. 1 Australian Ambulance Unit, RAAF, until 1944.

Fifty aircraft were made in total.

#### Technical Data:

Span (ft)	95,75
Length (ft)	69,25
Height (ft)	16,50
Top speed (mph)	186
Range (mils)	2500
Ceiling (ft)	21800



Plastikové díly

Plastic Parts

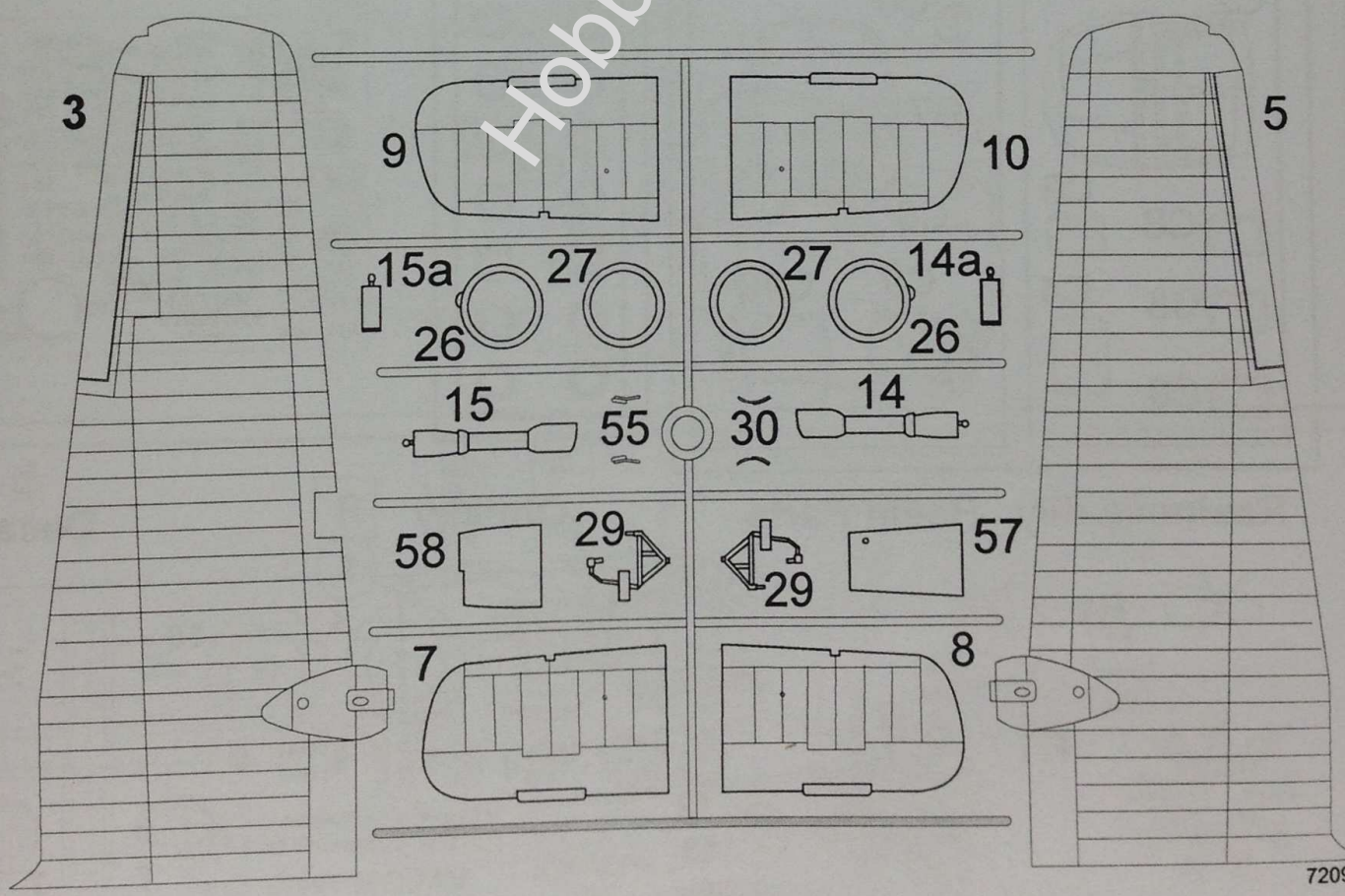
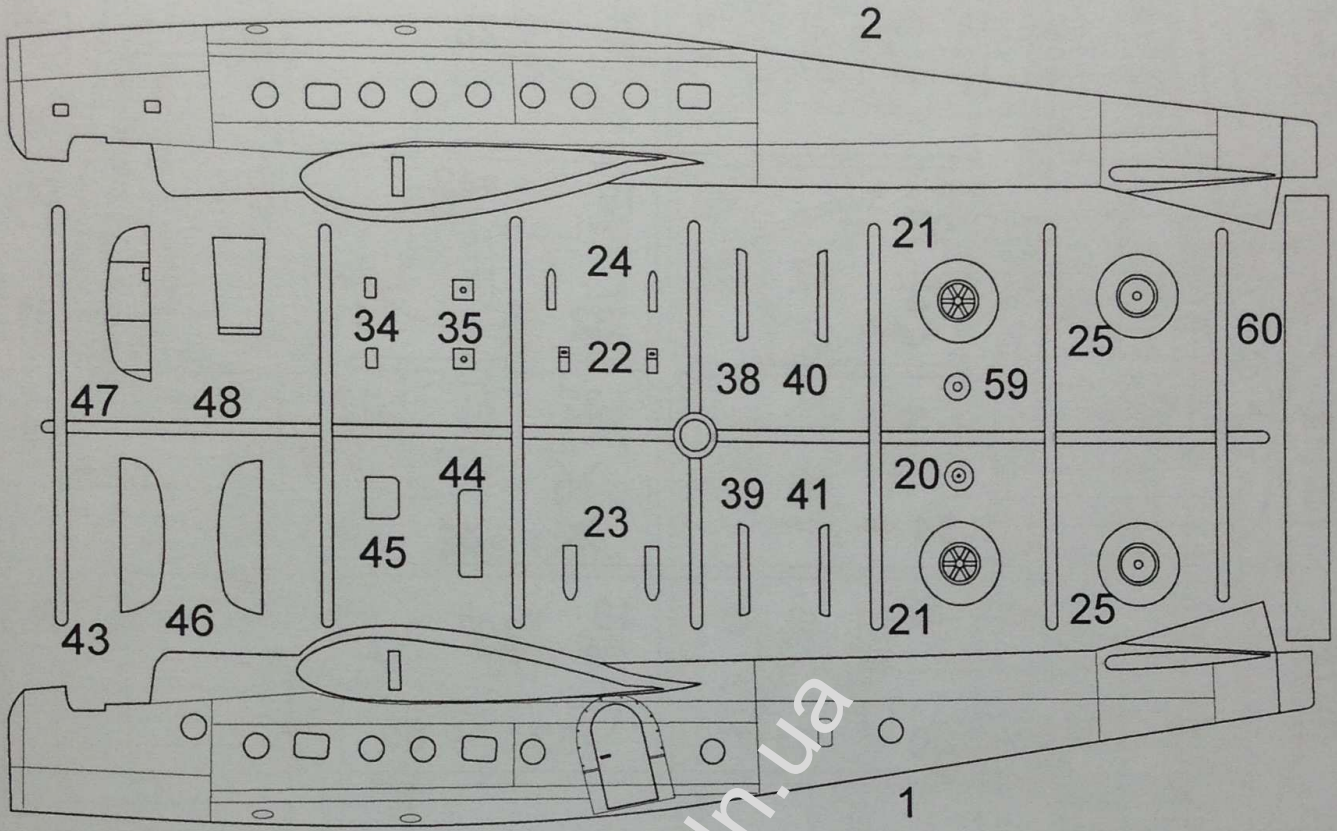



Plastikové díly

Plastic Parts

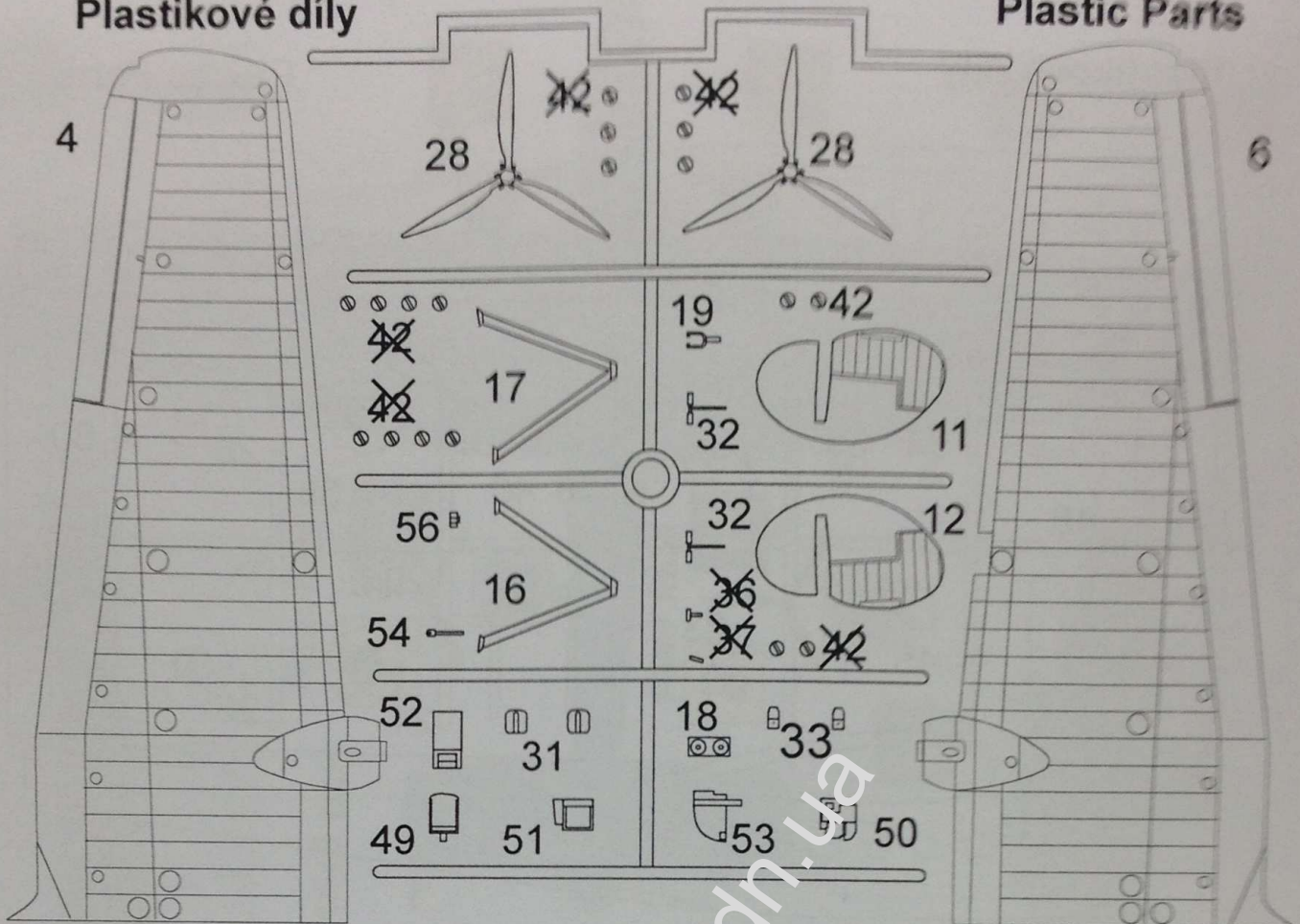

Průhledné díly

Clear Parts

Kovové díly Metal Parts

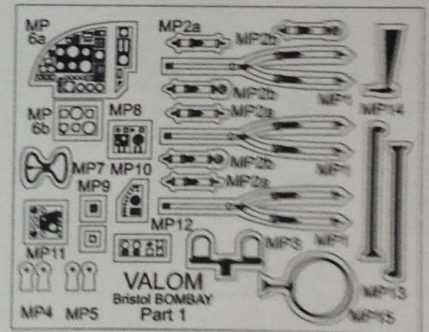
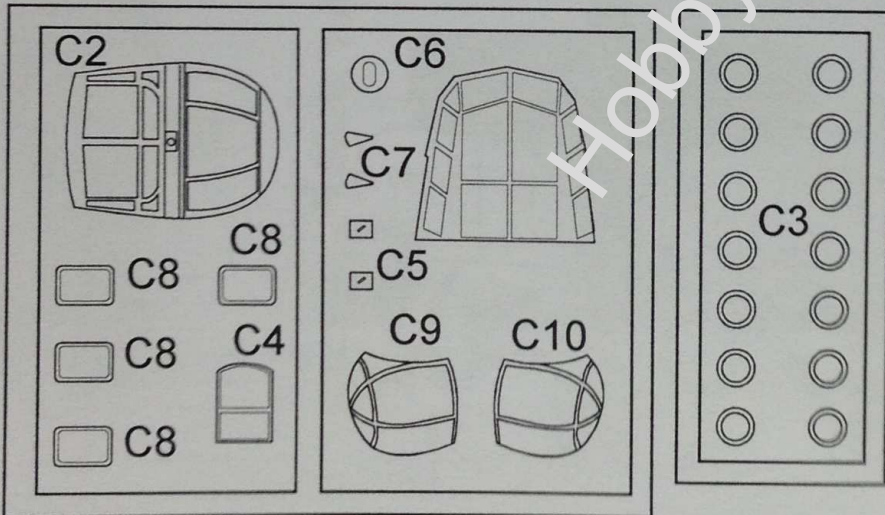

Resinové díly Resin Parts

Obtisky

Decals

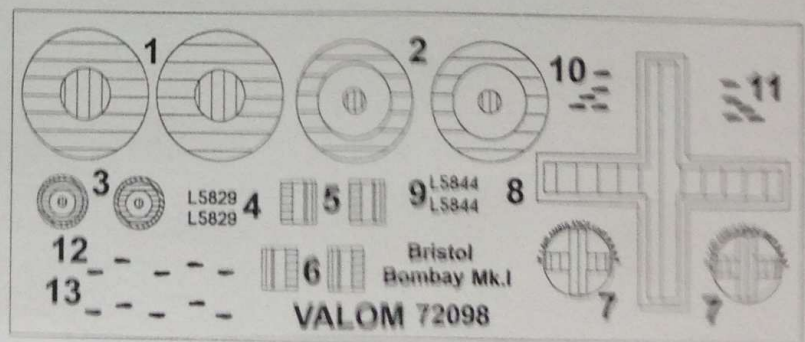
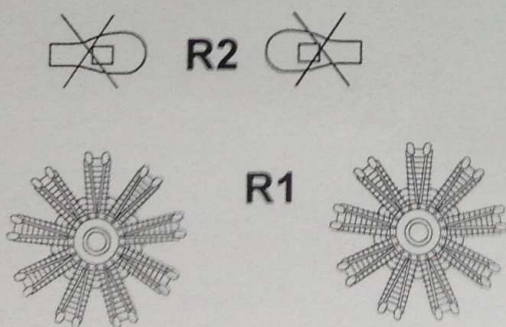



1

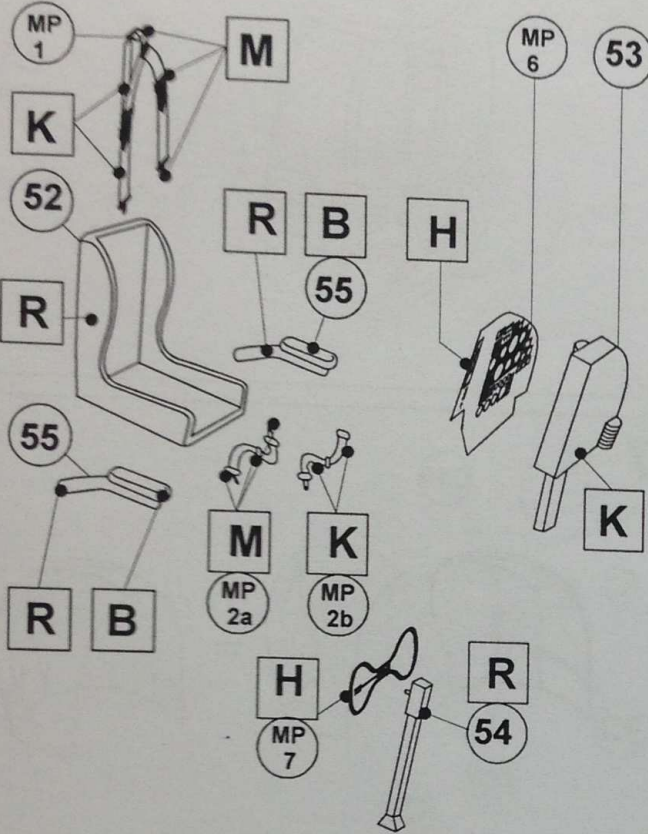

2

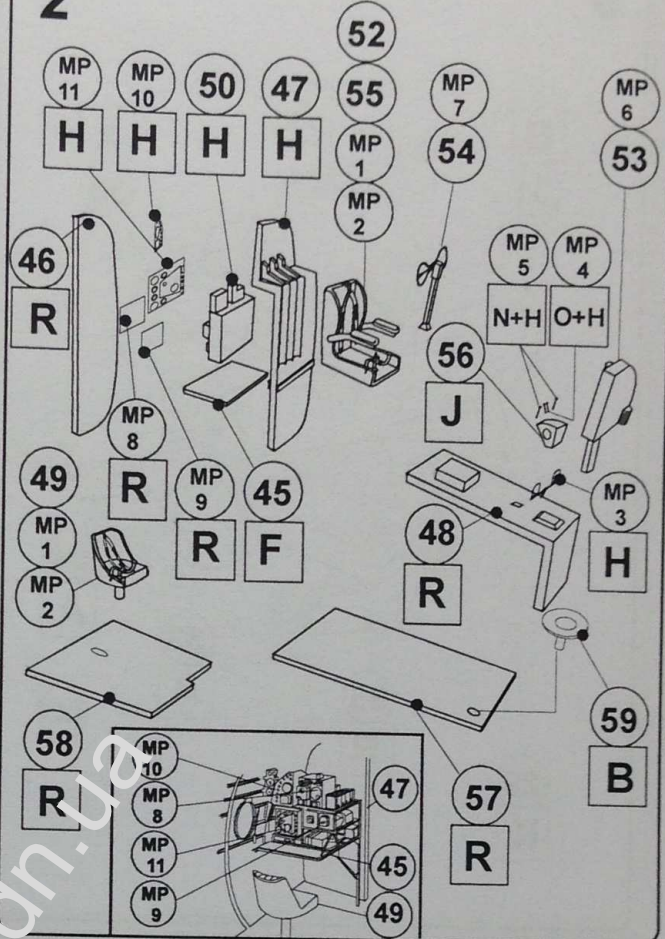

3

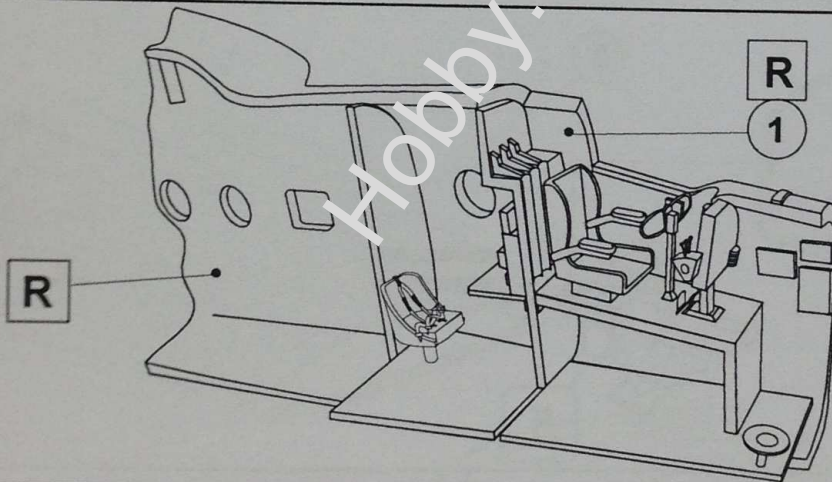

4

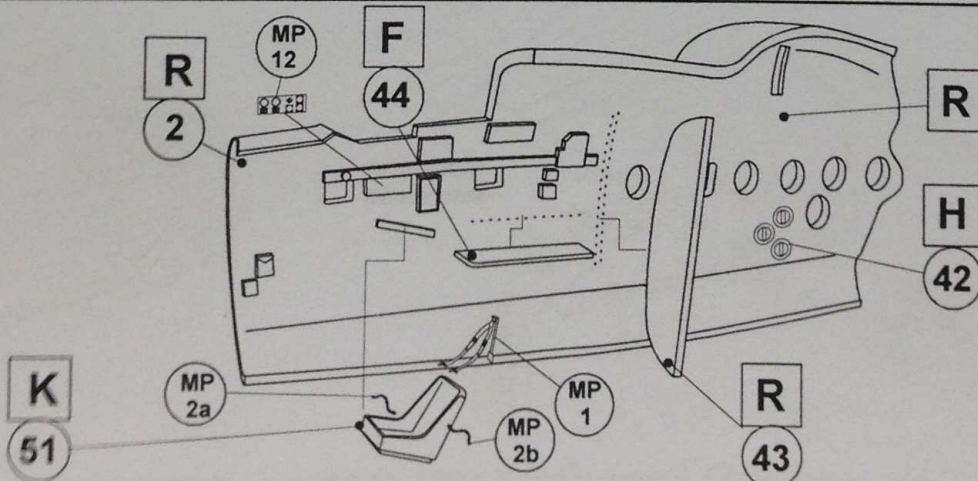



5

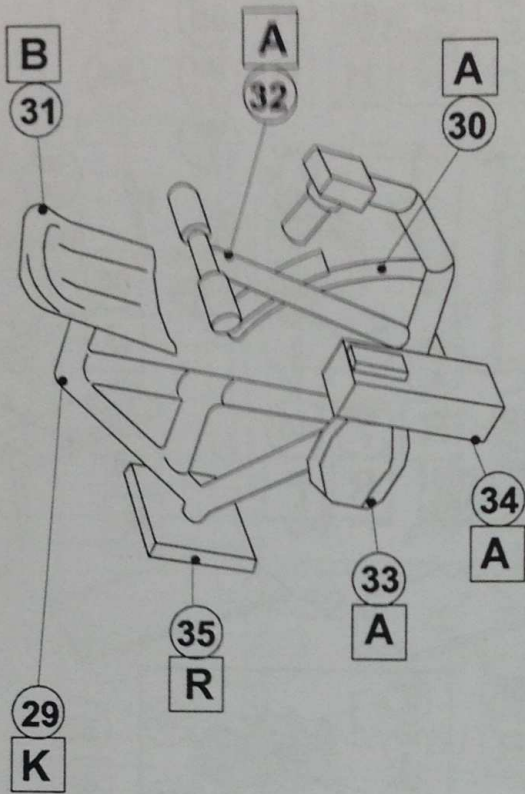

6

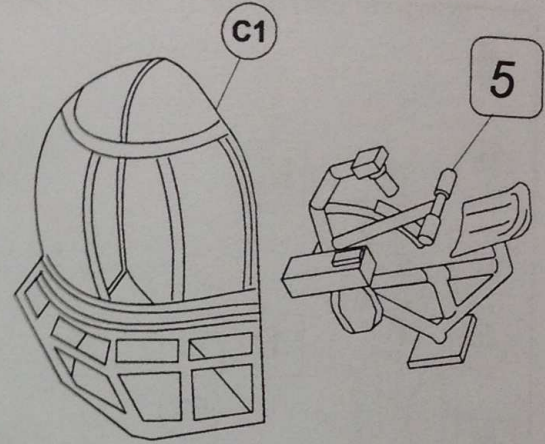

7

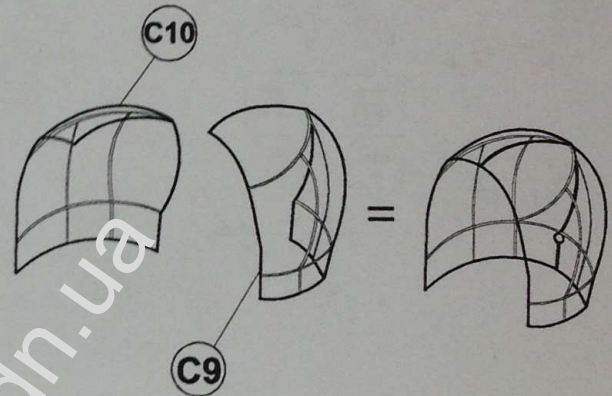

8

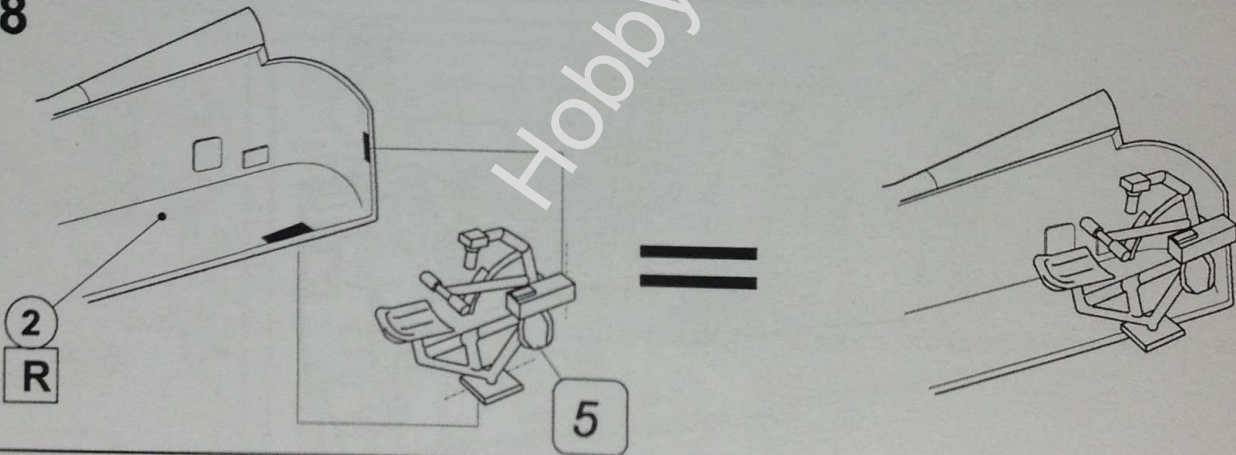

9

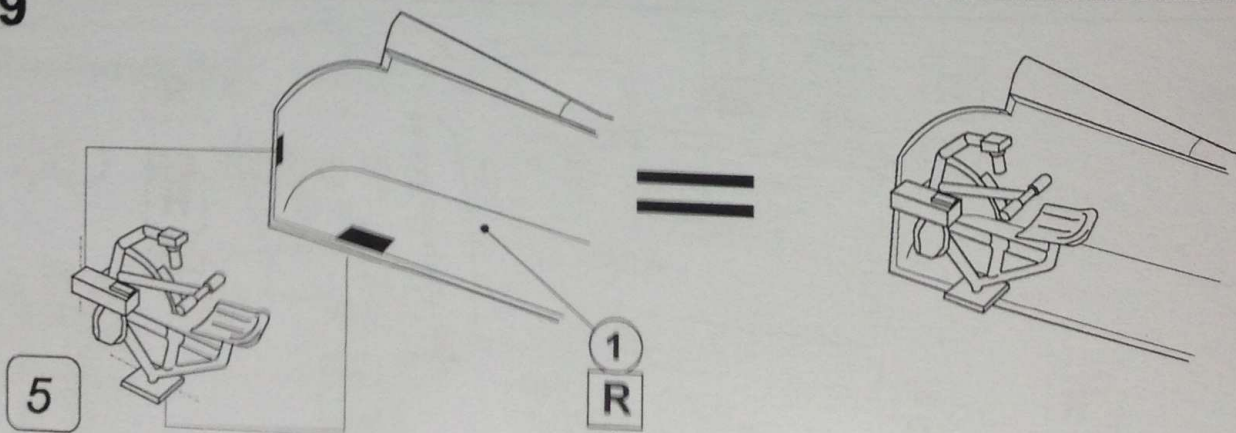



10

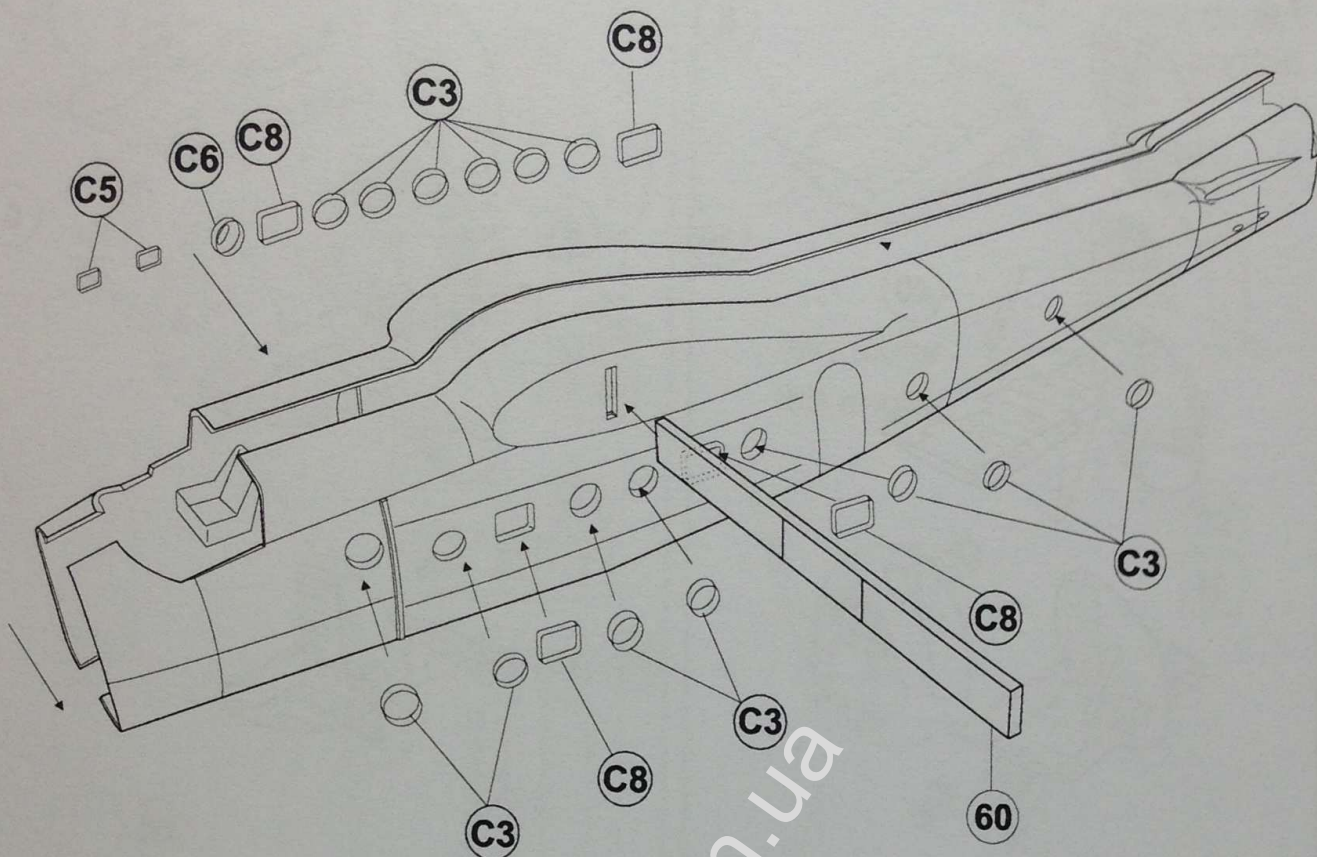

11

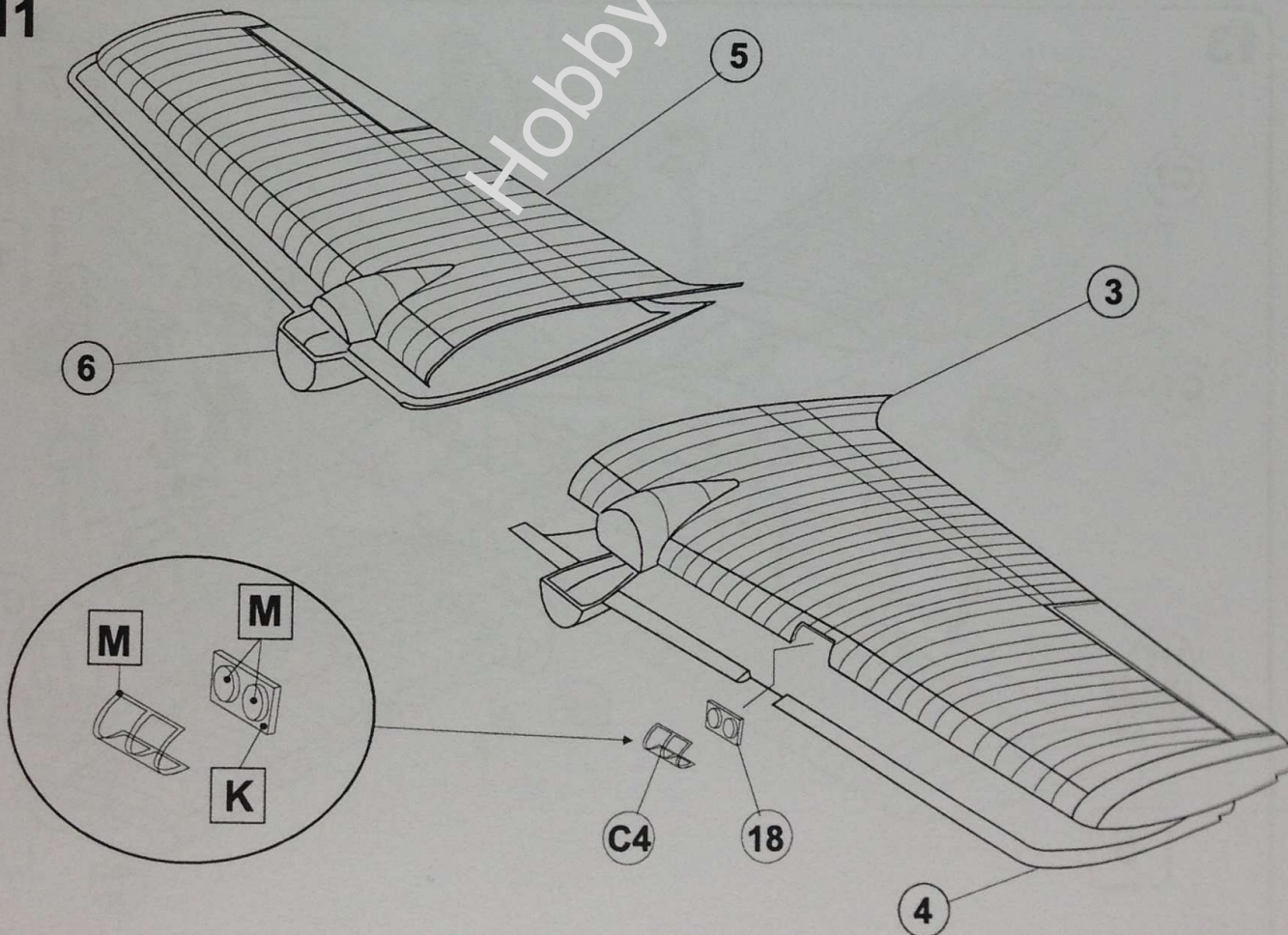



12

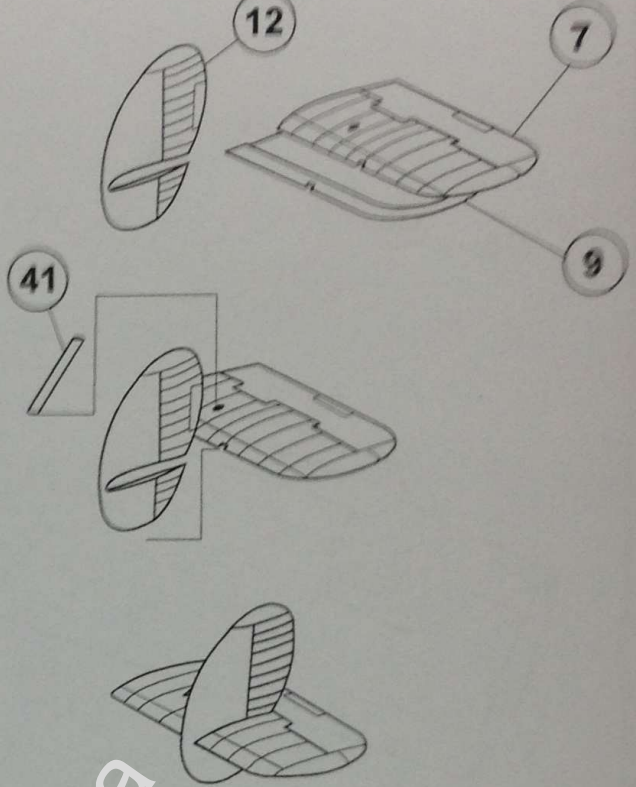
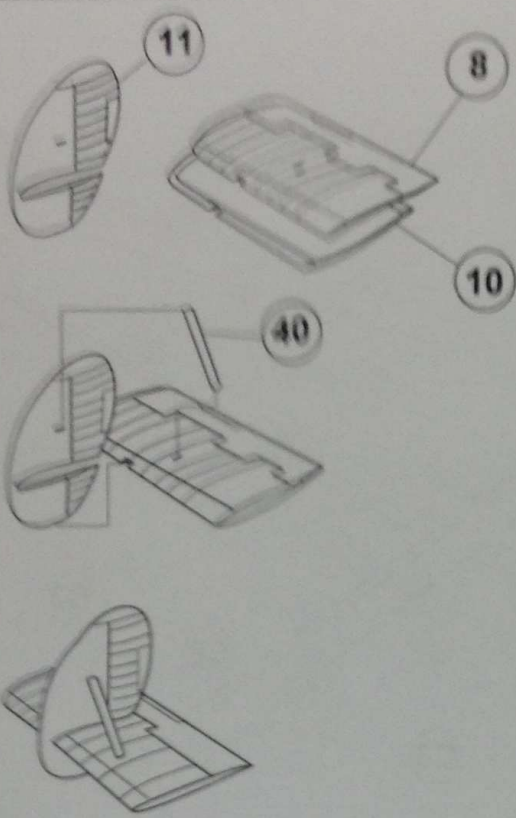

13

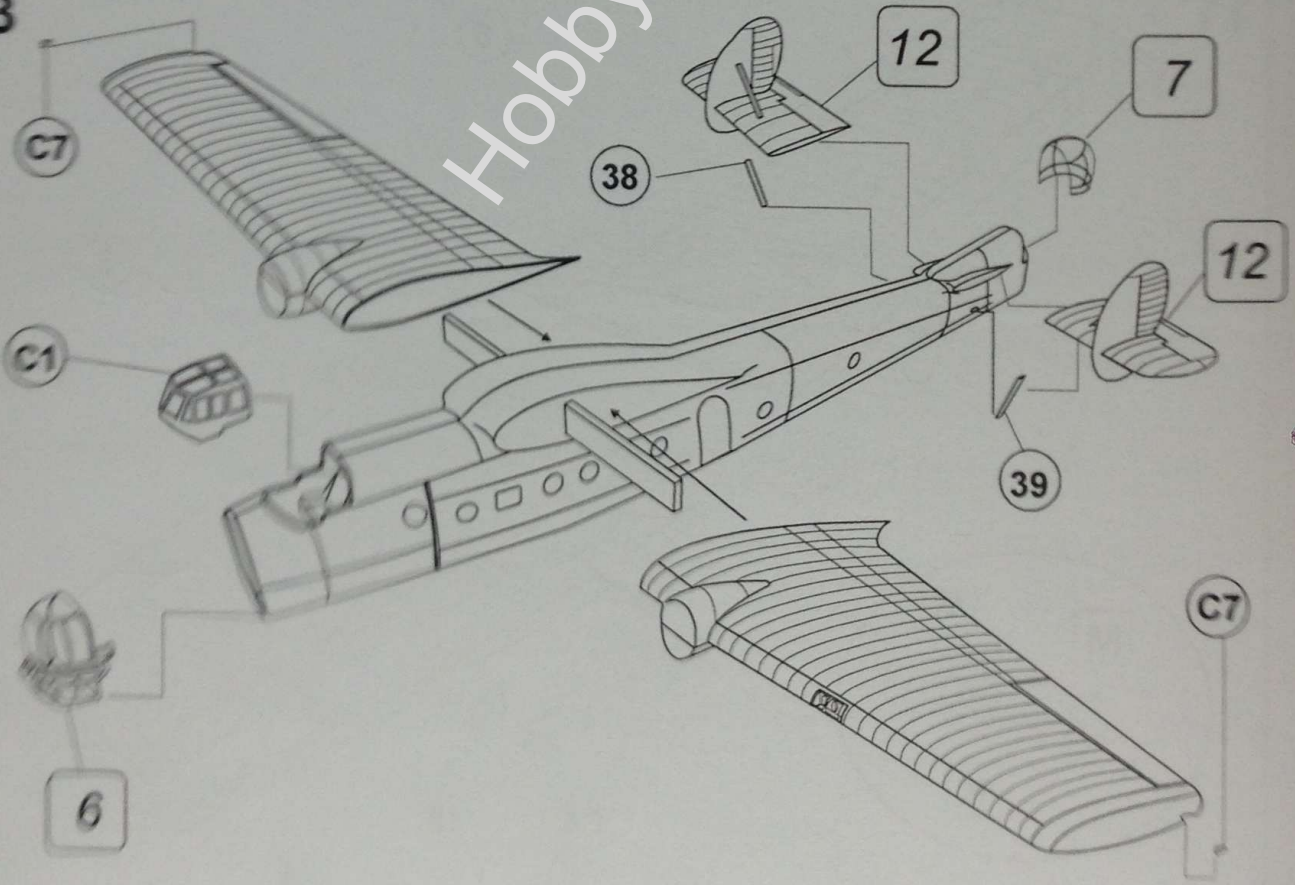



14

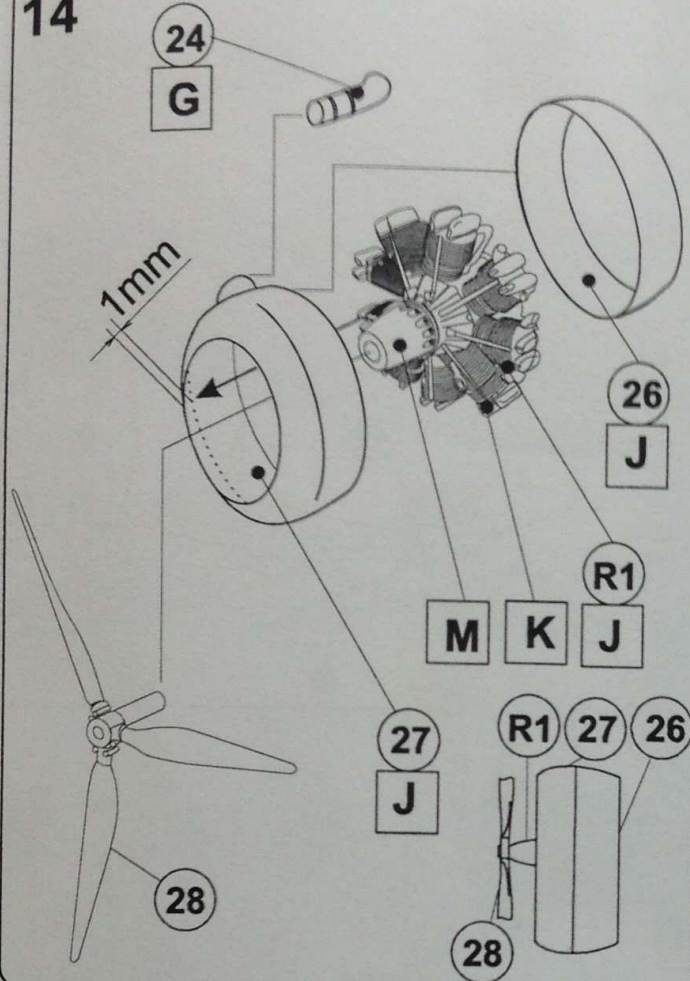

15

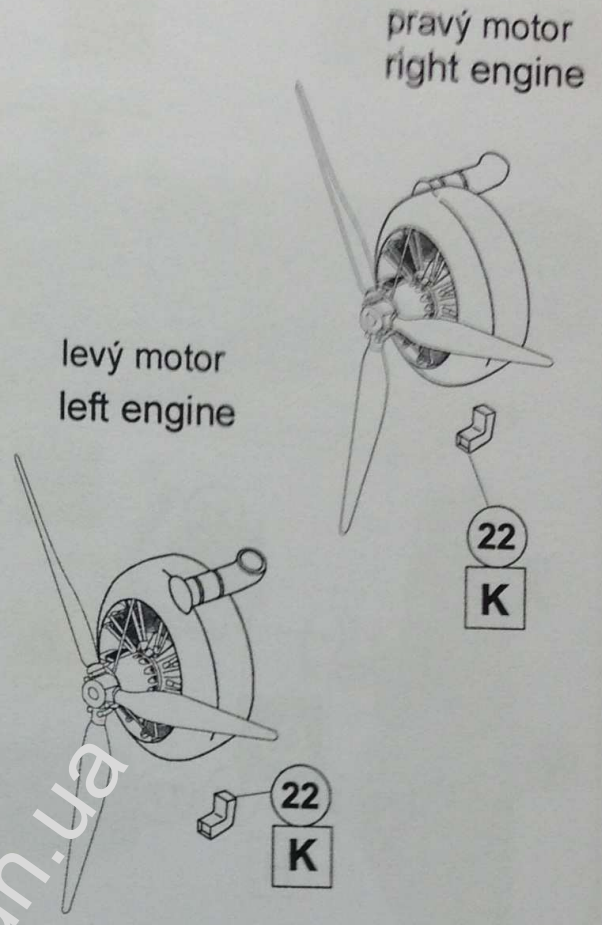

16

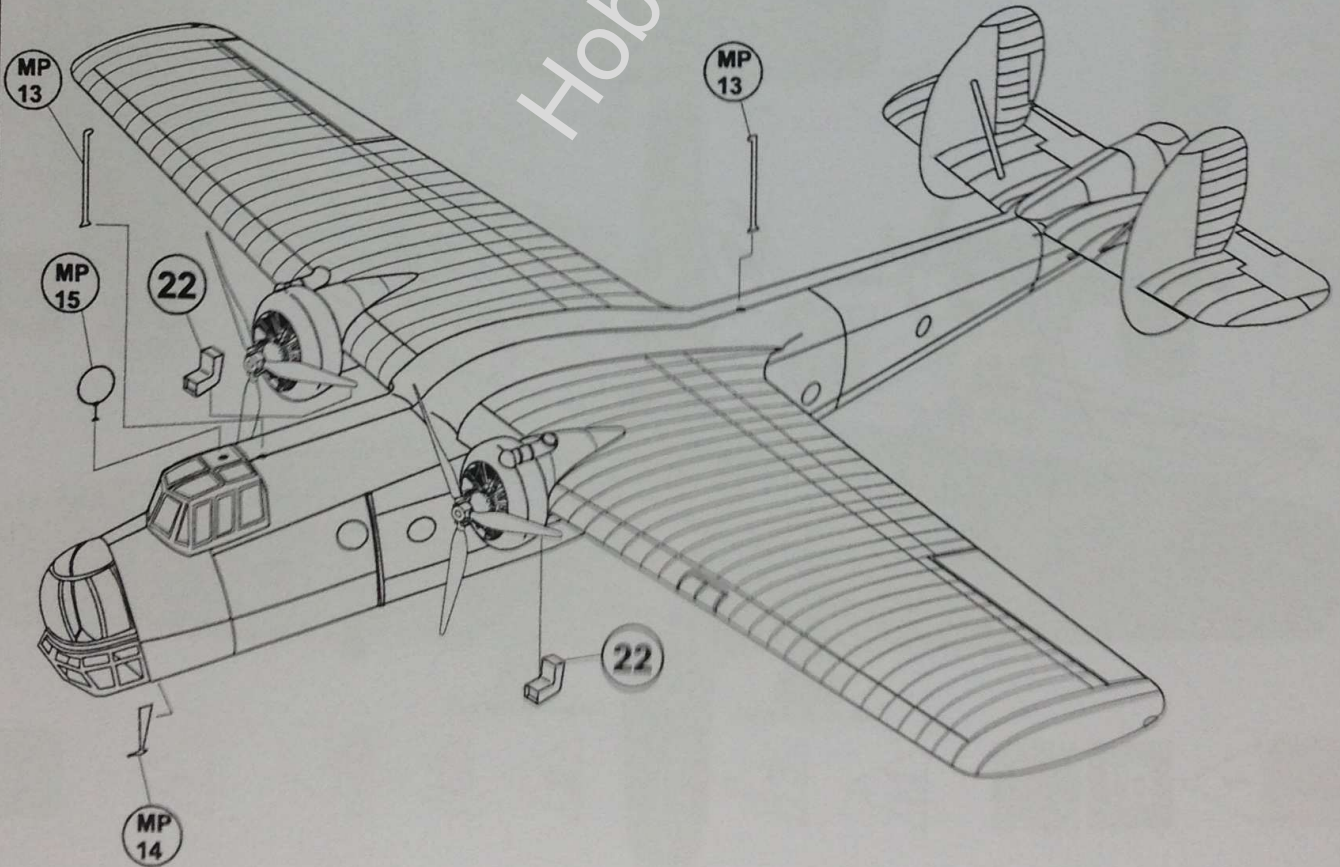



17

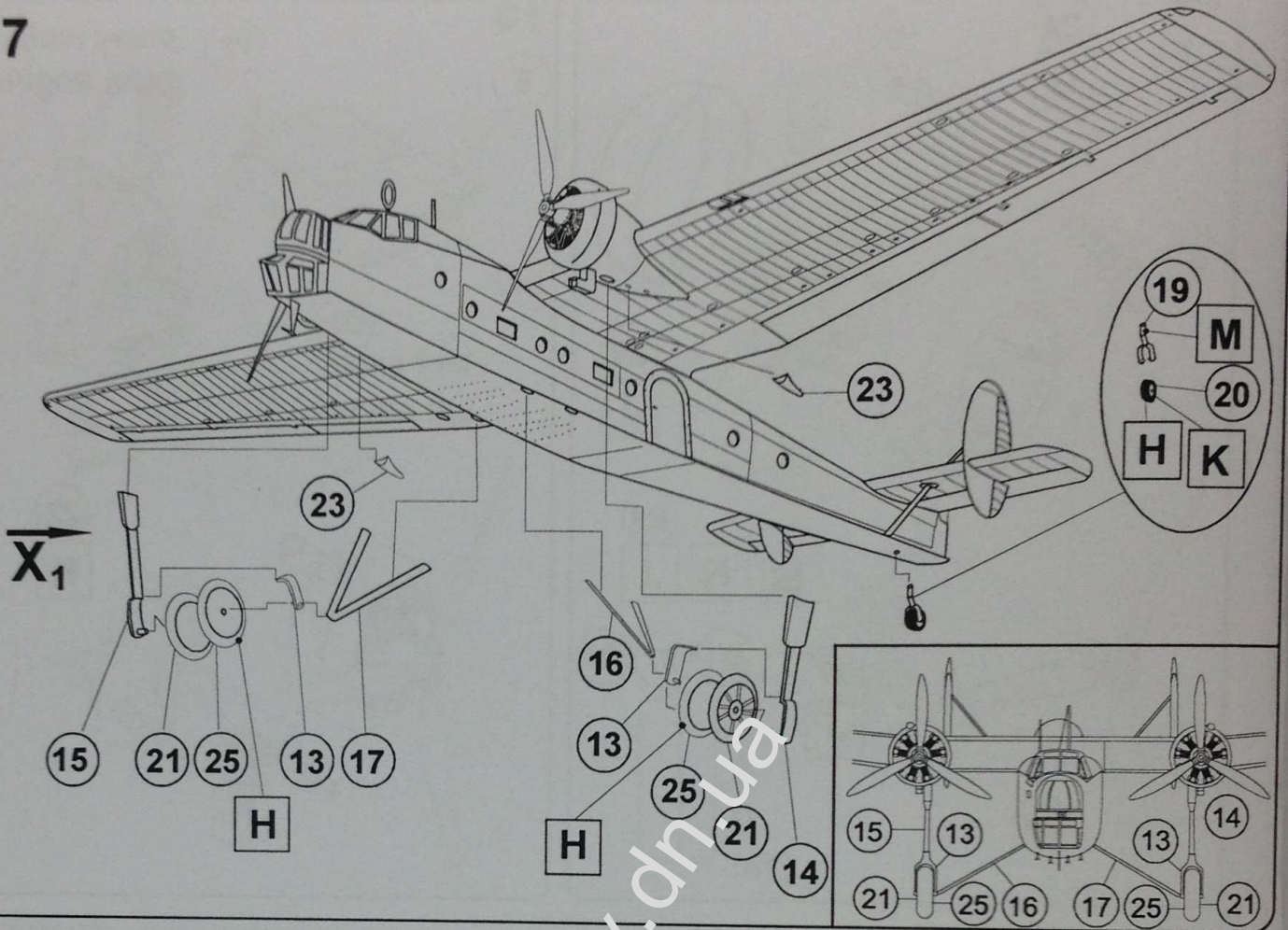

18





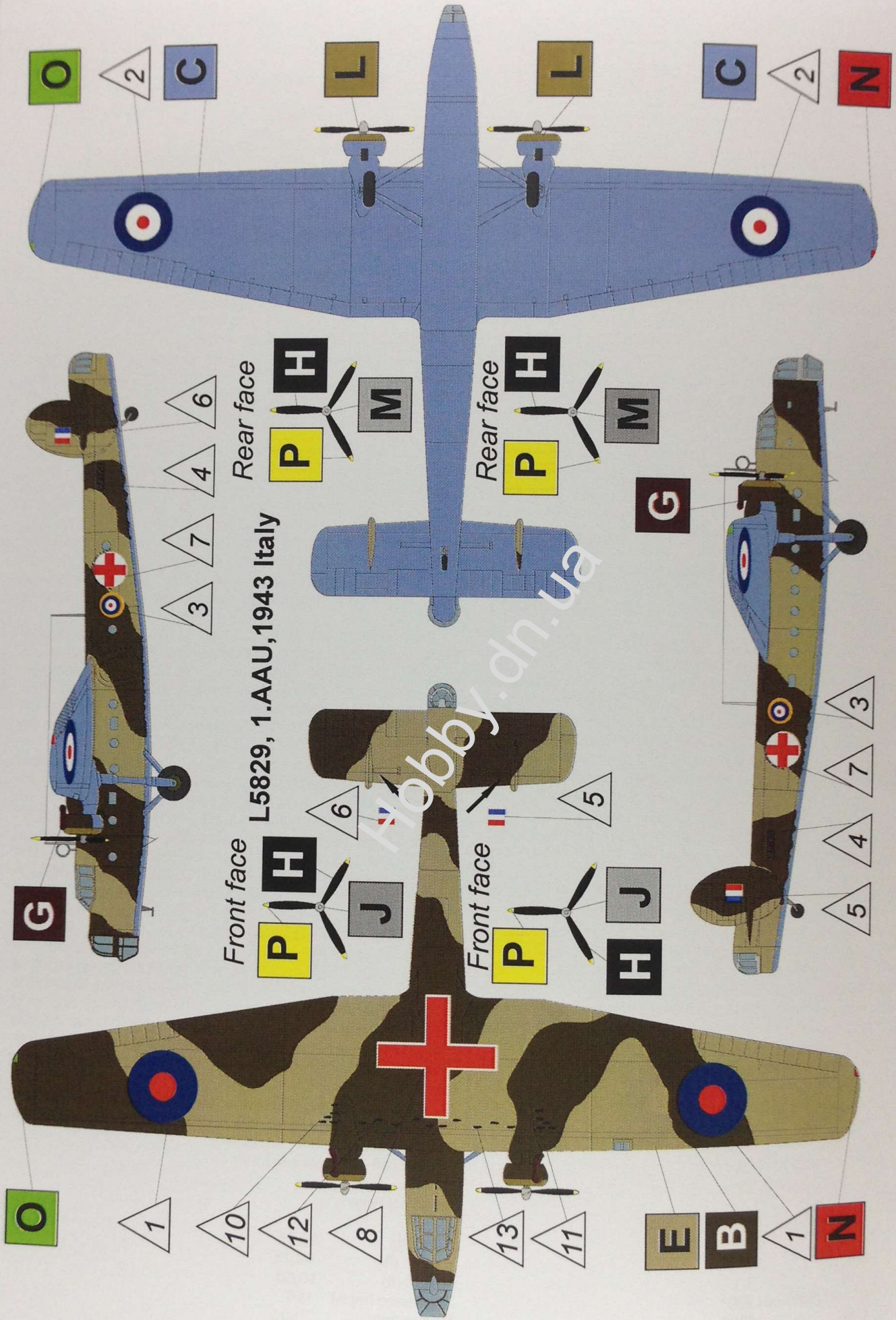

L5829, 1.AAU, 1943 Italy

Bristol Bombay Mk.I



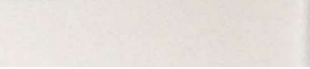
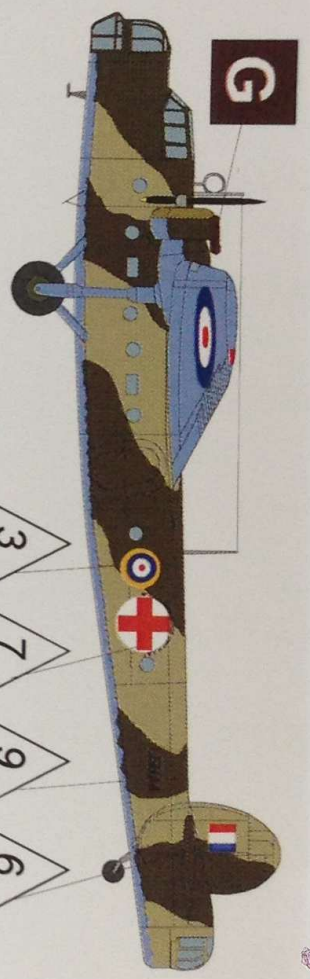
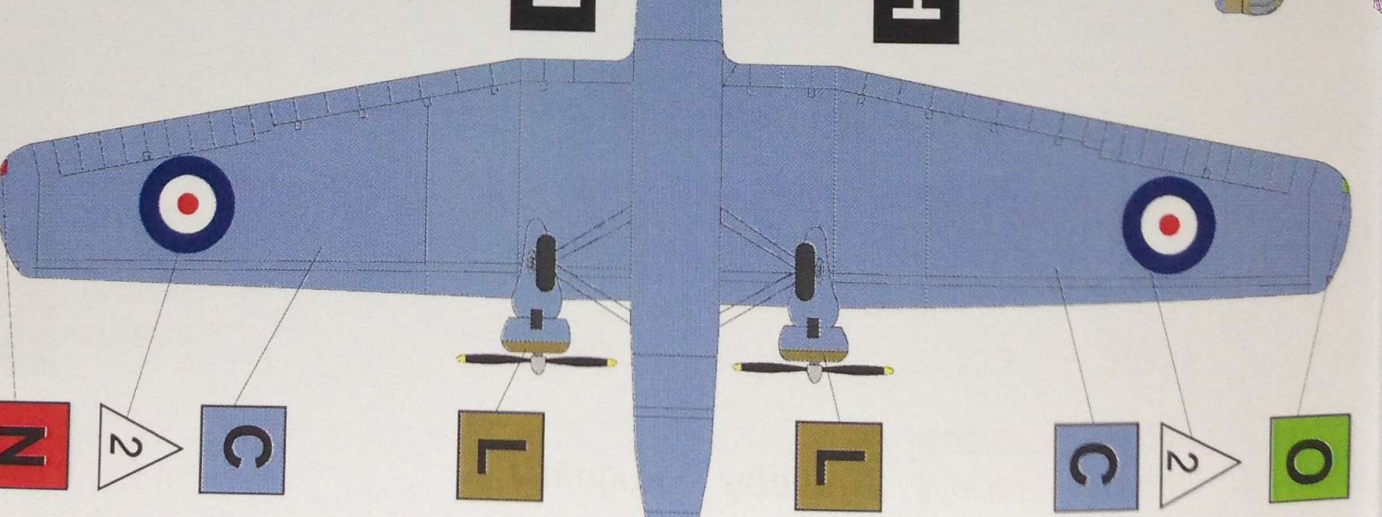
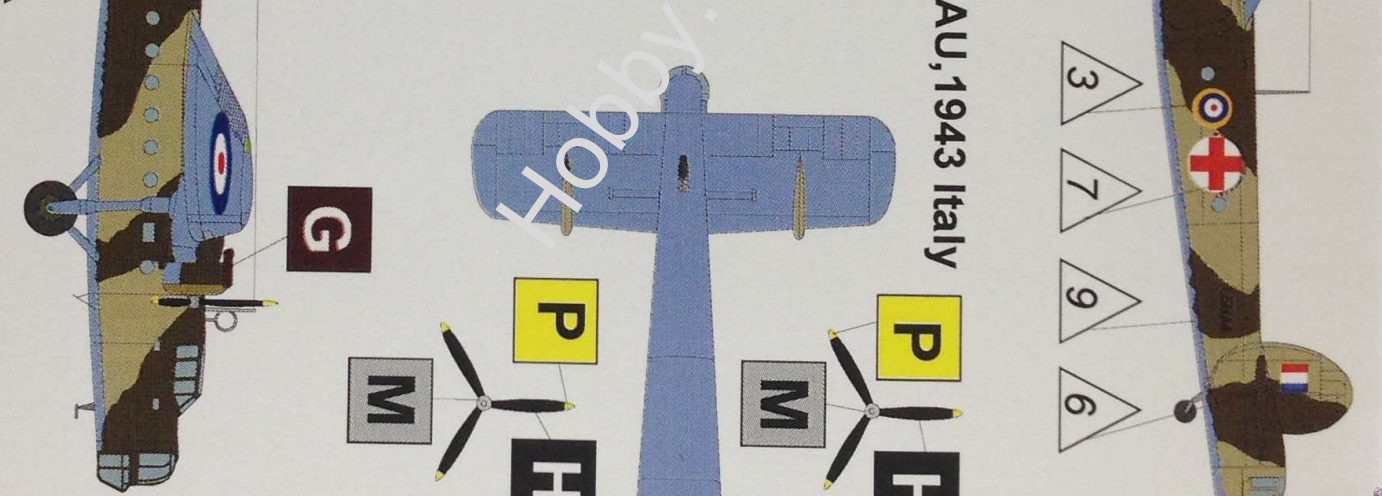
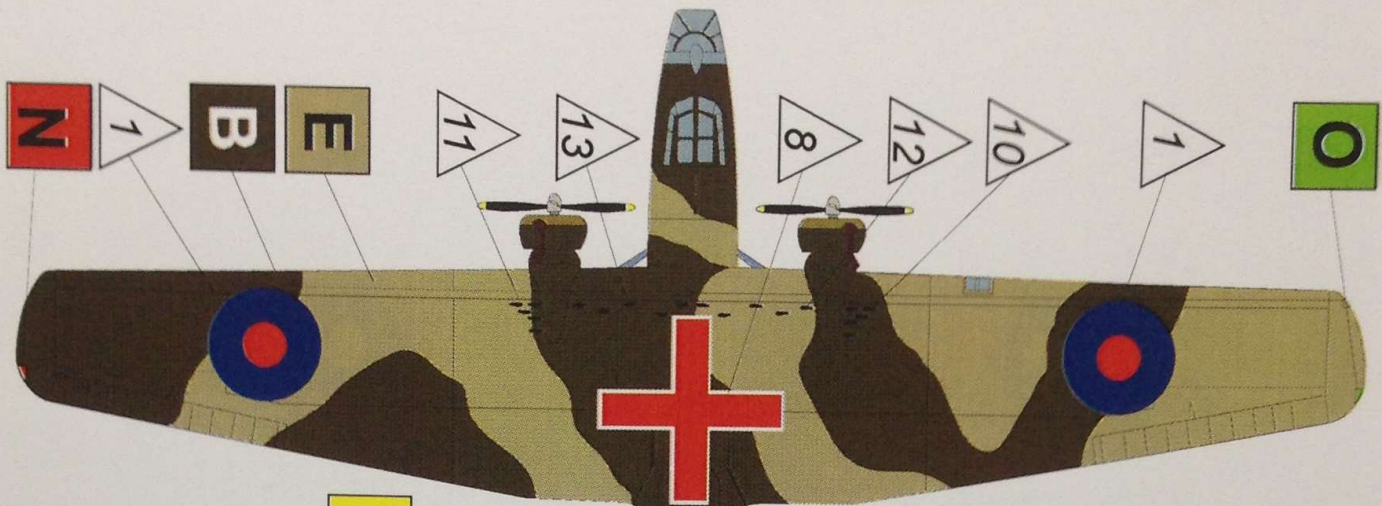

L5844, 1.AAU, 1943 Italy

en-ur-qqoH