

# Polikarpov R-5 VVS Flying School

The R-5 was a biplane reconnaissance and light bomber that was produced in vast numbers in the Soviet Union in the pre-war years.

The R-5 was designed while N. Polikarpov was working as the chief designer at Moscow's №25 factory. It was designed to be simple to fly, have a long life and be of wooden construction. It was designed around the BMW VI inline engine, which then entered licence production in the SU as the M-17.

The R-5 became the standard reconnaissance, bomber and attack aircraft with the SU AF, being used in large numbers, with over 100 air regiments equipped with the R-5. This aircraft took active part in the Nomonhan Incident, Soviet invasion of Poland and Winter War against Finland. They remained in service during the war against Germany in 1941-45, where they were mainly used as night bombers and liaison aircraft, serving until 1945!

Eventually 7.000 aircraft were built over seven (1930-1936) years.

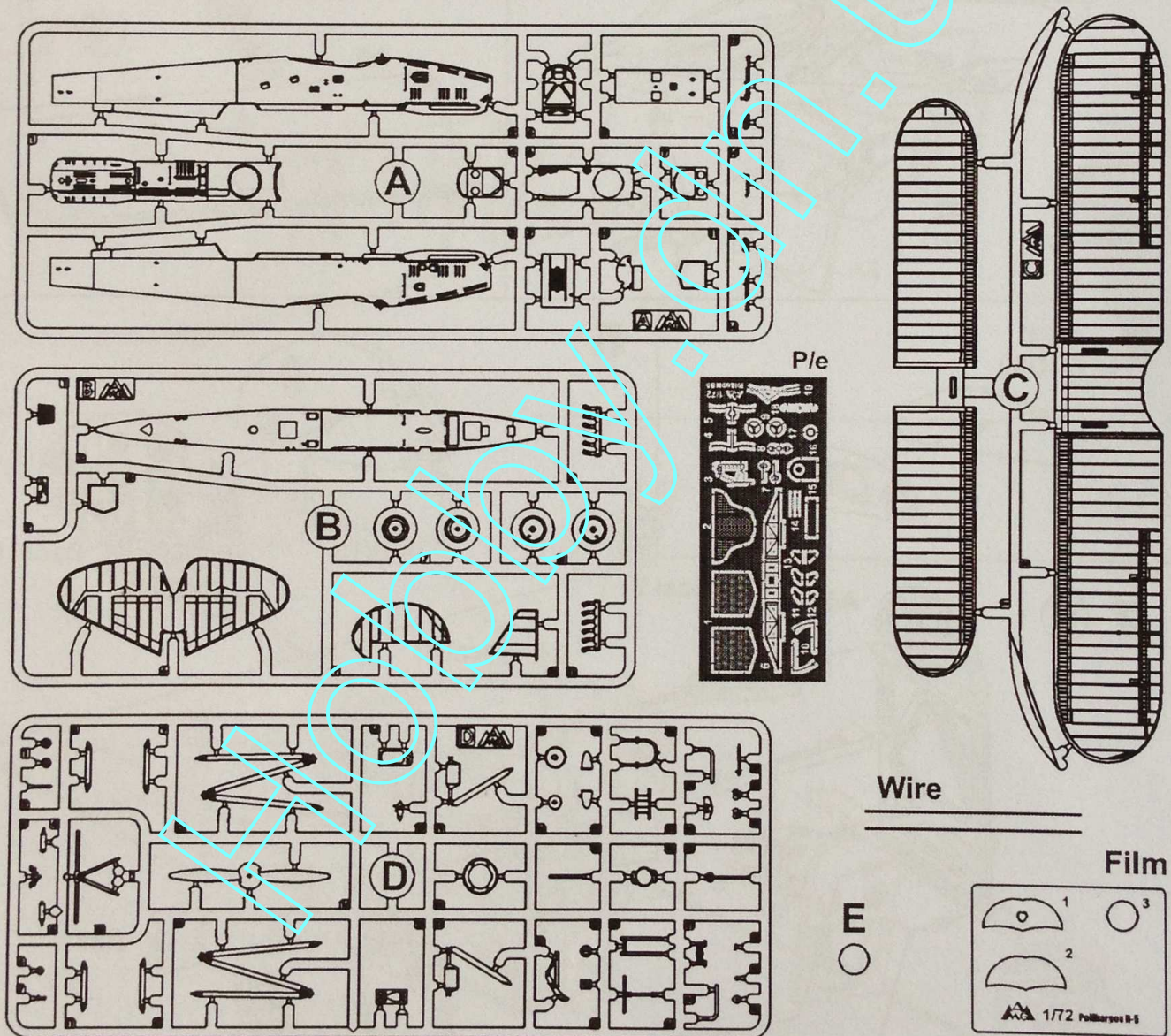

THE CONDITIONAL DENOTATION

УСЛОВНЫЕ ОБОЗНАЧЕНИЯ

 BE CAREFUL  
ОСТОРОЖНО

 DON'T CEMENT  
НЕ КЛЕИТЬ

 REMOVE  
РЕЗАТЬ

 SYMMETRICAL  
СИММЕТРИЧНО

 MAKE TWO  
УДВОИТЬ

 OPTIONAL  
НЕОБЯЗАТЕЛЬНО

 BEND  
СОГНУТЬ

 OPEN WHOLE  
СВЕРЛИТЬ

 CEMENT  
КЛЕИТЬ

 VARIANTS  
ВЫБОР ВАРИАНТА

Decal IV

1

Decal V

B1

P/e2 D33

Decal VI

2

D20

D29

A6

3

2

B2

D35

4

D41

A8

D40

5

D39

Decal X

6

A10

Decal IX

7

A5

Decal XI

Decal XI

D3

A7

A9

D37

D38

P/e16

8

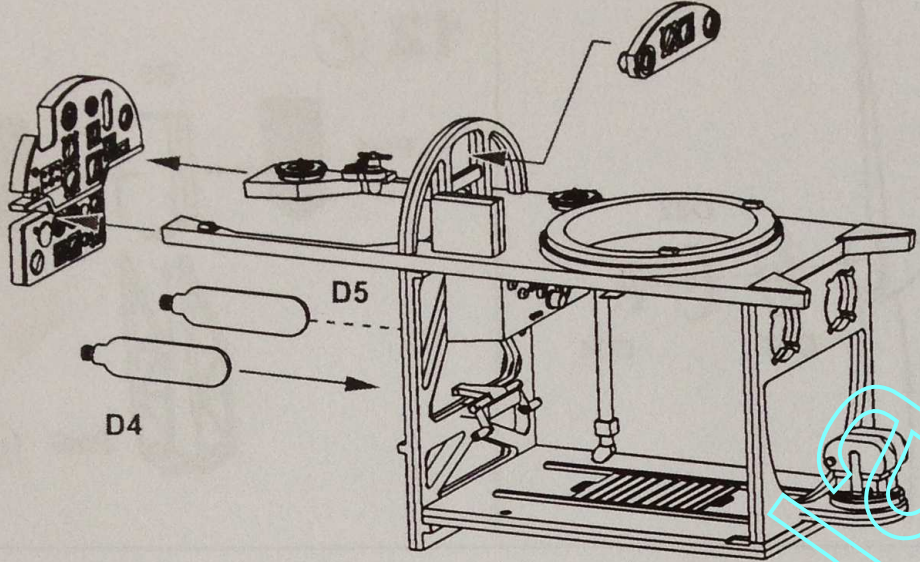

9

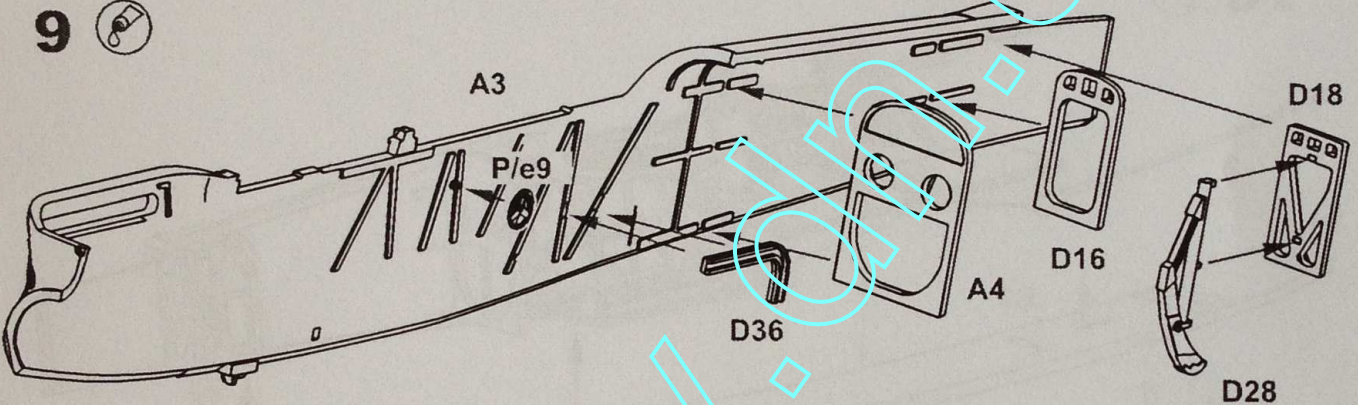

10

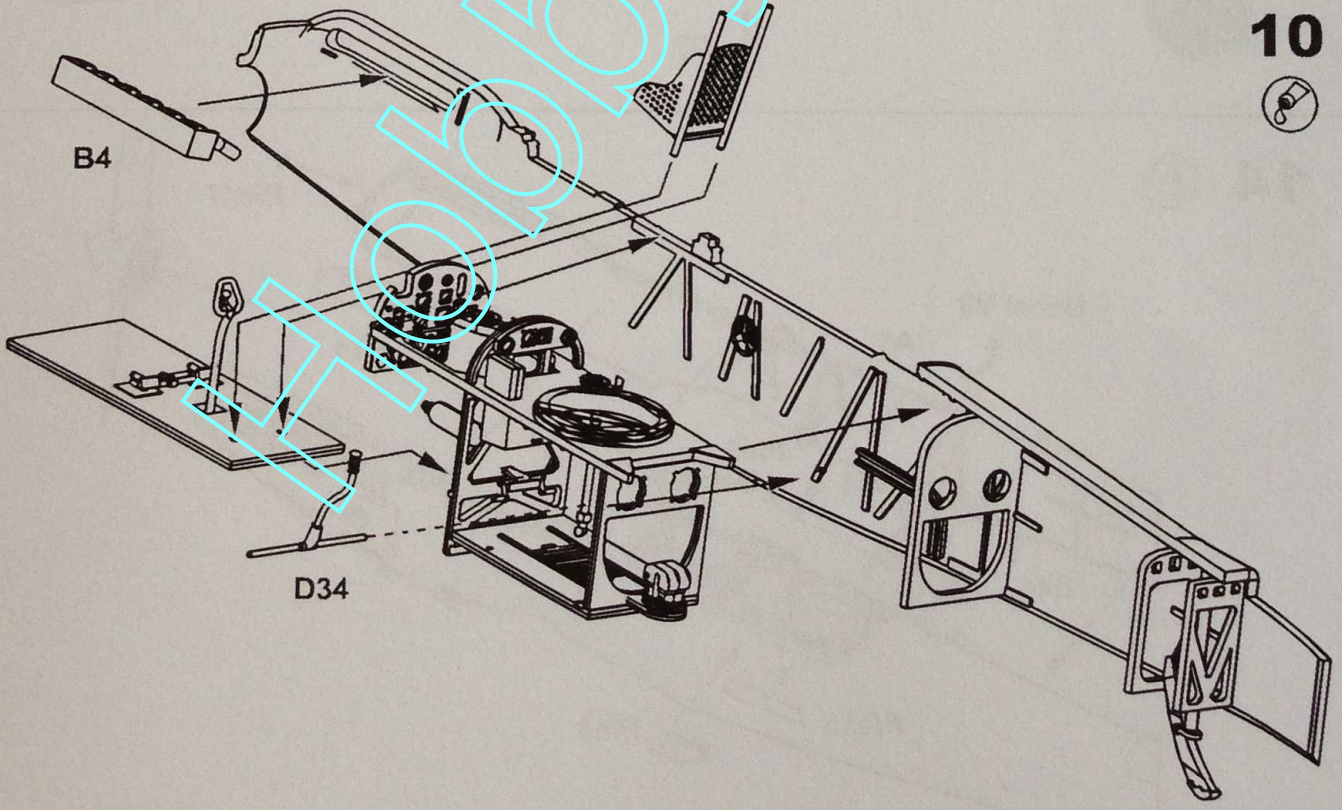

11

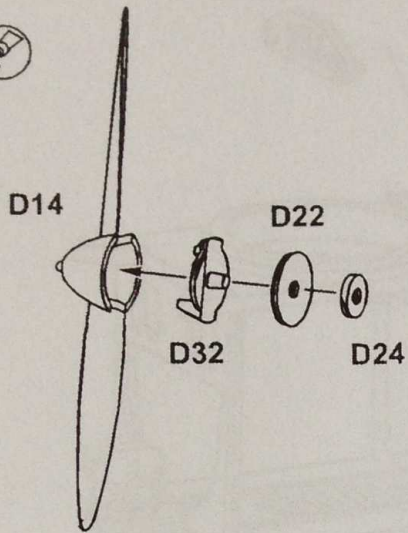

12

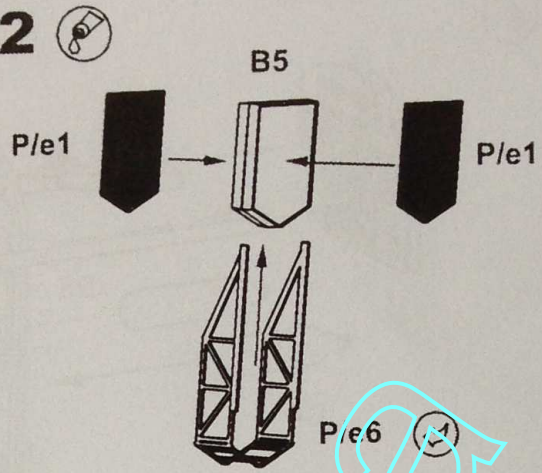

13

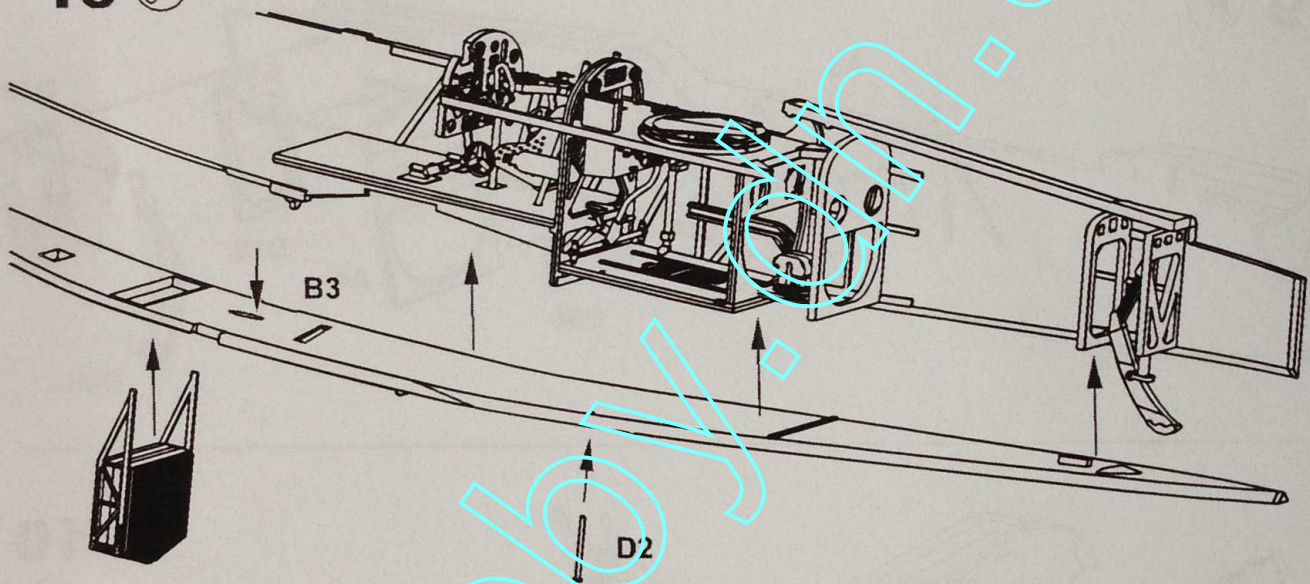

14

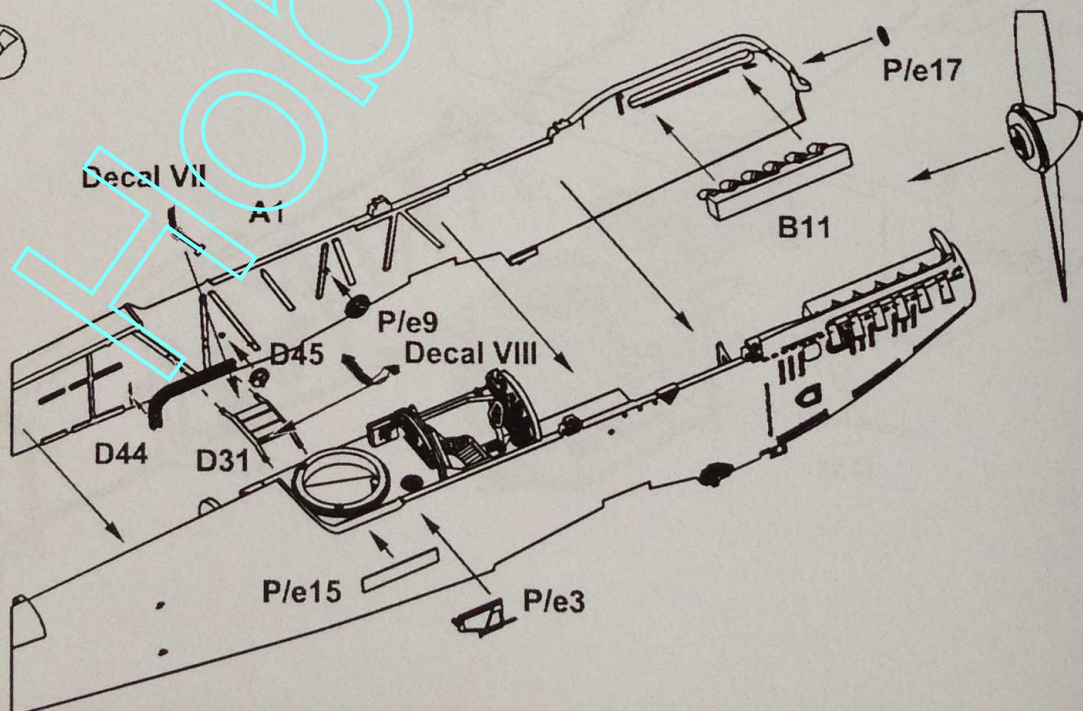

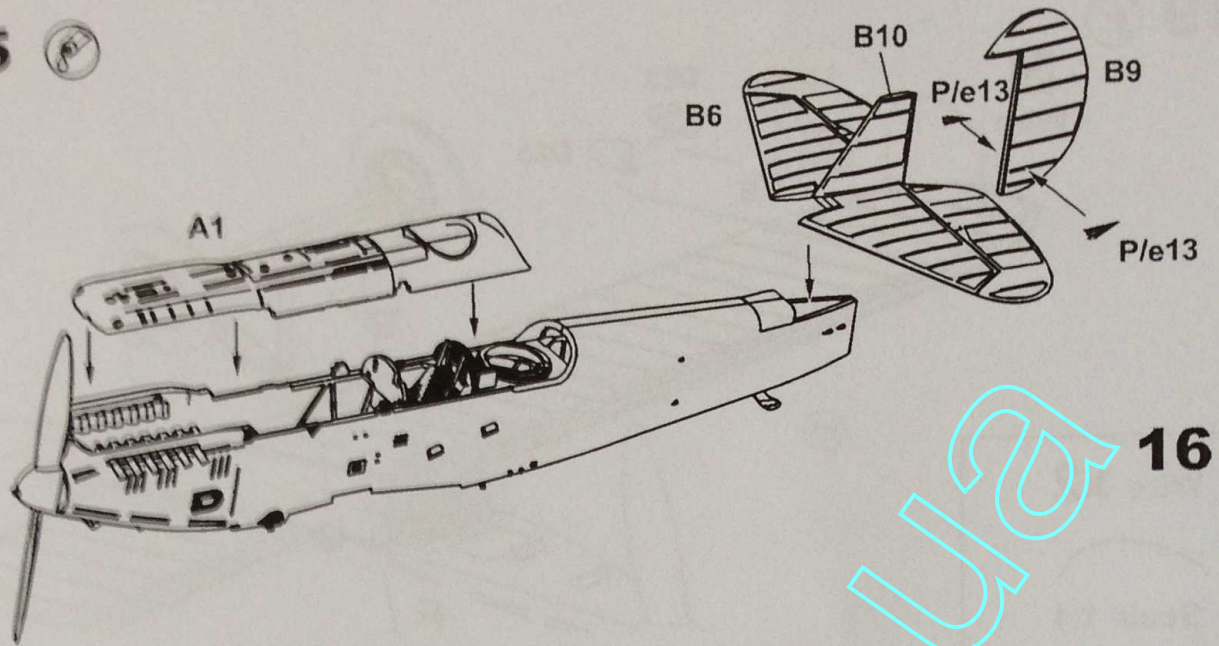

15 

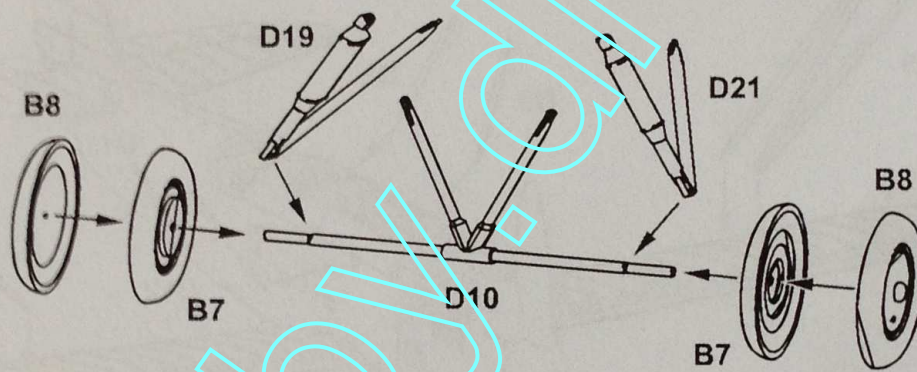

16

17 



18 

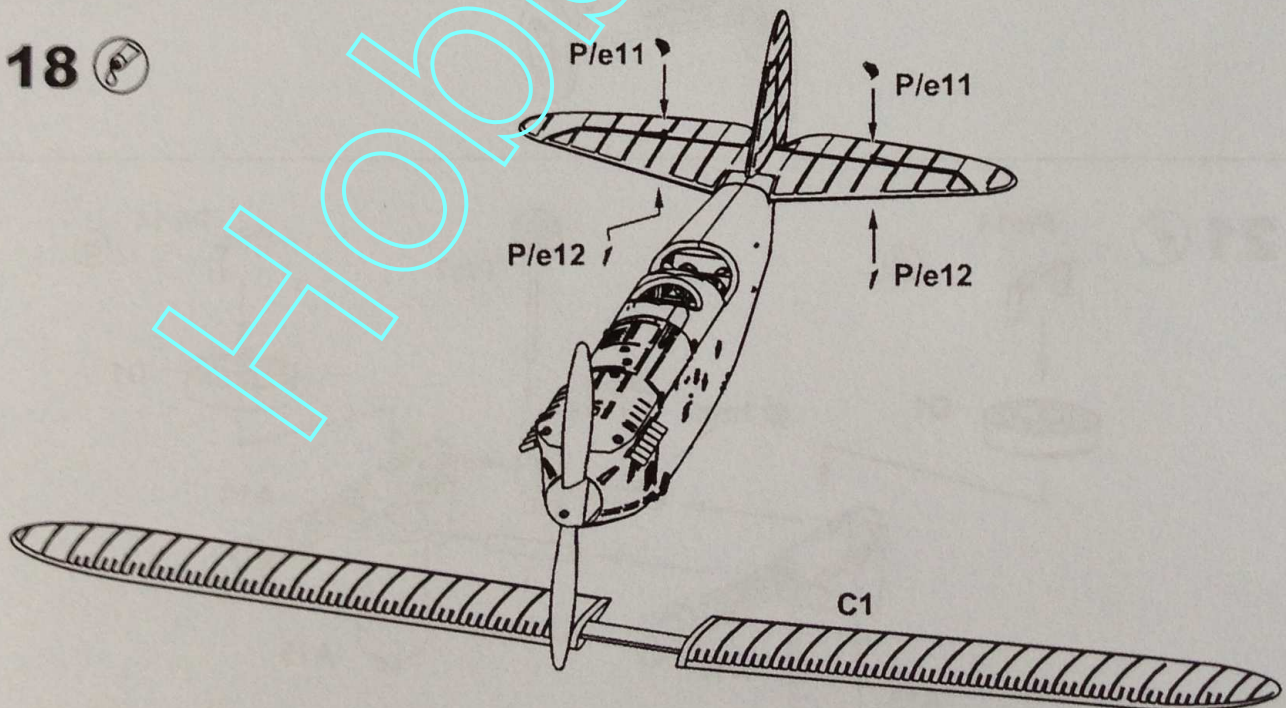

19

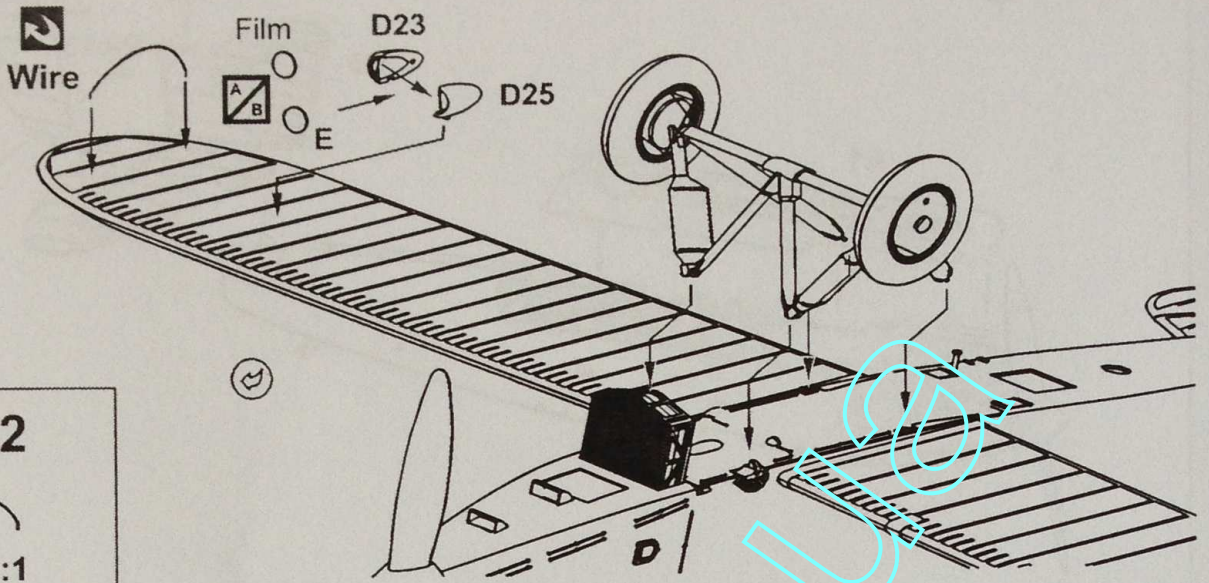

Wire X2

Scale 1:1

20

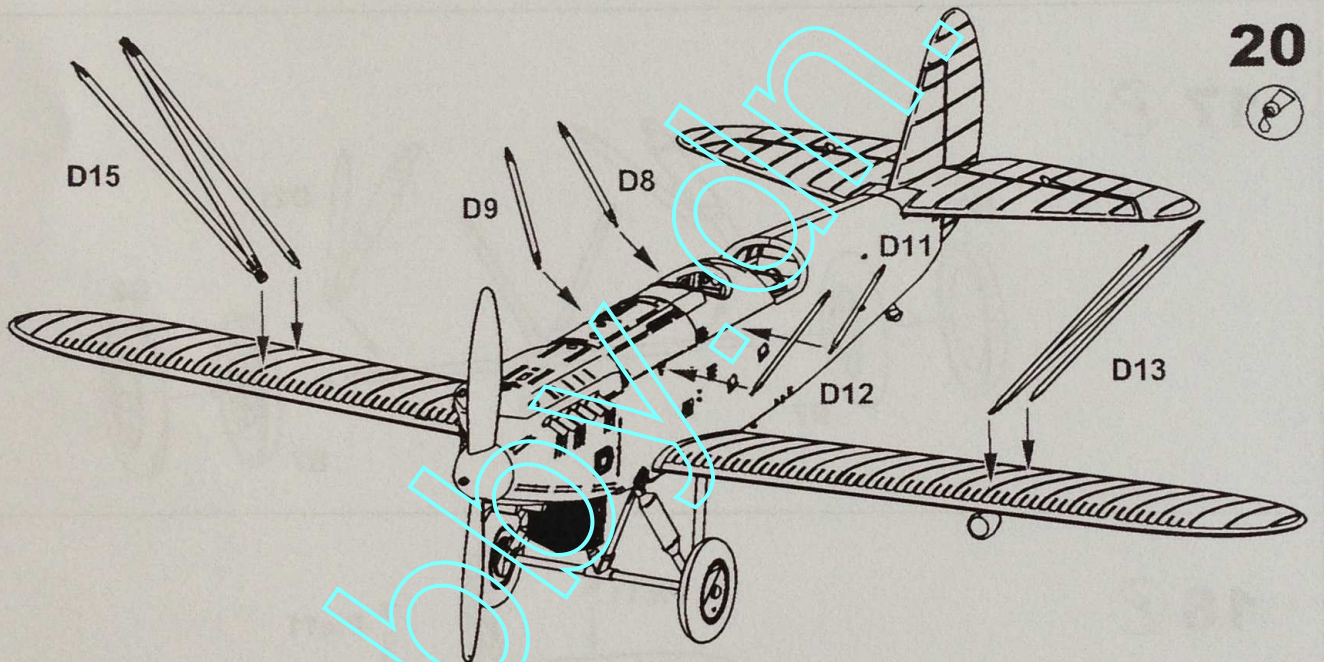

21

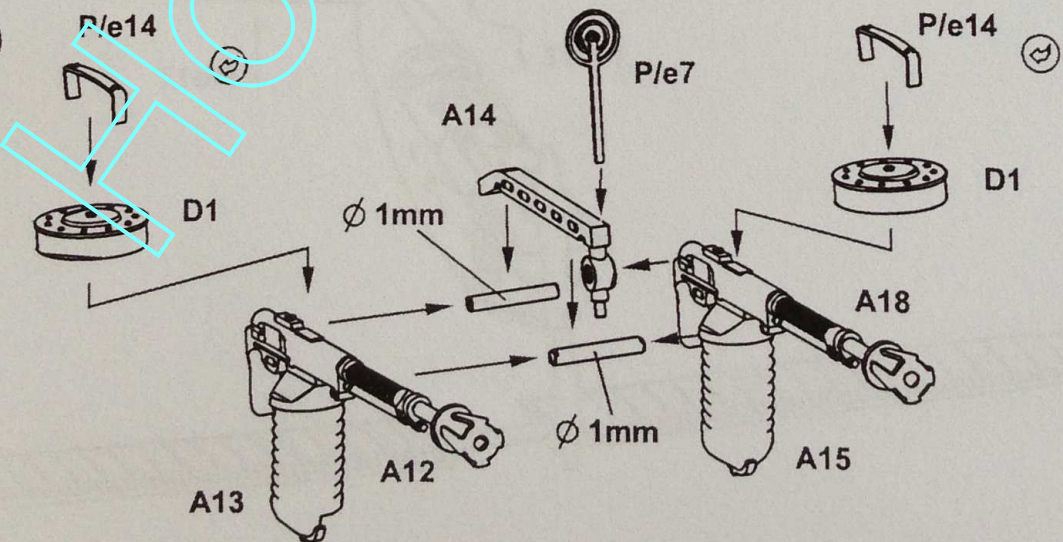

22

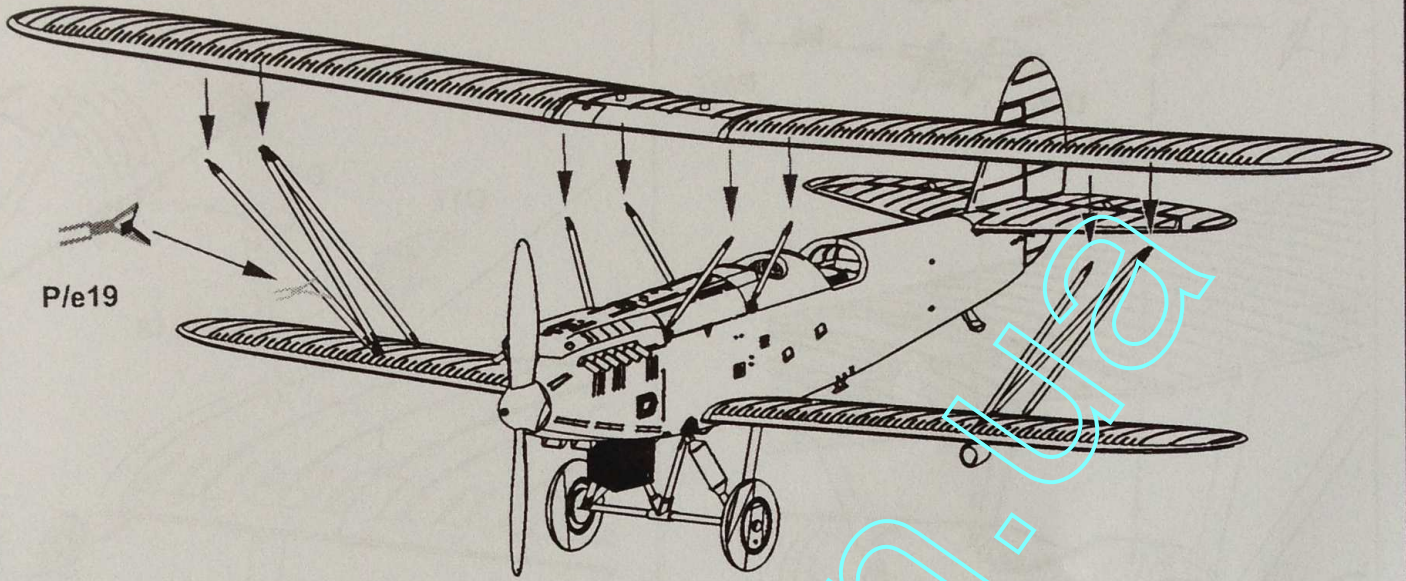

23

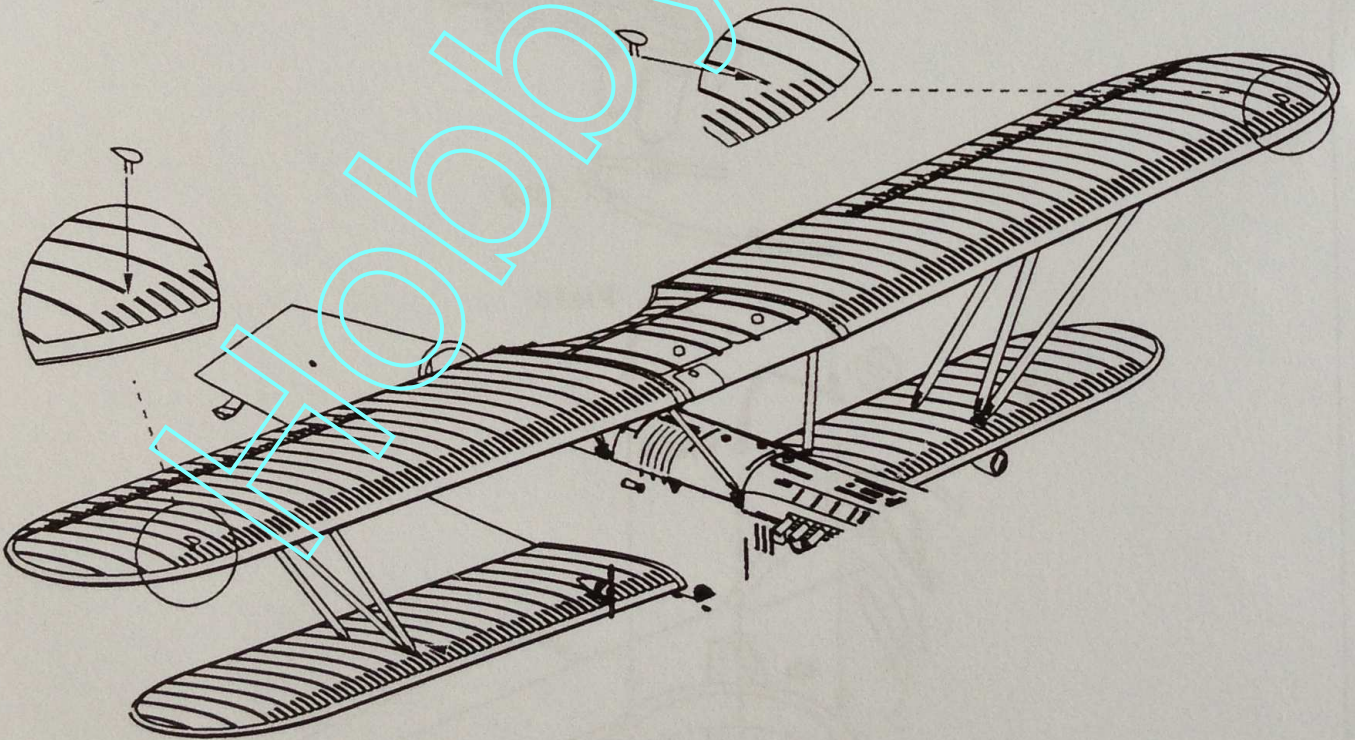

24

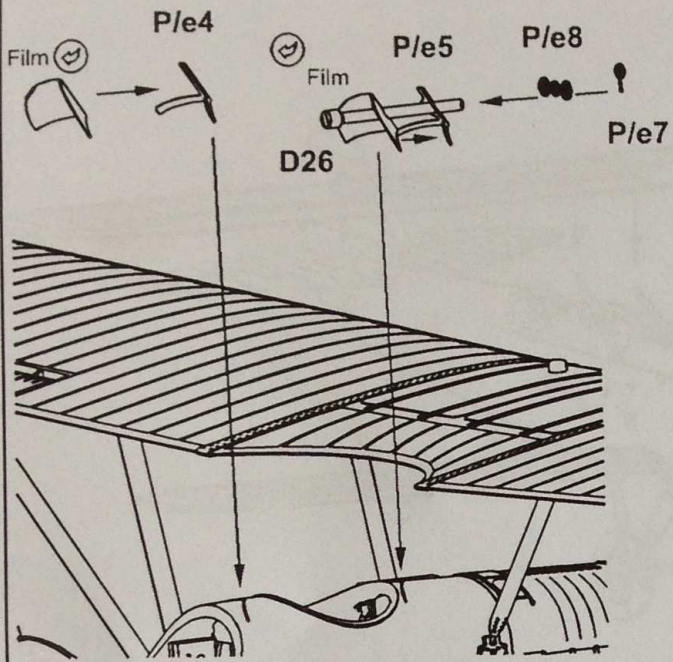

25

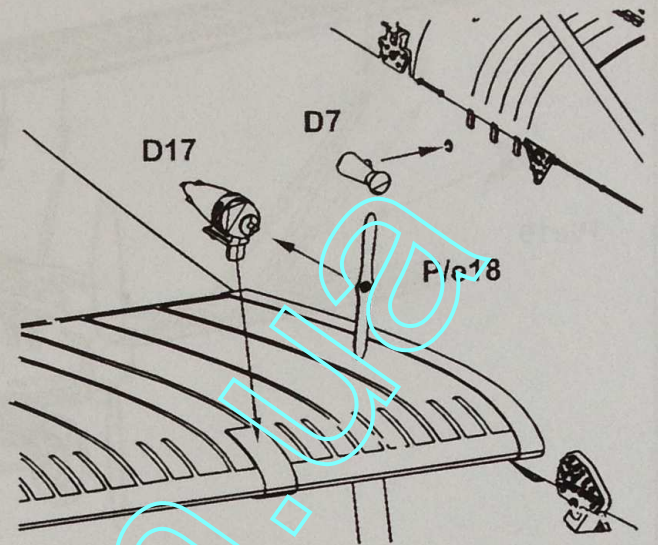

26

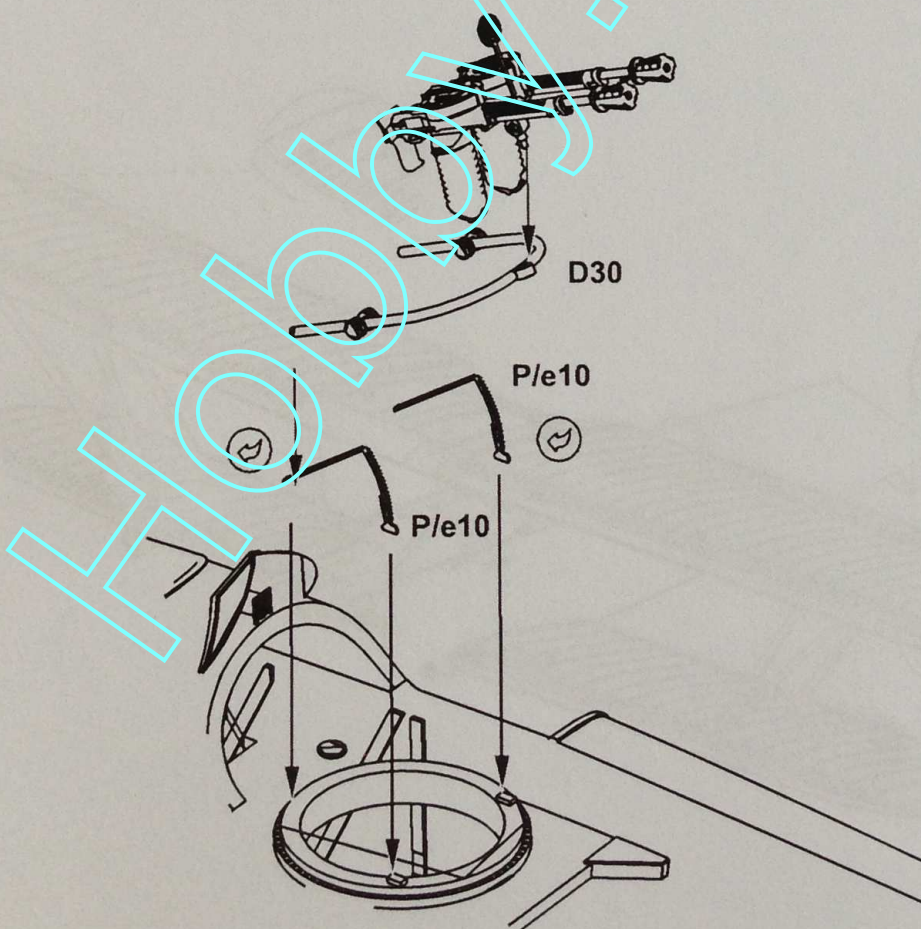



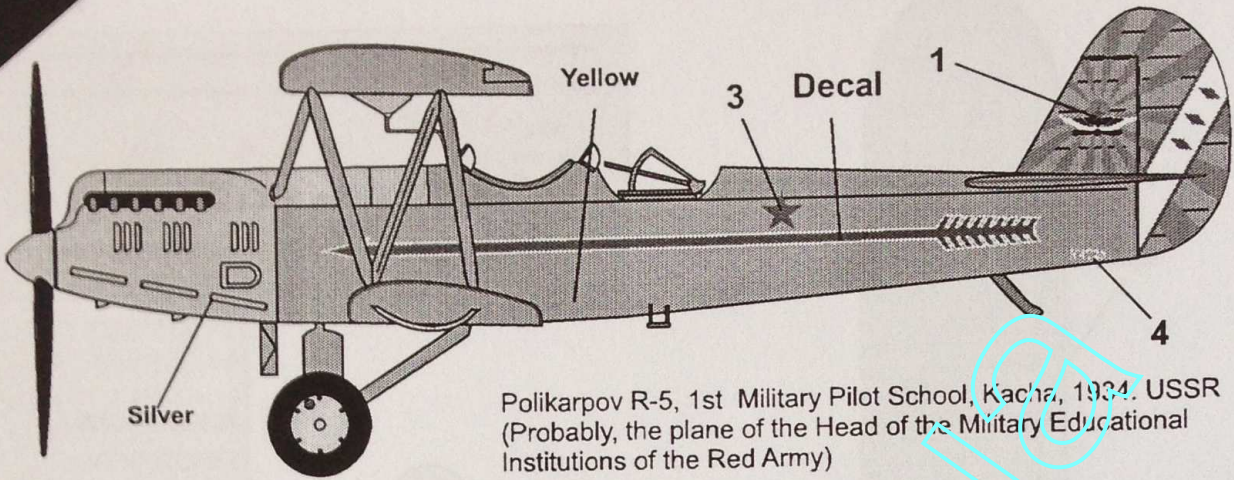

Polikarpov R-5, 1st Military Pilot School, Kacha, 1934. USSR  
(Probably, the plane of the Head of the Military Educational  
Institutions of the Red Army)

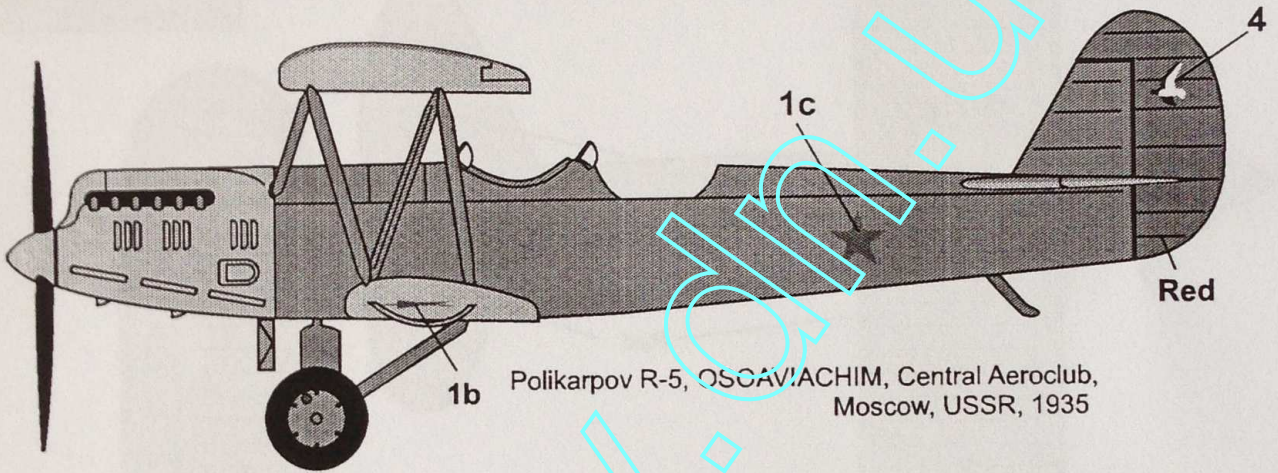

1b Polikarpov R-5, OSCAV/ACHIM, Central Aeroclub,  
Moscow, USSR, 1935

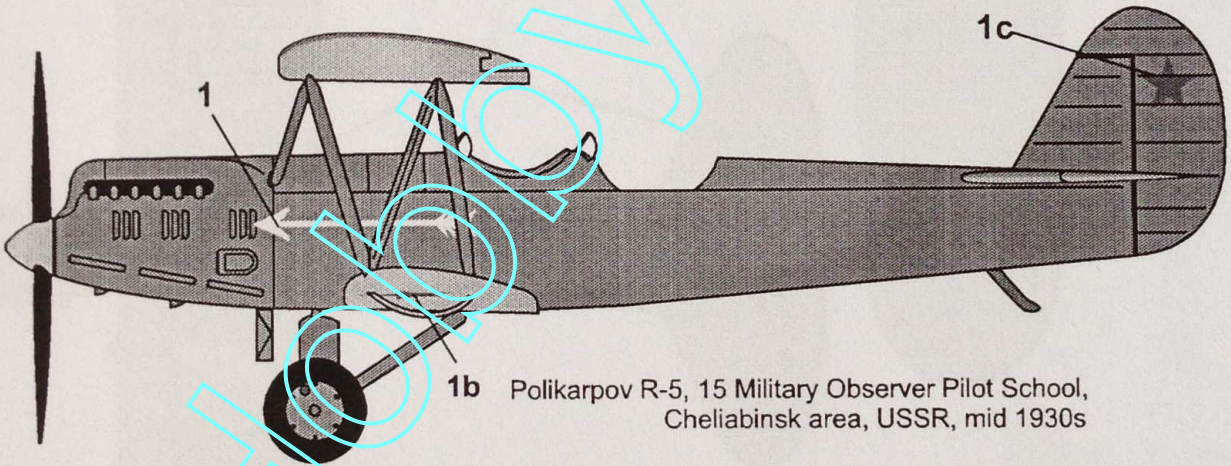



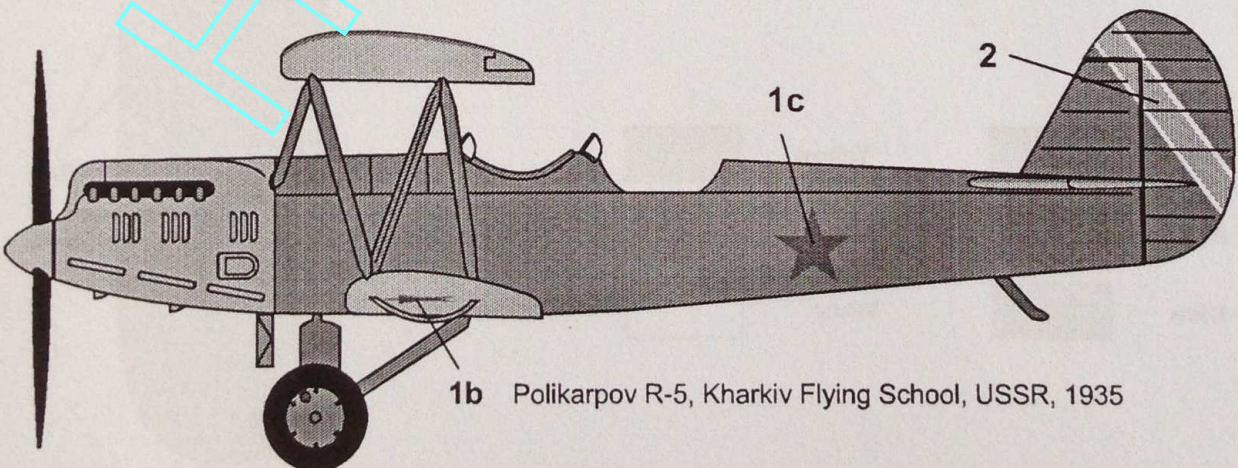

1b Polikarpov R-5, 15 Military Observer Pilot School,  
Cheliabinsk area, USSR, mid 1930s

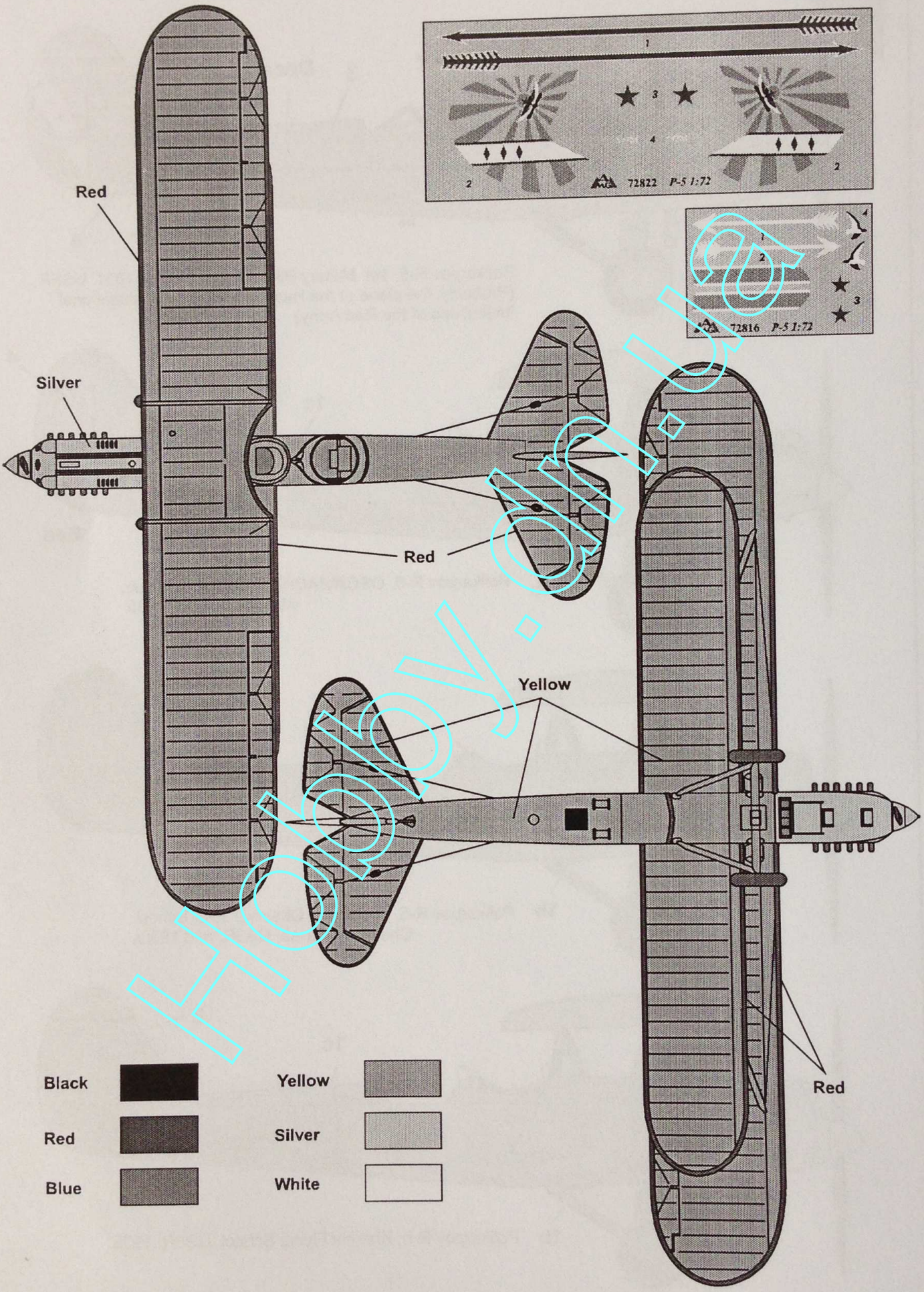

1b Polikarpov R-5, Kharkiv Flying School, USSR, 1935

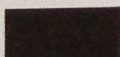
Decals



Black		Yellow	
Red		Silver	
Blue		White	