

PLASTIC MODEL KITS
LIMITED EDITION
CAT.NO.72383

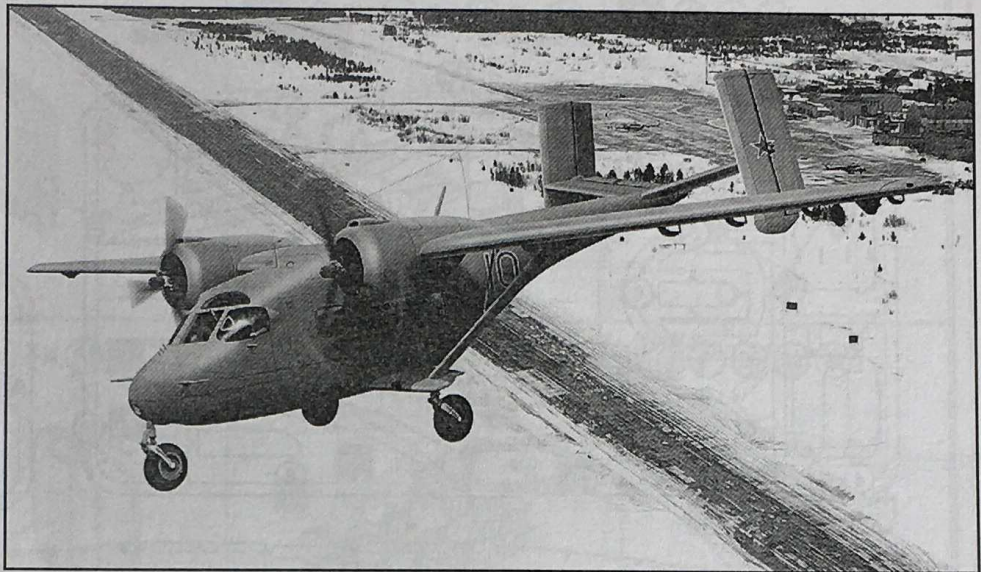

SPAN : 306 mm
LENGTH : 158 mm
PARTS : 237 pieces
SCALE:1/72



An-14 "Pchelka" (Small Bee) (according to NATO codification "Clod") - Soviet transport turboprop designed to be a substitute of An-2. The first flight was 14 March 1958.

An-14 - all-metal piston two engines strut-framed high plane with twin-fill tail, fixed landing gear, and tail cargo-and-passenger door. This short takeoff and landing aircraft can be used on unequipped and unpaved airfields. Batch production began in 1966. There were built 340 airplanes.

The model is executed on technology short run and is intended only for experienced modelers

World-wide distributor for AMODEL kits: IBG, Warszawa, Poland
Fax: (4822) 842-56-29; E-Mail: ibgsc@ibg.com.pl



USED SYMBOLS



1 STAGES OF ASSEMBLY



1 NUMBER PARTS



APPLY DECALS



TO PAINT



GLUE



DON'T GLUE



OPTIONAL



TO BEND



TO USE SUPERGLUE™



2x QUANTITY OF OPERATIONS(PARTS)



USED PAINTS



HUMBROL 145
MEDIUM GREY



HUMBROL 102
ARMY GREEN



HUMBROL 26
KHAKI



HUMBROL 64
LIGHT GREY



HUMBROL 24
YELLOW



HUMBROL 11
SILVER



HUMBROL 53
GUNMETAL



HUMBROL 33
BLACK



HUMBROL 56
ALUMINIUM



HUMBROL 65
LIGHT BLUE



HUMBROL 23
DUCK EGG BLUE



HUMBROL 162
SURFACE GREY



HUMBROL 121
PALE STONE



HUMBROL 101
MID GREEN



HUMBROL 19
RED



HUMBROL 89
MIDDLE BLUE



DECALS

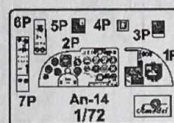
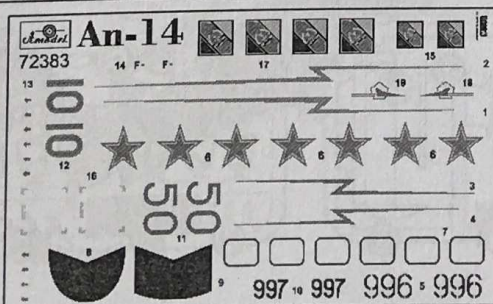

MASKS FOR PAINTING

DECALS FOR FOUR VERSIONS OF COLOURING

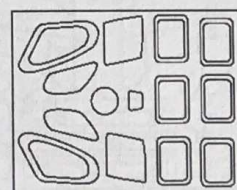



COMPLETE SET

237 DETAILS FOR ASSEMBLY OF ONE MODEL

 PARTS NOT FOR USE

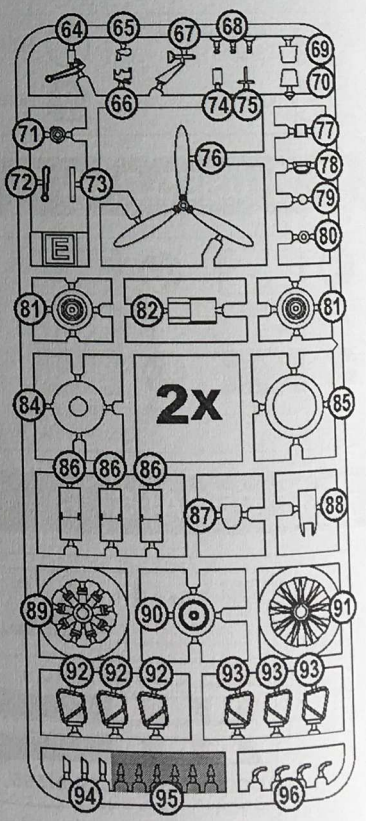
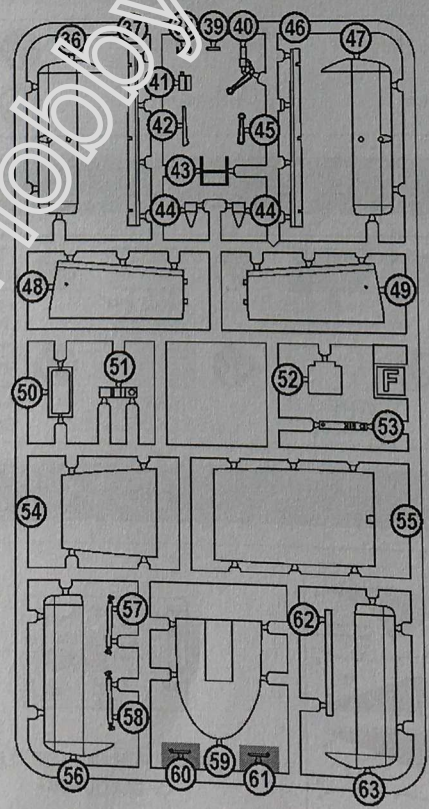
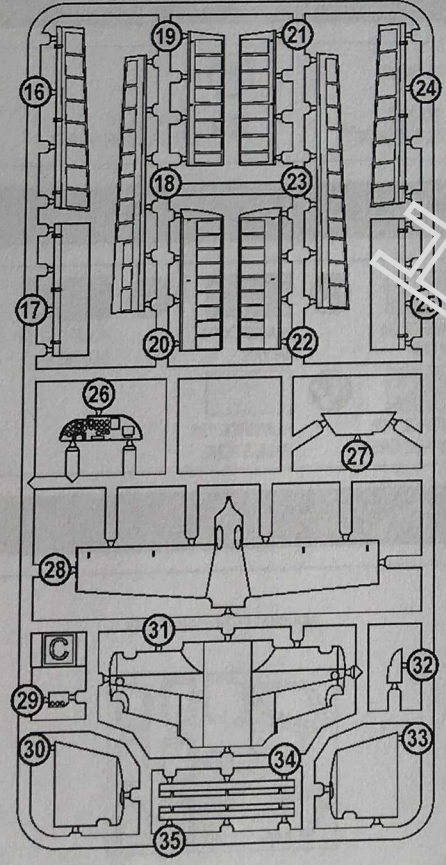
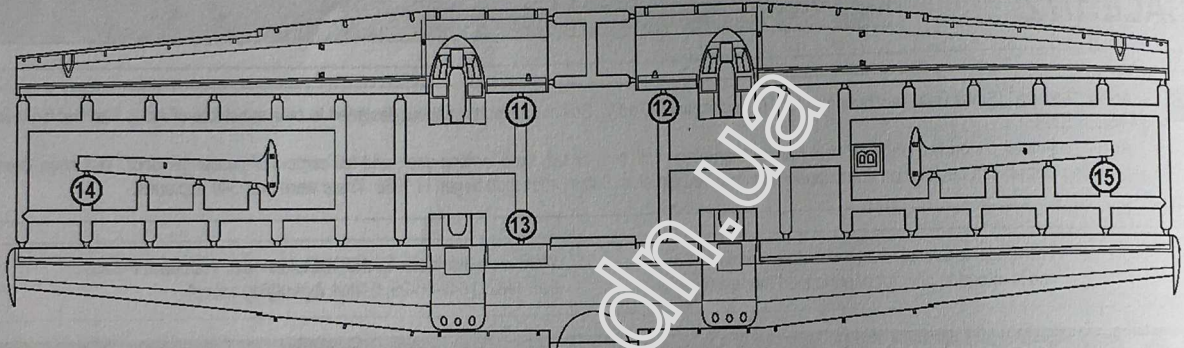
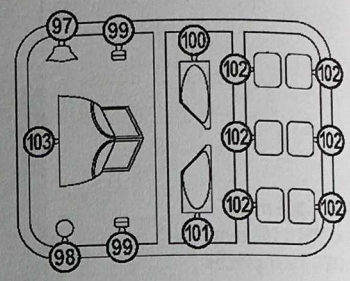
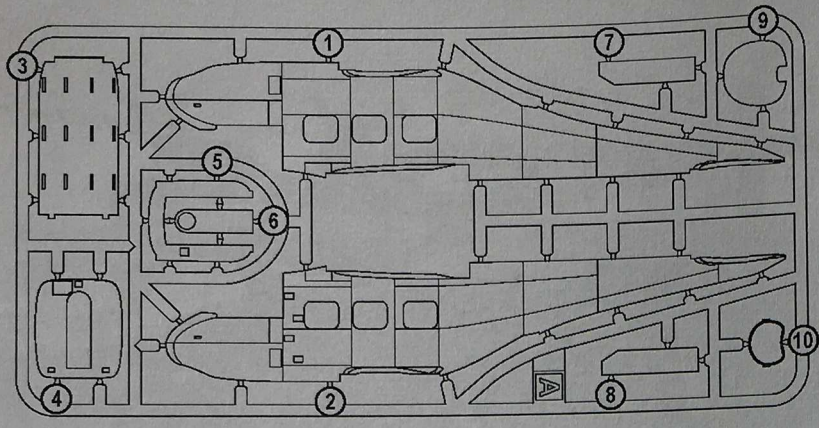
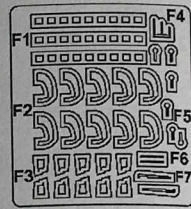

2x

1 4 6 29 98

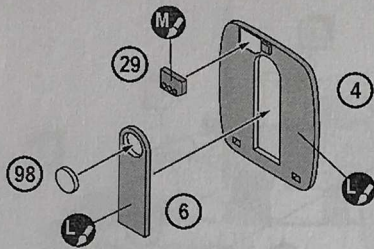

2 6x 86 6x 92 6x 93
6x

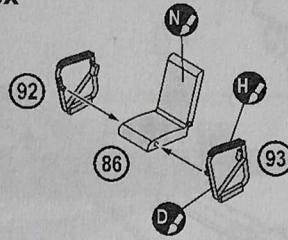

3 5 41

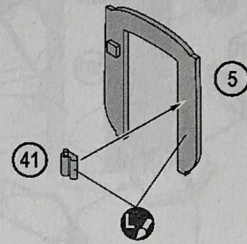

4 51 52 53 59 2x 82 5x F5 1

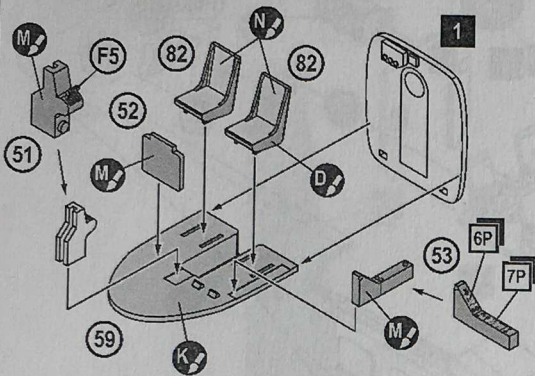

5 3 6x 2

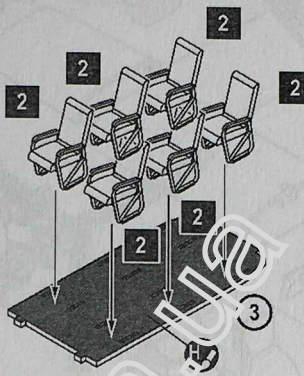

6 26 38 39

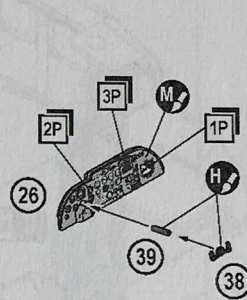

7 2 3x 102

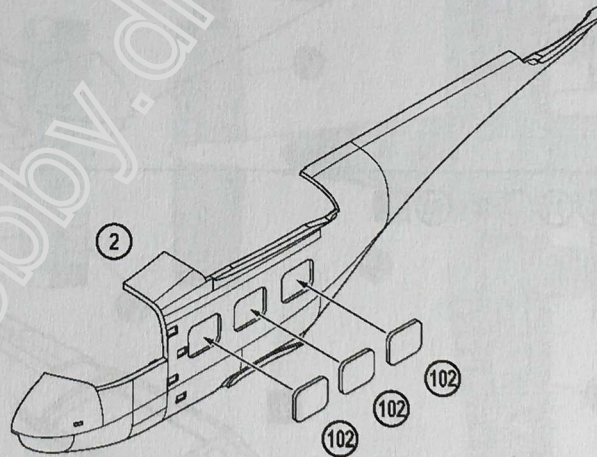
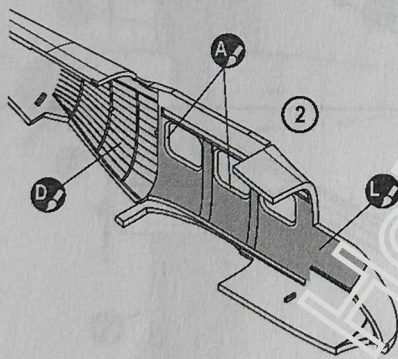

8 1 3x 102

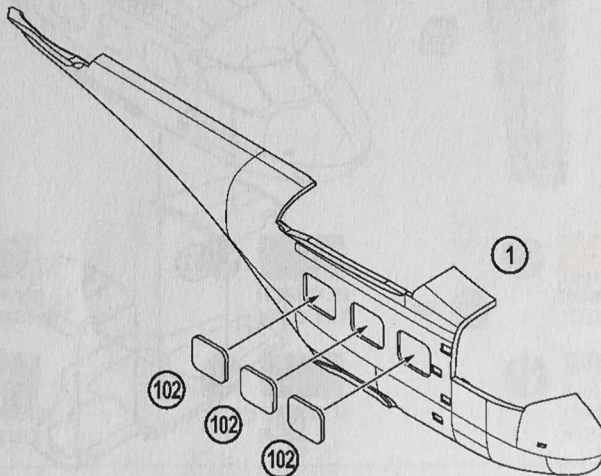
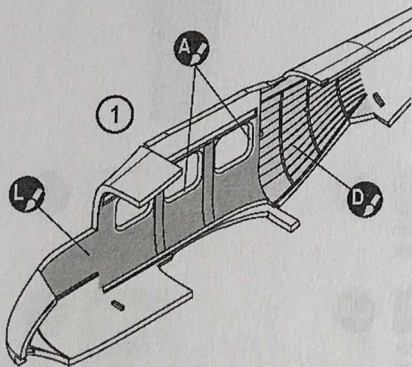

9 9 10 27 32 43 50 54 55 62 97 100 101 103 2x F6 3 4 5 6 7 8

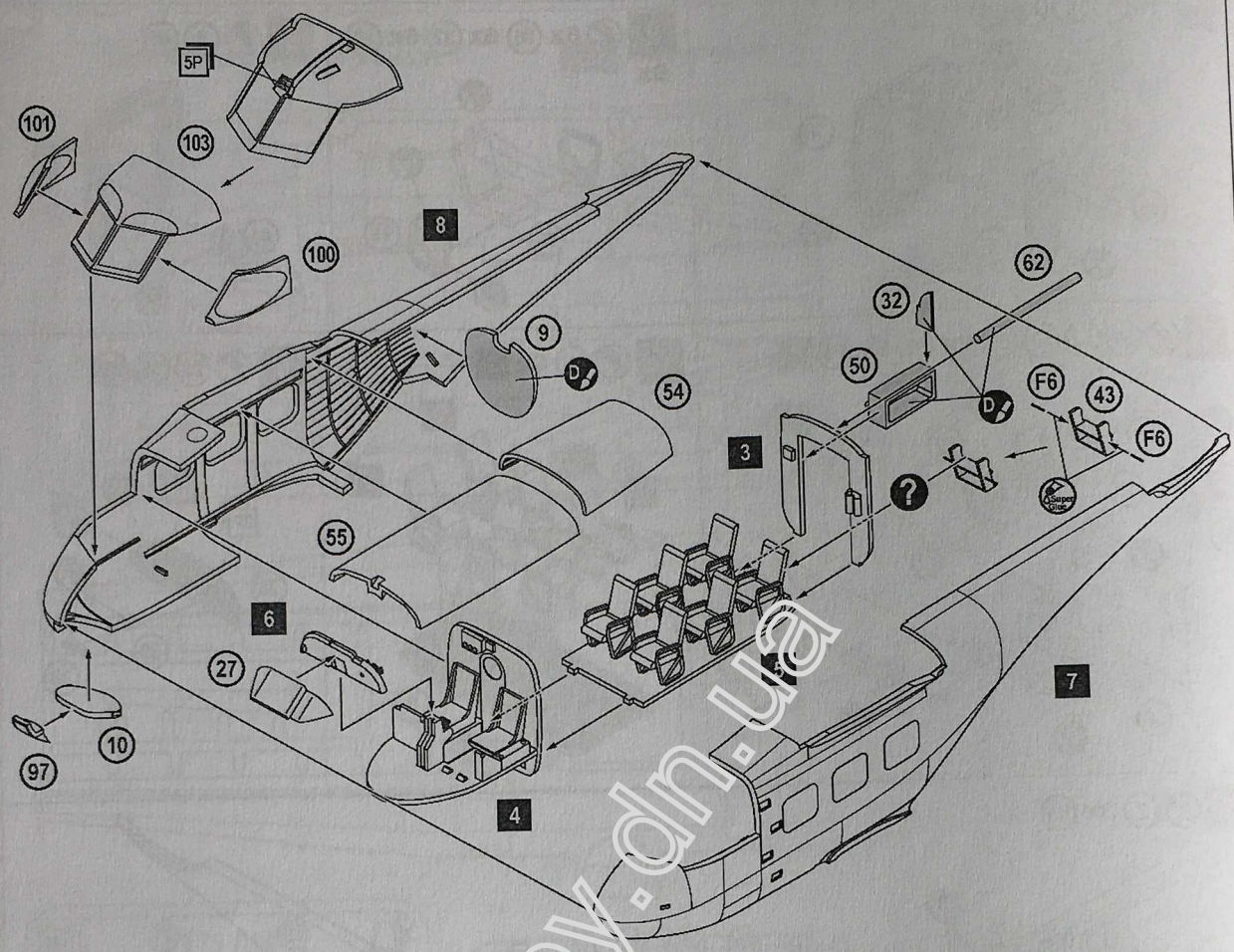

10 30 31 32 2x 99 9

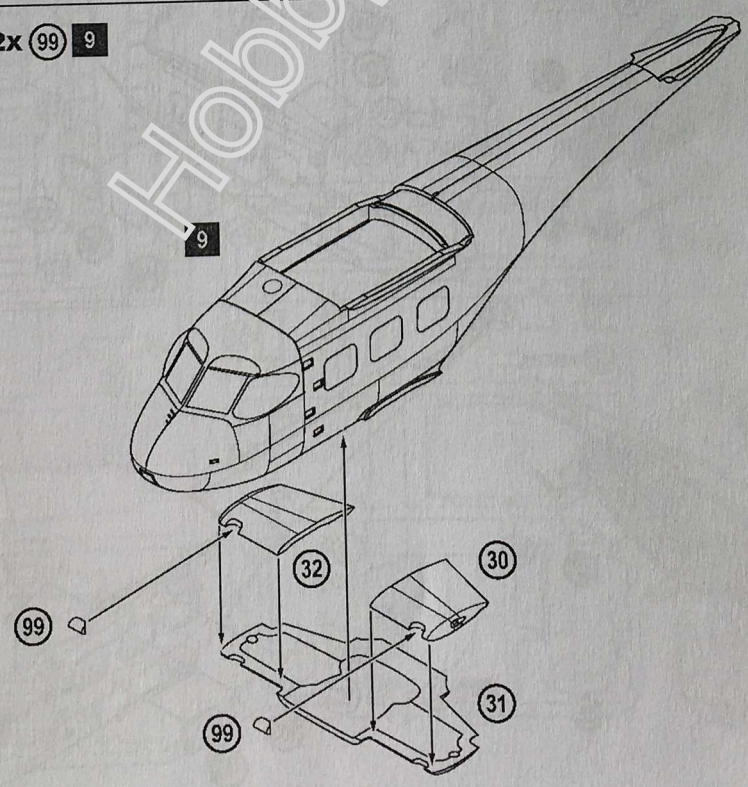

11  11 12 13 14 15 57 58 2x 69 2x 70 2x 84 10

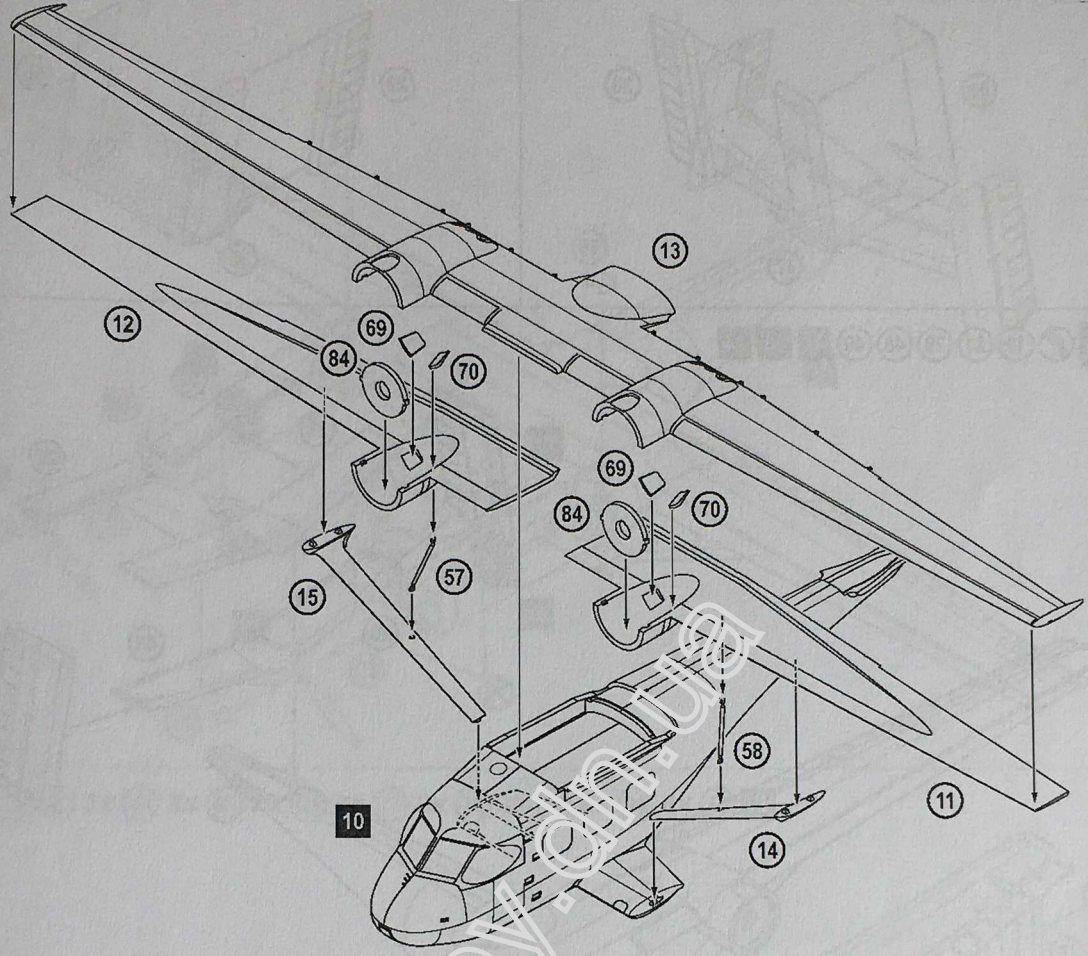

12  16 17 18 23 24 25 34 35 37 46 11

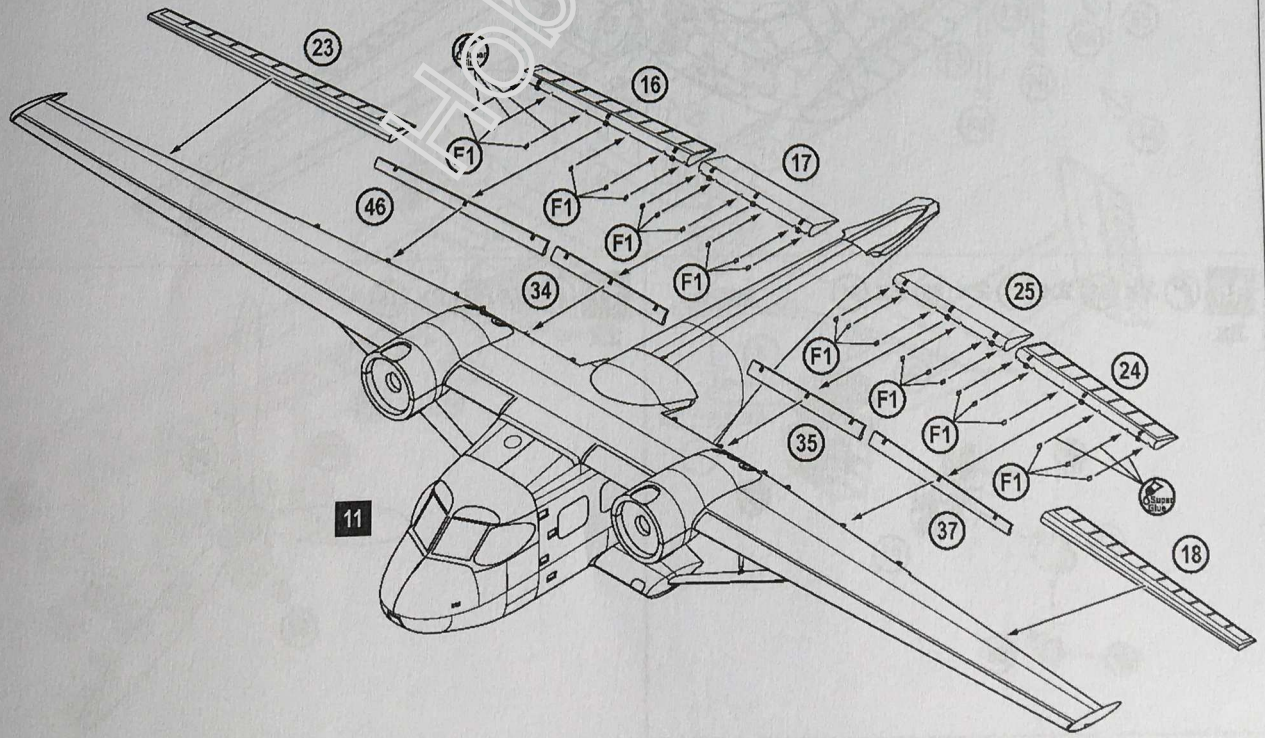

13 (63) (20) (47) (63)

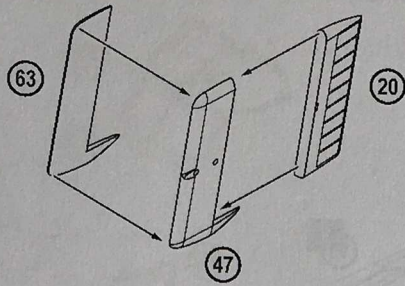

14 (22) (36) (56)

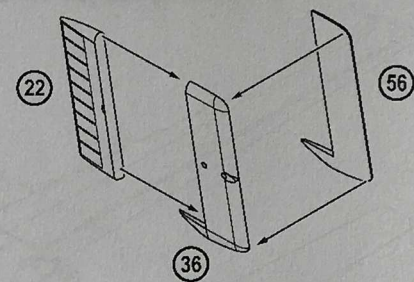

15 (19) (21) (28) (48) (49) (12) (13) (14)

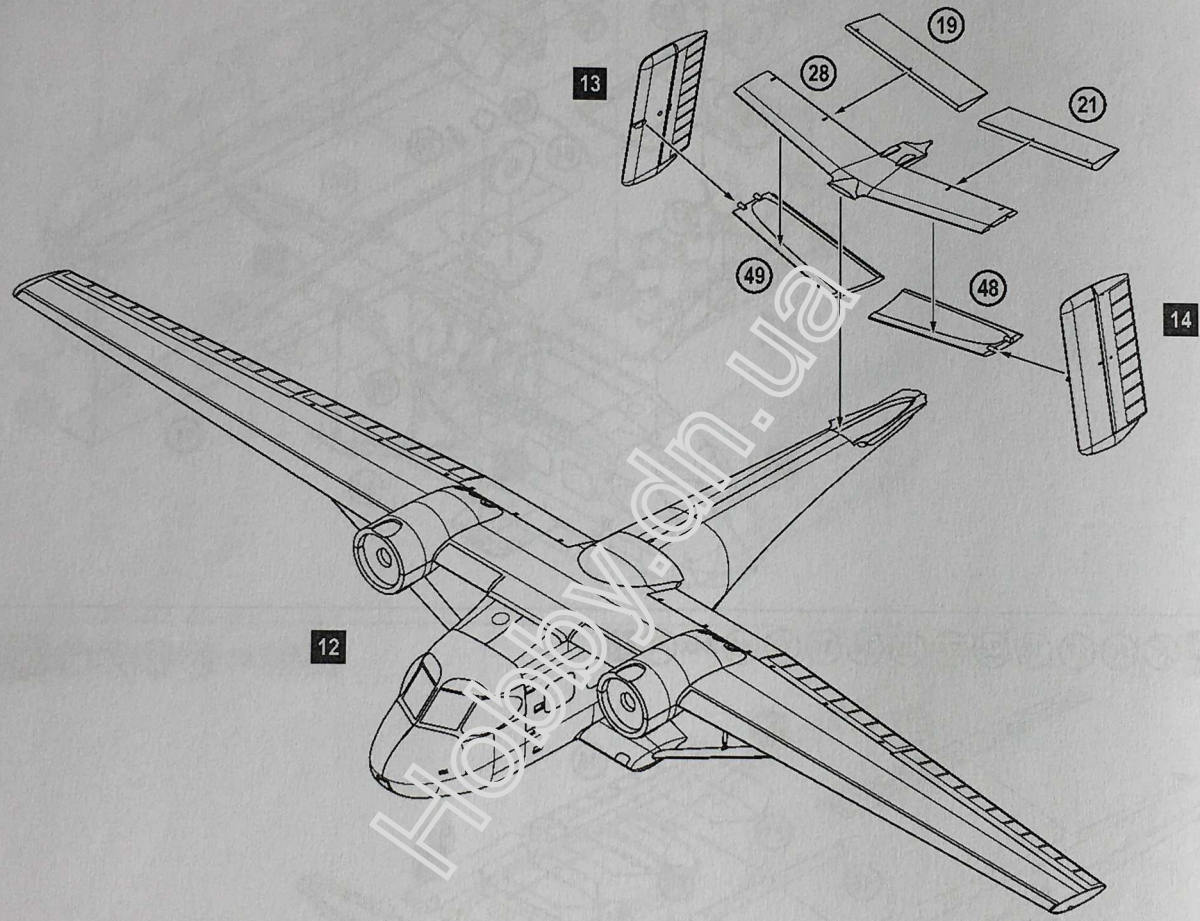

16 2x (66) 2x (71) 2x (89) 2x (91)
2x

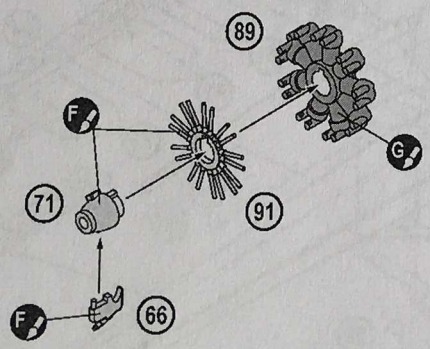

17 6x (68) 2x (76)
2x

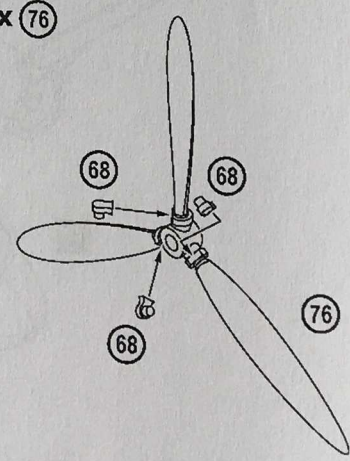

18 2x 73 2x 79 2x 80 2x 85 2x 87 15 2x 16 2x 17

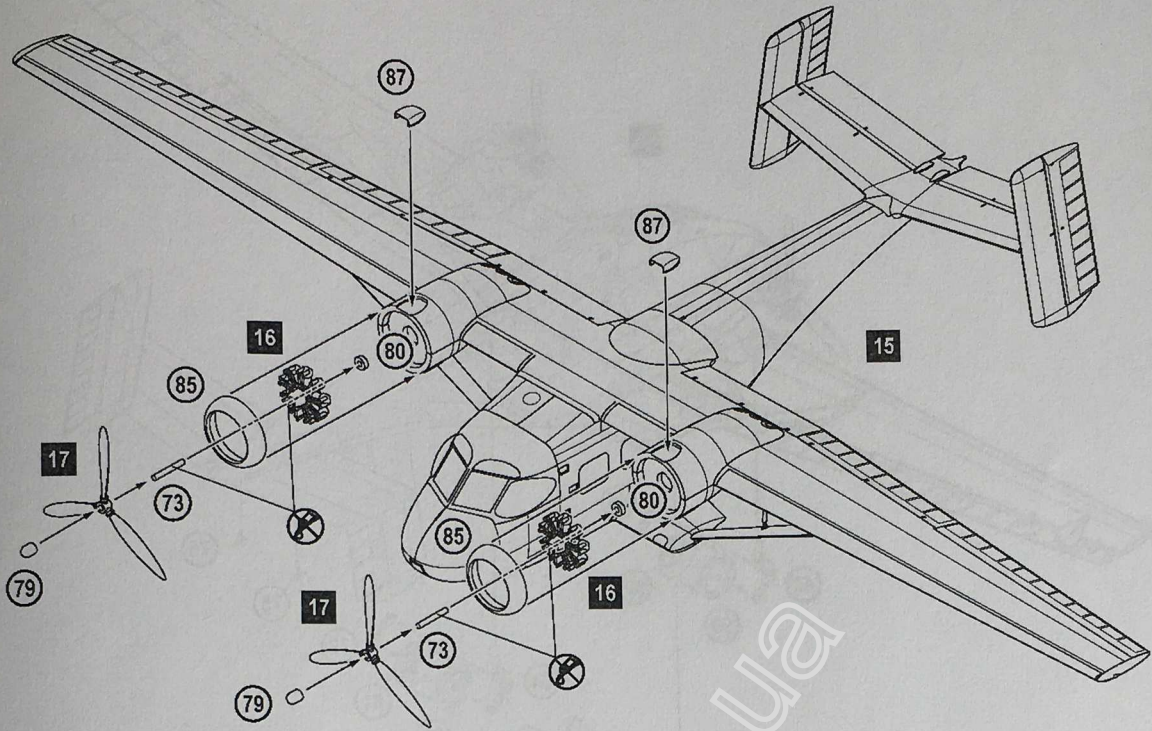

19 7 8 2x 44 2x 65 2x 74 2x 77 2x 78 2x 88 3x 96 3x F3 18

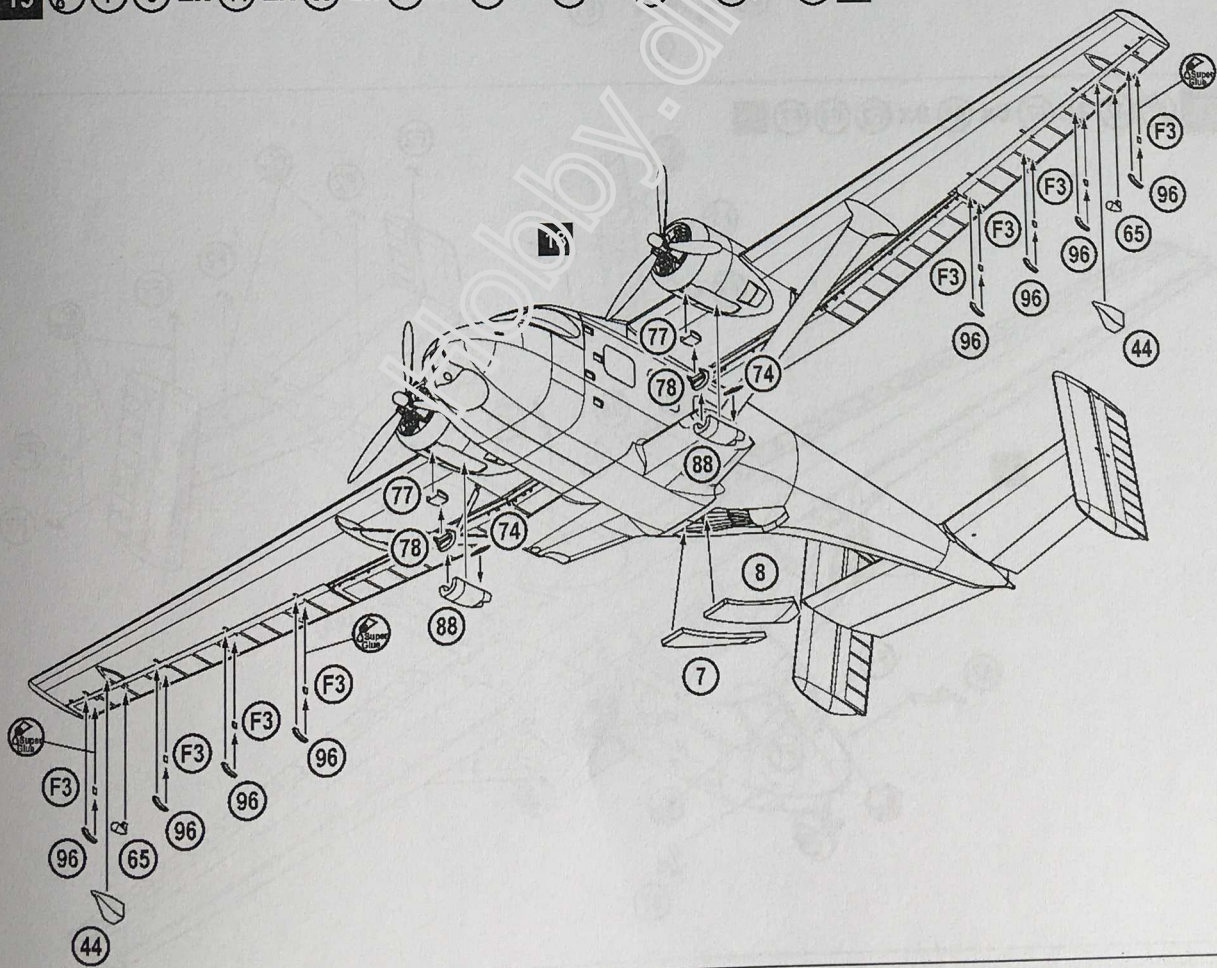

20  40 45 2x 64 2x 72 2x 75 4x 81 2x 90 19

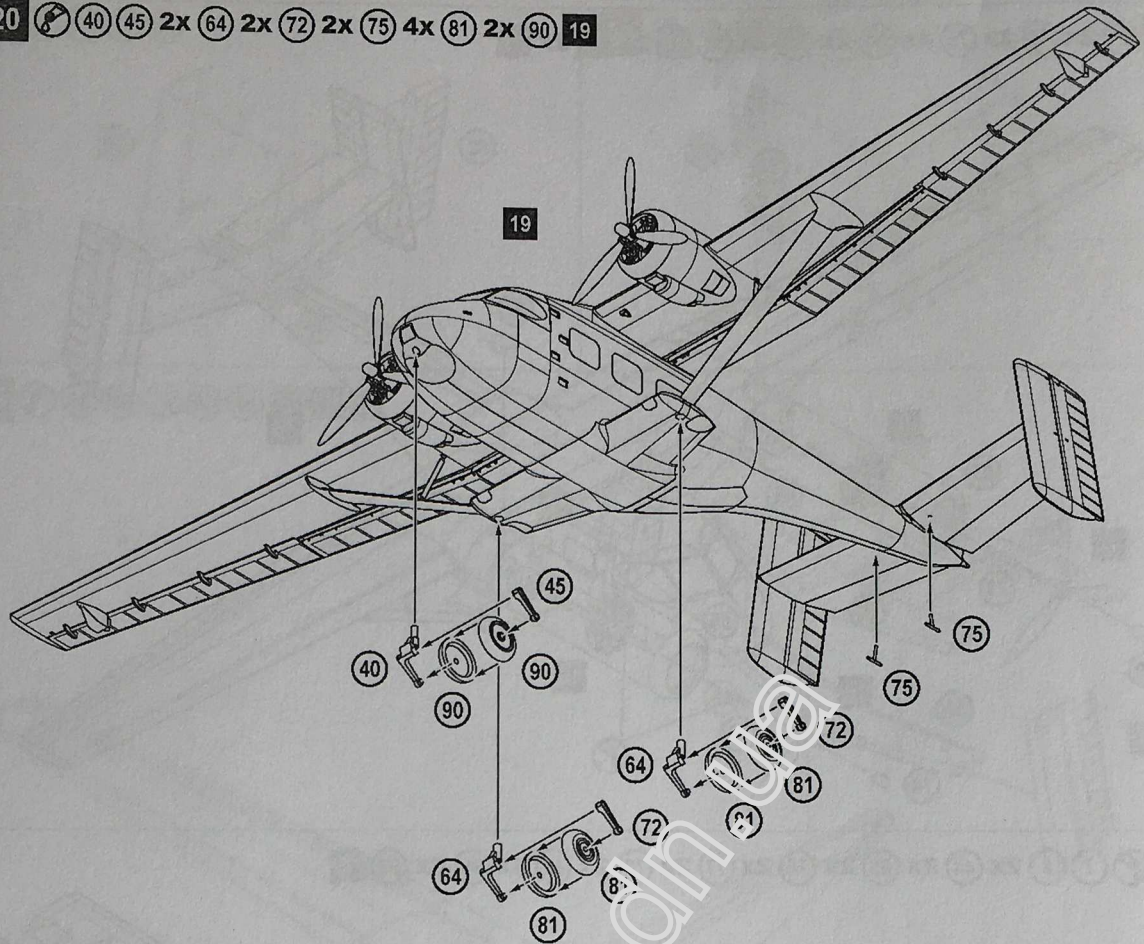

21  42 2x 67 6x 94 8x F2 F4 F7 20

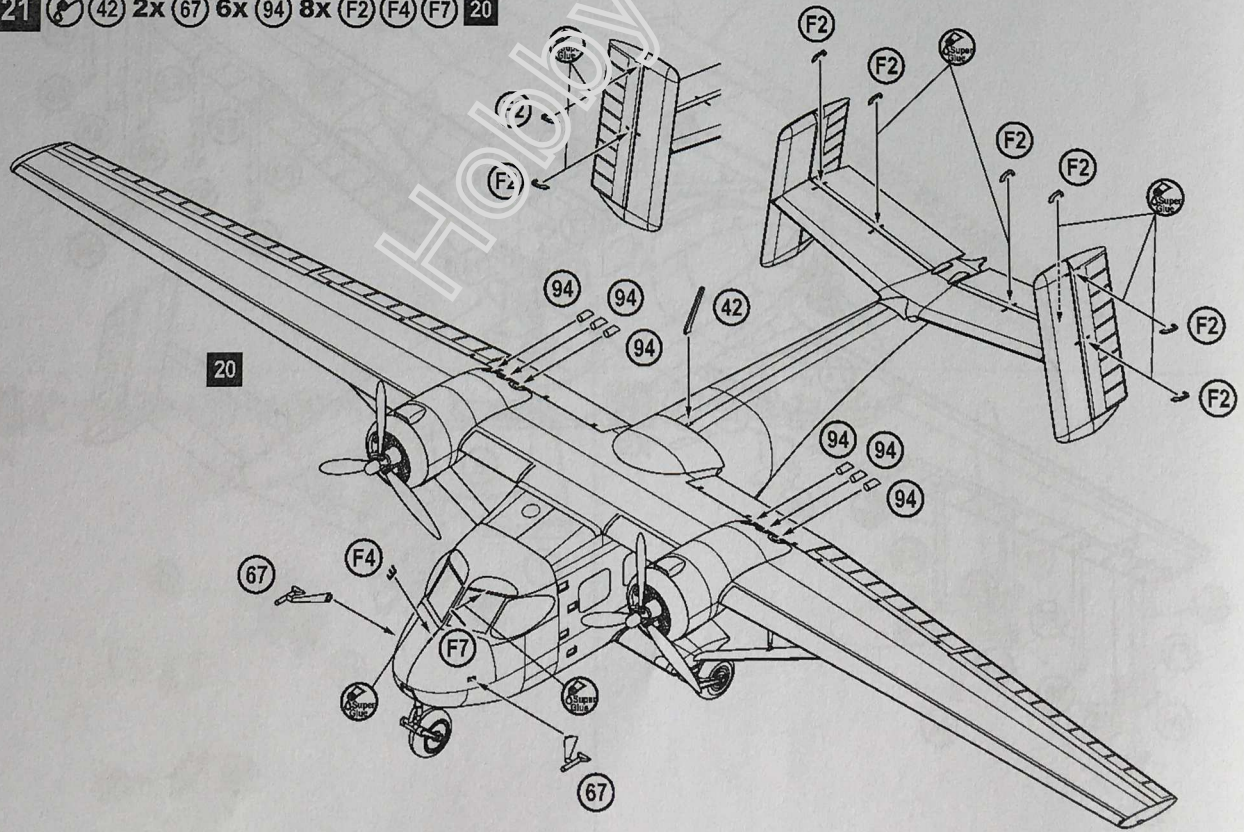

Antonov An-14

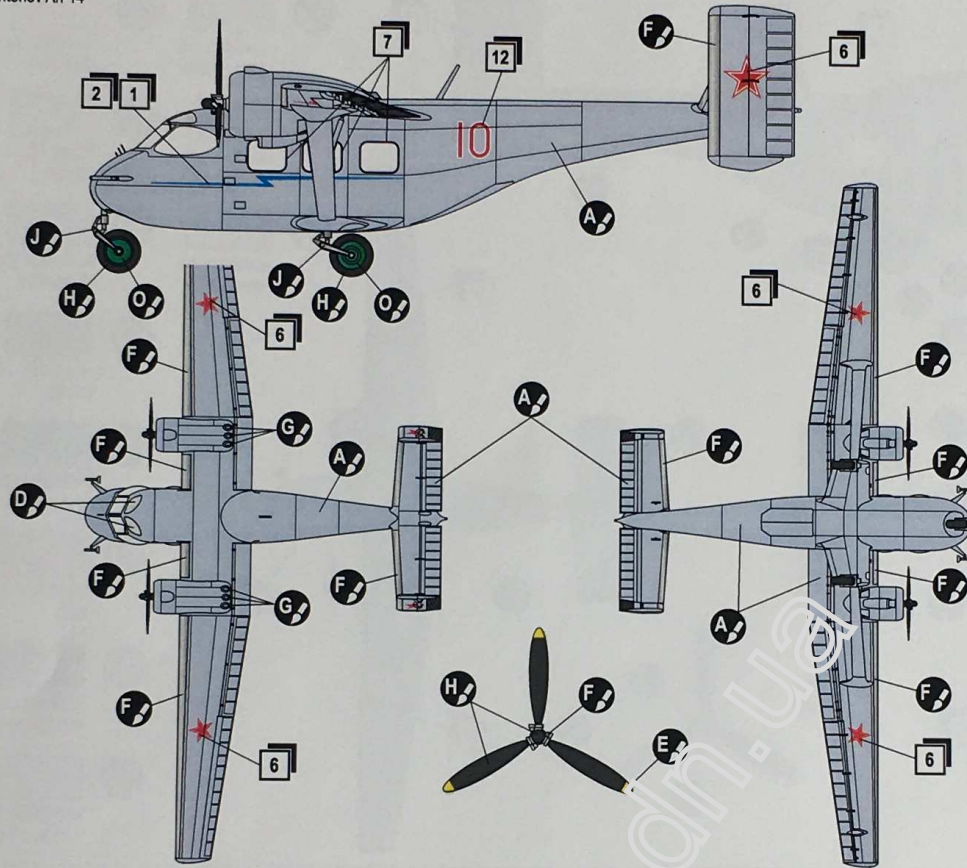

- A** HUMBROL 145 MEDIUM GREY
- D** HUMBROL 64 LIGHT GREY
- E** HUMBROL 24 YELLOW
- F** HUMBROL 11 SILVER
- G** HUMBROL 53 GUNMETAL
- H** HUMBROL 33 BLACK
- J** HUMBROL 56 ALUMINIUM
- O** HUMBROL 101 MID GREEN

Antonov An-14

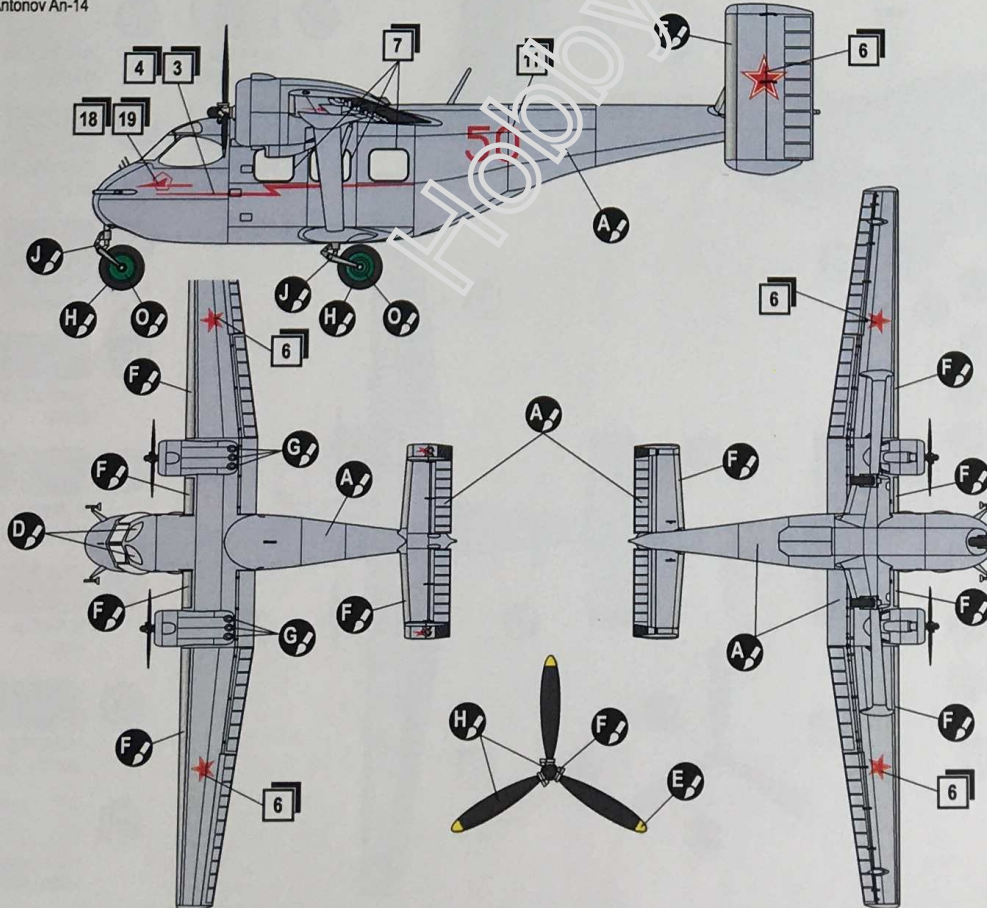

- A** HUMBROL 145 MEDIUM GREY
- D** HUMBROL 64 LIGHT GREY
- E** HUMBROL 24 YELLOW
- F** HUMBROL 11 SILVER
- G** HUMBROL 53 GUNMETAL
- H** HUMBROL 33 BLACK
- J** HUMBROL 56 ALUMINIUM
- O** HUMBROL 101 MID GREEN

Antonov An-14

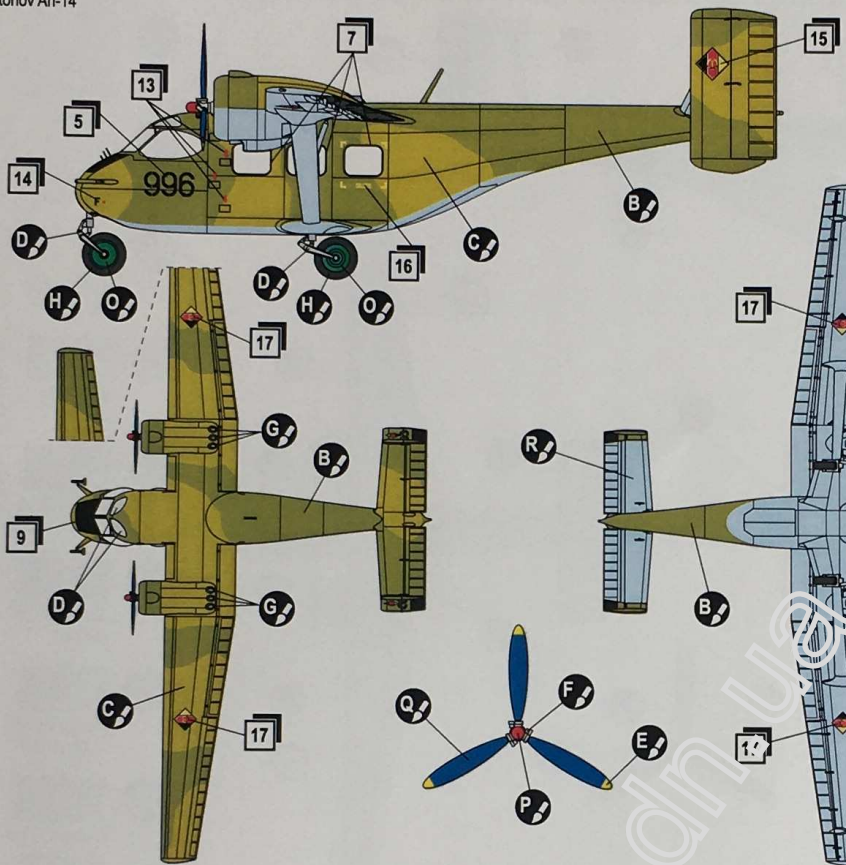

- B** HUMBROL 102 ARMY GREEN
- C** HUMBROL 26 KHAKI
- D** HUMBROL 64 LIGHT GREY
- E** HUMBROL 24 YELLOW
- F** HUMBROL 11 SILVER
- G** HUMBROL 53 GUNMETAL
- H** HUMBROL 33 BLACK
- O** HUMBROL 101 MID GREEN
- P** HUMBROL 19 RED
- Q** HUMBROL 89 MIDDLE BLUE
- R** HUMBROL 65 AIRCRAFT BLUE

Antonov An-14

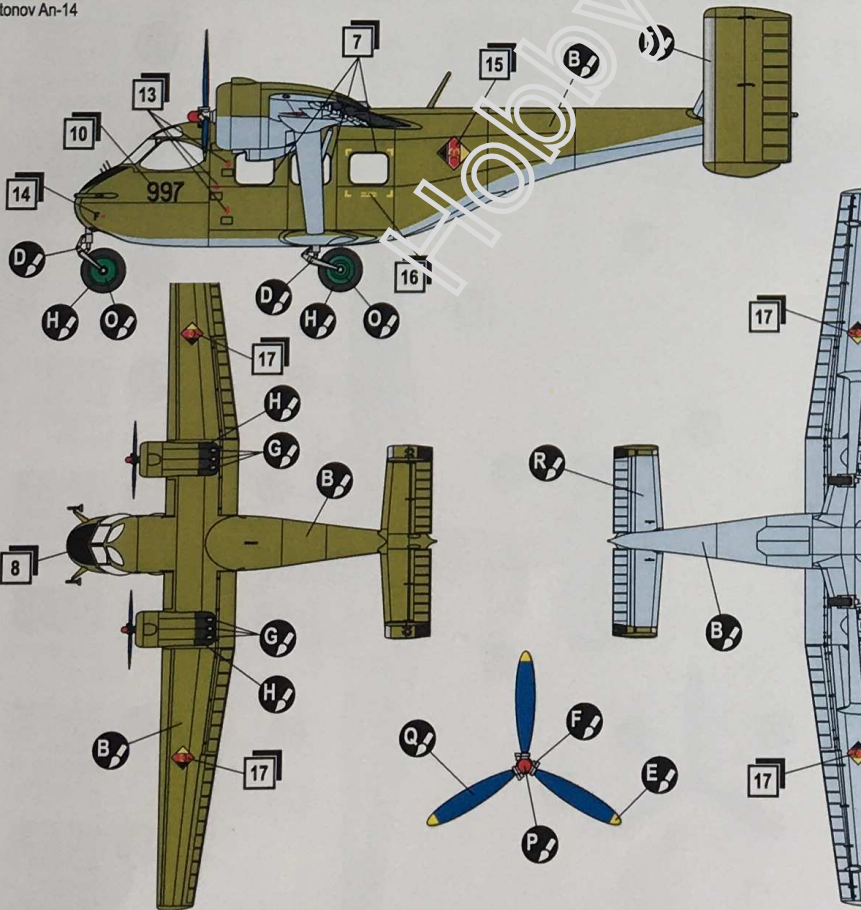

- B** HUMBROL 102 ARMY GREEN
- D** HUMBROL 64 LIGHT GREY
- E** HUMBROL 24 YELLOW
- F** HUMBROL 11 SILVER
- G** HUMBROL 53 GUNMETAL
- H** HUMBROL 33 BLACK
- O** HUMBROL 101 MID GREEN
- P** HUMBROL 19 RED
- Q** HUMBROL 89 MIDDLE BLUE
- R** HUMBROL 65 AIRCRAFT BLUE