

AUTOBLINDO

1ZM

Scala 1/7

Manuale di Istruzioni

hobby.dn.ua



ITALIAN ARMoured CAR LANCIA 1ZM

During the Great War, there were several Italian armoured car designs, but many of these projects and vehicles had to be abandoned because of a lack of sufficient experience. The most serious effort towards building an effective vehicle was from Ansaldo, well experienced in the manufacture of armour plates and a chief supplier of steel to the Italian armed forces. Ansaldo design and technical advice led in 1915 to a vehicle of welded construction mounted on a Lancia 1Z truck chassis. This chassis remained the same on all Lancias produced between 1915 and 1918, with only minor variations.

Although superficially very much the same in appearance as the Model 1915 (1Z), the Model 1917's (1ZM) most noticeable differences were more rounded mudguards, a bracket for a new signal light and more interior equipment. The armoured plates of the Model 1917 1ZM were in some cases of inferior quality, as plates were made of molybdenum steel instead of the original nickel-chromium steel because of wartime shortages of chromium and nickel.

There are some key features that distinguish the late-pattern vehicles from the early vehicles. The early Lancia version (1Z) had two Fiat-Revelli 6.5 mm machine guns in its low cylindrical turret and a third one in a smaller turret on top of it (which could rotate independently), but the weight made the centre of gravity too high, leading to accidents. A new turret design eliminated the top machine gun and placed it in the rear of the hull, with a limited traverse but with better depression. It does not seem that the third machine gun was usually operated from the shelter of the hull's rear, but a light machine gun could fire from a small circular hatch on the turret's top. Despite that, the Lancia was used extensively during peacetime and between the wars. Cars were frequently upgraded or modified, from a 1923 armament changeover (Fiat 14 instead of the wartime air-cooled French St. Etienne) until the last modifications of 1935-1936, when new wheels were used instead of the original disc pattern. The last surviving example, which was rearmed with a new type of Breda-Safat 7.7 mm machine gun, escaped being scrapped after the war and is on display in the Trieste Museum.

CAMOUFLAGE AND MARKINGS

The first Lancias left the Ansaldo plant finished in a standard overall medium grey paint, but soon all Italian vehicles were given a base coat of a single colour, a light 'grigioverde' (grey-green). From late fall of 1917, vehicles started to be painted in a new grey-green. The latter colour is darker than the previous shade, a medium green with a little grey tone with a semi-gloss finish. The interior of the vehicles were painted ivory white, while nearly all had the bottom half of the interior surface of their access doors camouflaged in grey-green or black.

Important Notes

- Read the instructions carefully before starting the assembly.
- Use glue intended for plastic models.
- Choking hazard. Keep small parts and plastic bags away from children.
- Always wear protective eyewear when cutting and a protective mask when painting, glueing and sanding.
- Use paints designed and suitable for plastic model kits.

Symbols Reference

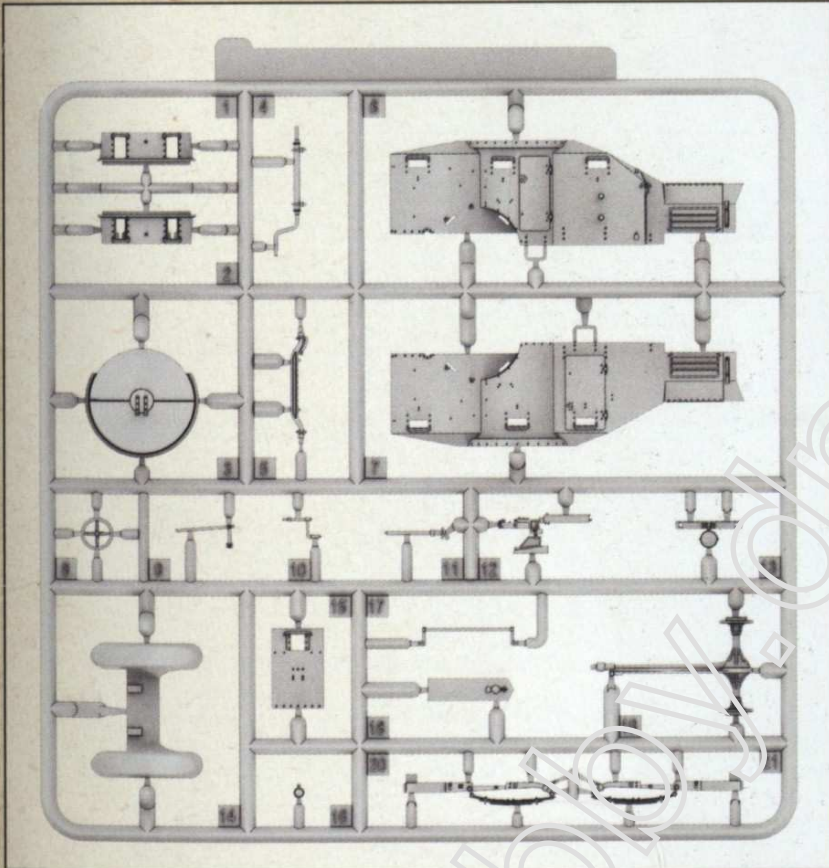
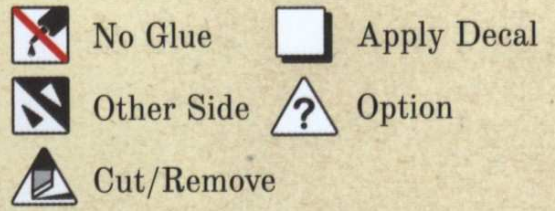

Fig. 1. Runner A

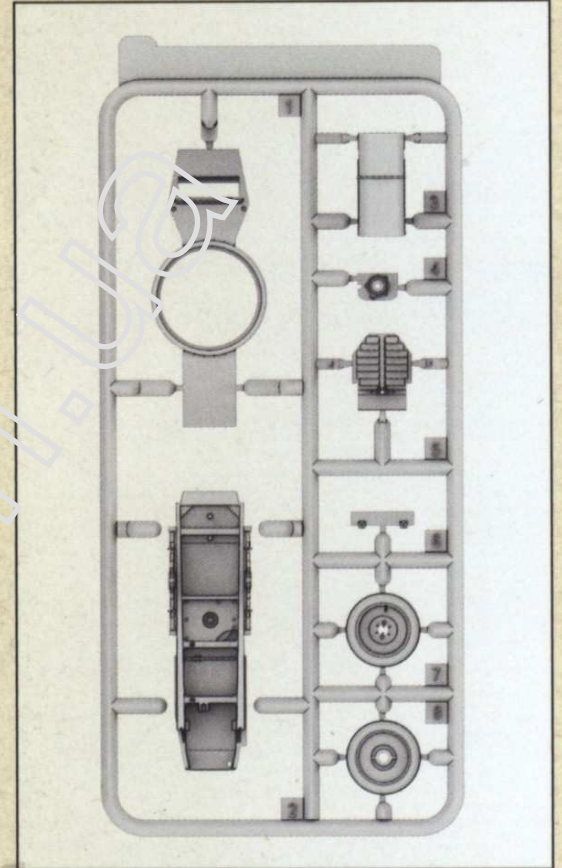

Fig. 2. Runner B

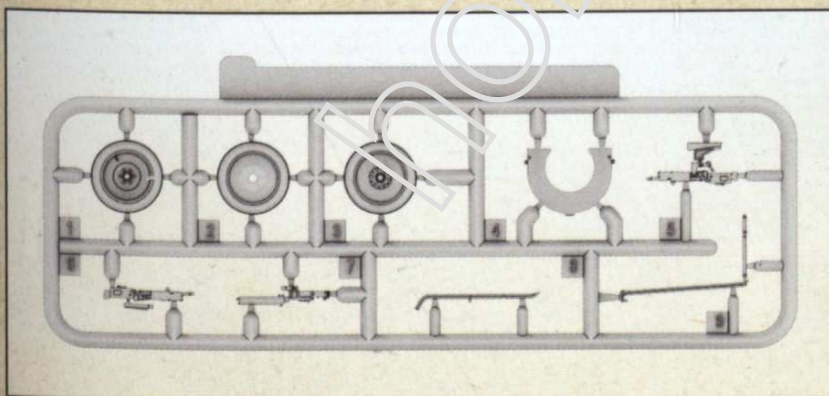

Fig. 3. Runner C, x2 pieces



Fig. 4. Decals

Colour numbers

	Burnt metal (exhaust)		Steel		Gun metal		Rubber (light)
	Rubber (dark)		Black		Wood		Dark green
	White		Brass		Light Green		Green (FS 14115)

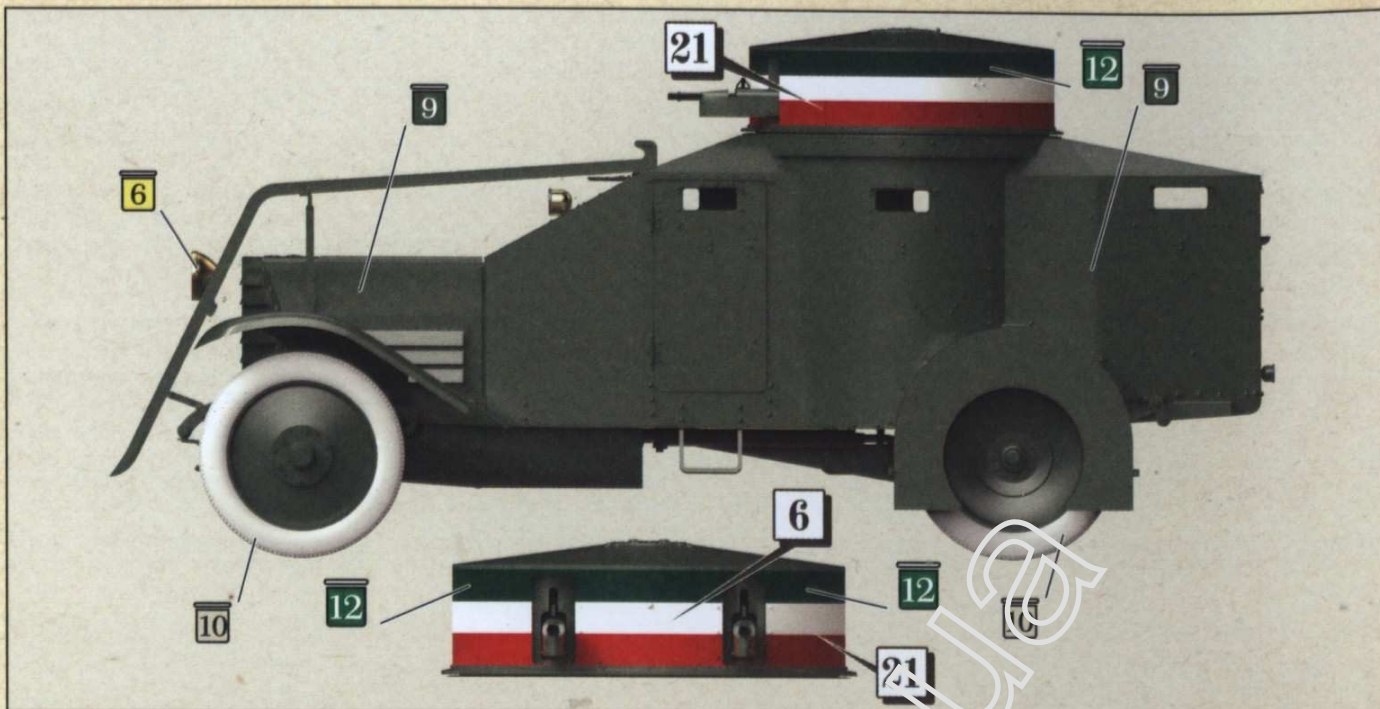

Fig. 5. National colours on the turret, for all Lancias in the army's squadrons, from late 1917 to November 1918. Some squadrons had only Fiat Revelli MG-equipped vehicles, while others had only St. Etienne, and some had a mix of both vehicles. Squadrons 3, 4, 5, 7, 8, 9, 10, 11, 14, 15 and 16 were equipped with the St. Etienne MG on their Lancias

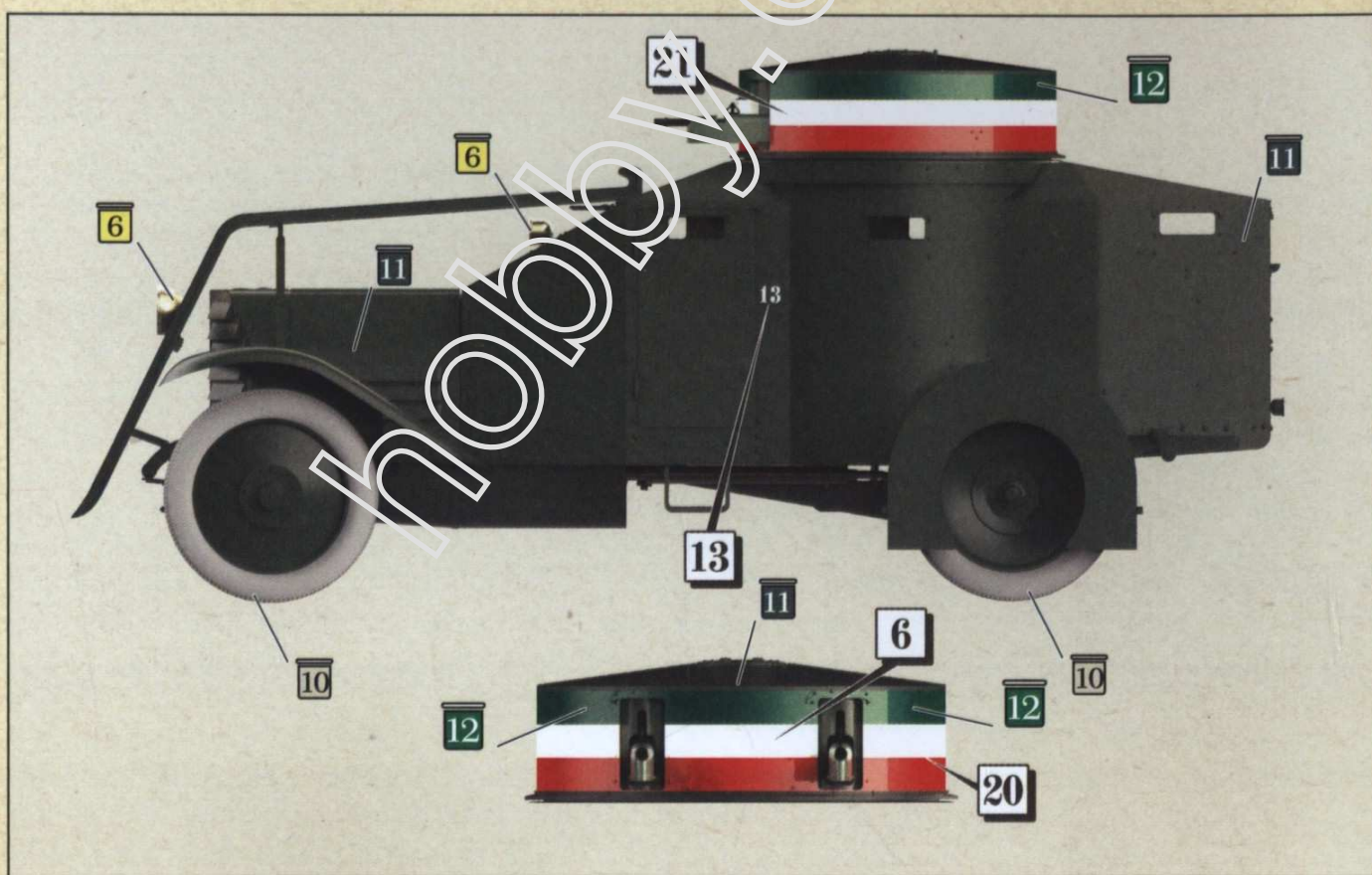

Fig. 6. Unknown unit – Northeast Italy – summer 1918. Grey-green (dark), with a small white 13 on the sides and the national colours on the turret (red – white – green)

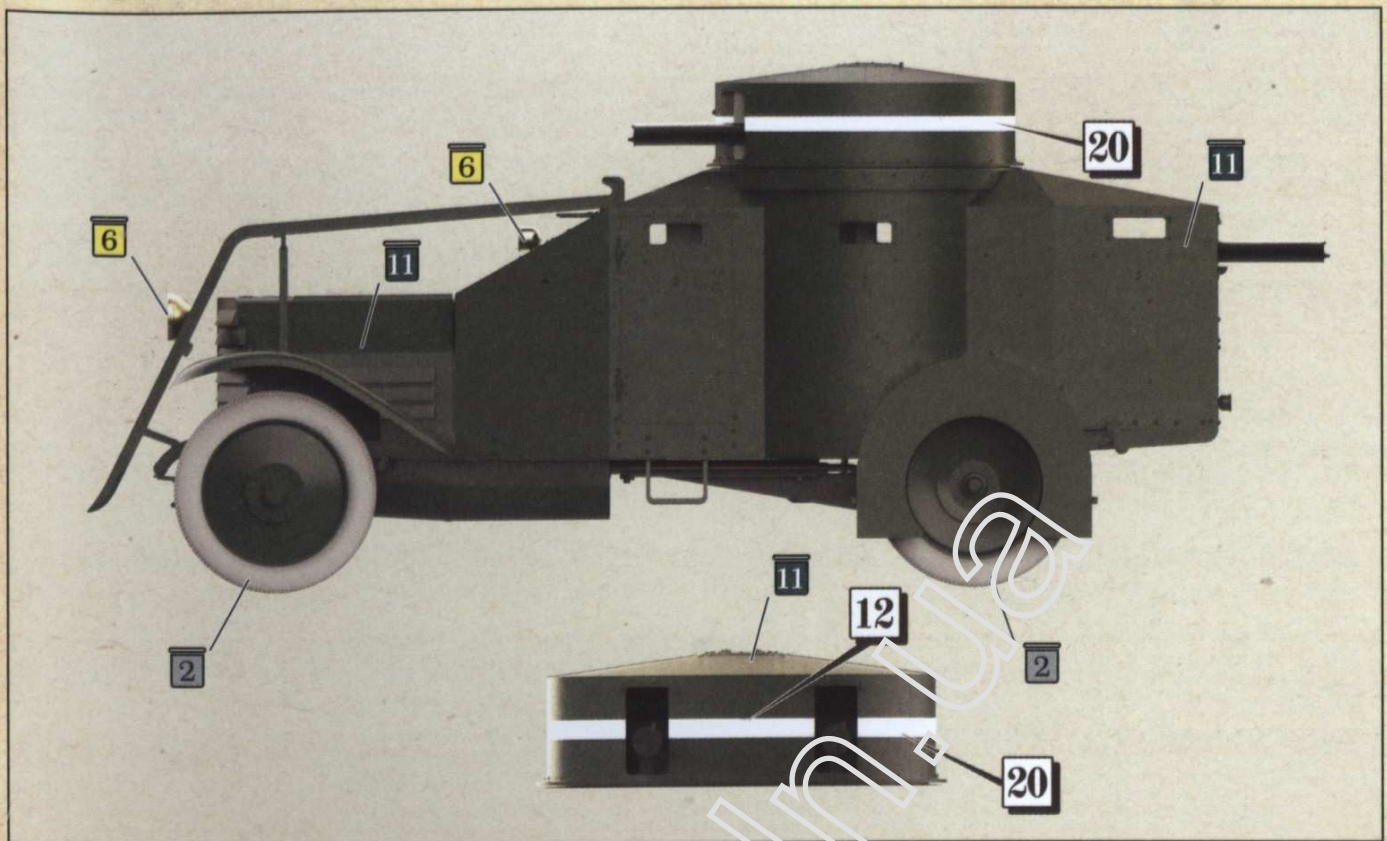

Fig. 7. 2nd Squadron, 3rd "Cacciatori d'Africa" (Africa's Light Infantry), Berka barracks, Benghazi, Libya January 1923

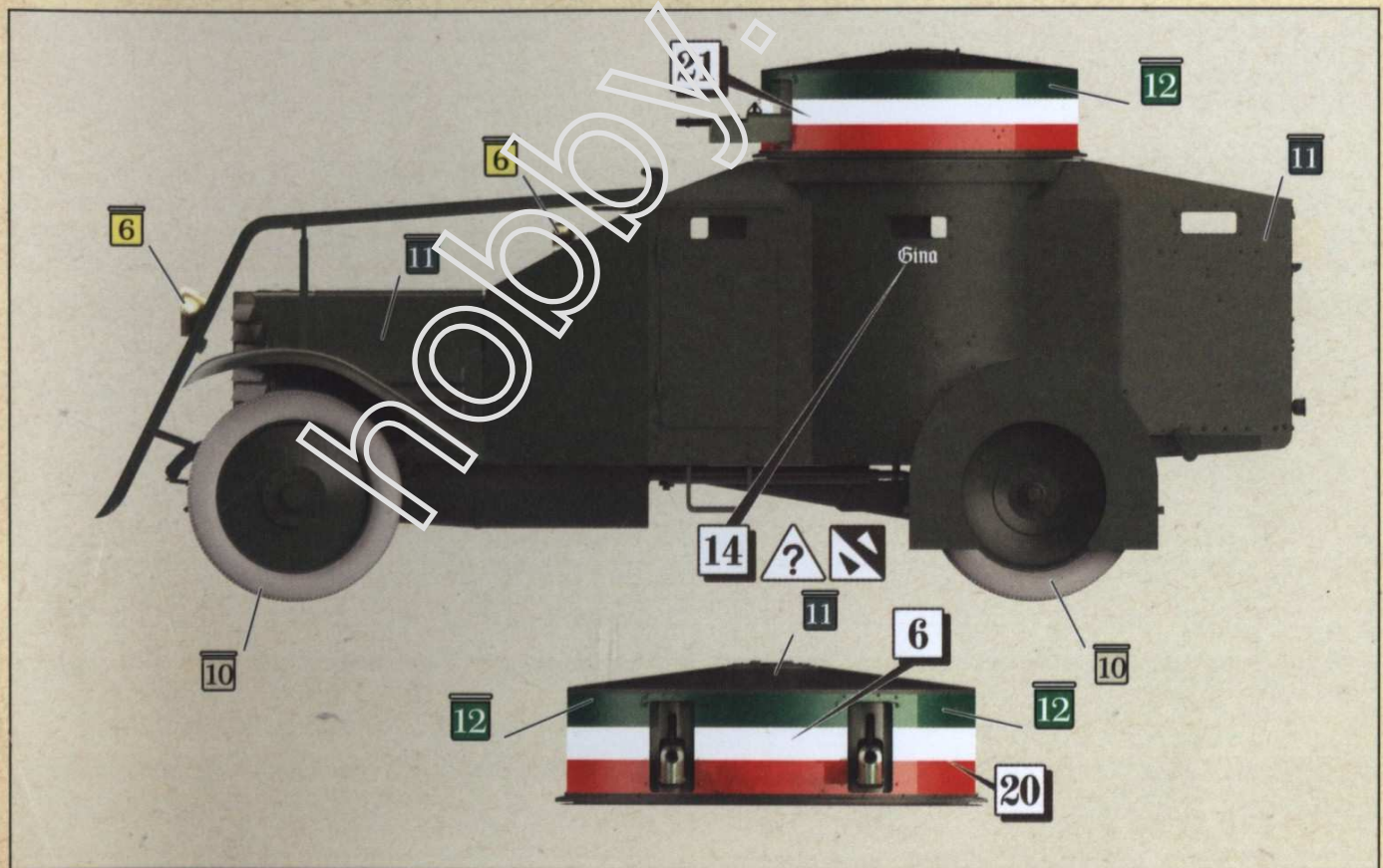

Fig. 8. 11th Squadron - Innsbruck (Austria) - February 1919. Grey-green, with a small woman name 'Gina' on the sides and national colours on the turret

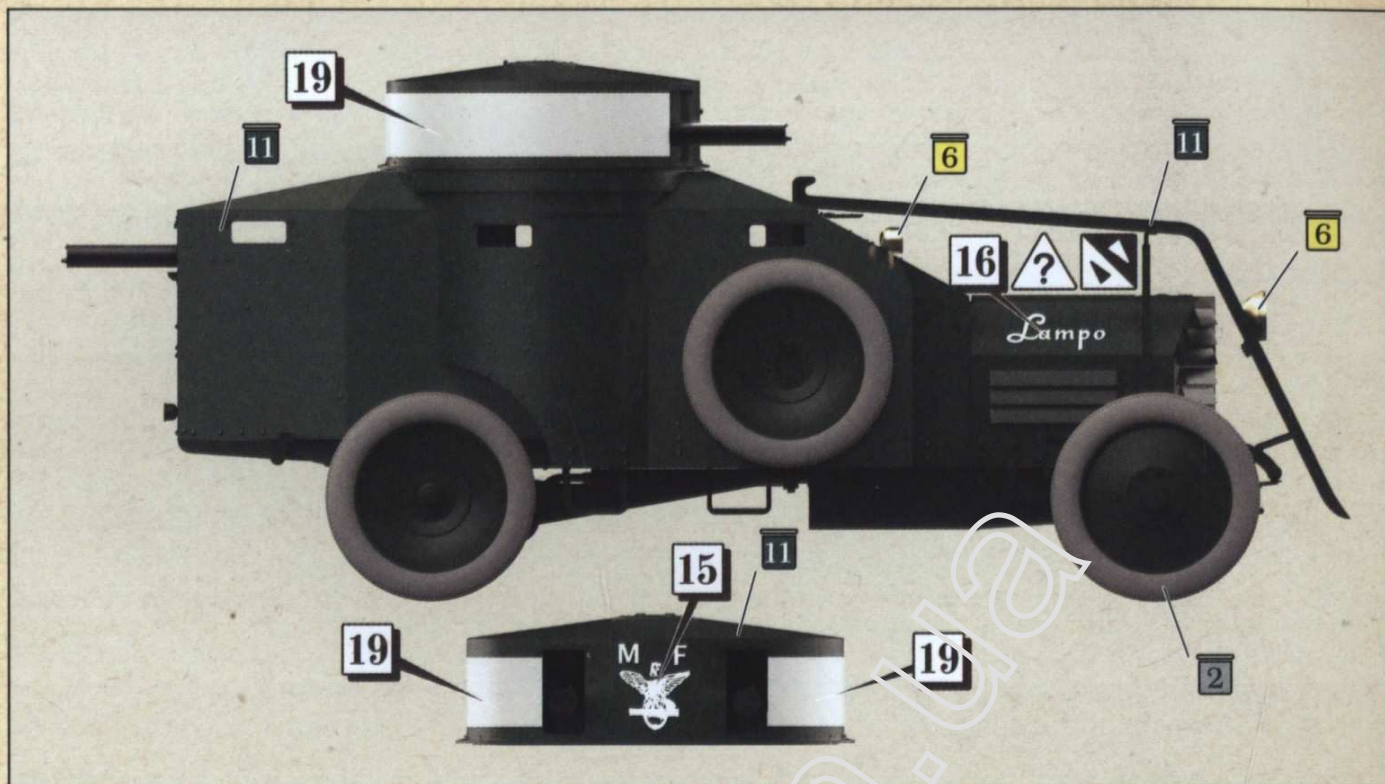

Fig. 9. 1st Libyan Legion (Black Shirts), Parce (Libya), October 1929. Faded grey-green, with uncommon national colours in the turret (white stripe larger than usual) and a white, italic, vehicle name 'Lampo' (Lightning) on the engine bonnet

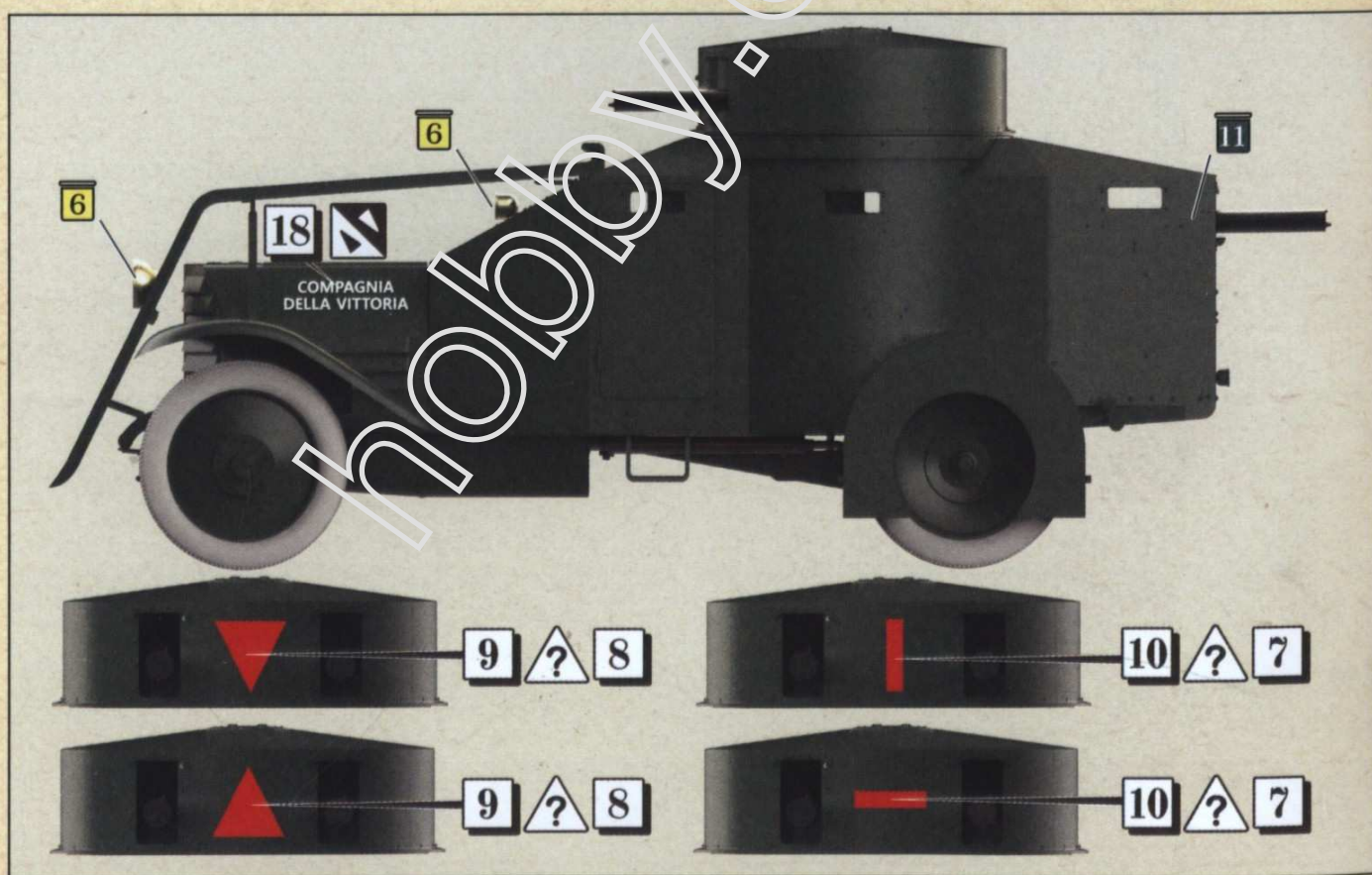

Fig. 10. Lancia's Section, Mechanized Company of Zara, Zara (Northeast Italy) around 1935. Grey-green, with red (black?) marking on the turret's front and the white words COMPAGNIA DELLA VITTORIA (Victory's Company)

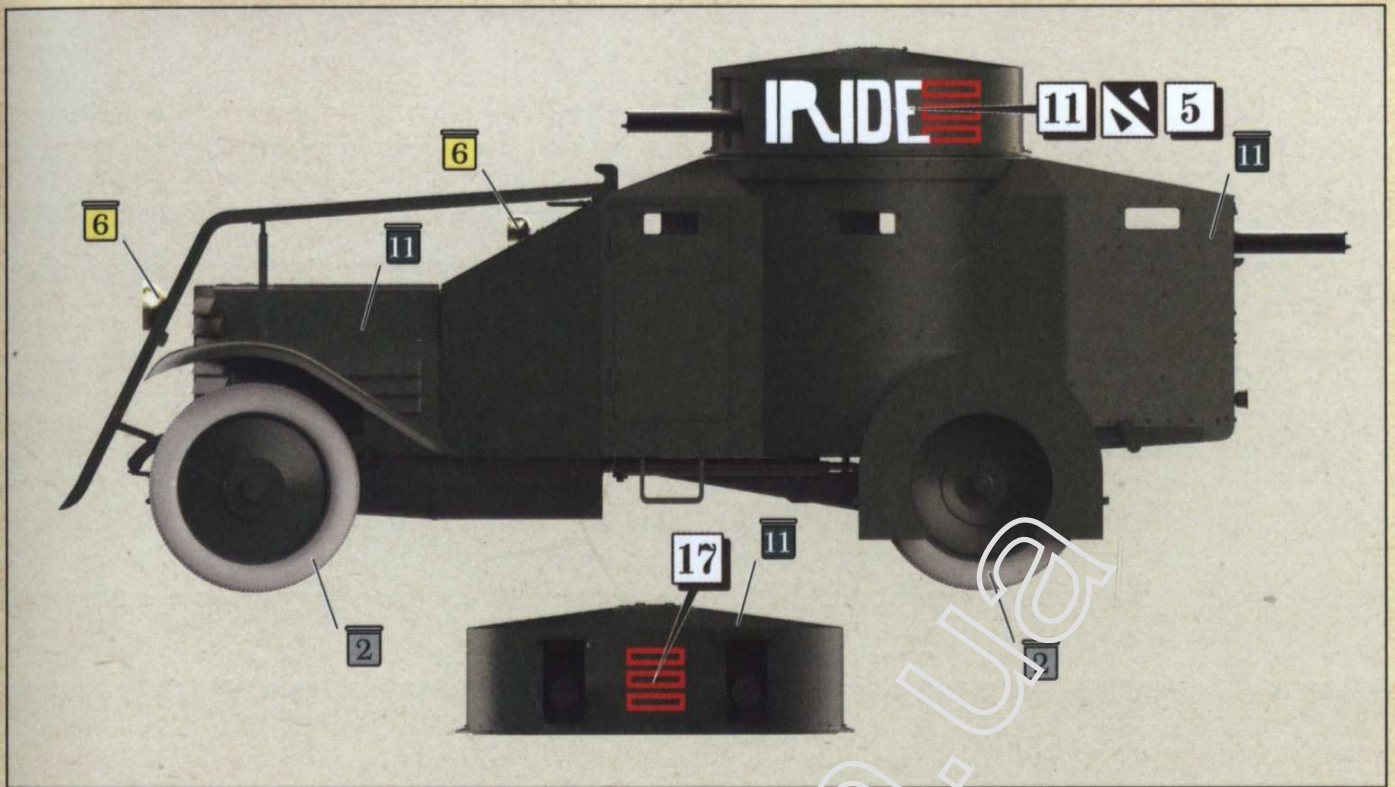

Fig. 11. Unknown unit - Ethiopia 1936. Faded dark brown, with red markings (hollow type) on sides of the turret and large white name IRIDE

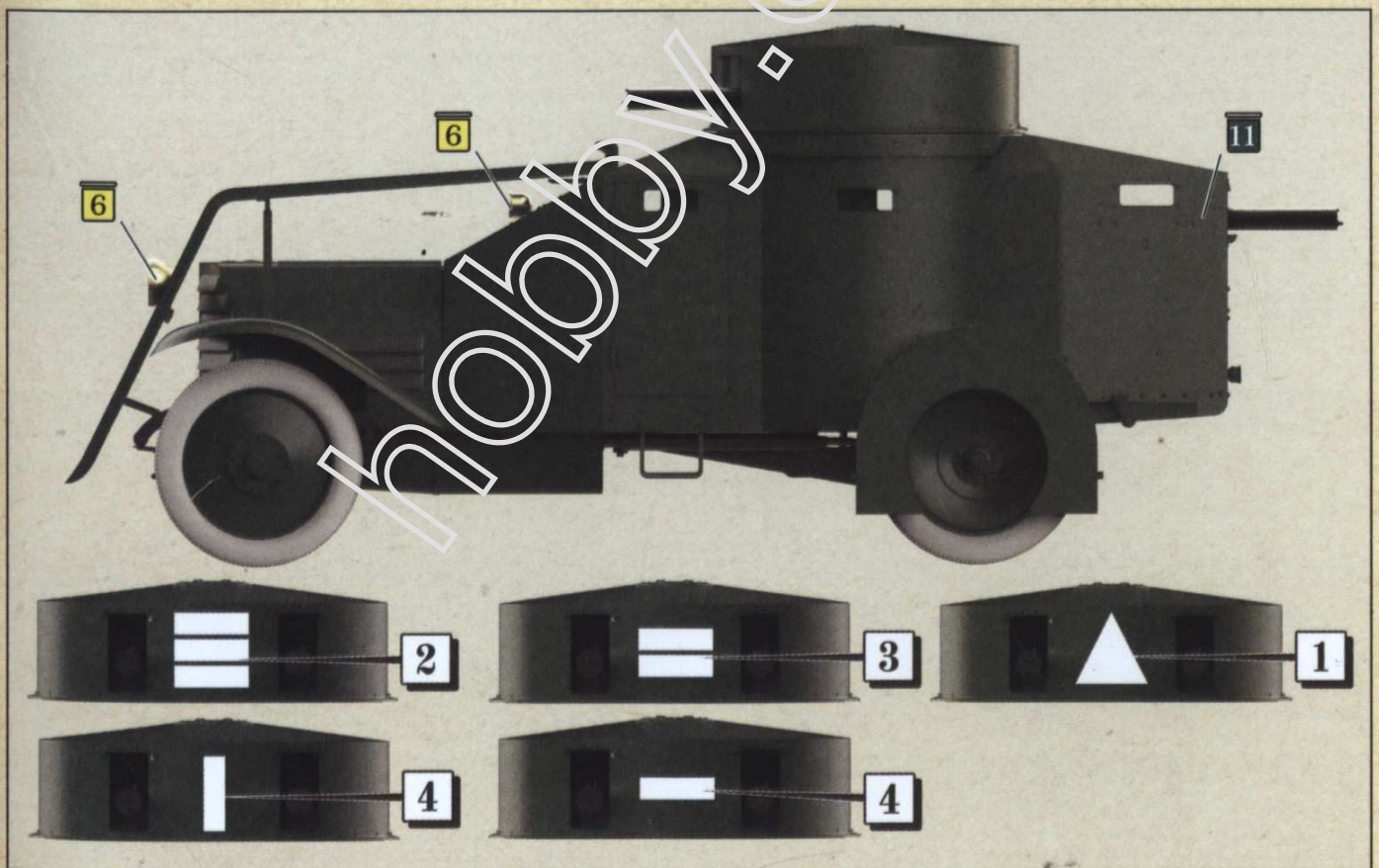
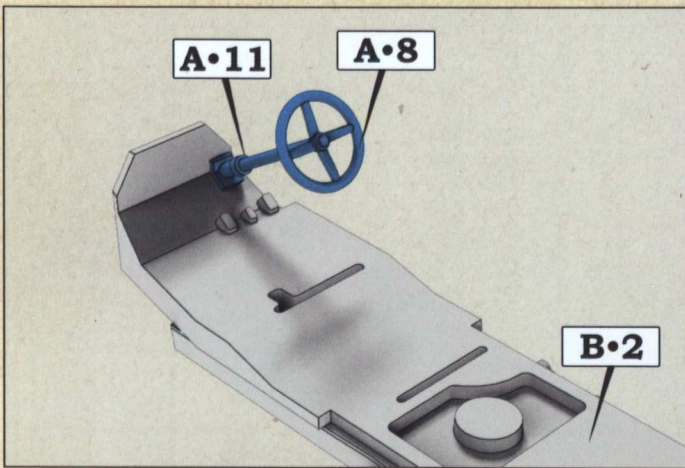

Fig. 15. Armoured car group, Tank Regiment, Bologna (Italy) 1929. Grey-green, with the unit white code number 4.6 on the sides and the white triangle of a platoon commander on the turret front



Step 1. Installation of the steering wheel



Step 2. Additional actions ONLY FOR no fenders markings

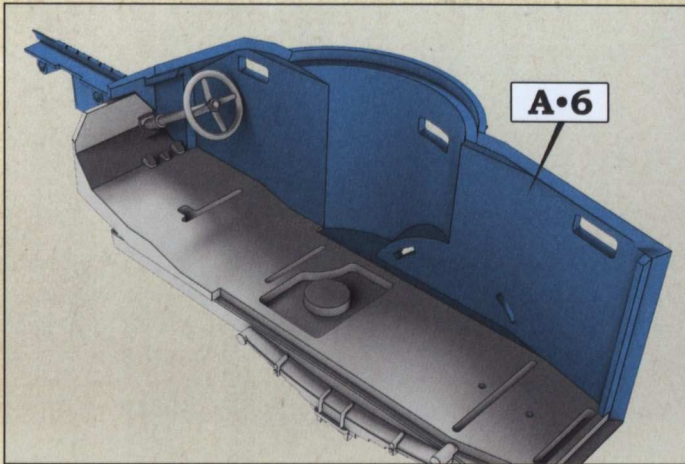

Step 3. Installation of the starboard superstructure wall

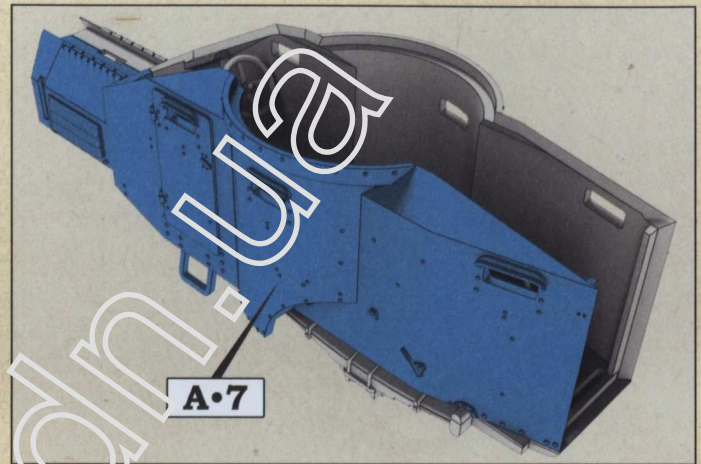

Step 4. Installation of the port superstructure wall

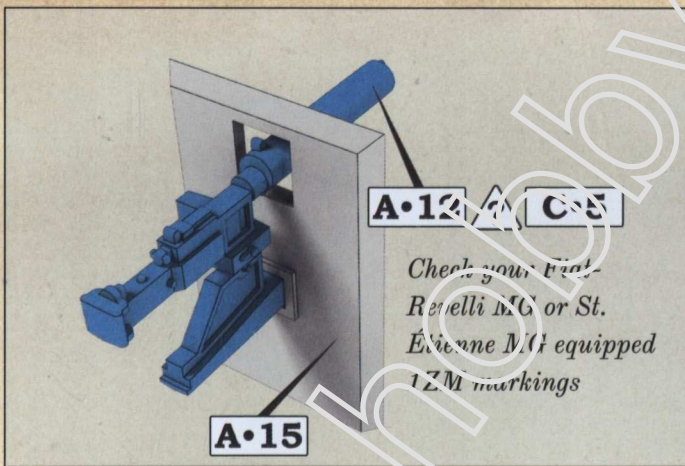

Step 5. Installation of the rear MG

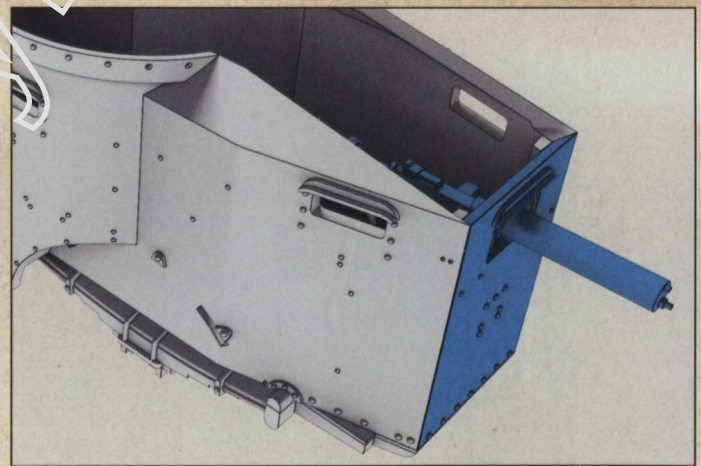

Step 6. Installation of the superstructure rear wall

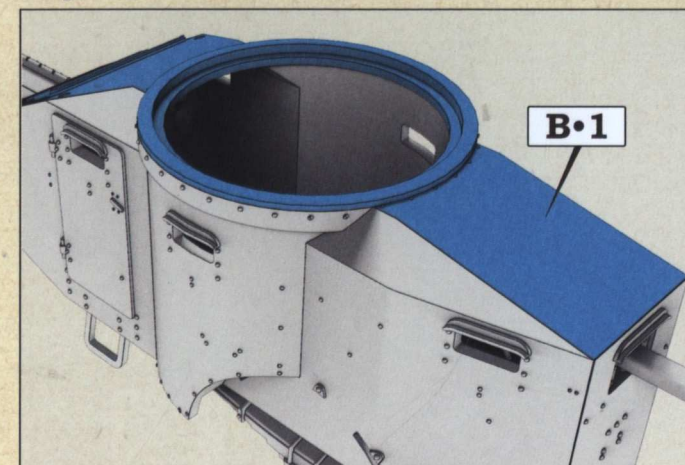

Step 7. Installation of the armoured roof

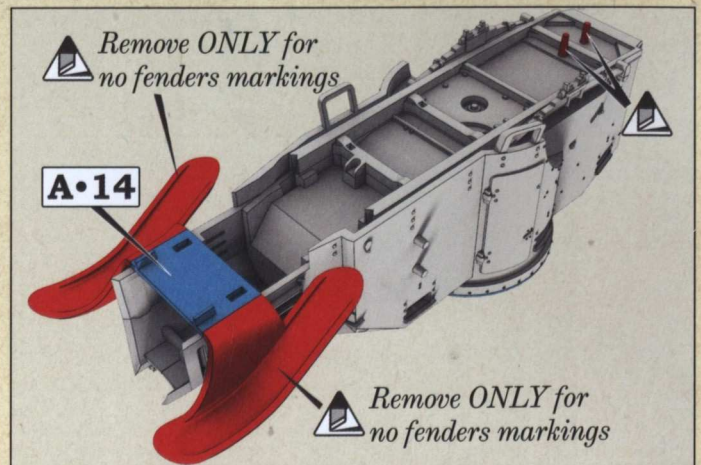

Step 8. Front fenders additional correction

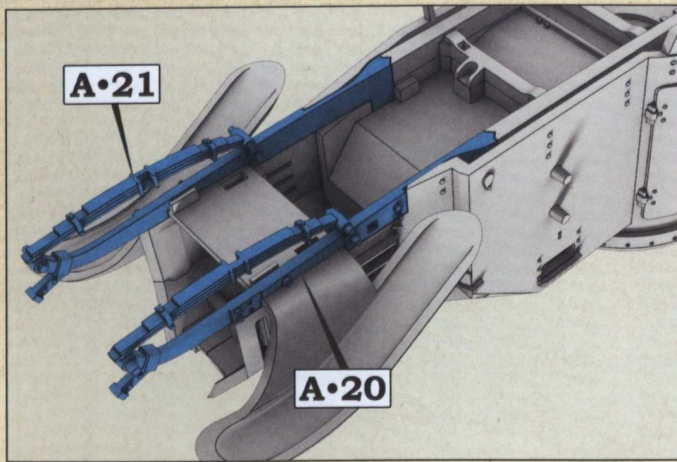

Step 9. Installing both side rails

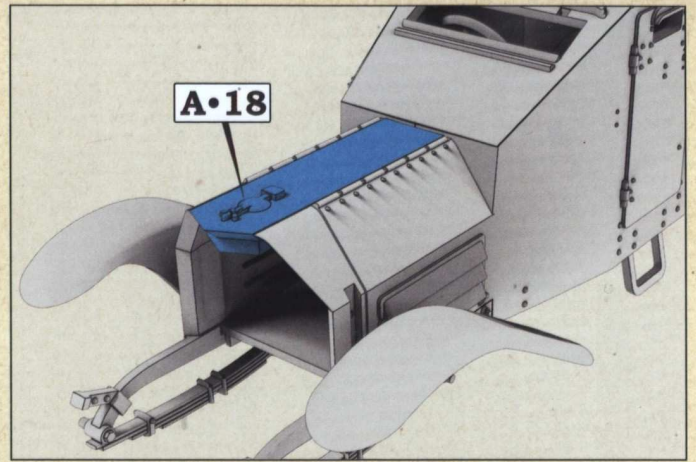

Step 10. Installation of the engine armoured hood

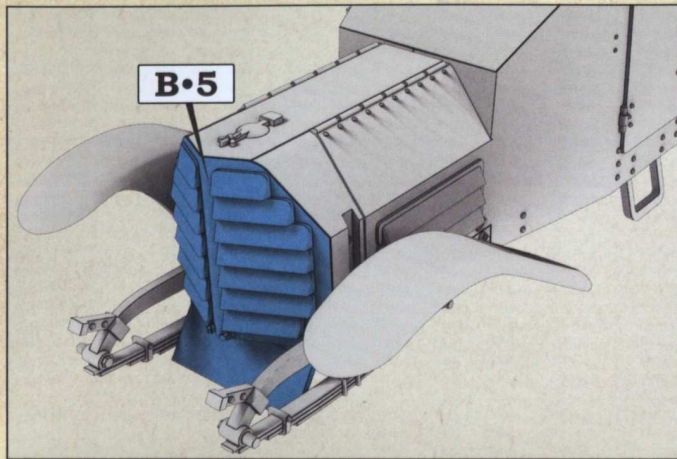

Step 11. Installation of the radiator armour

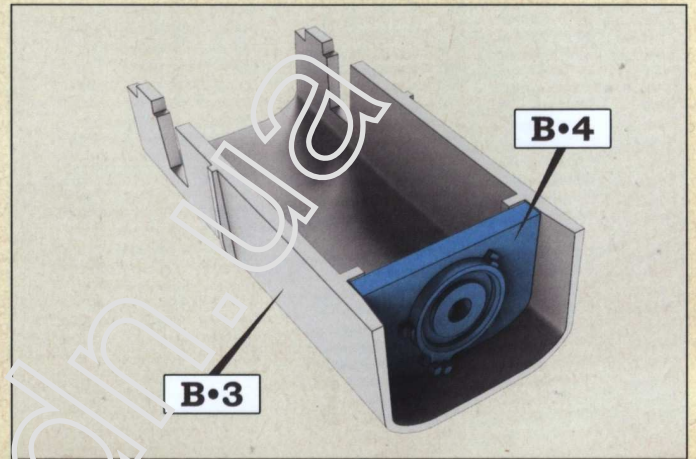

Step 12. Assembling the engine protection

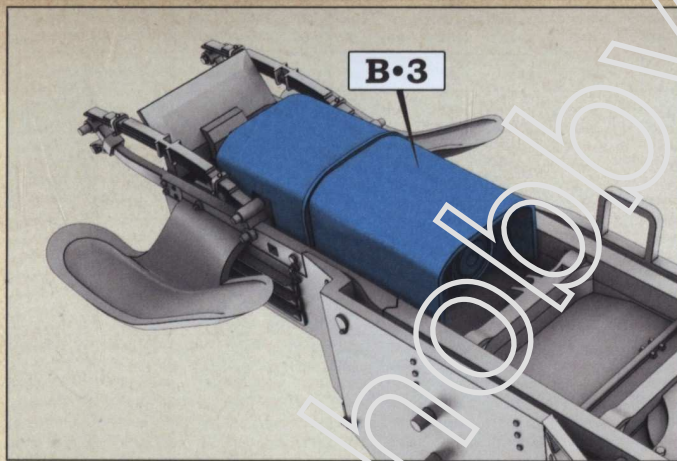

Step 13. Installation of the engine protection

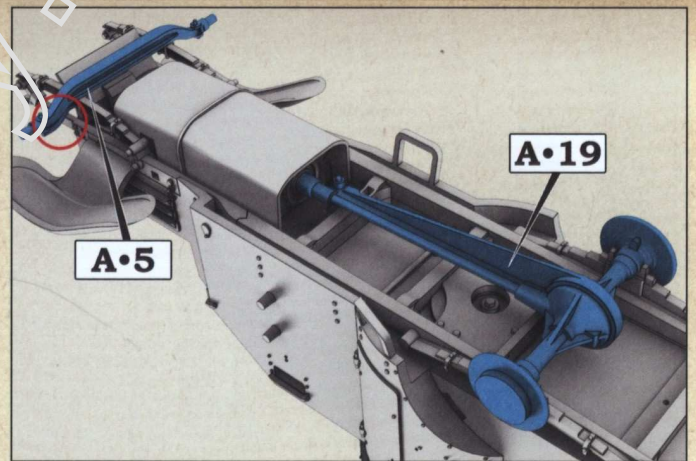

Step 14. Installing the front and rear axles

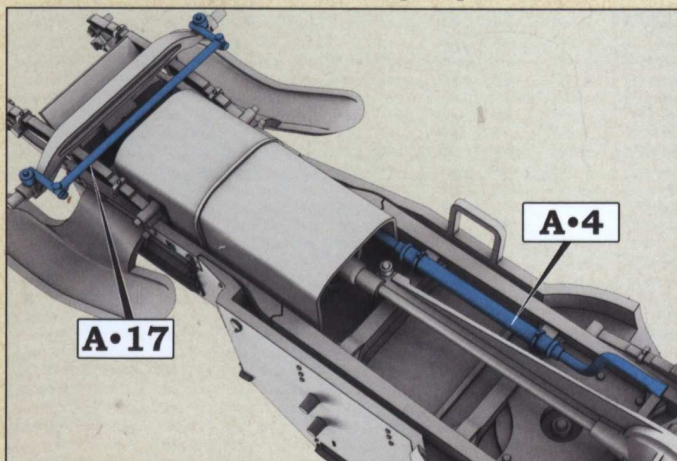

Step 15. Installation of the exhaust pipe and tie rod

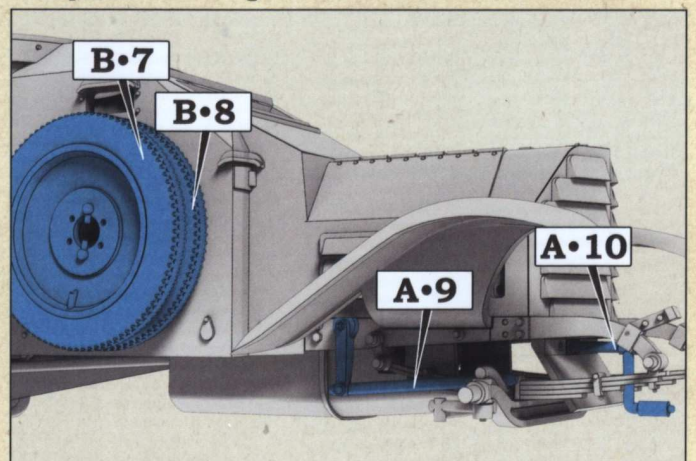

Step 16. Installation of the spare, steering arm and the hand crank

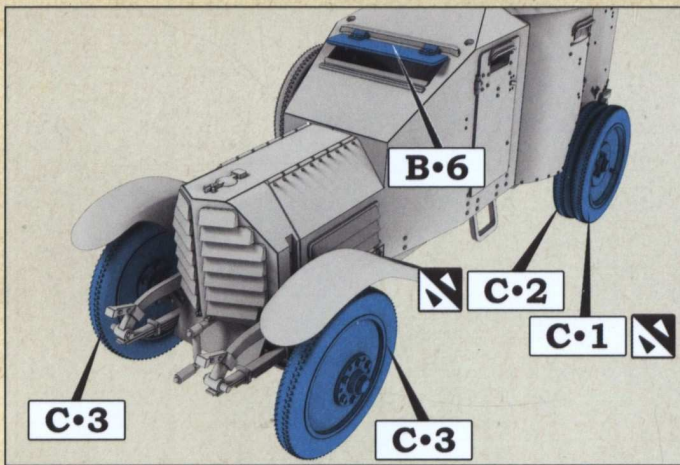

Step 17. Installation of the wheels and driver's hatch

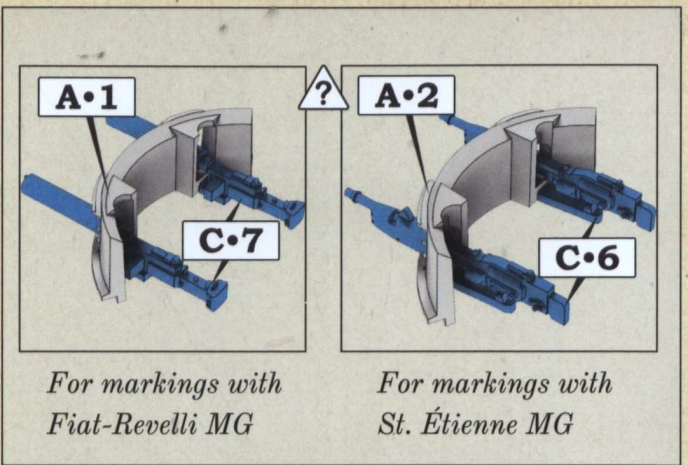

Step 18. Installation of the turret's MG

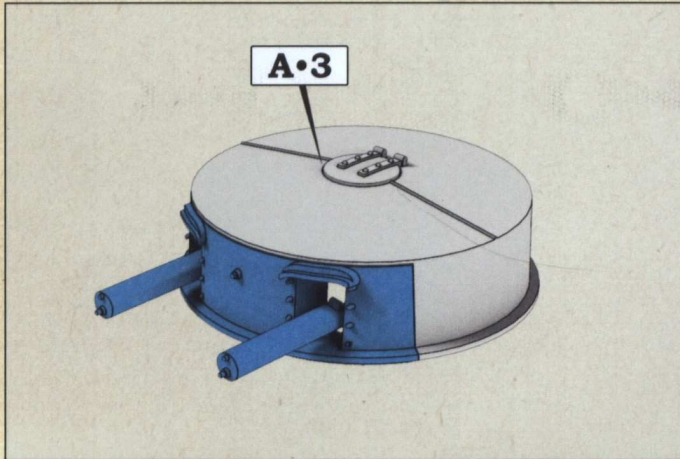

Step 19. Assembling the turret

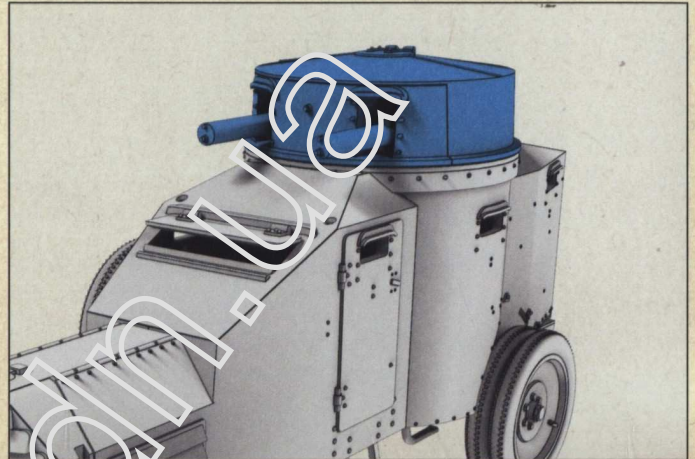

Step 20. Installation of the turret

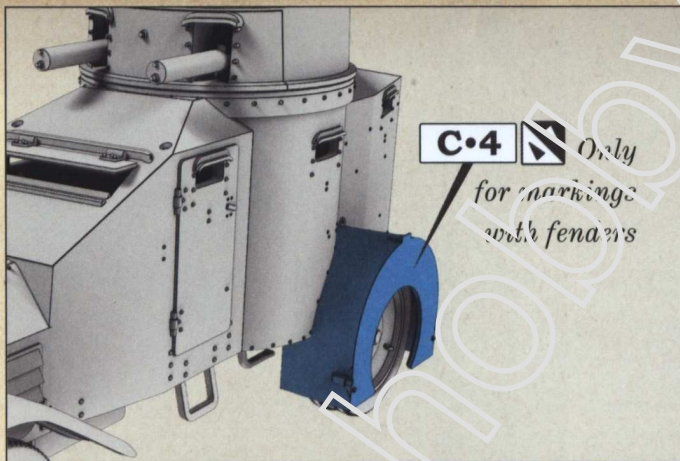

Step 21. Installation of the rear fenders.

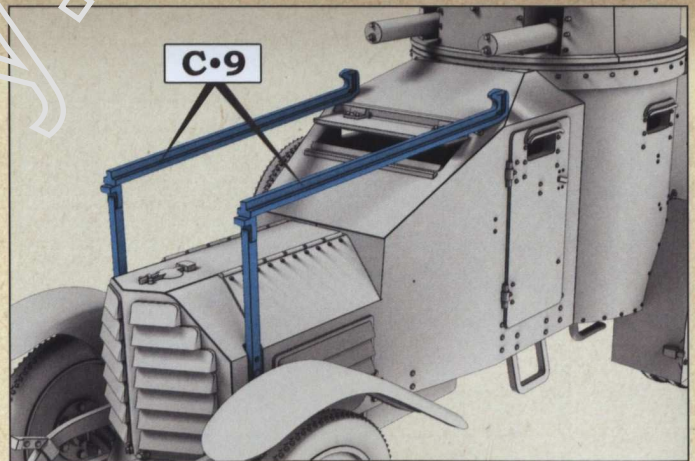

Step 22. Installing the wire cutters

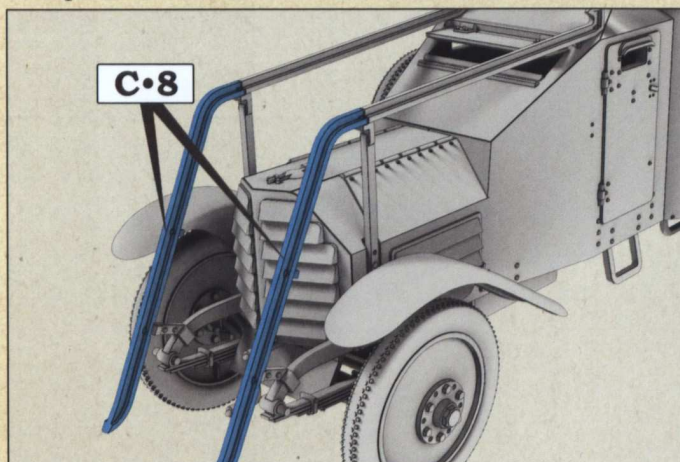

Step 23. Installing the wire cutters

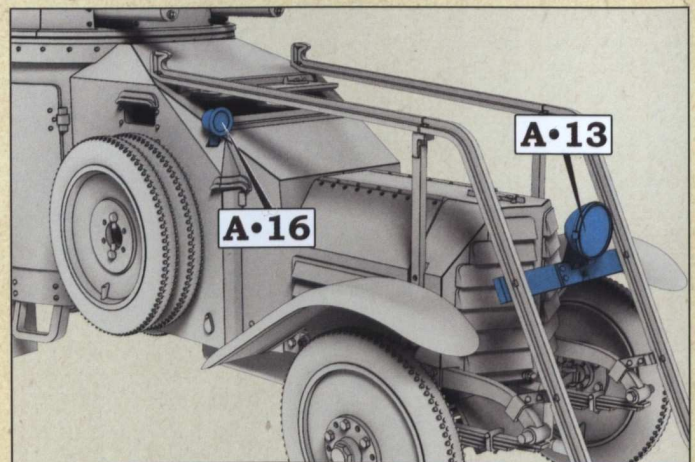

Step 24. Installation of the side lamp and headlamp



Fig. 13. Machine guns

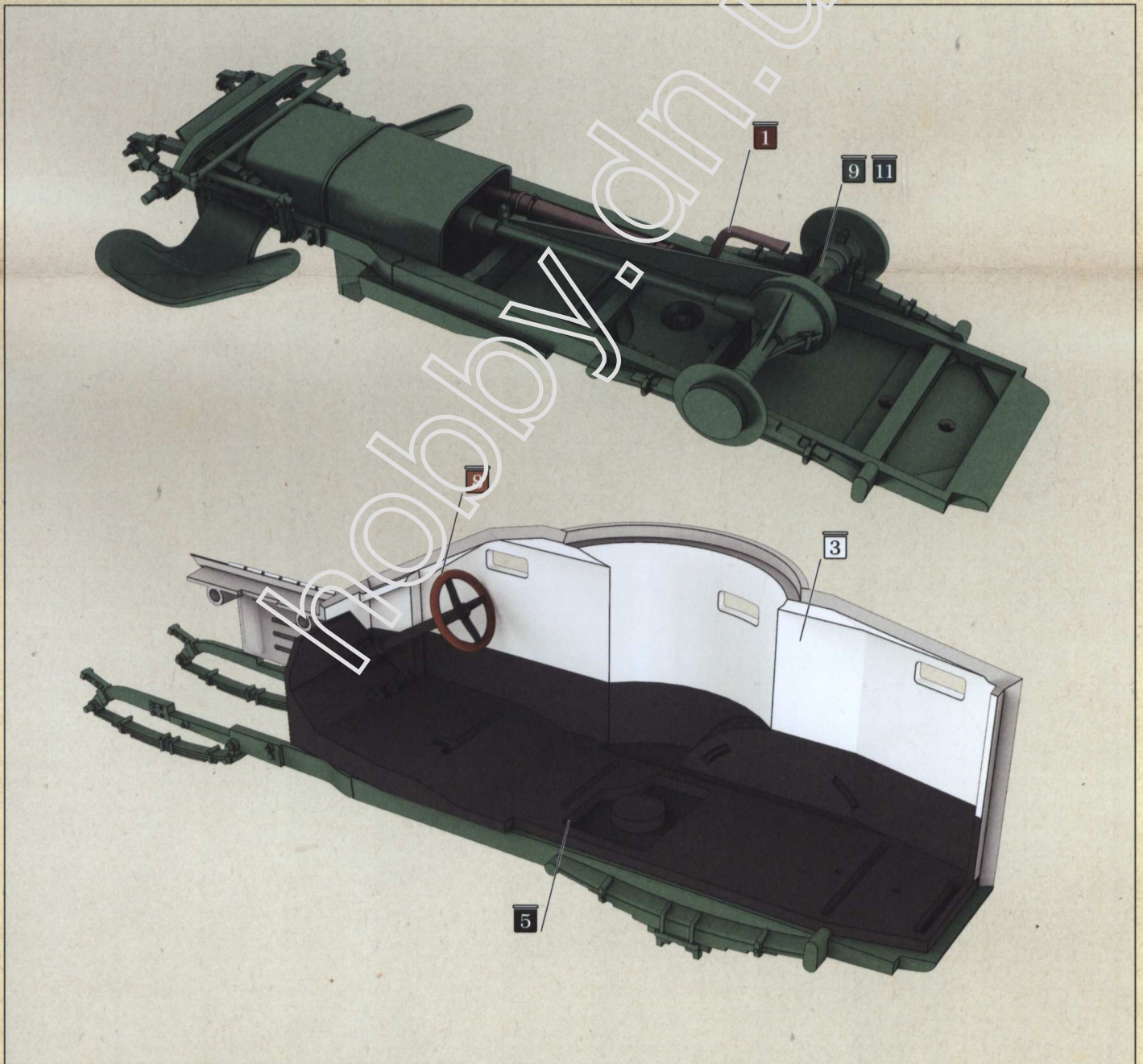

Fig. 14. Colours for the chassis and interior (only steering wheel will be partly visible)