

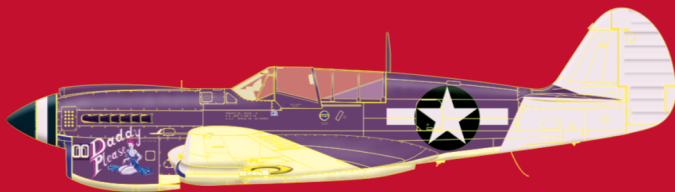

SECRET  
N

INSTRUCTION S

# WARHAWK P-40

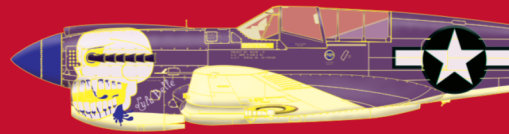
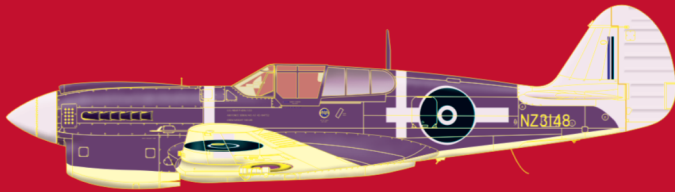
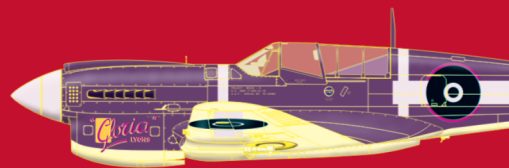
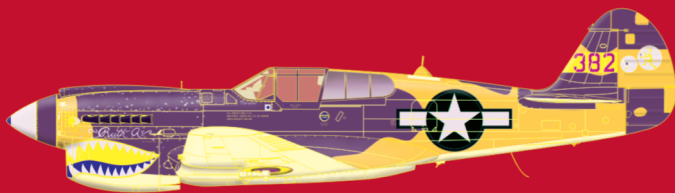
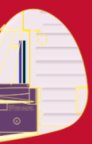

ard

e



Carefully read instruction sheet before assembling. When you use glue or paint, do not use near open flame and use in well ventilated room. Keep out of reach of small children. Children must not be allowed to suck any part, or pull vinyl bag over the head.



Před započítím stavby si pečlivě prostudujte stavební návod. Při používání barev a lepidel pracujte v dobře větrané místnosti. Lepidla ani barvy nepoužívejte v blízkosti otevřeného ohně. Model není určen malým dětem, mohlo by dojít k požití drobných dílů.

## INSTRUCTION SIGNS \* INSTR. SYMBOLS \* INSTRUKTION SINNBILDEN \* SYMBOLES \* 記号の説明



OPTIONAL  
VOLBA



BEND  
OHNOU



OPEN HOLE  
VYVRTAT OTVOR



SYMMETRICAL ASSEMBLY  
SYMETRICKÁ MONTÁŽ



REMOVE  
ODŘÍZNOUT



REVERSE SIDE  
OTOČIT



APPLY EDUARD MASK  
AND PAINT  
POUŽÍT EDUARD MASK  
NABARVIT

## PARTS



## DÍLY



## TEILE



## PIĘCES



## 部品

A&gt;

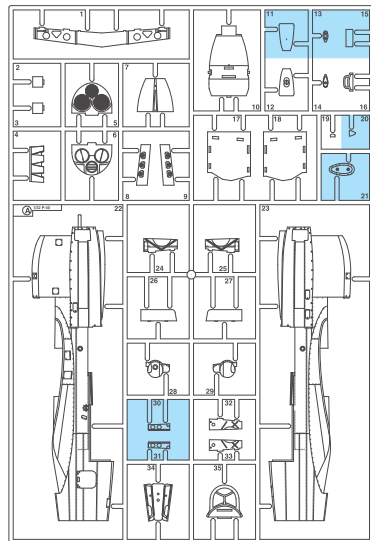

B&gt;

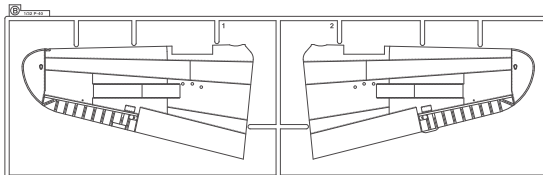

C&gt;

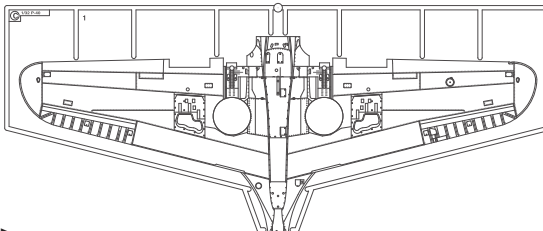

E&gt;

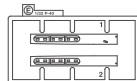

P&gt;



I&gt;

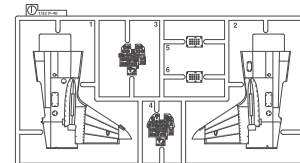

K&gt;

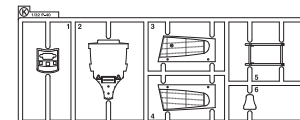

L&gt;

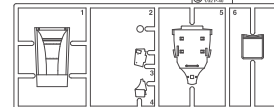

J&gt;

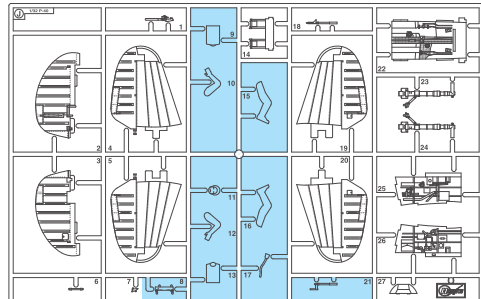

O&gt;

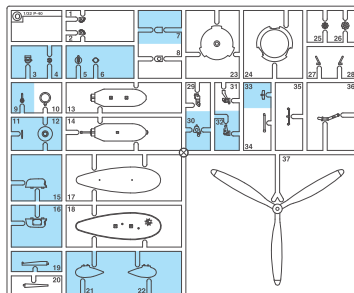

Q&gt; 2 pcs.

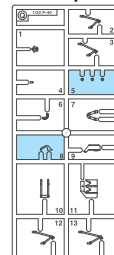

R&gt; 2 pcs.

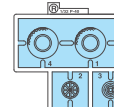

V&gt;

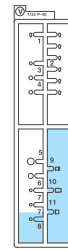

S&gt; 2 pcs.

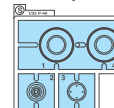

U&gt; 2 pcs.

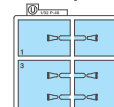

X&gt;

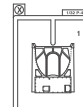

Y&gt;

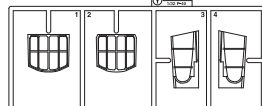

Z&gt;

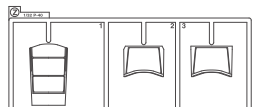

RP - RESIN PARTS

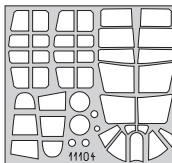
R18  
2 pcs.R21  
2 pcs.eduard  
MASK

FILM



PE - PHOTO ETCHED DETAIL PARTS

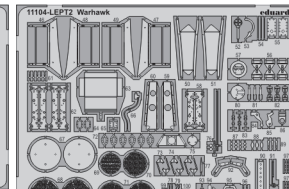
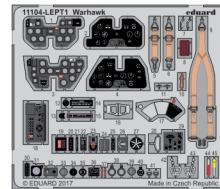

-Parts not for use. -Teile werden nicht verwendet. -Pièces à ne pas utiliser. -Tyto díly nepoužívejte při stavbě. - 使用しない部品

## COLOURS



## BARVY



## FARBEN



## PEINTURE



## 色

GSI Creos (GUNZE)		
AQUEOUS	Mr.COLOR	
H4	C4	YELLOW
H8	C8	SILVER
H11	C62	WHITE
H12	C33	FLAT BLACK
H25	C34	BLUE
H47	C41	RED BROWN
H52	C12	OLIVE DRAB
H53	C13	GRAY
H58	C351	ZINC CHROMATE
H84	C17	DARK GREEN

AQUEOUS	Mr.COLOR	
H77	C137	TIRE BLACK
H78	C38	OLIVE DRAB
H90	C47	CLEAR RED
H94	C138	CLEAR GREEN
H325	C325	GRAY
H327	C327	RED
H329	C329	YELLOW
H330	C330	DARK GREEN
Mr.METAL COLOR		
MC214		DARK IRON
MC218		ALUMINIUM

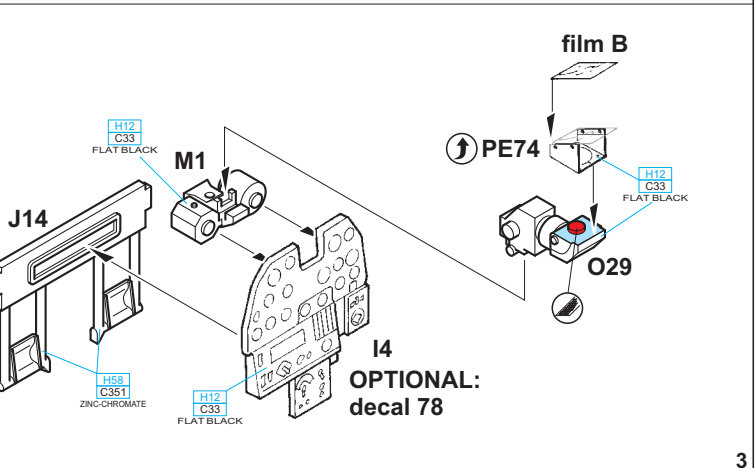
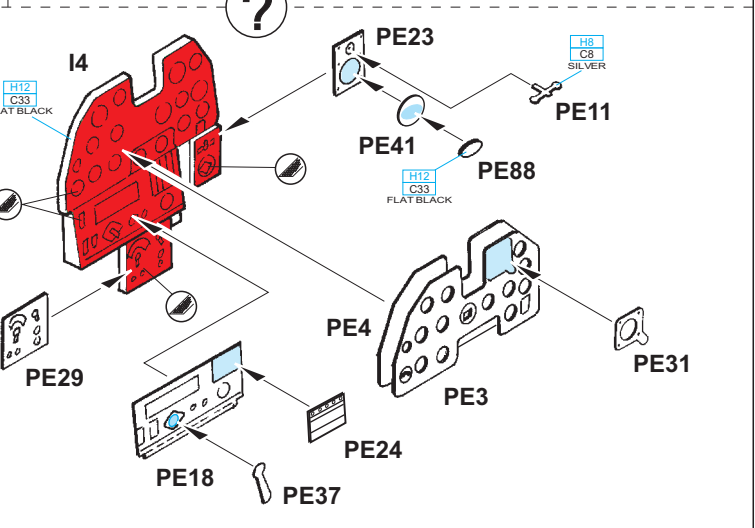
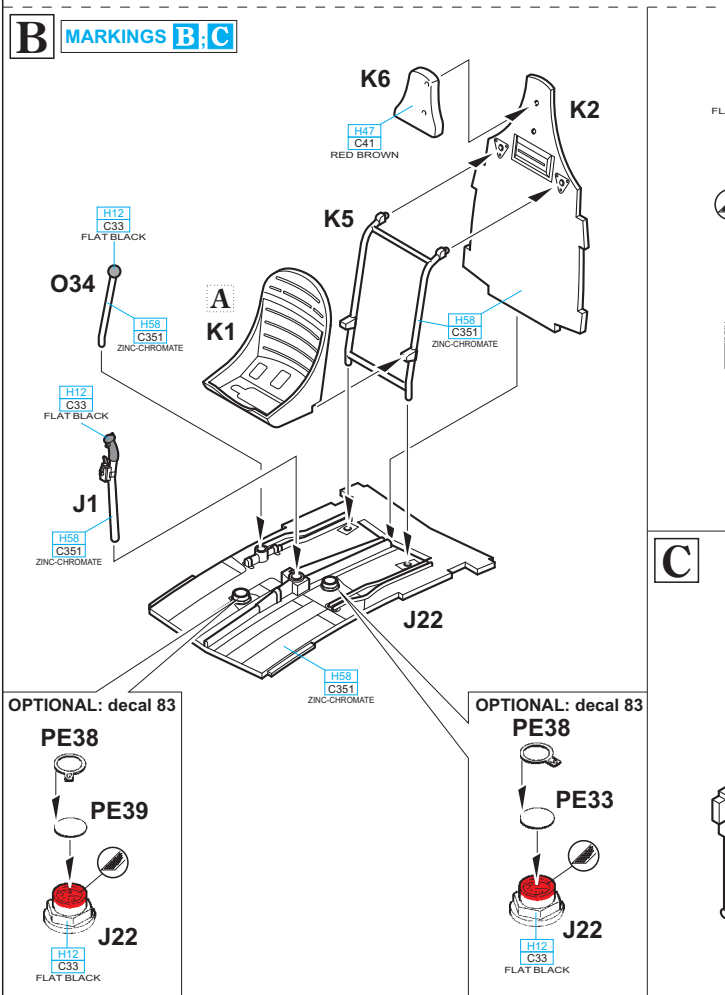
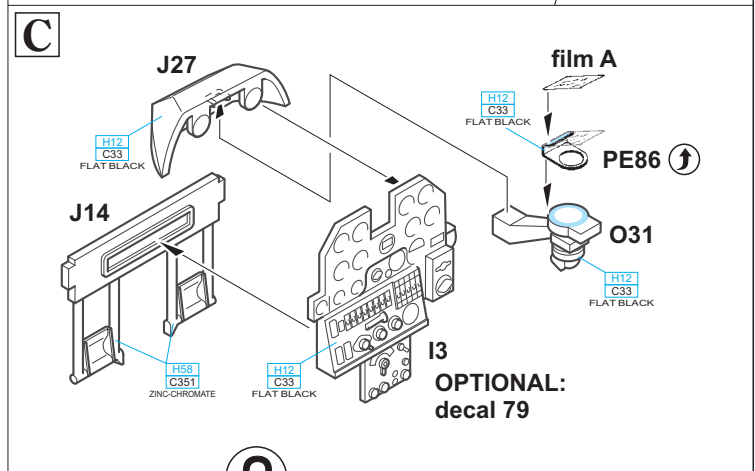
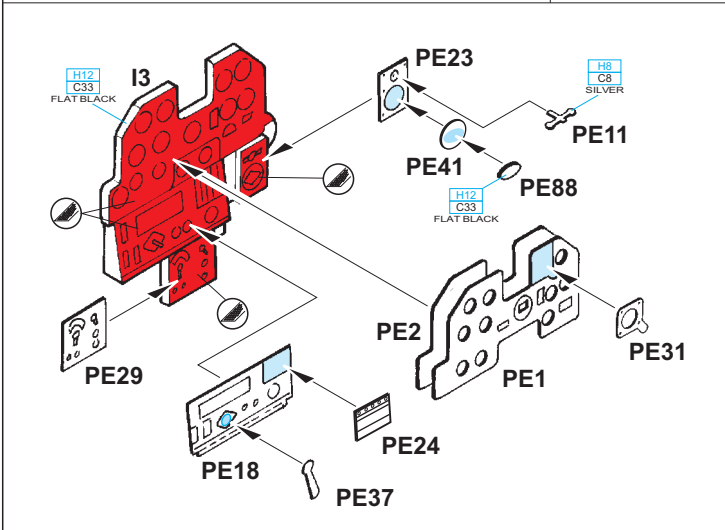
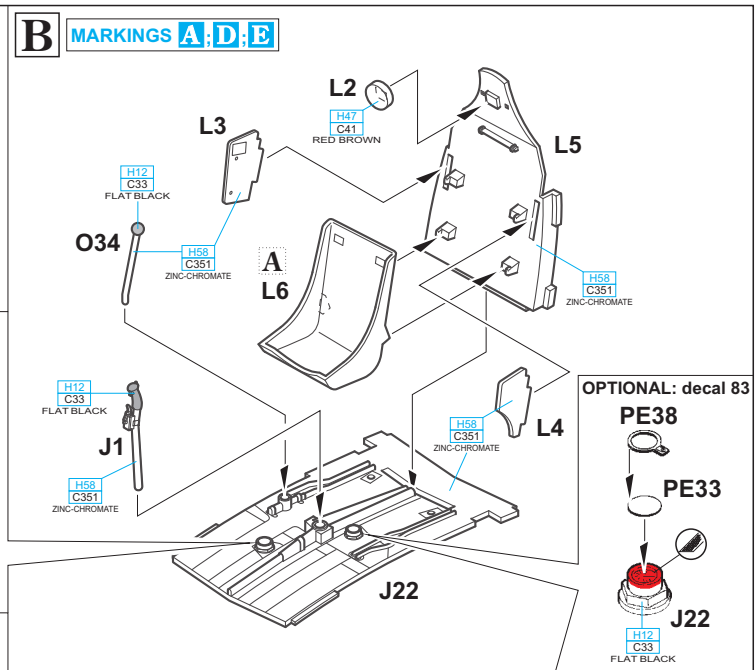
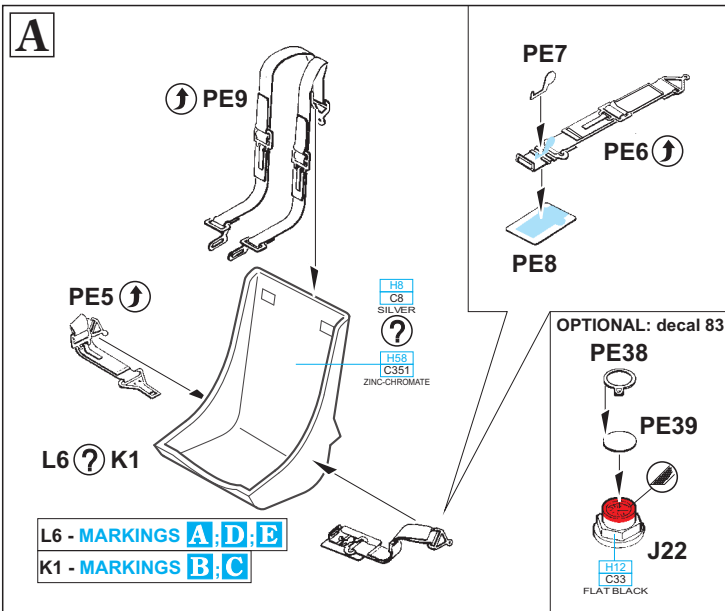

**D**

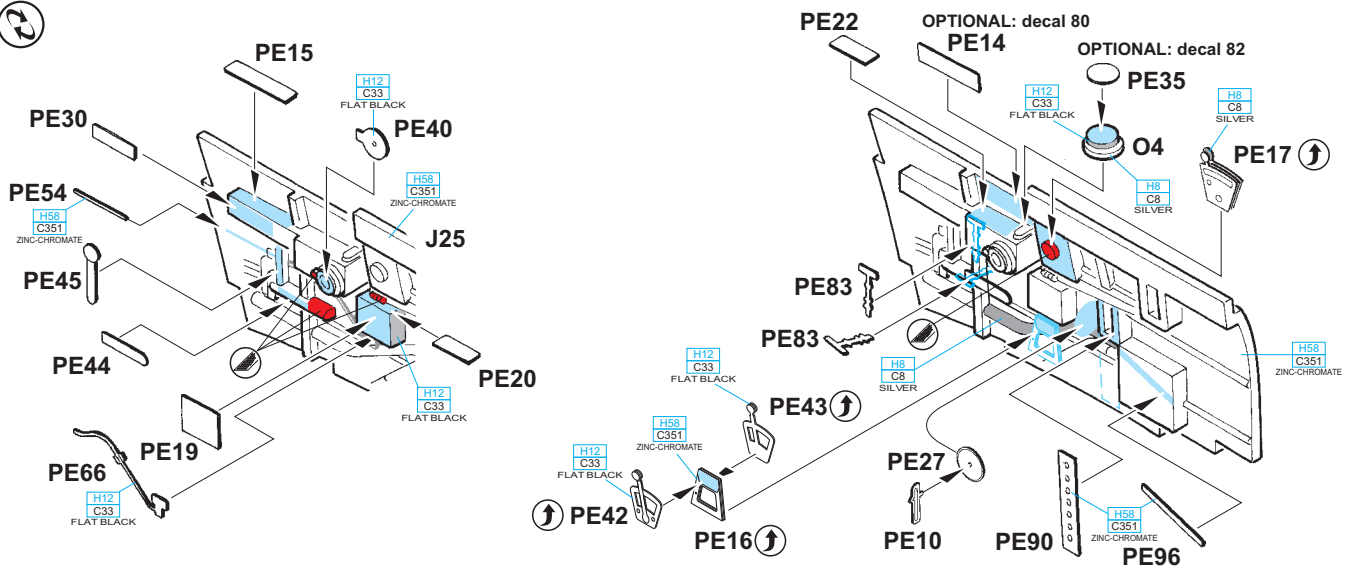

**E**

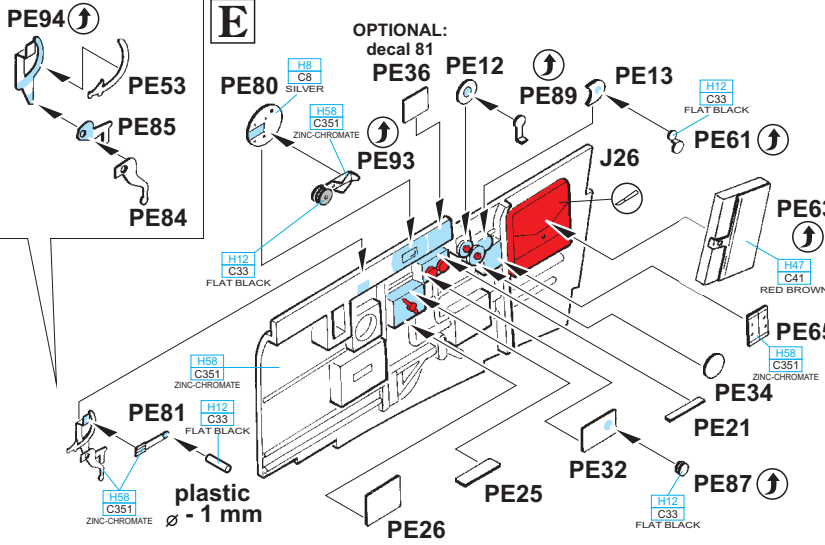

**F**

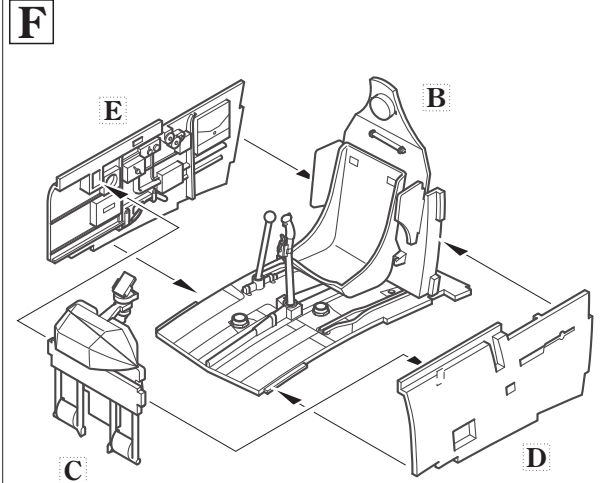

**Z3**

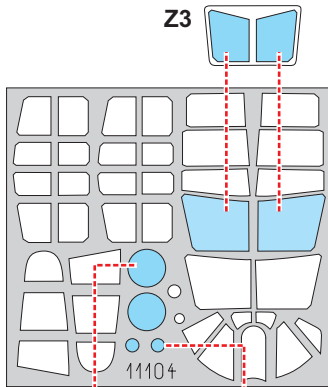

**RP18**  
2 pcs.

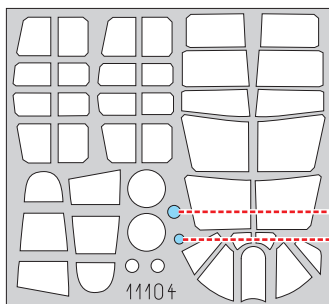
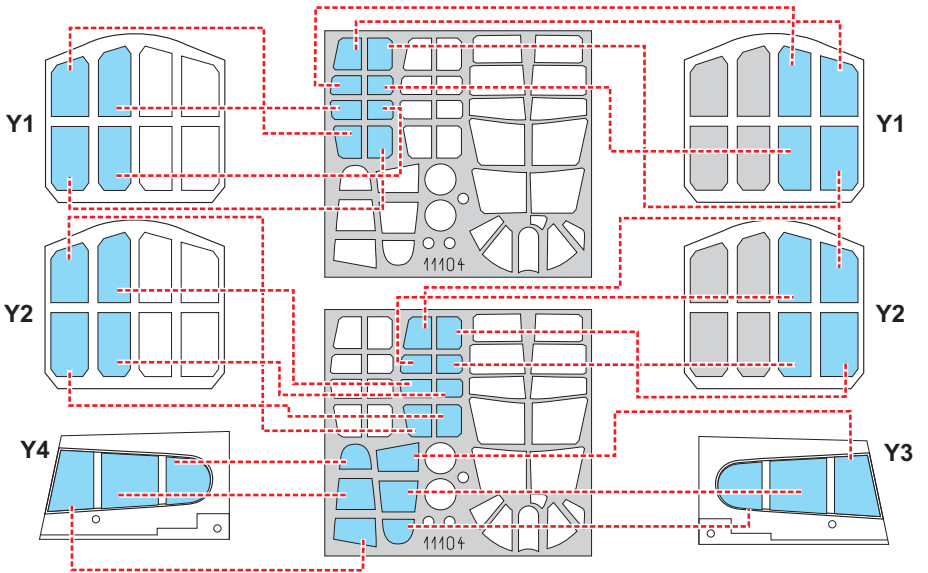
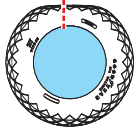

**V5**  
**V6**

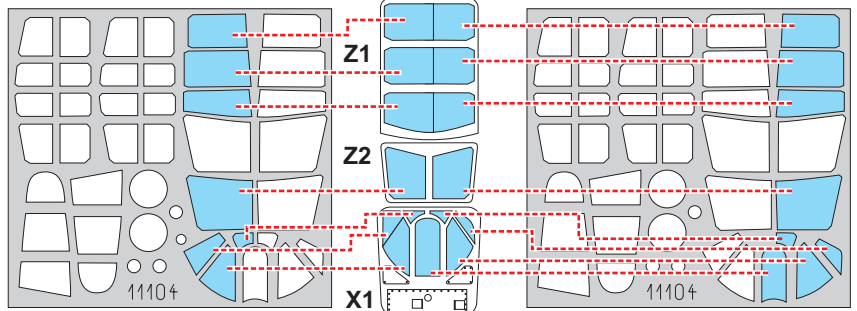

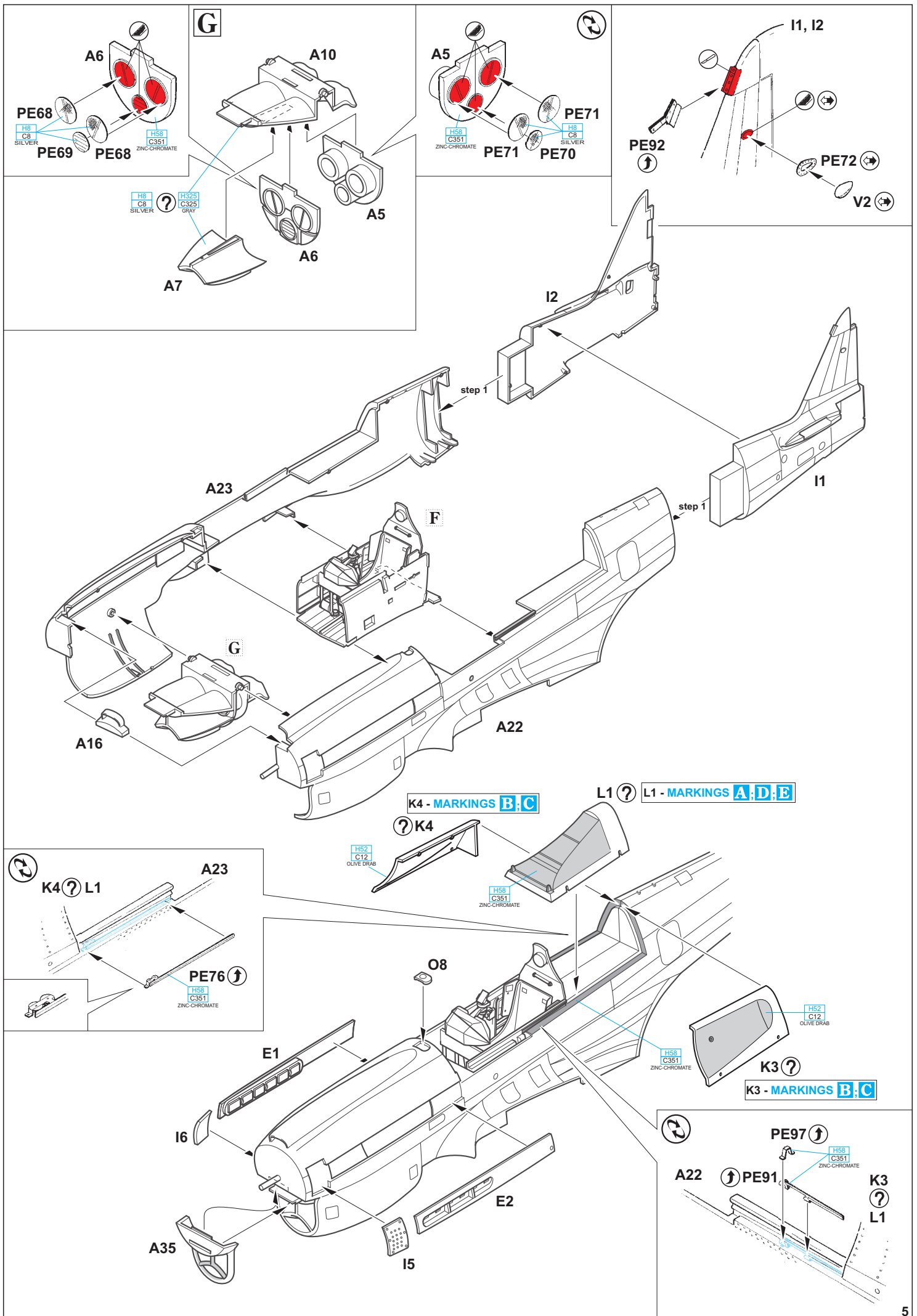

**G**

**A6**  
**PE68**  
 H8 C8 SILVER  
**PE69** **PE68**  
 H58 C351 ZINC-CHROMATE

**A5**  
 H58 C351 ZINC-CHROMATE  
**PE71** **PE70**  
 H8 C8 SILVER

**I1, I2**  
**PE92**  
**PE72**  
**V2**

H8 C8 SILVER ?  
 H325 C325 GRAY

**K4 - MARKINGS B:C**

**L1 ? L1 - MARKINGS A:D:E**

**K4 ? L1**  
**A23**  
**PE76**  
 H58 C351 ZINC-CHROMATE

H52 C12 OLIVE DRAB

H58 C351 ZINC-CHROMATE

H52 C12 OLIVE DRAB

H58 C351 ZINC-CHROMATE

**K3 - MARKINGS B:C**

**PE97**  
 H58 C351 ZINC-CHROMATE  
**A22** **PE91**  
**K3 ? L1**

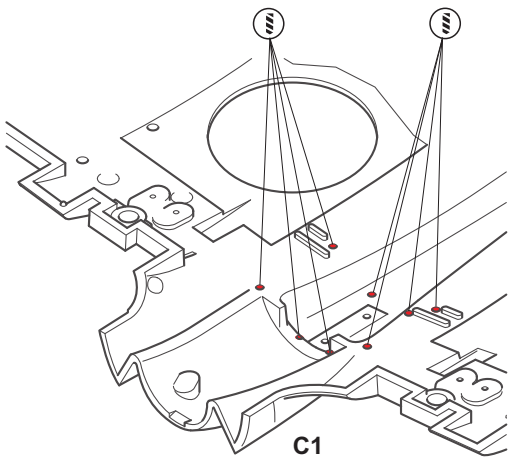

C1

**H**

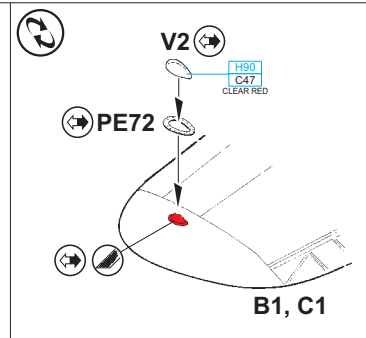
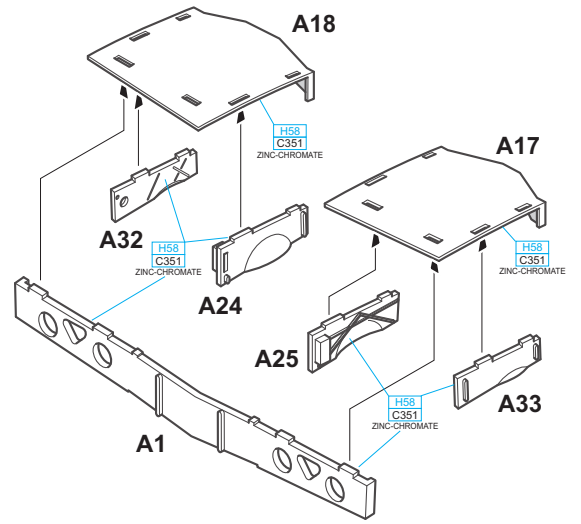

B1, C1

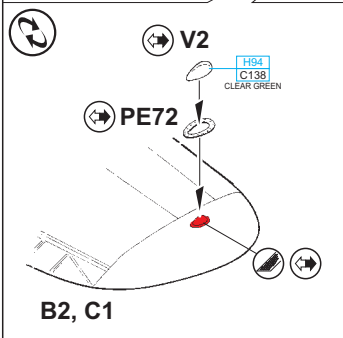

B2, C1

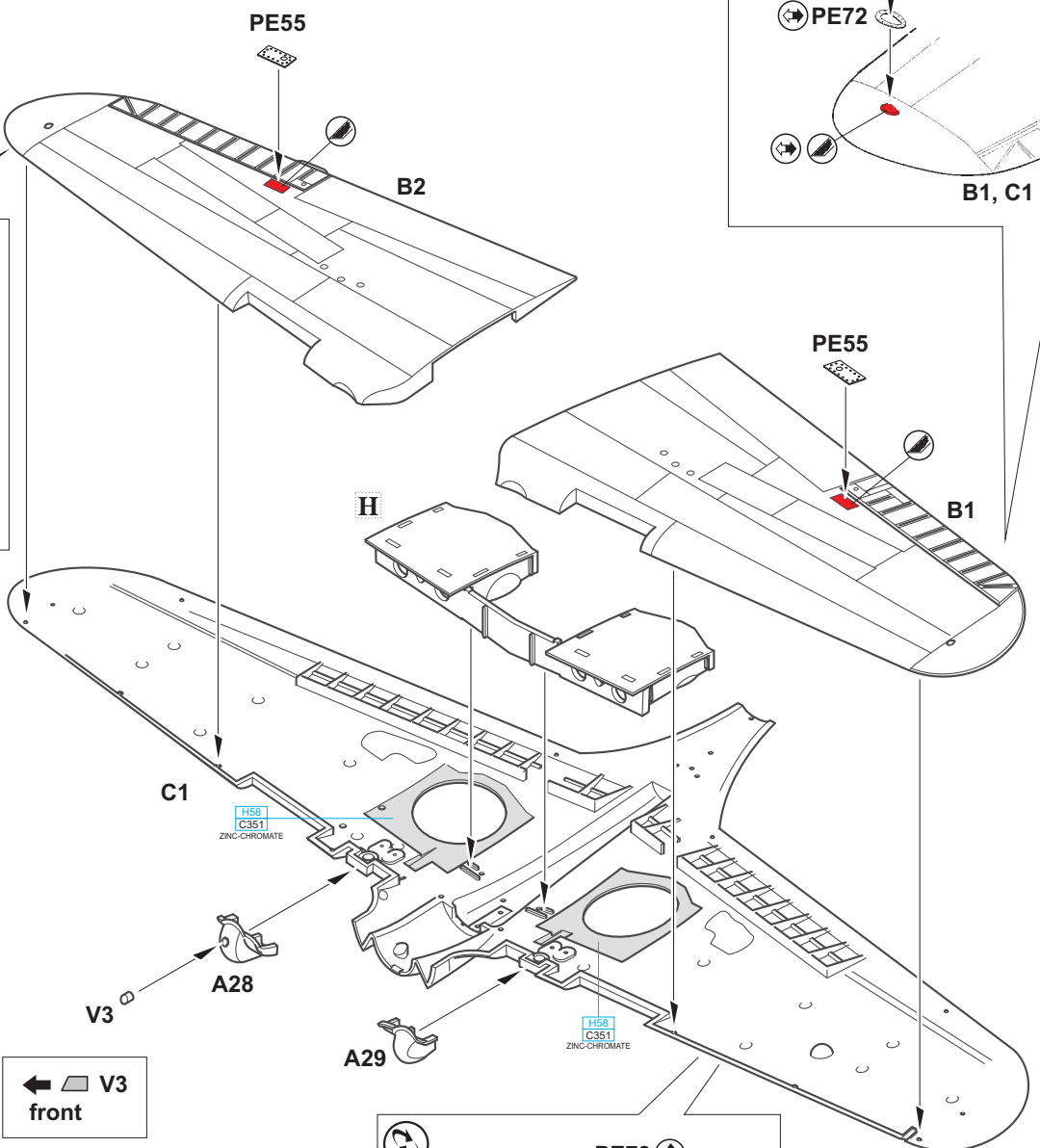

← V3  
front

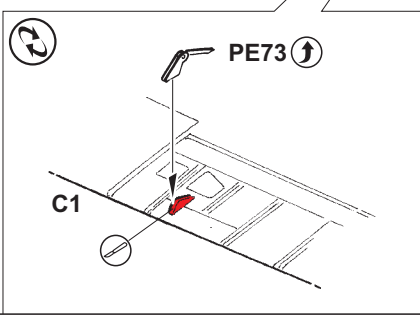

C1

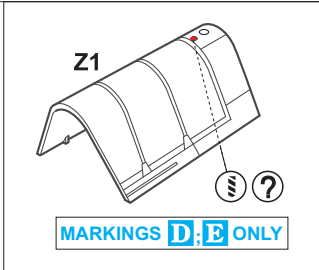
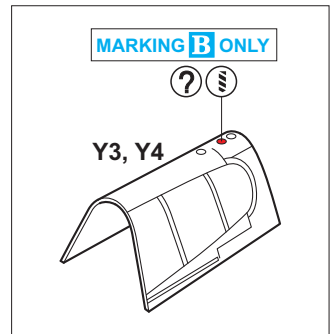
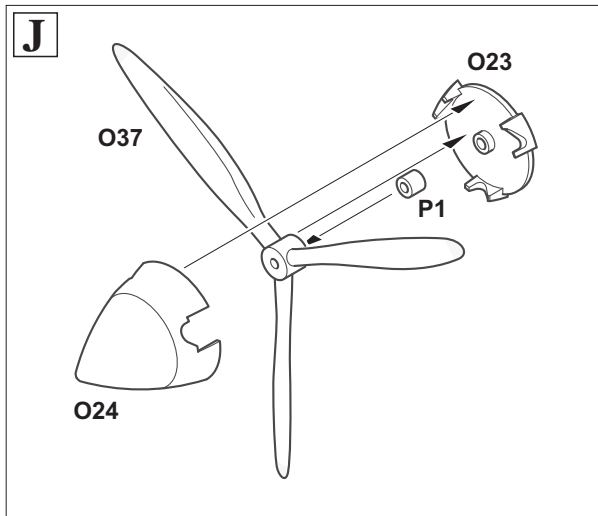
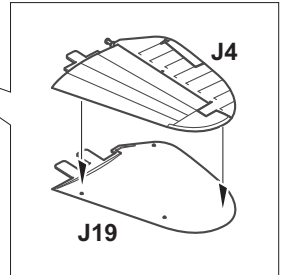
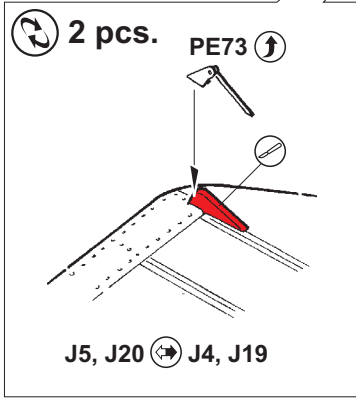
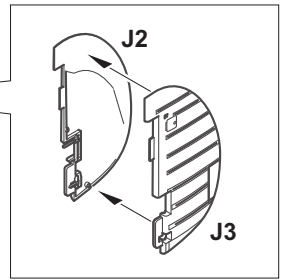
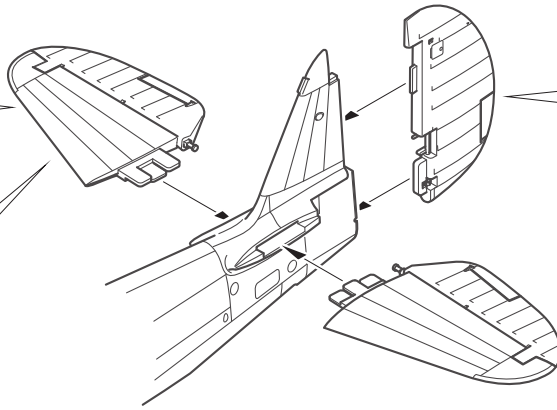
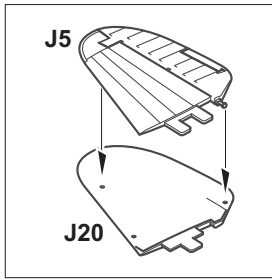

Z1 - MARKINGS A; D; E ONLY

Y3, Y4 - MARKINGS B; C ONLY

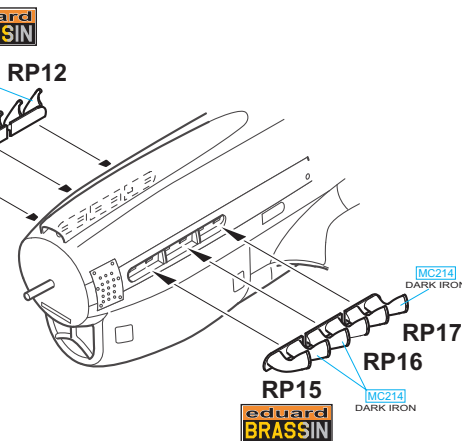
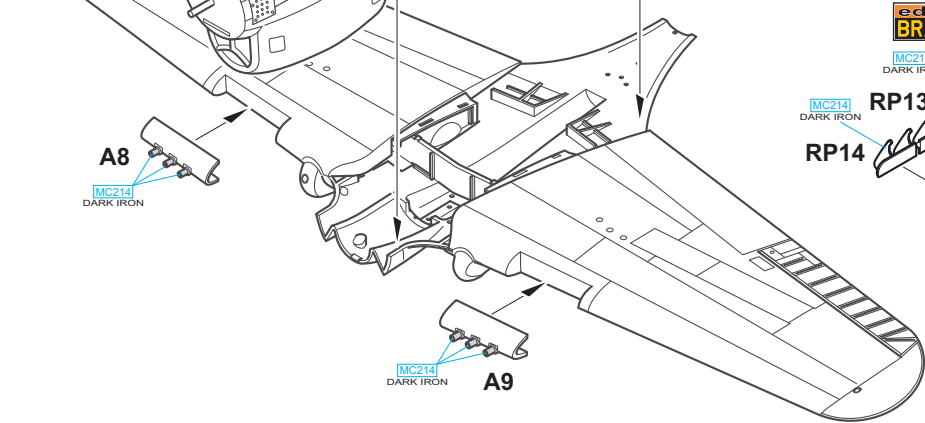
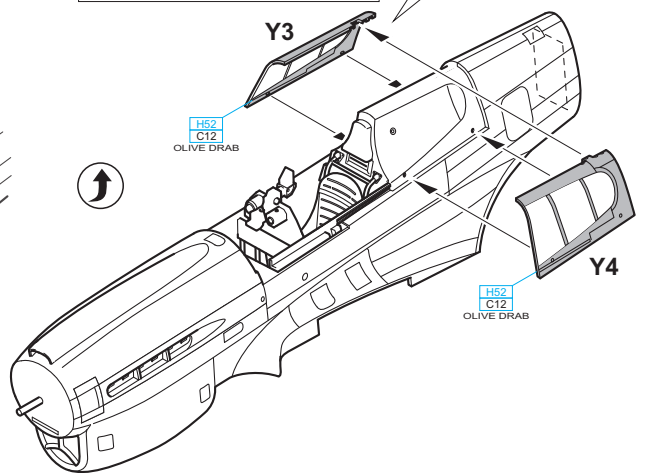
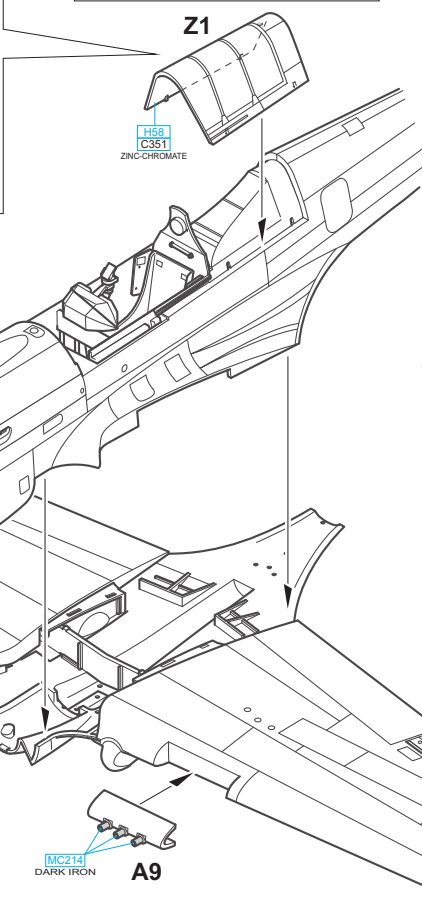

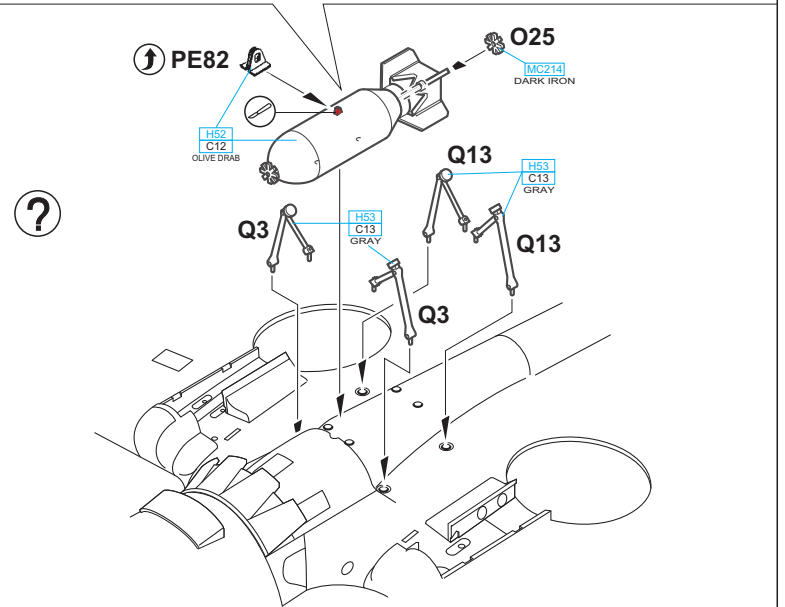
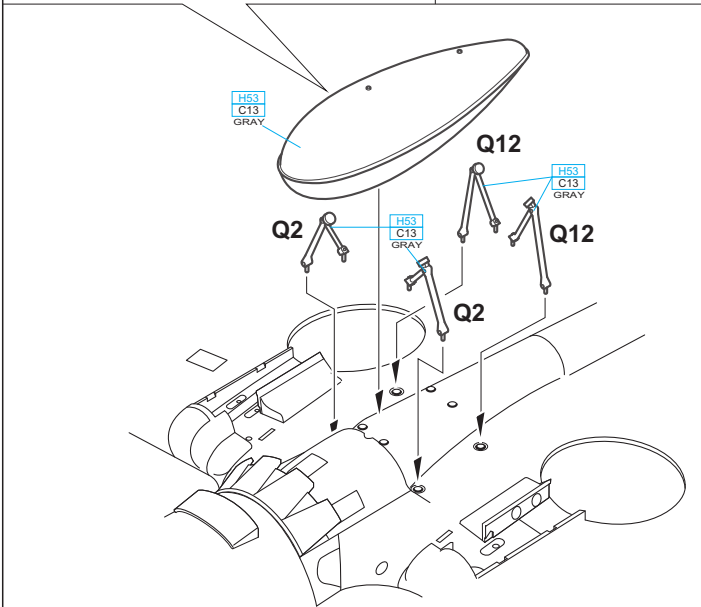
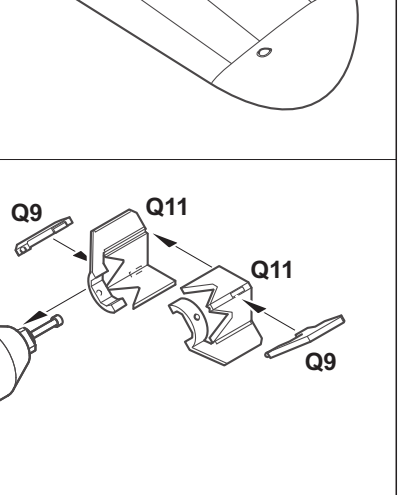
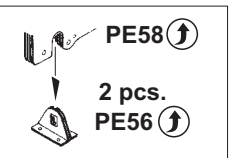
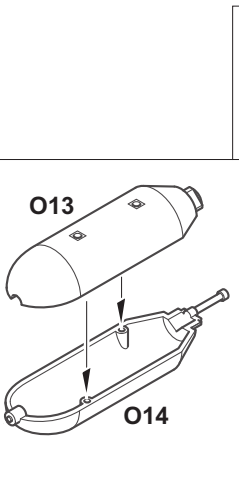
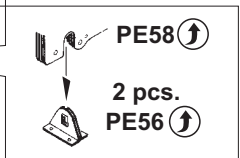
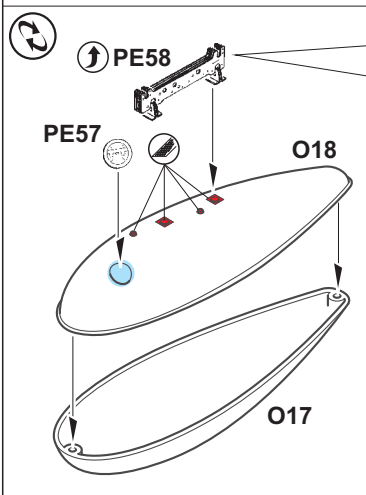
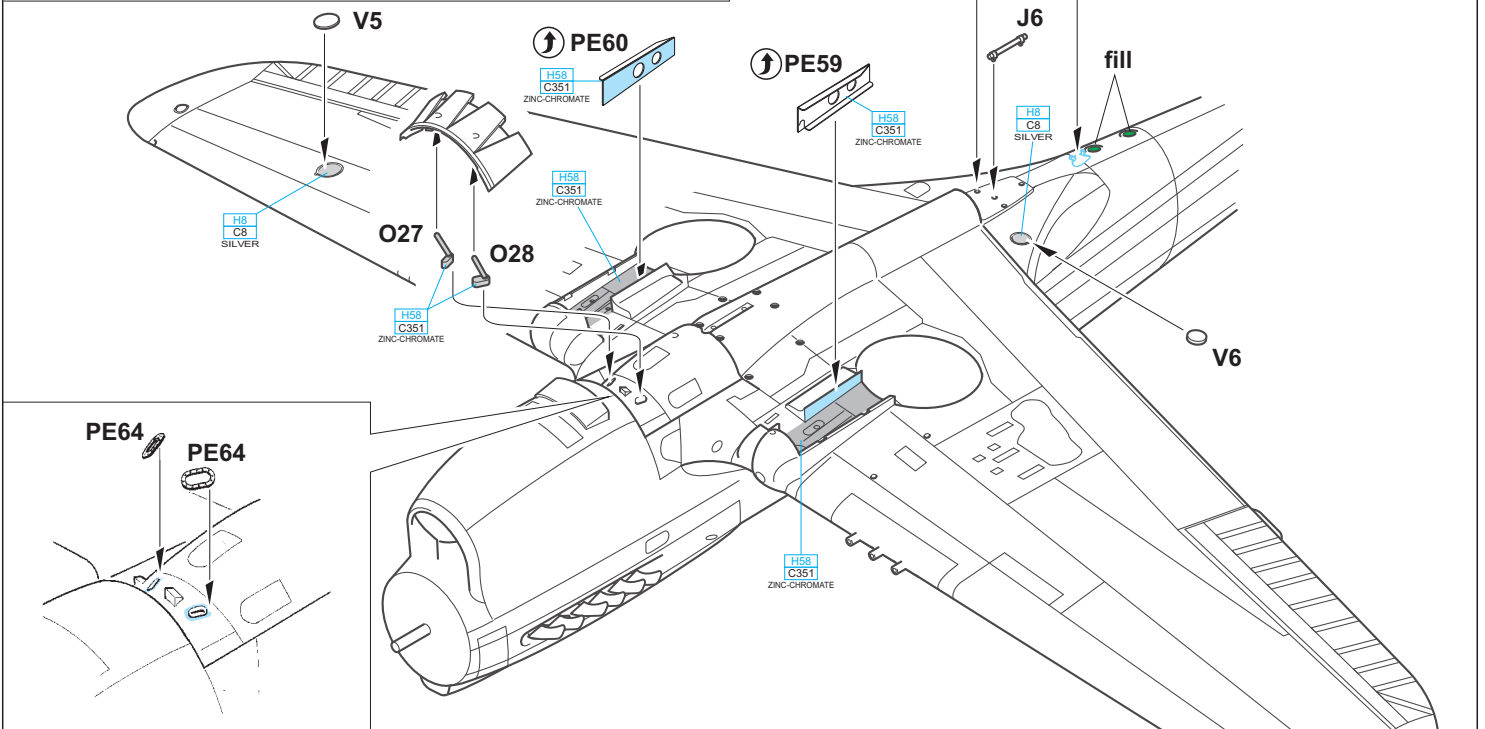
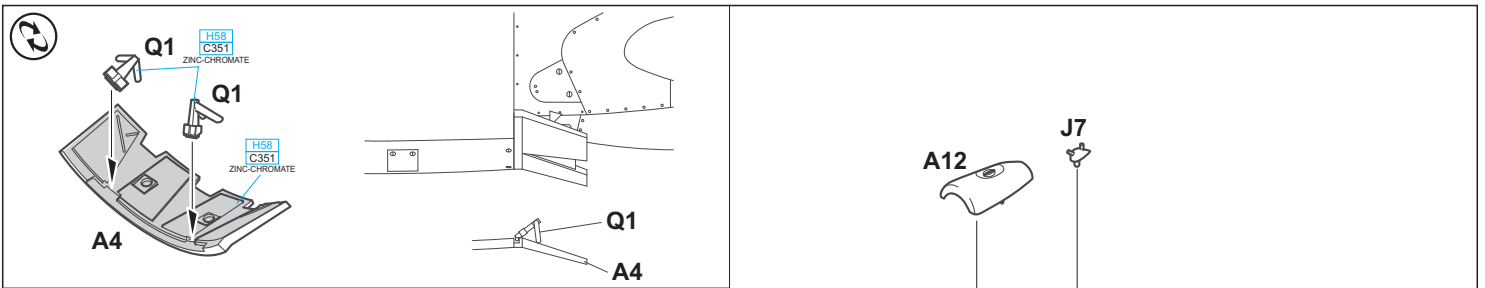



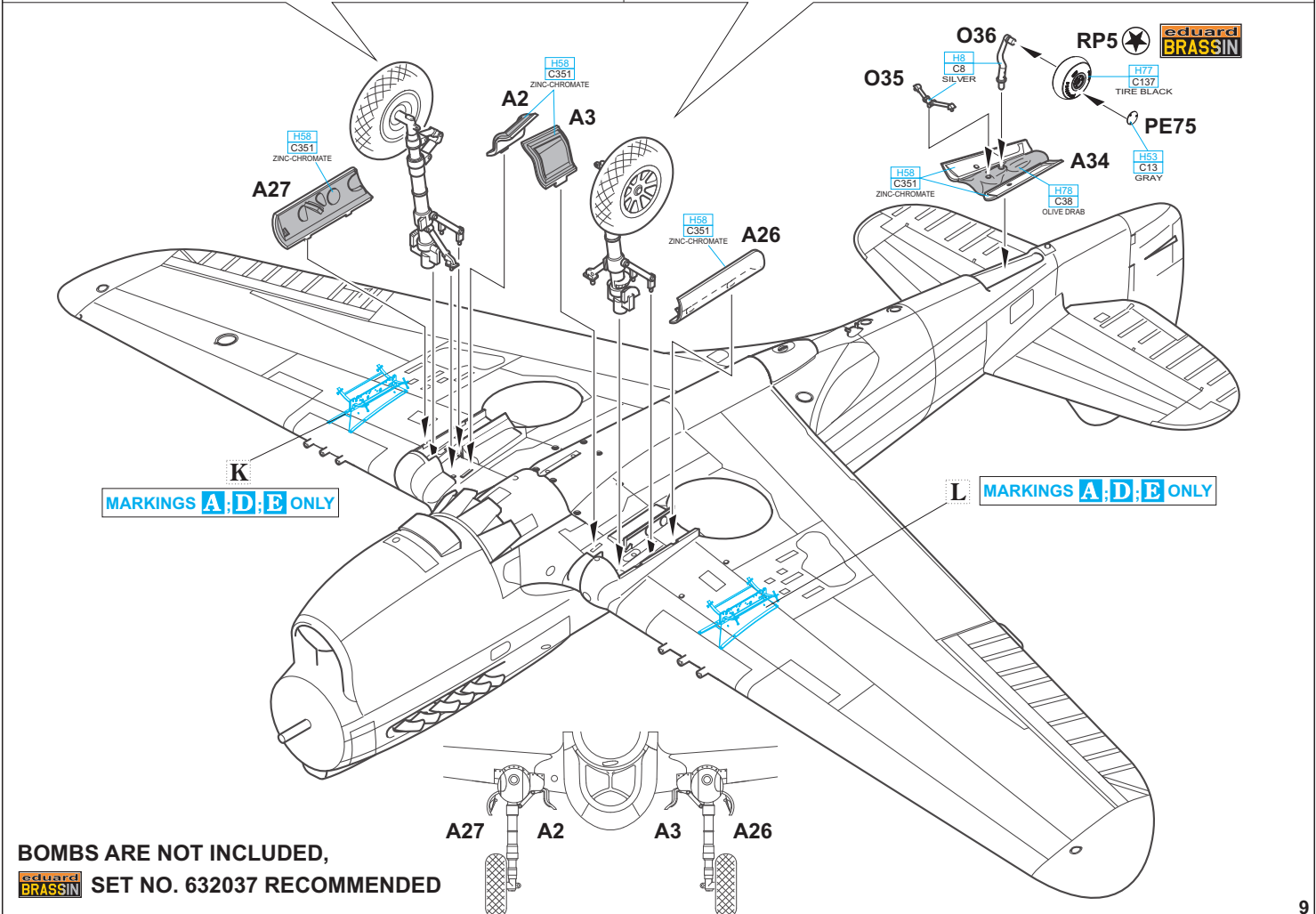
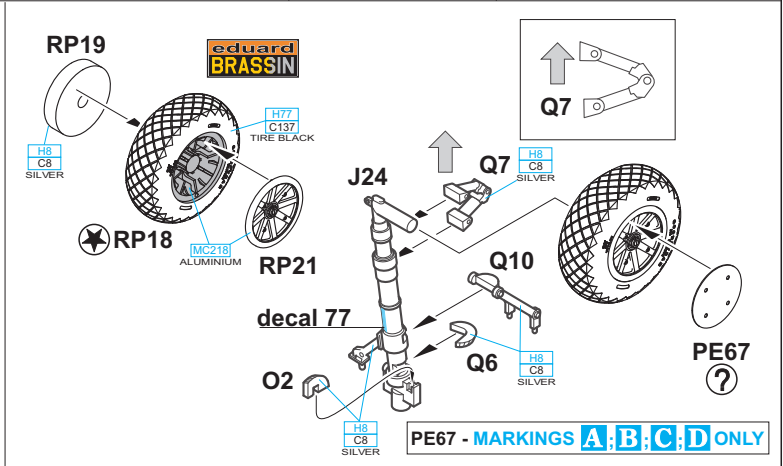
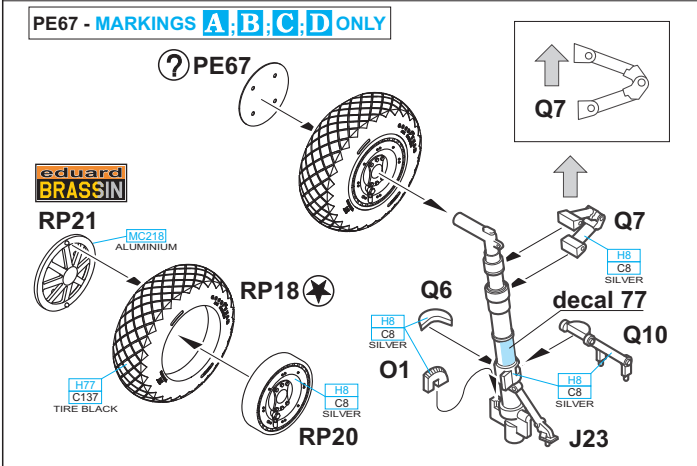
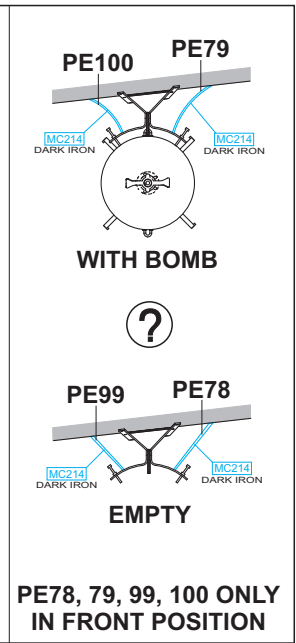
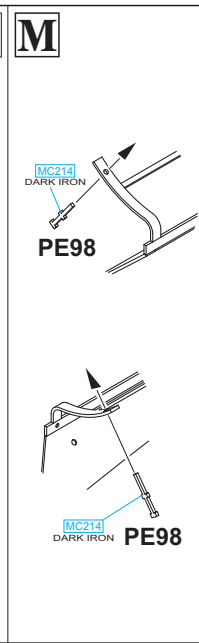
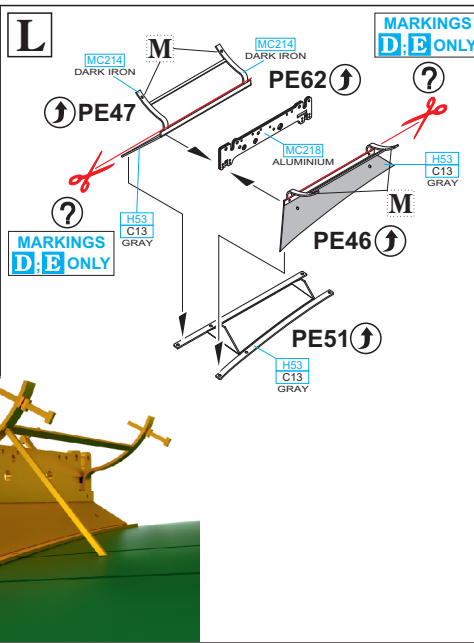
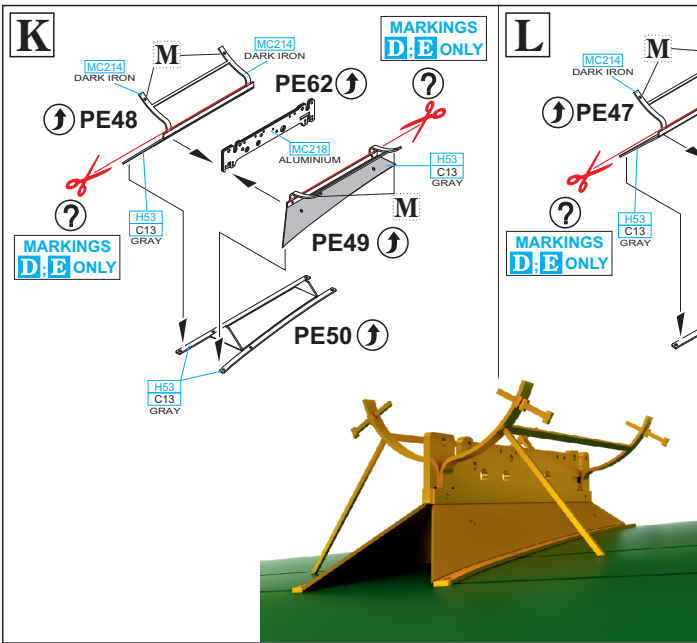

BOMBS ARE NOT INCLUDED,  
eduard BRASSIN SET NO. 632037 RECOMMENDED

PE28 - MARKINGS  
A; B; D; E ONLY

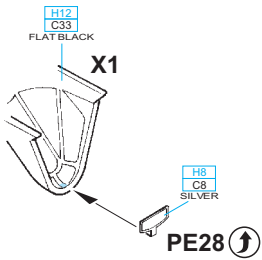

?

MARKINGS A; D; E ONLY

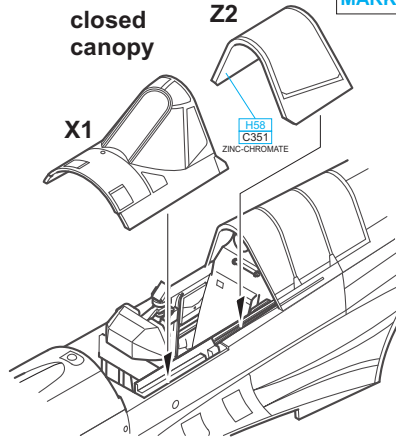

?

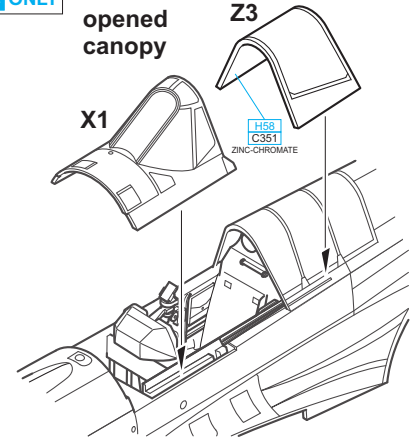

?

A19 - MARKING C ONLY

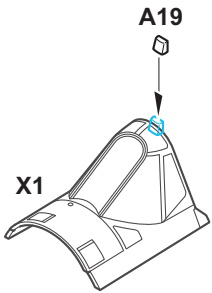

?

MARKINGS B; C ONLY

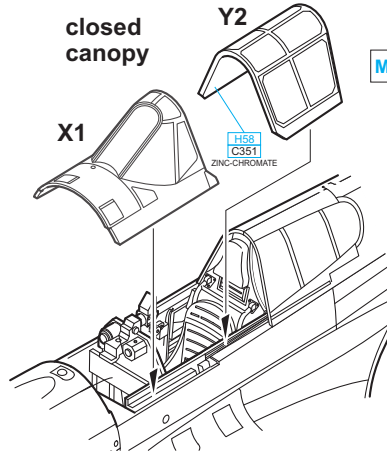

?

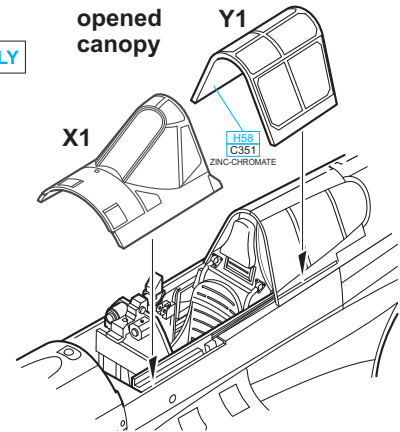

?

A14, O10 - MARKING C ONLY

O20 - MARKINGS B; D; E ONLY

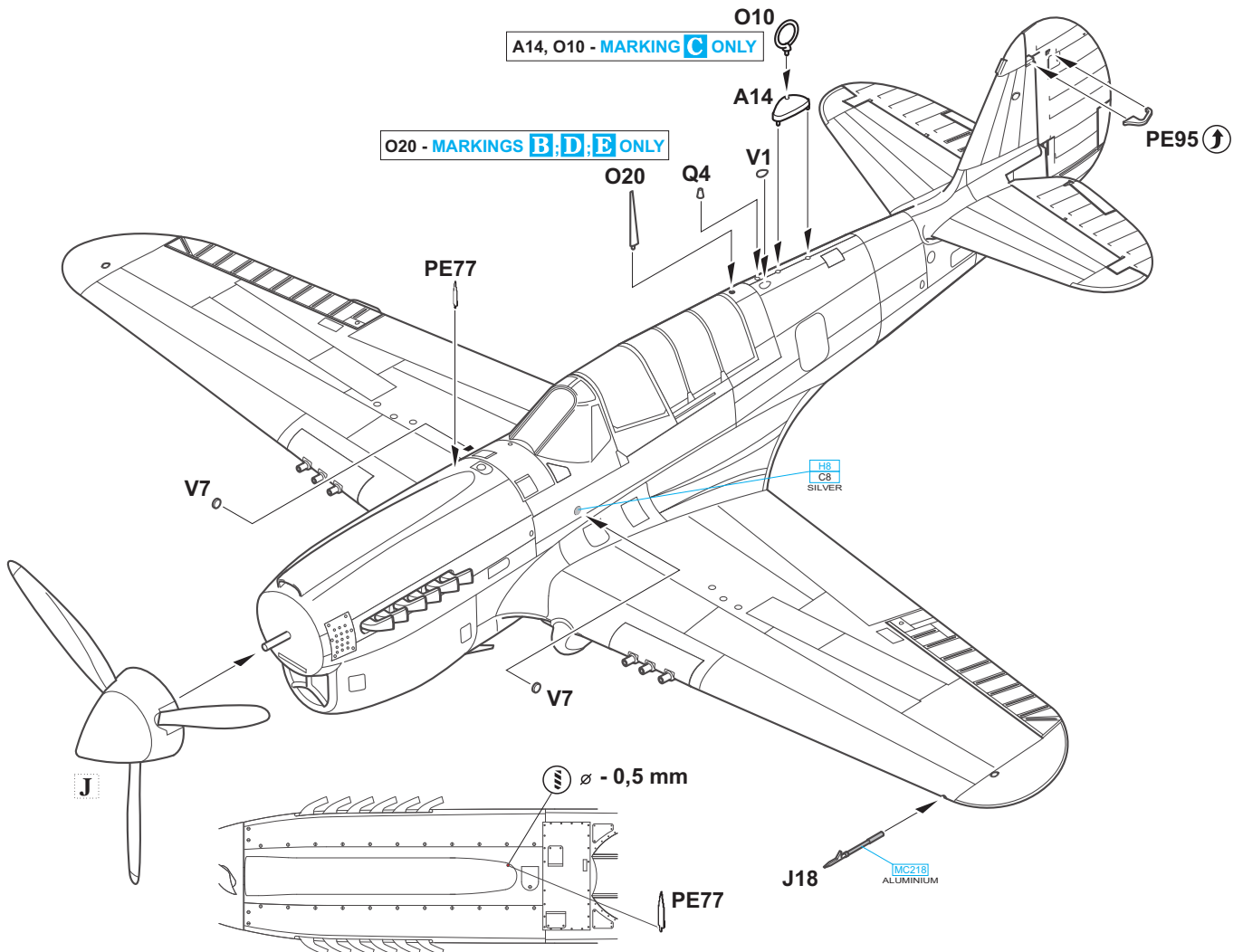

# A P-40N-5 s/n 42-105128 flown by Lt. P. S. Adair, 89th FS, 80th FG, Nagaghuli, India, February 1944

Philip Adair fought with the 80th FG eighteen months during 1943 and 1944. He flew 139 combat missions in the CBI Theatre of Operations. Probably his most memorable result came on December 13th, 1943, when he took off in defence of his home field against a Japanese raid. The interception of the raid was not only the goal of the 89th FS, but also the 88th FS and the 311th FBG, but Adair was not able to locate his colleagues in the air. He attacked the incoming Japanese bombers alone. On landing, he claimed one Japanese fighter destroyed, with two bombers and a fighter damaged. He did this while flying a P-40N-1, also named 'Lulu Belle', and was awarded the Silver Star for his actions. At the beginning of 1944 Philip Adair was assigned this aircraft, again named 'Lulu Belle'. On May 17th, 1944, while attacking ground targets, he was met by fighters identified as Oscars. He shot down two of them. The 204th Sentai however claimed no losses, and in fact claimed the shooting down of the entire four ship flight that was led by Adair. Adair flew the P-40N until June 1944, when the unit began to re-equip with the P-47D Thunderbolt.

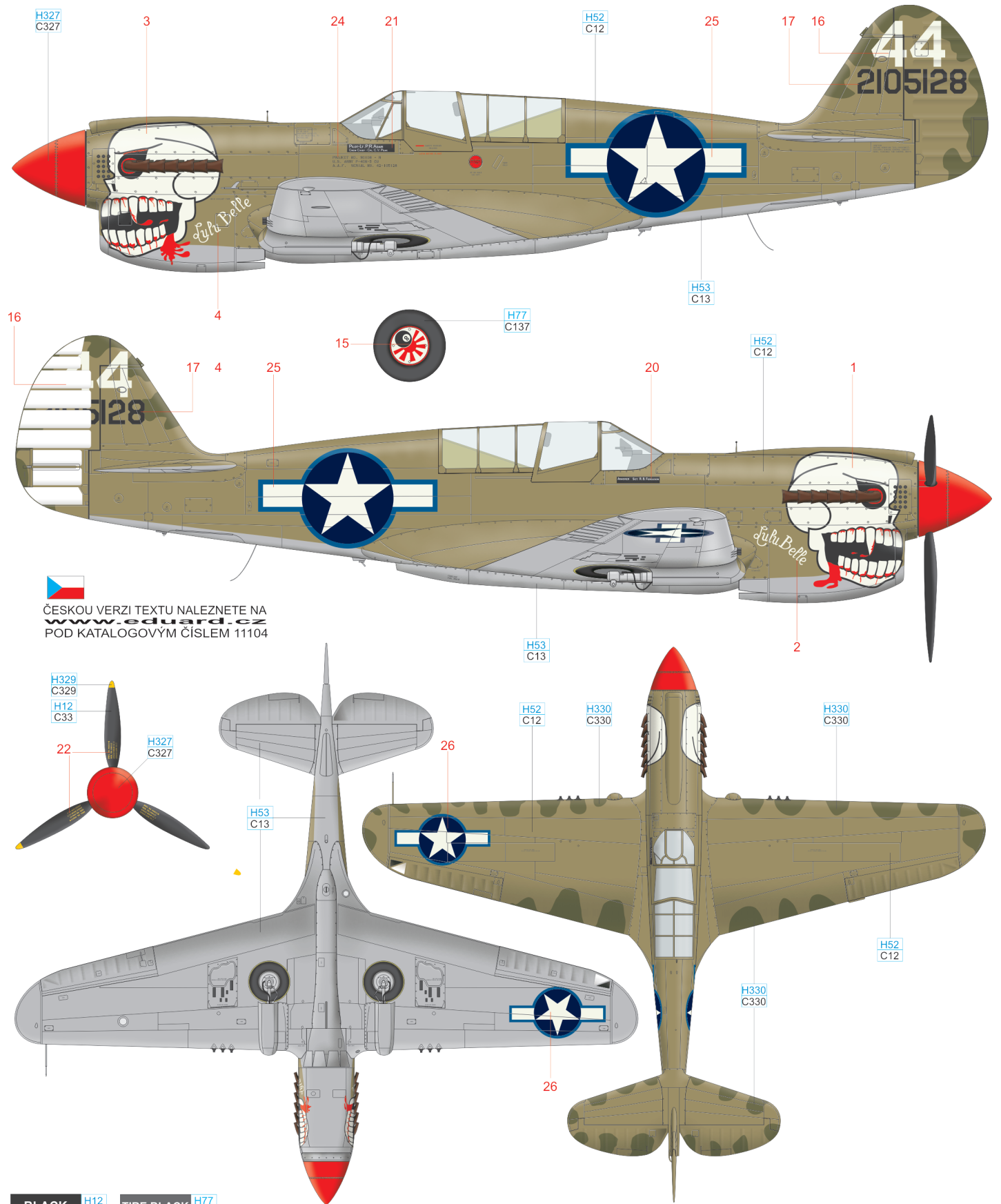

ČESKOU VERZI TEXTU NALEZNETE NA [www.eduard.cz](http://www.eduard.cz) POD KATALOGOVÝM ČÍSEM 11104

<b>BLACK</b>	H12 C33	<b>TIRE BLACK</b>	H77 C137
<b>YELLOW</b>	H329 C329	<b>GREY</b>	H53 C13
		<b>OLIVE DRAB</b>	H52 C12
		<b>DARK GREEN</b>	H330 C330
		<b>RED</b>	H327 C327

# B Kittyhawk IV (P-40N-1), NZ3148, No. 18 Squadron RNZAF, Ondonga, New Georgia, November 1943

The name 'Gloria Lyons' came from correspondence between two armourers at No.4 Servicing Unit based at the time on New Georgia and a tuberculosis patient with that name, hospitalized in Christchurch. Her name appeared progressively on three Kittyhawk IVs of the New Zealand Air Force. Aircraft serialied NZ3148 was the first so named and flew combat with the No. 18 Squadron, RNZAF. It was written off on February 9th, 1944, when on landing at the Torokina airfield on Bougainville, the engine cut out, and Lt. Charles Woods went off the strip. He escaped injury in the mishap. The aircraft was in its original American camouflage scheme, the upper and side surfaces being Olive Drab with Neutral Grey undersides. The American national insignia was replaced by New Zealand markings. The white bands were quick identification markings of New Zealand aircraft operating in the Southwest Pacific area.

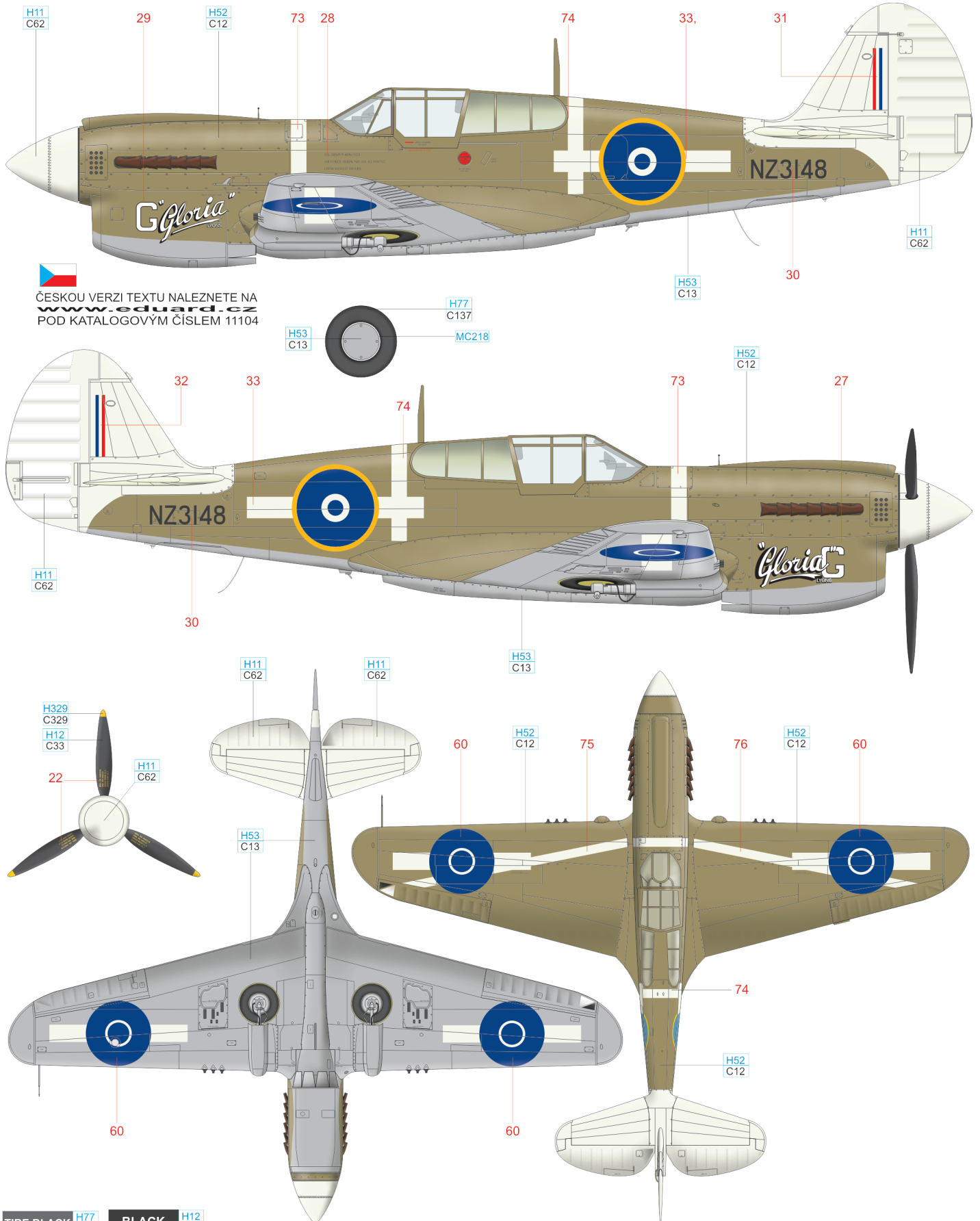

ČESKOU VERZI TEXTU NALEZNETE NA  
[www.eduard.cz](http://www.eduard.cz)  
 POD KATALOGOVÝM ČÍSLEM 11104

TIRE BLACK	H77 C137	BLACK	H12 C33
WHITE	H11 C62	YELLOW	H329 C329
		GREY	H53 C13
		OLIVE DRAB	H52 C12
		ALUMINIUM	MC218

# C P-40N-1 flown by Lt. G. L. Walston, 16th FS, 51st FG, Kunming, China, 1944

'Bud' Watson flew a total of 215 hours while serving in China. This number included 67 combat missions, often as a Flight Leader, and sometimes even of the entire squadron. Frequent targets for the 51st FG were enemy airfields, which allowed Walston to claim six destroyed bombers and another six damaged. In aerial combat, he also claimed one kill and another damaged. The Warhawk named 'Ruth A' was one of several Curtiss P-40s that Walston flew in combat. The depiction here illustrates the aircraft as it appeared prior to a forced landing in the summer of 1944, after which, among other changes, the aircraft received a new radiator cover. The new panels carried a different sharkmouth. The camouflage paint was touched up in many spots with a noticeably darker shade of green, and on the engine cowl, the paint had worn to bare metal. The aircraft lacked the national insignia on the top of the left wing.

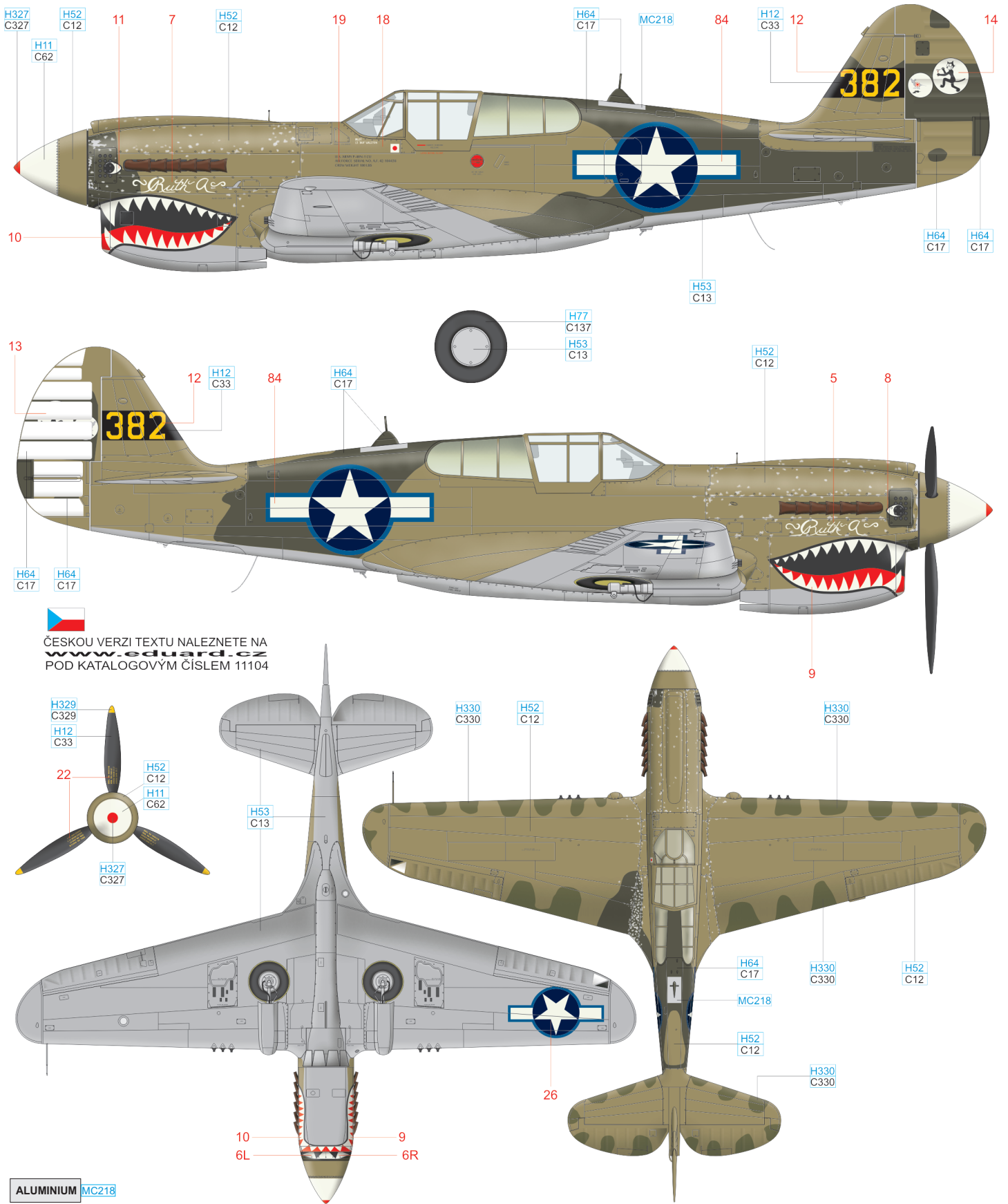

ČESKOU VERZI TEXTU NALEZNETE NA  
[www.eduard.cz](http://www.eduard.cz)  
 POD KATALOGOVÝM ČÍSLEM 11104

ALUMINIUM	MC218												
TIRE BLACK	H77 C137	BLACK	H12 C33										
WHITE	H11 C62	YELLOW	H329 C329	GREY	H53 C13	OLIVE DRAB	H52 C12	DARK GREEN	H330 C330	DARK GREEN	H64 C17	RED	H327 C327

# D P-40N, 7th FS, 49th FG, Cyclops Airfield, Hollandia, New Guinea, May 1944

Warhawks of the 49th FG were well known for their noseart, with scantily clad ladies being quite popular. The author of many of these was John Dunne. The aircraft with the port side inscription 'Daddy Please' and starboard side 'Milk Wagon Express' served with the 49th FG from the summer of 1943. Initially, the tactical number '10' was carried, which during the course of its career was changed to '00'. Although the name of the plane's pilot is not known, the number from 0 to 10 suggests, that it was someone from the command structure of the 49th FG. In the summer of 1944, the aircraft was transferred to the 82nd Tactical Reconnaissance Squadron, operating under the 71st TRG, and flew combat missions out of Biak Atoll. At that time, the spinner became yellow. The white leading edges of the wings were a quick recognition aid of friendly aircraft, a practice started by the 5th AF in the summer of '43.

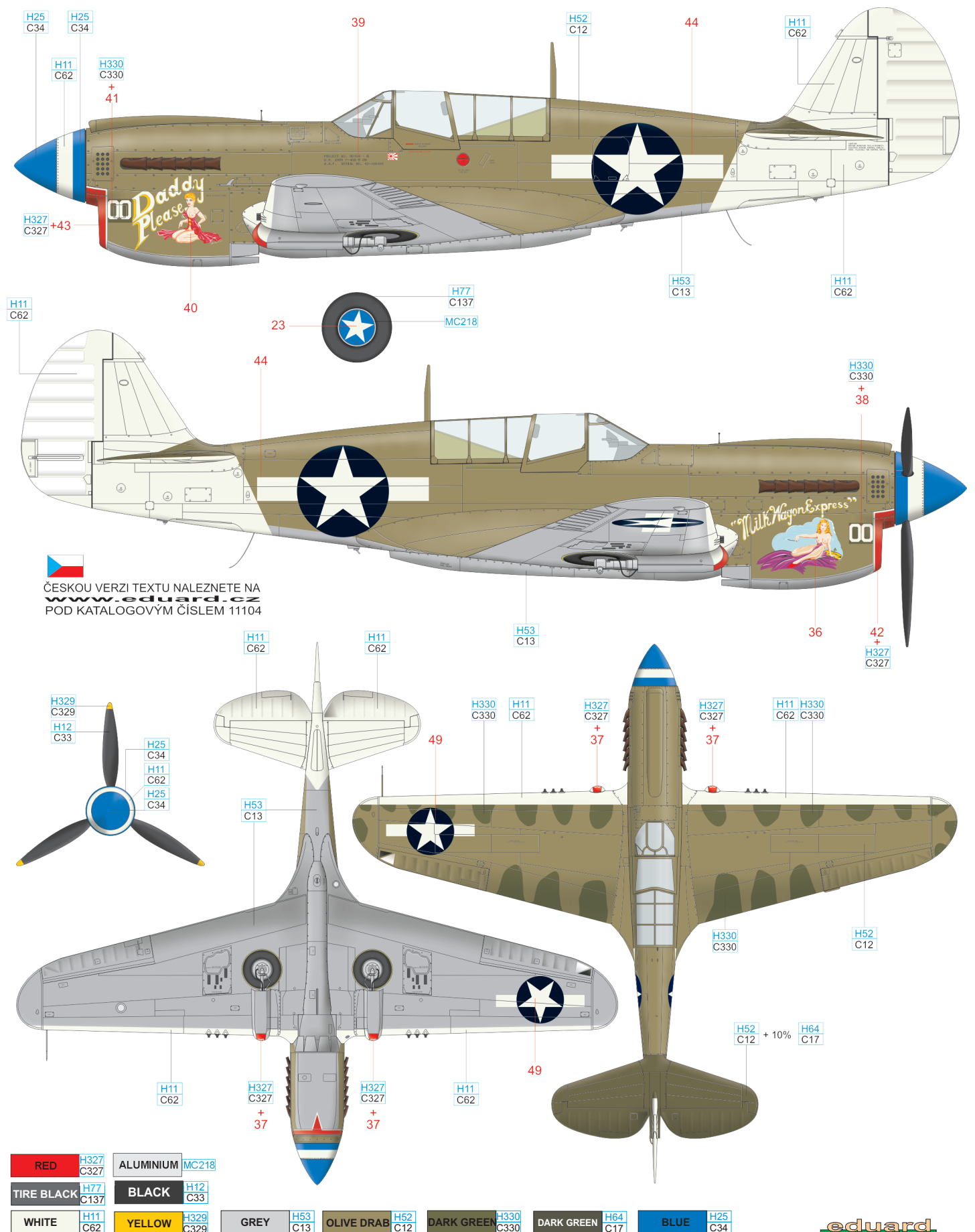

ČESKOU VERZI TEXTU NALEZNETE NA  
[www.eduard.cz](http://www.eduard.cz)  
 POD KATALOGOVÝM ČÍSLEM 11104

# E Kittyhawk IV (P-40N-20), NZ3220, No. 18 Squadron RNZAF, Bougainville, 1944

Kittyhawk NZ3220 was the third New Zealand Air Force P-40N to carry the name 'Gloria Lyons' on the nose. The second of the so named aircraft, serialied NZ3167, was lost on February 22th, 1944 (thirteen days after first 'Gloria Lyons' Kittyhawk NZ3148, was lost with the same pilot at the controls!), when the gear retraction mechanism was rendered useless during a raid on a Japanese base and the pilot had to bail out over water off the island of Buka. The look of the inscription 'Gloria Lyons' on NZ3220 differed from its two predecessors. Below the windscreen, there were 2.5 kill marks and bombing mission markers in the form of yellow bomb silhouettes.

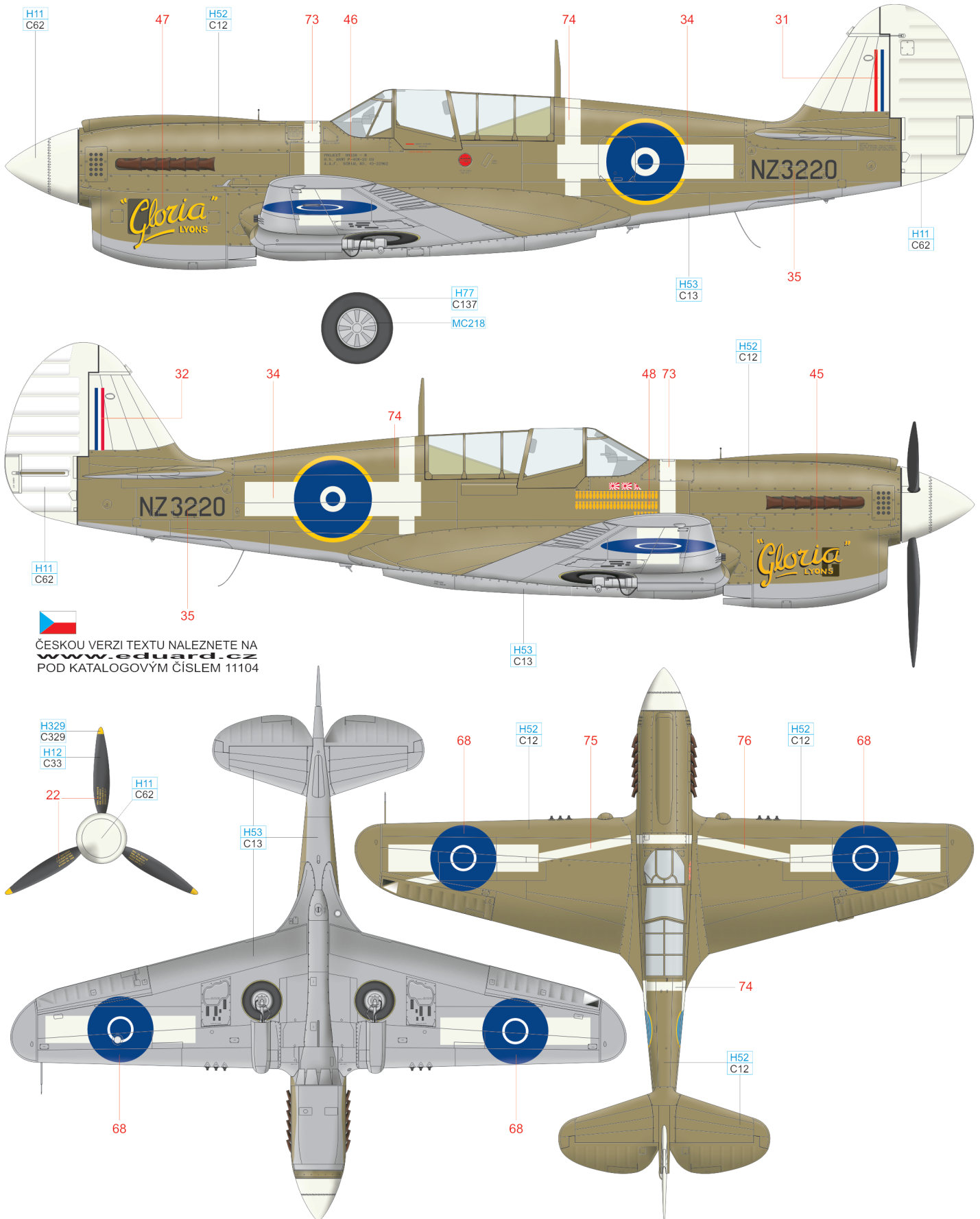

ČESKOU VERZI TEXTU NALEZNETE NA [www.eduard.cz](http://www.eduard.cz) POD KATALOGOVÝM ČÍSLEM 11104

TIRE BLACK	H77 C137	BLACK	H12 C33
WHITE	H11 C62	YELLOW	H329 C329
		GREY	H53 C13
		OLIVE DRAB	H52 C12
		ALUMINIUM	MC218

