

# P-51D-10 Mustang™

eduard

1/48 Scale Plastic Model Kit



Produced under license

Boeing, P-51 Mustang, their distinctive logos, product markings and trade dress are trademarks of The Boeing Company.

**WEEKEND**  
edition



item # 84184

**The P-51 Mustang is one of the best fighters of all time and although an American design, its genesis owes a lot to Great Britain.**

It started in 1940, when British Buying Committee asked North American Aviation (NAA) to build the Curtiss P-40s for the RAF. NAA president James Kindelberger offered Britons the development of a much better plane instead. Britons agreed and the design team led by chief designer Edward Schmued, who was a German immigrant with Austrian roots, started to work. The preliminary design was approved on May 4, 1940, final assembly and engine installation began on September 9 (just 127 days after approval) and the first flight of the NA-73X prototype followed on October 26.

#### Innovative fighter

The Allison V-1710-39 one-stage, one-speed supercharged liquid cooled in-line engine rated at 1,100 HP was chosen for the new fighter and the designers creating as narrow and sleek a fuselage as possible did their best to lower the drag. For the same reason they decided to use an innovative laminar flow airfoil, which lowers the drag indeed, but, on the other hand, requires smooth surface. That necessitated to putty and sand the leading area of the wing. Another design novelty was the radiator belly under the fuselage. Armament consisted of two guns in the nose and four in the wings, all of them .50 caliber Brownings (the Mk. Ia variant had four 20mm cannons). Britons chose the name Mustang for the new aircraft, later adopted by US side as well. The RAF received the first Mustangs Mk.I in October, 1941. The performance was found satisfactory, as the Mustang was faster than the Spitfire Mk.V and had more than double the range. On the other side, the Allison engine reached its maximum power at only 11,800 ft (3597 m) because of its one stage supercharger. Above this level the engine performance decreased rapidly. As the aerial combats occurred much higher, the RAF decided to use their Mustangs in the reconnaissance role and the US Army Air Corps, interested in the new type as well (but bound to the contract to build P-40, P-39 and P-38 pursuits), asked the NAA to convert the Mustang as a dive bomber with wing dive brakes (the A-36 variant).

#### Merlin magic

To solve the high altitude weakness, the work began in Great Britain to fit the Mustang with the two-stage, two-speed supercharger Merlin 61 engine. The trials of the Mustang X prototype, fitted with Merlin 65 finally, found the level speed increased to 433 mph (697 km/h) at 22,000 ft (6,700 m), 100 mph (161 km/h) faster than Mustang Mk.I. As it was obviously the way to further develop the Mustang, NAA started its own work, using license built Packard-Merlin engine. The need of an intercooler for the two-stage supercharger necessitated a bigger radiator duct. Another change included the removal of the fuselage guns. The production started at the Inglewood plant as P-51B on May 1943 and at the new production line at NAA Dallas plant as P-51C in

August 1943. Also, the supplies to RAF continued as Mustang Mk. III. The P-51B/C were great fighters but lacked backward visibility and suffered with gun jamming. The RAF found some improvement to the visibility issue with a "Malcolm Hood" semi-bubble canopy, but the design team of NAA decided to rework the Mustang again. The main change was the bubble canopy with lowered rear fuselage. The wing was reworked to accommodate six .50 cal guns, and the new arrangement of ammo chutes eliminated the jam problem. Together with some other changes, the new P-51D was born at the end of 1943 and the production started at both Inglewood (serials with -NA suffix) and Dallas (-NT) plants. Due to the short supply of the Hamilton Standard alloy propellers used on Merlin powered P-51s, the Dallas Factory was fitting Aeroproduct ones with steel hollow blades to their Mustangs, these being marked P-51K.

The P-51D/K became the true ruler of the skies, serving as escort and patrol fighter, and also in ground attack or reconnaissance role (F-6 conversion). In total, 8,102 units of P-51D and 1,500 of P-51K were produced. The Mustang stayed operational after the War and served in pursuit and attack role even during the Korean War. The last P-51 retired from USAF service in 1978, while in foreign services it stayed operational until 1984 (Dominican Republic). Some 55 nations used the Mustang.

#### Ace maker and infinite warrior

The first Mustang aerial victory was achieved on August 19, 1942, when Flight Officer Hills shot down an Fw 190. It was the beginning of the incredible tally of 4,950 enemy aircraft shot down by Mustang pilots during World War II. Of them, 251 achieved the "ace" status. The most successful pilot of P-51 was George Preddy Jr., recording 24 of his 27 aerial victories flying Mustang, followed by John C. Meyer and John J. Woll with 21 kills each. Famous Charles Yeager, the first man to break the sonic barrier in 1947, was the first pilot of P-51D to become ace in just one day, after recording five kills on October 12, 1944.

#### The kit: P-51D-10

After longitudinal stability issues on the D-5 were solved with the addition of dorsal fin, the D-10 series was given its factory appearance, which differed slightly from the field modifications using the supplied kits. The sliding canopy received a modified opening handle and differently shaped canopies were also utilized. The D-10 series Mustangs kept the older N-9 reflex gunsight, but 8<sup>th</sup> AF were retrofitting their older Mustangs with more accurate gyro sight K-14 during 1944. Aircraft of this production block were also leaving the production lines with canvas rudders and elevators, but at the end of February 1945 the Technical Order T. O. 01-60-100 was issued, ordering all the canvas rudders to be changed for the all-metal ones.

ATTENTION



UPOZORNĚNÍ



ACHTUNG



ATTENTION



注意



Carefully read instruction sheet before assembling. When you use glue or paint, do not use near open flame and use in well ventilated room. Keep out of reach of small children. Children must not be allowed to suck any part, or pull vinyl bag over the head.



Před započítím stavby si pečlivě prostudujte stavební návod. Při používání barev a lepidel pracujte v dobře větrané místnosti. Lepidla ani barvy nepoužívejte v blízkosti otevřeného ohně. Model není určen malým dětem, mohlo by dojít k požití drobných dílů.

INSTRUCTION SIGNS

\* INSTR. SYMBOLS

\* INSTRUKTION SINNBILDEN

\* SYMBOLES

\* 記号の説明

OPTIONAL  
VOLBABEND  
OHNOUSAND  
BROUSITOPEN HOLE  
VYVRTAT OTVORSYMETRICAL ASSEMBLY  
SYMETRICKÁ MONTÁŽREMOVE  
ODŘÍZNOUTREVERSE SIDE  
OTOČITAPPLY EDUARD MASK  
AND PAINT  
POUŽIT EDUARD MASK  
NABARVIT

PARTS



DÍLY



TEILE



PIÈCES



部品の

## PLASTIC PARTS

A&gt;

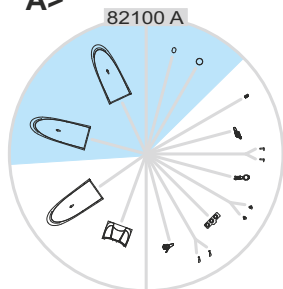

B&gt;

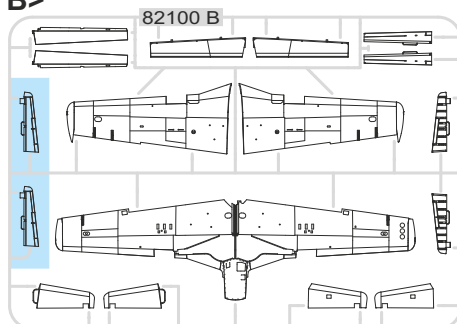

D&gt;

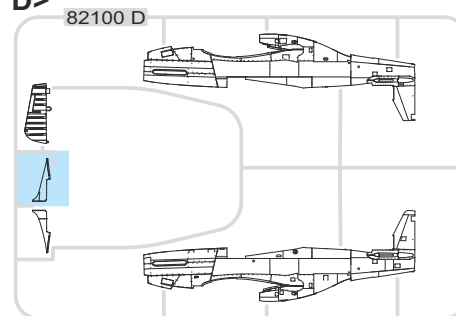

F&gt;

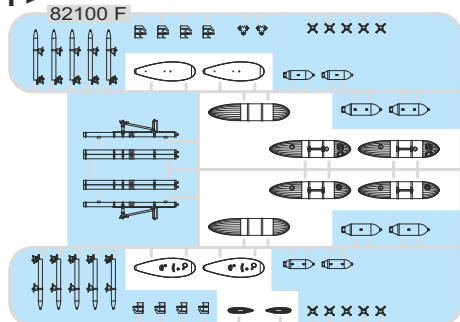

G&gt;

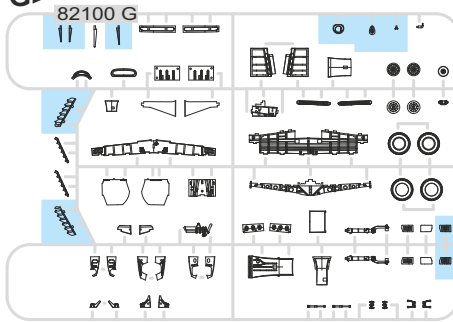

H&gt;

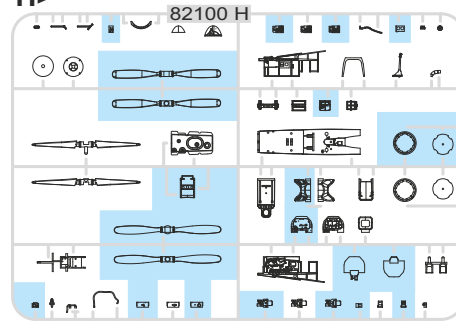

-Parts not for use. -Teile werden nicht verwendet. -Pièces à ne pas utiliser. -Tyto díly nepoužívejte při stavbě. -

COLOURS



BARVY



FARBEN



PEINTURE



色

GSI Creos (GUNZE)		MISSION MODELS	
AQUEOUS	Mr.COLOR	PAINTS	
H1	C1	MMP-001	WHITE
H6	C6	MMP-004	GREEN
H8	C8		SILVER
H11	C62	MMP-001	FLAT WHITE
H12	C33	MMP-047	FLAT BLACK
H15	C65		BRIGHT BLUE
H27	C44		TAN
H37	C43		WOOD BROWN
H47	C41	MMP-012	RED BROWN
H52	C12	MMP-091	OLIVE DRAB
H53	C13		NEUTRAAL GRAY
H58	C351	MMP-059	INTERIOR GREEN
H77	C137	MMP-040	TIRE BLACK
H90	C47		CLEAR RED
H91	C48		CLEAR YELLOW

GSI Creos (GUNZE)			MISSION MODELS	
AQUEOUS	Mr.COLOR	PAINTS		
H94	C138		CLEAR GREEN	
H327	C327	MMP-101	RED	
H328	C328		BLUE	
H329	C329	MMP-041	YELLOW	
H330	C361	MMP-077	DARK GREEN	
H335	C363	MMP-094	MEDIUM SEAGRAY	
	C352		YELLOW CHROMATE	
Mr.METAL COLOR			METALLICS	
MC214			MMM-001	DARK IRON
Mr.COLOR SUPER METALLIC			METALLICS	
SM201			MMC-001	SUPER FINE SILVER
SM203				SUPER IRON
SM206			MMC-001	SUPER CHROME SILVER

**A**

**1** = 90% + 10%  
[H58 MMP C351 059] [H12 MMP C33 047]  
INTERIOR GREEN FLAT BLACK

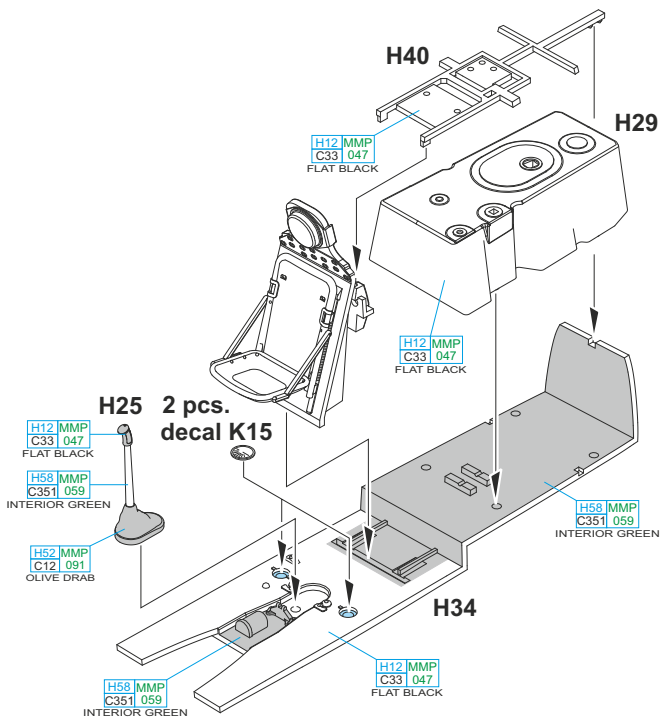
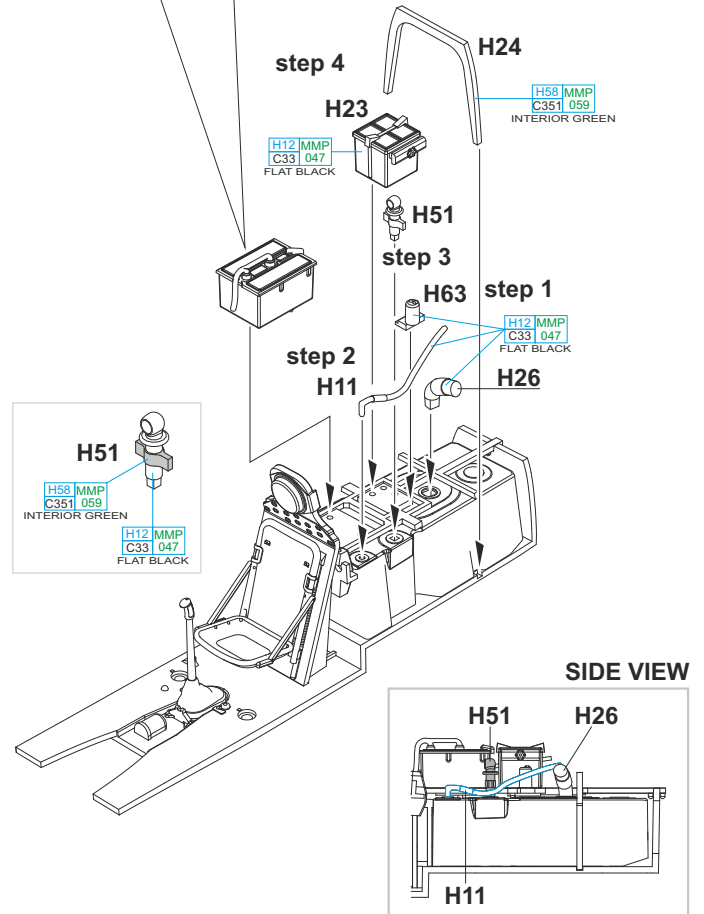
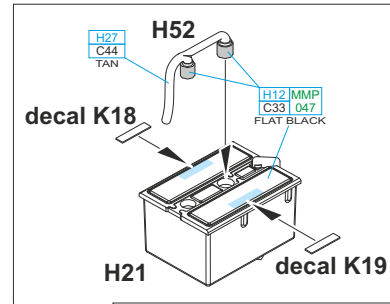
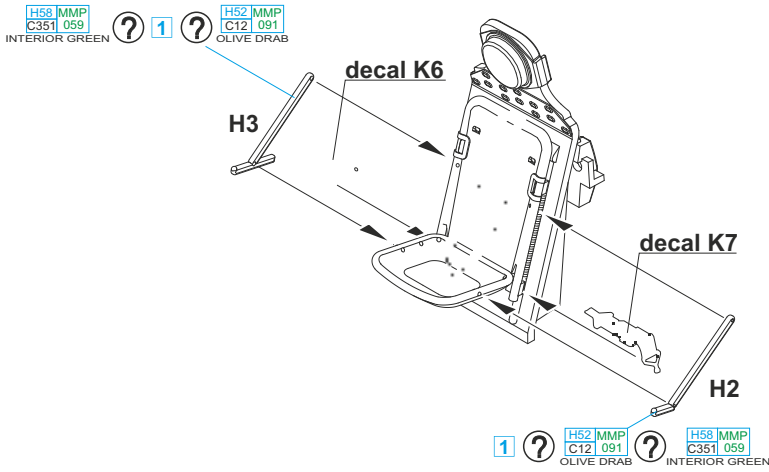
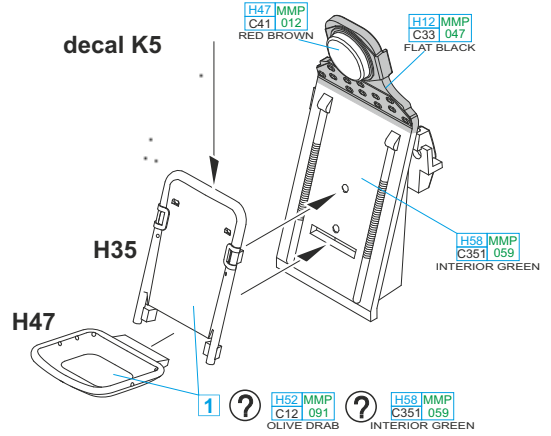
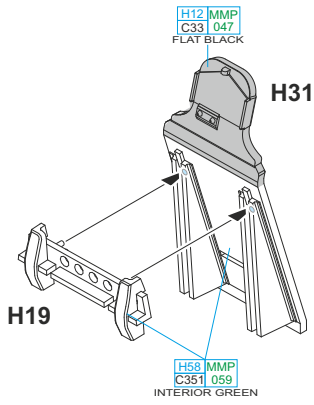





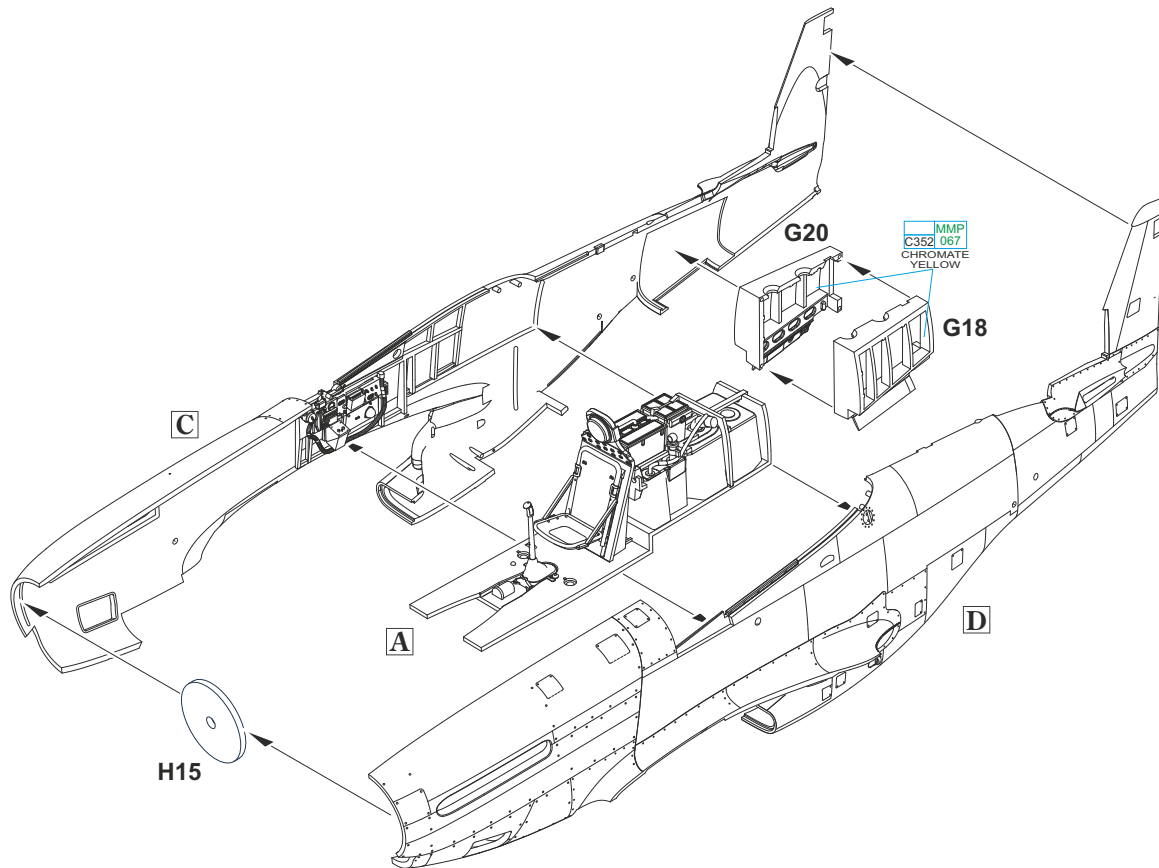

**E**

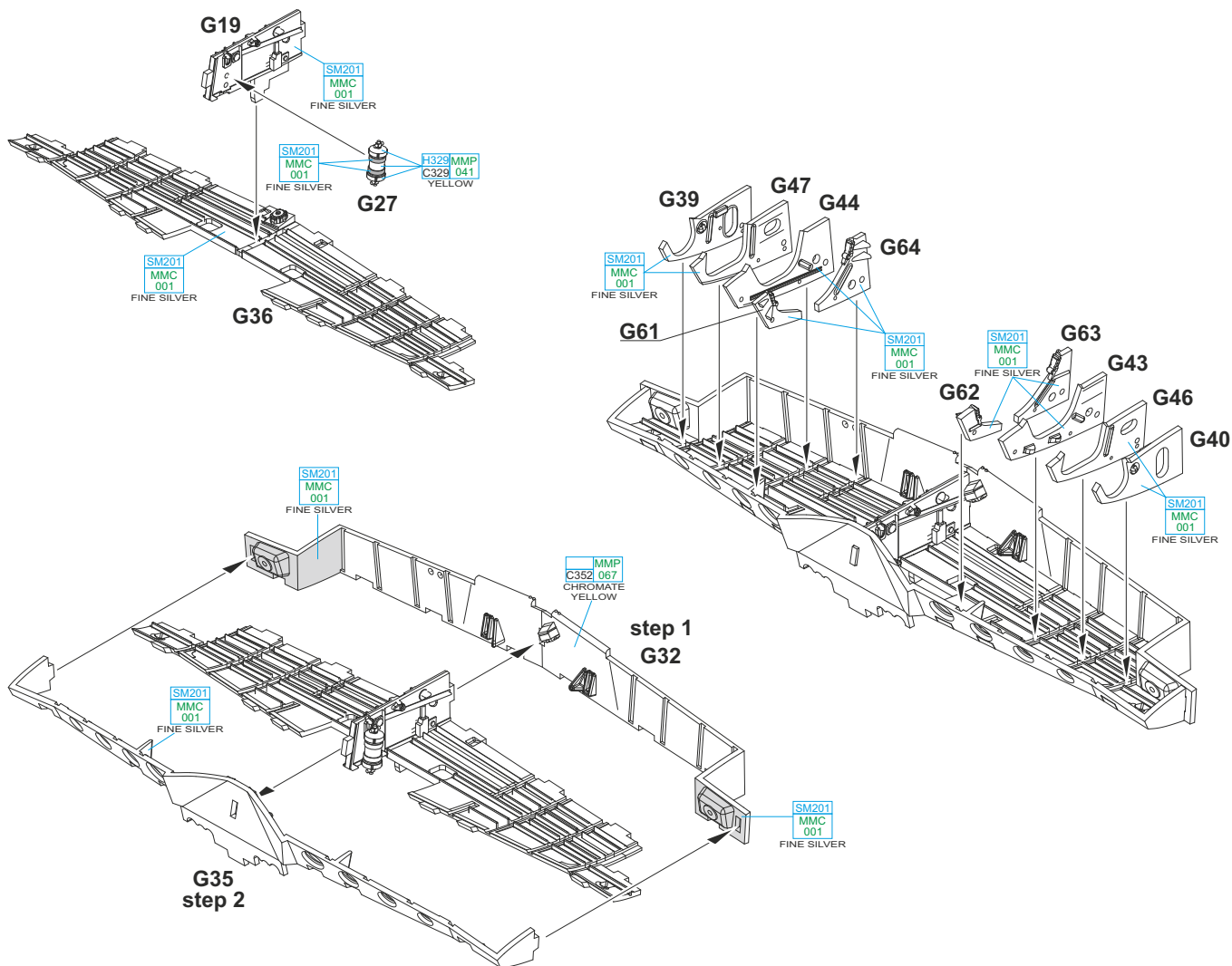



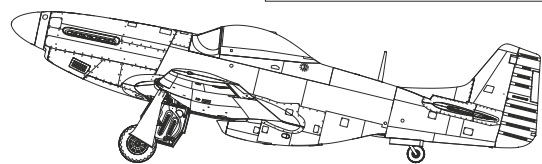
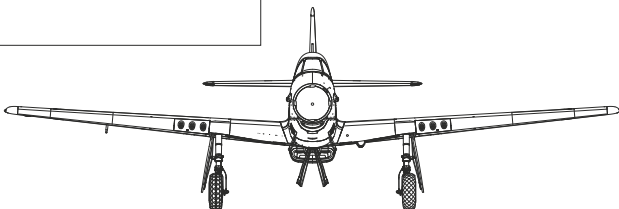
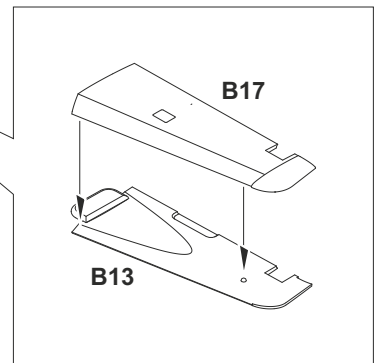
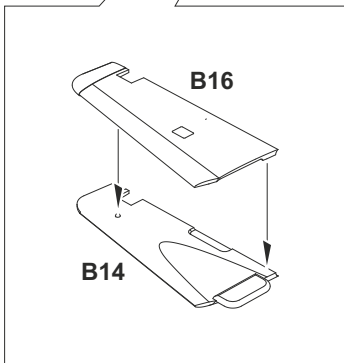
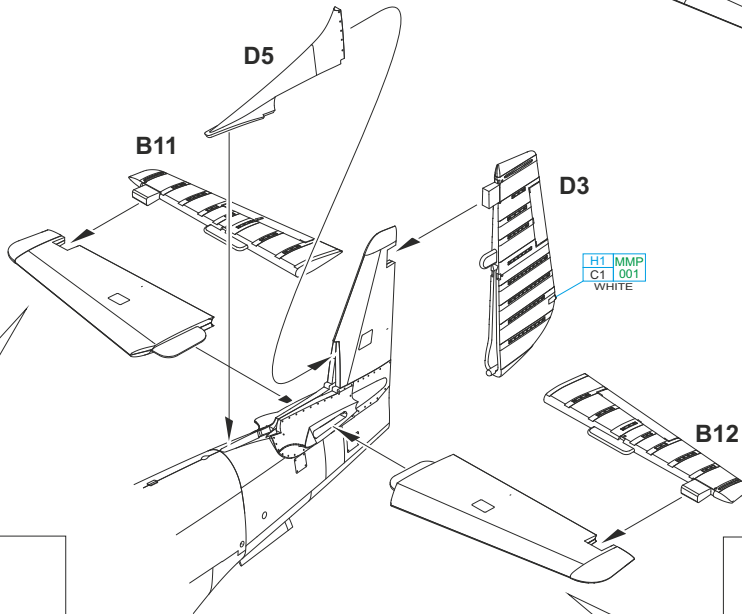
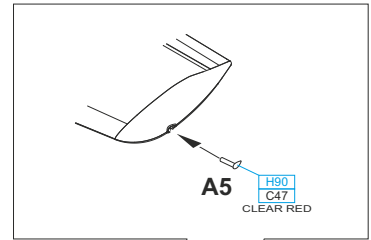
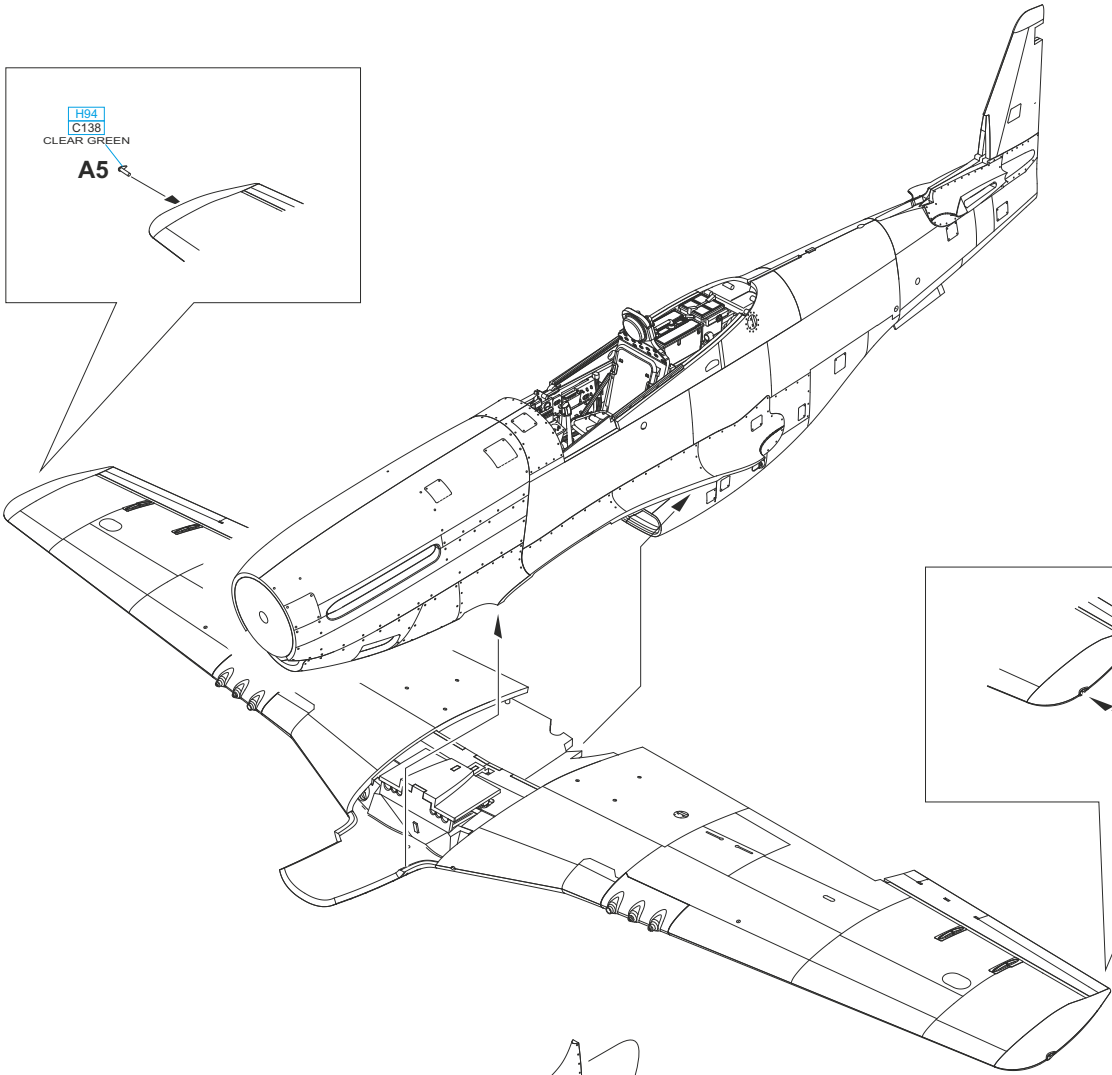
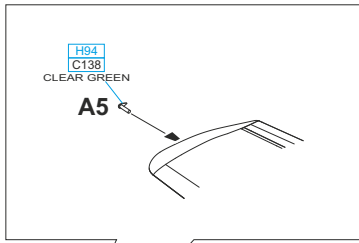

**OPTIONAL:**  
decal K1, K2, K8, K9, K10

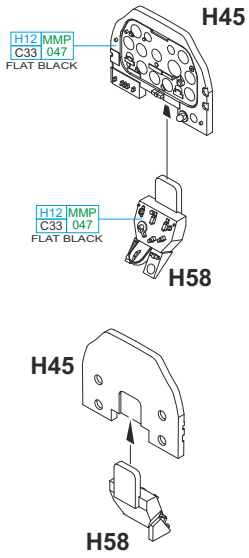

A3,A4 - MARKINGS **A, B, C**  
A11 - MARKING **D**

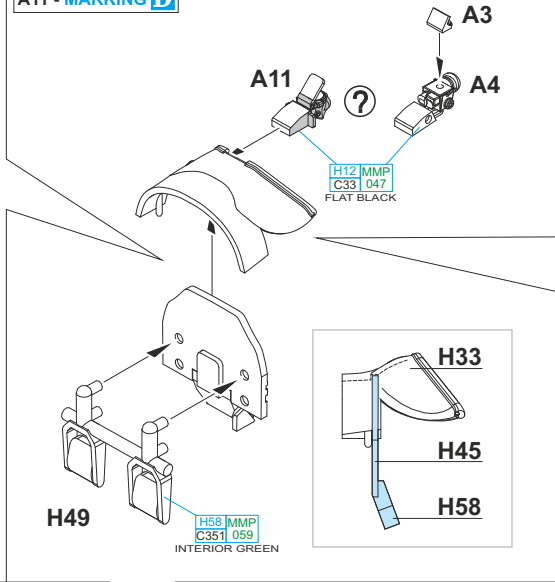

A8 right → A7 left

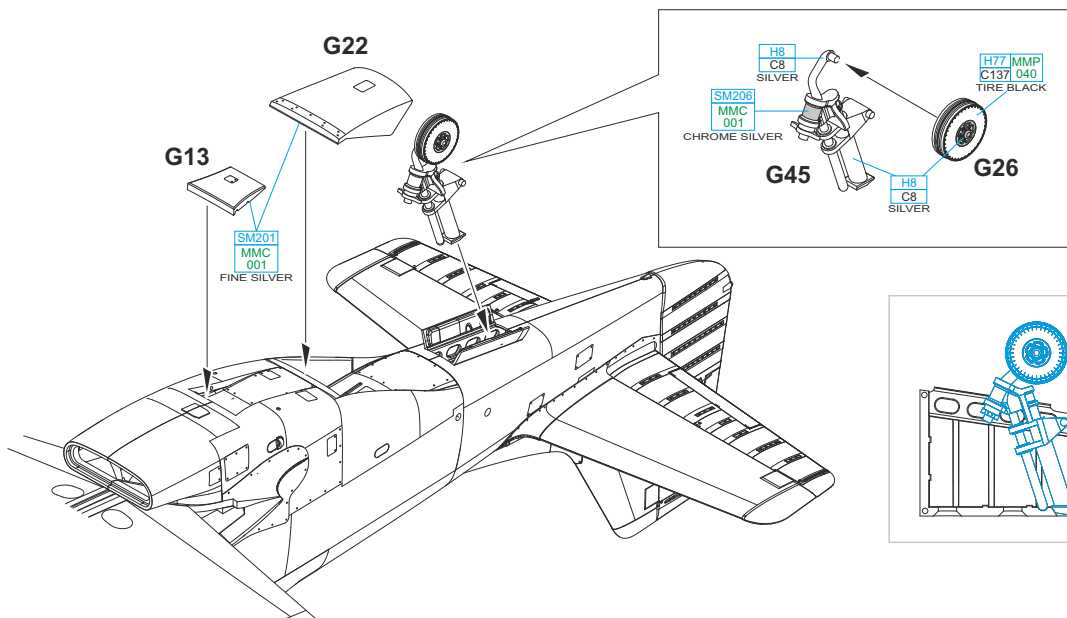
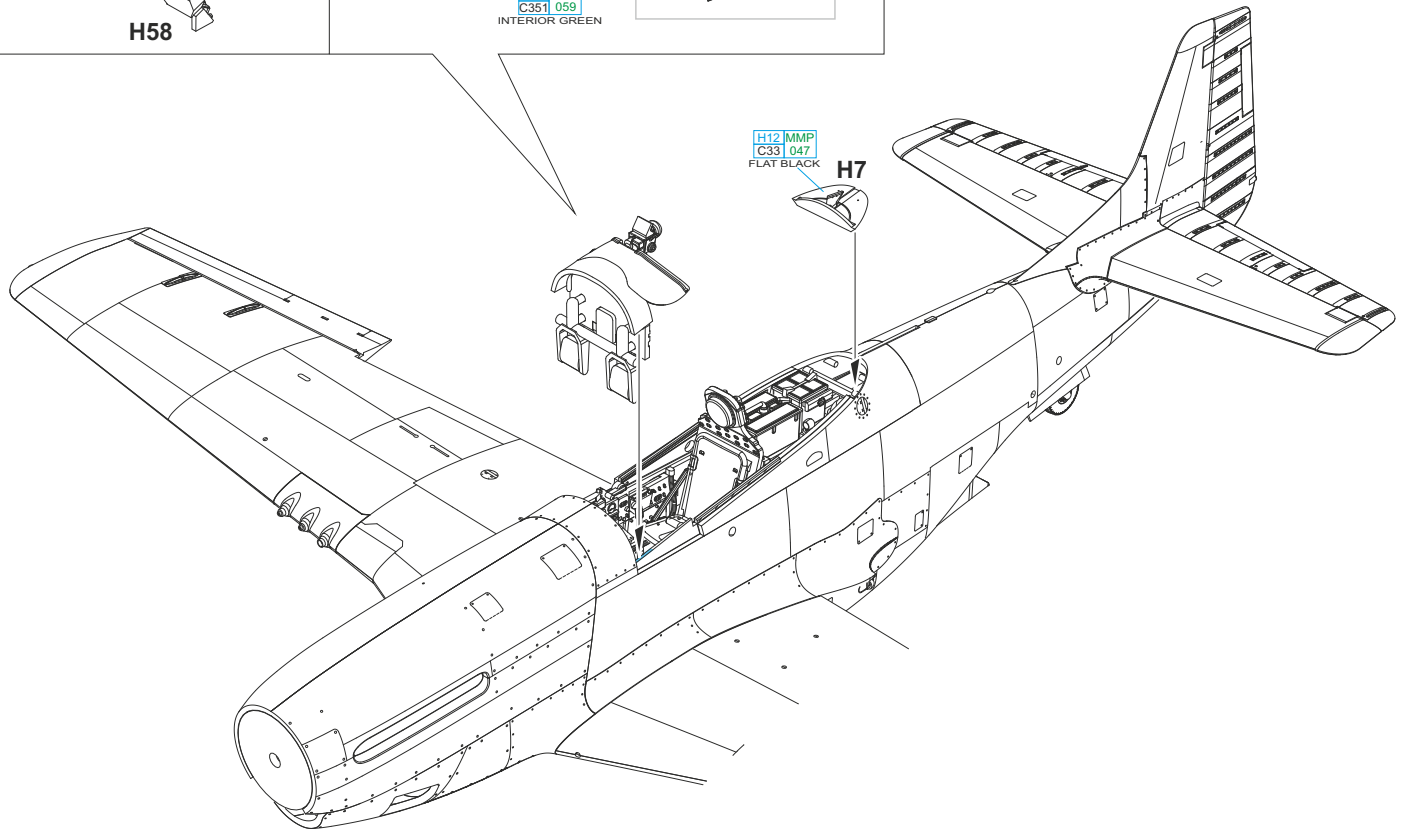
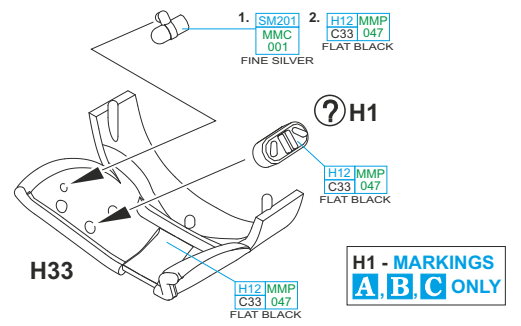



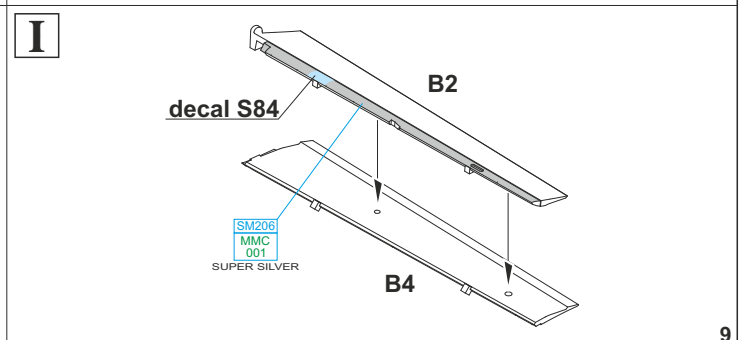
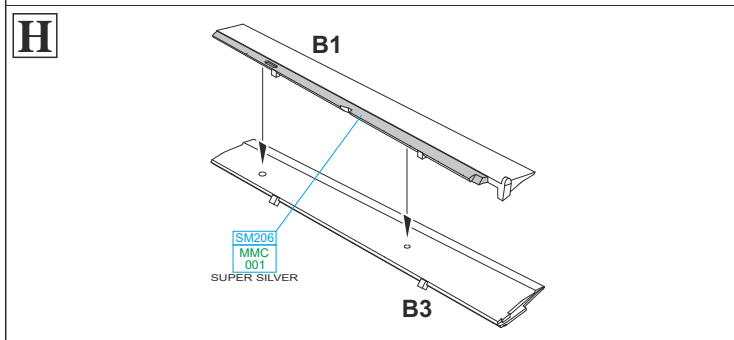
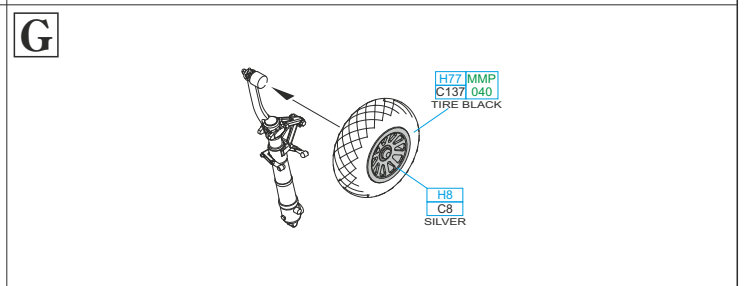
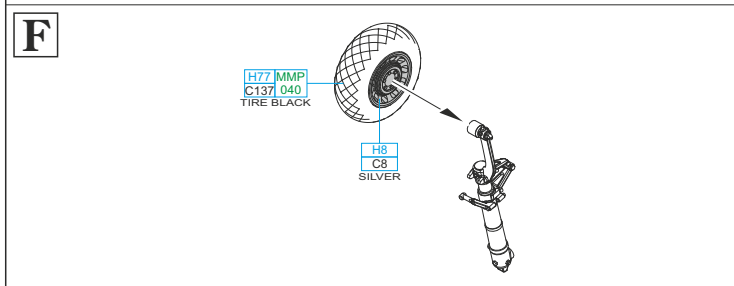
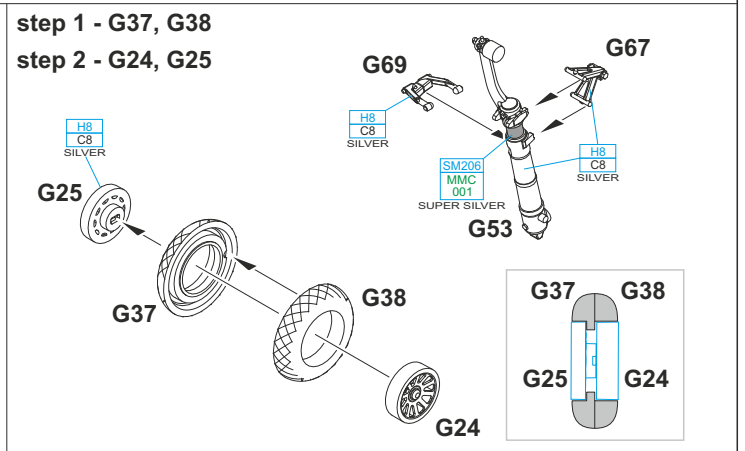
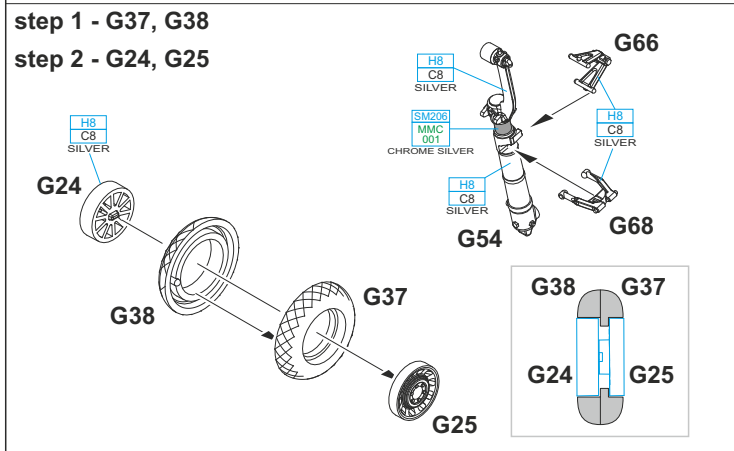
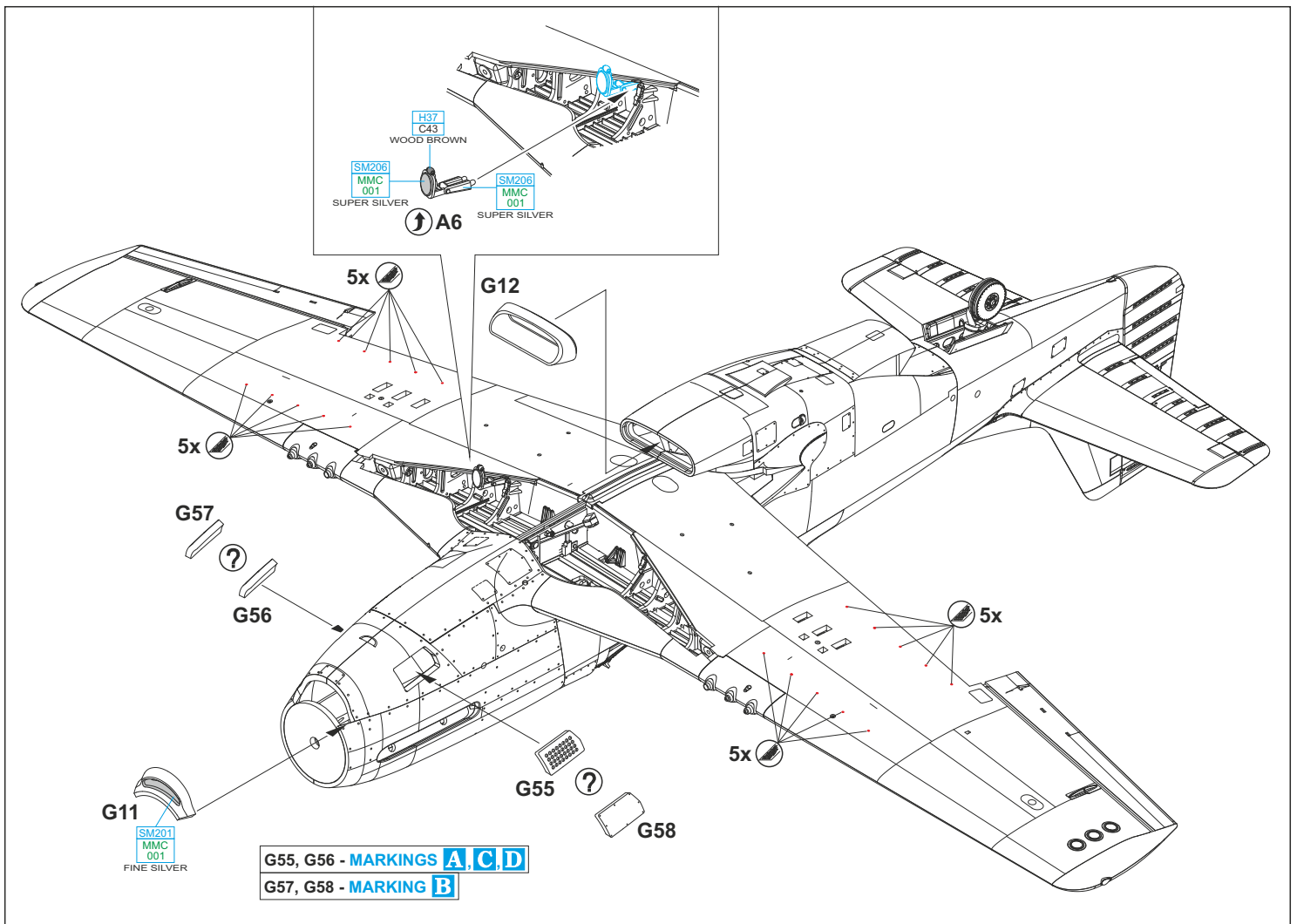

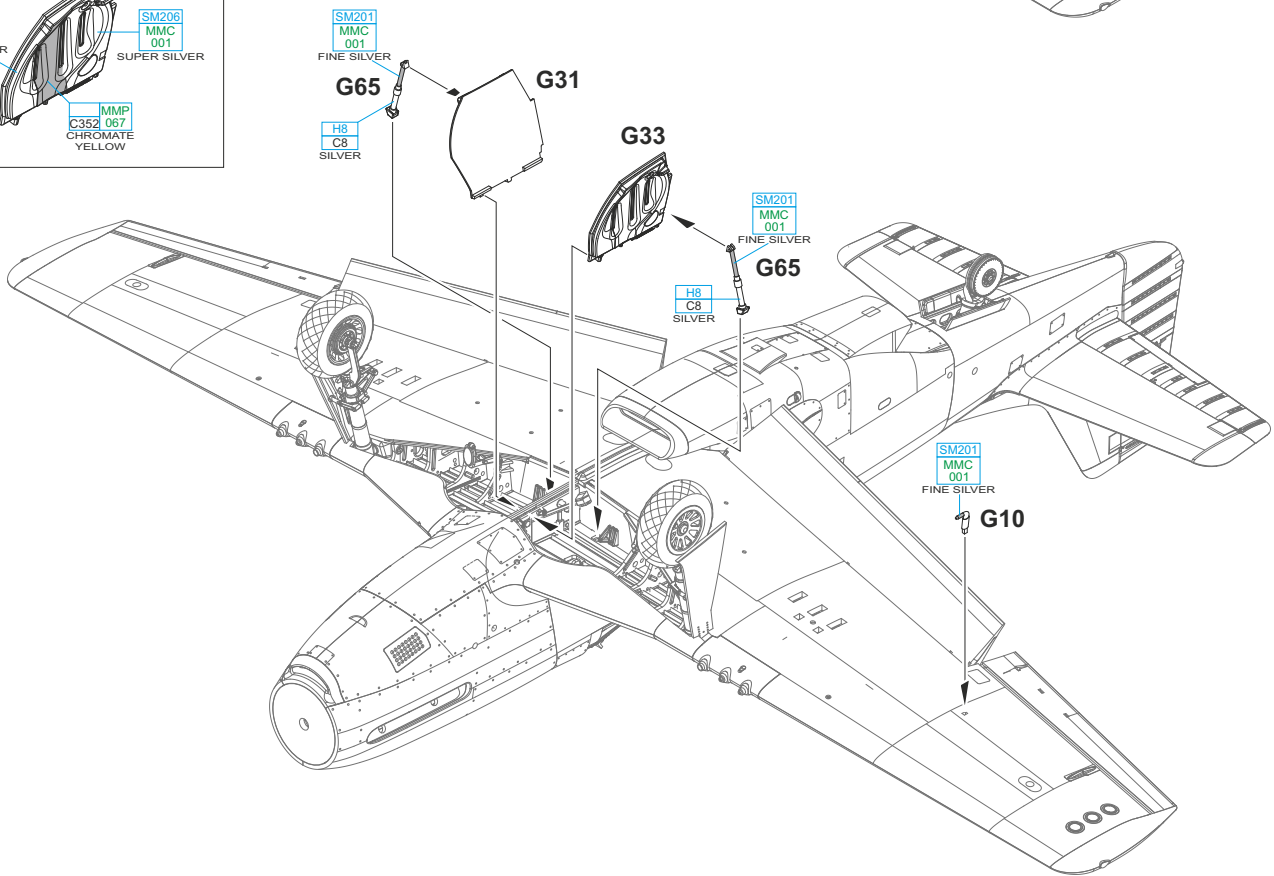
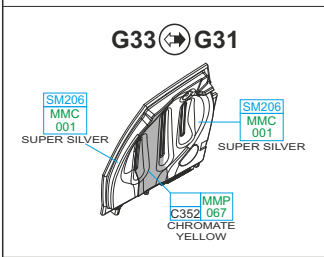
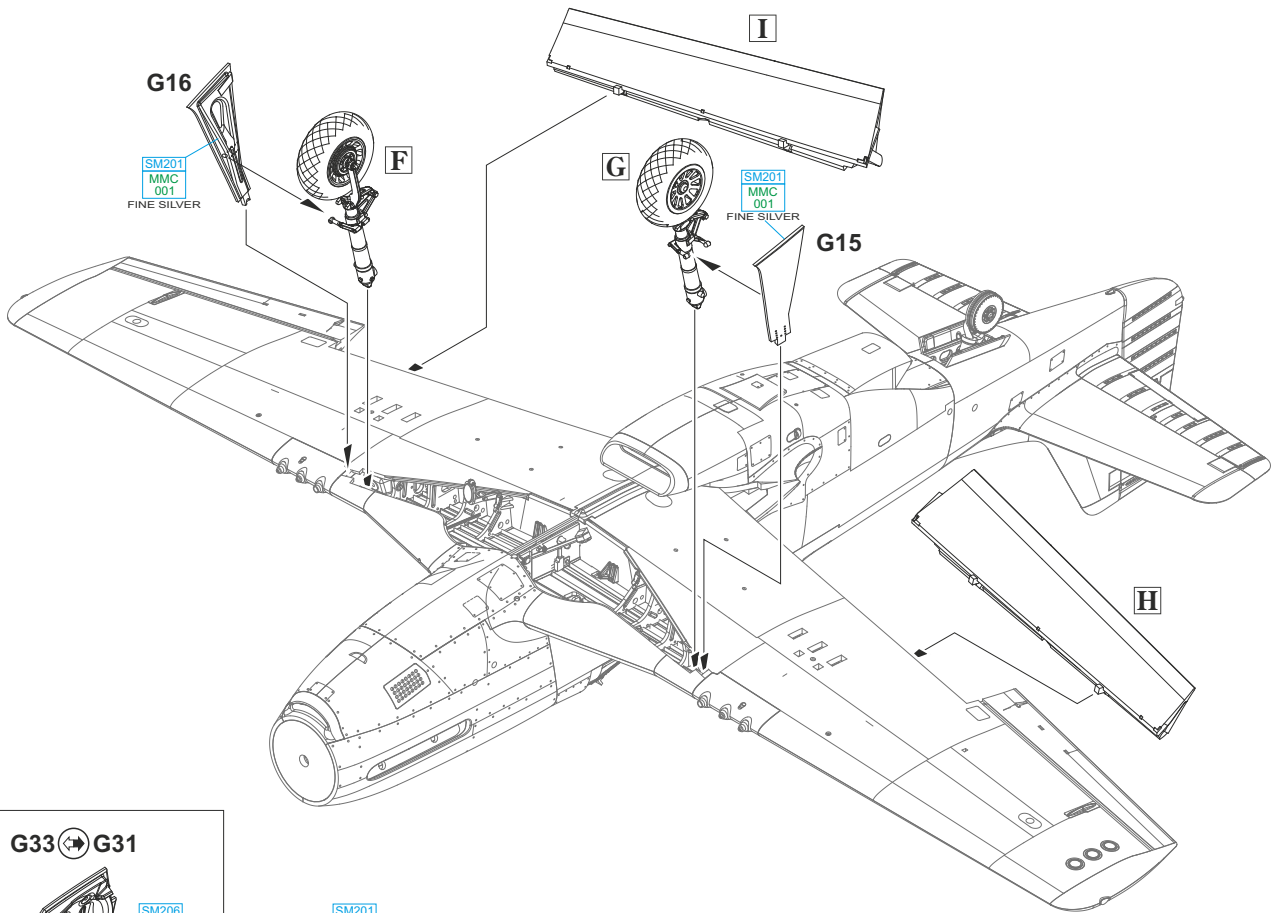

**J**



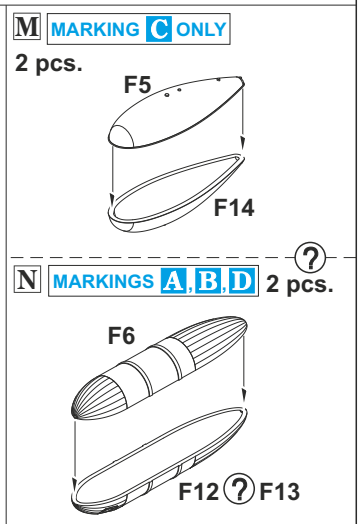
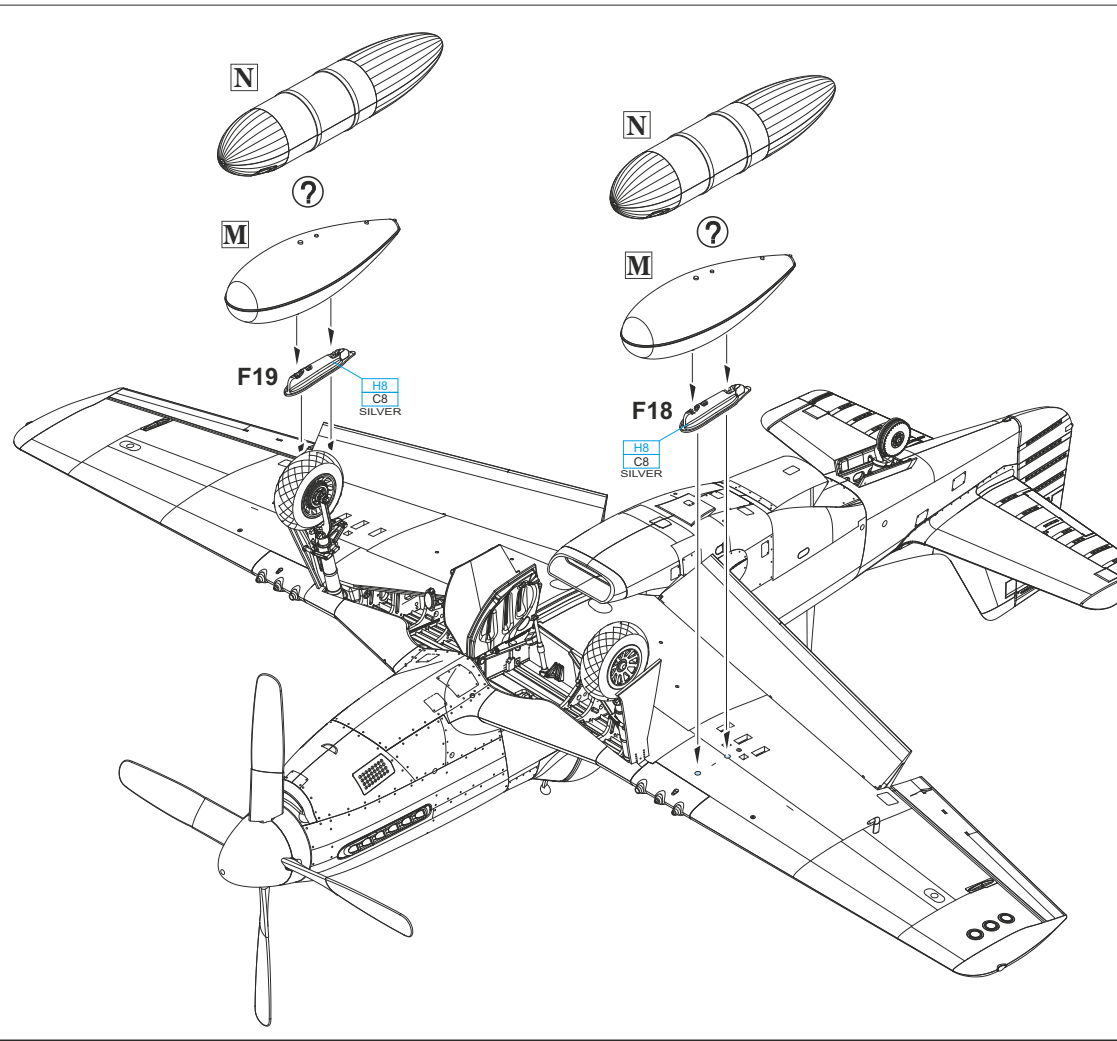
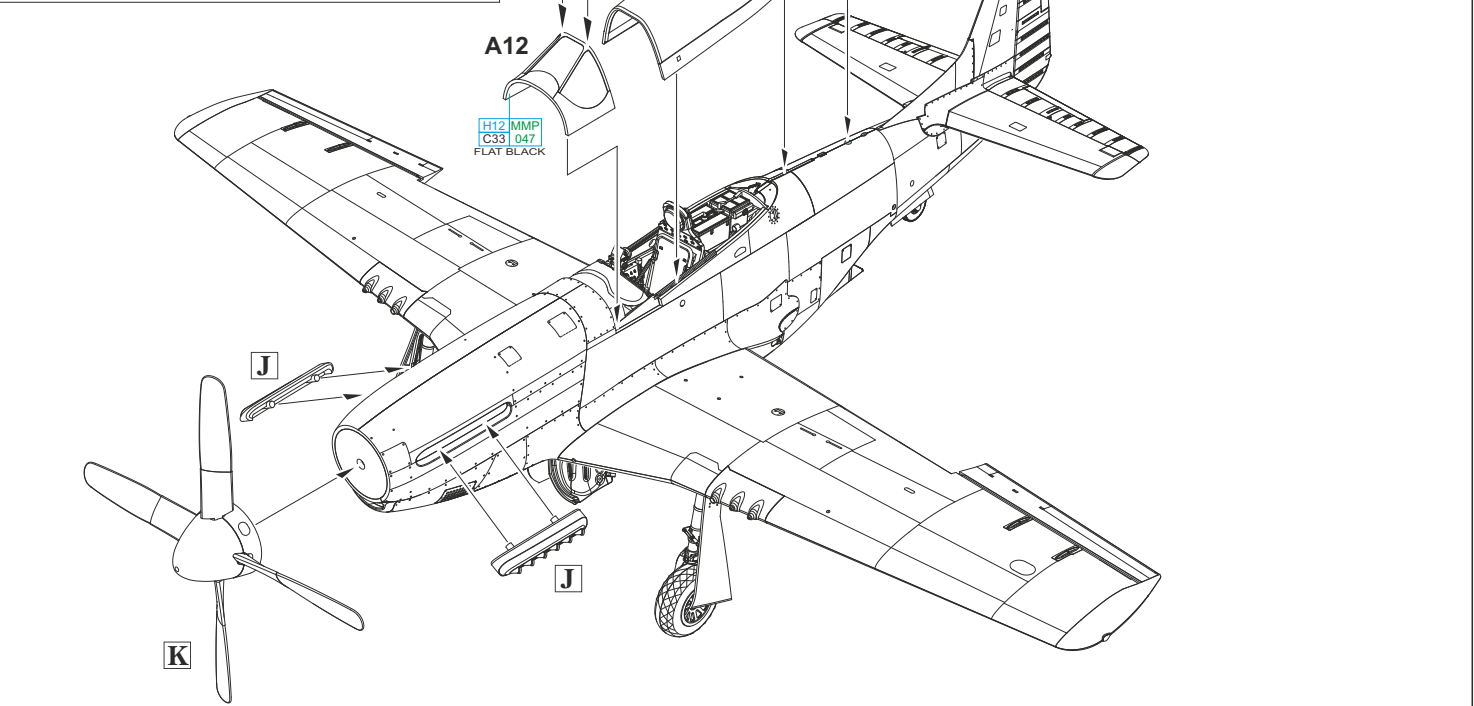
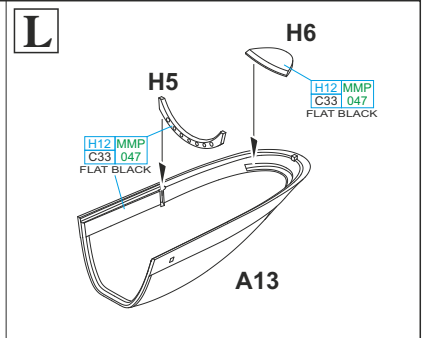
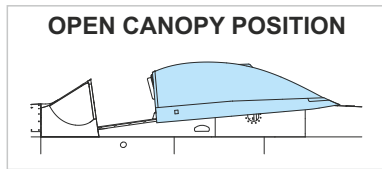
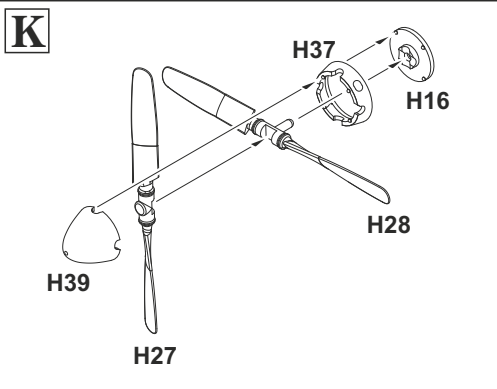

**A** s/n 44-14223, Lt. Col. Elwyn G. Righetti, CO of 55<sup>th</sup> FG, 8<sup>th</sup> AF, Wormingford, United Kingdom, December 1944–March 1945

Elwyn Guido Righetti, also known as "Eager El", was not only the 55<sup>th</sup> FG top fighter ace but also the most successful strafing ace in the whole ETO. Righetti joined the 338<sup>th</sup> FS, 55<sup>th</sup> FG in October 1944. At the age of 29, he was already a matured pilot, however he lacked the combat experience. Despite his age he was eager and aggressive, so he was able to boost morale of his rather tired group. One of Righetti's "hobbies" was destroying the locomotives. He also managed to shoot down two Mistels and destroyed several Me 262 jets on the ground. Unfortunately, Righetti's outstanding achievements were cut short right before the end of war. On April 17, 1945, exactly on his 30<sup>th</sup> birthday, Righetti was shot down by flak while raiding the airfield near Dresden. He successfully performed the emergency landing and advised his friends over the radio "Tell the family I'm okay. Broke my nose on landing. It's been a hell of a lot of fun working with you, gang. Be seeing you a little later." Since then no one ever heard about Righetti again. Supposedly he was murdered by the enraged German civilians. During his short combat career, he scored 7.5 kills and destroyed 35 enemy aircraft on the ground. He flew two personal Mustangs (44-14223 and 44-47222), both of them were decorated with the inscription KATYDID and grasshopper artwork on the port side of the fuselage.

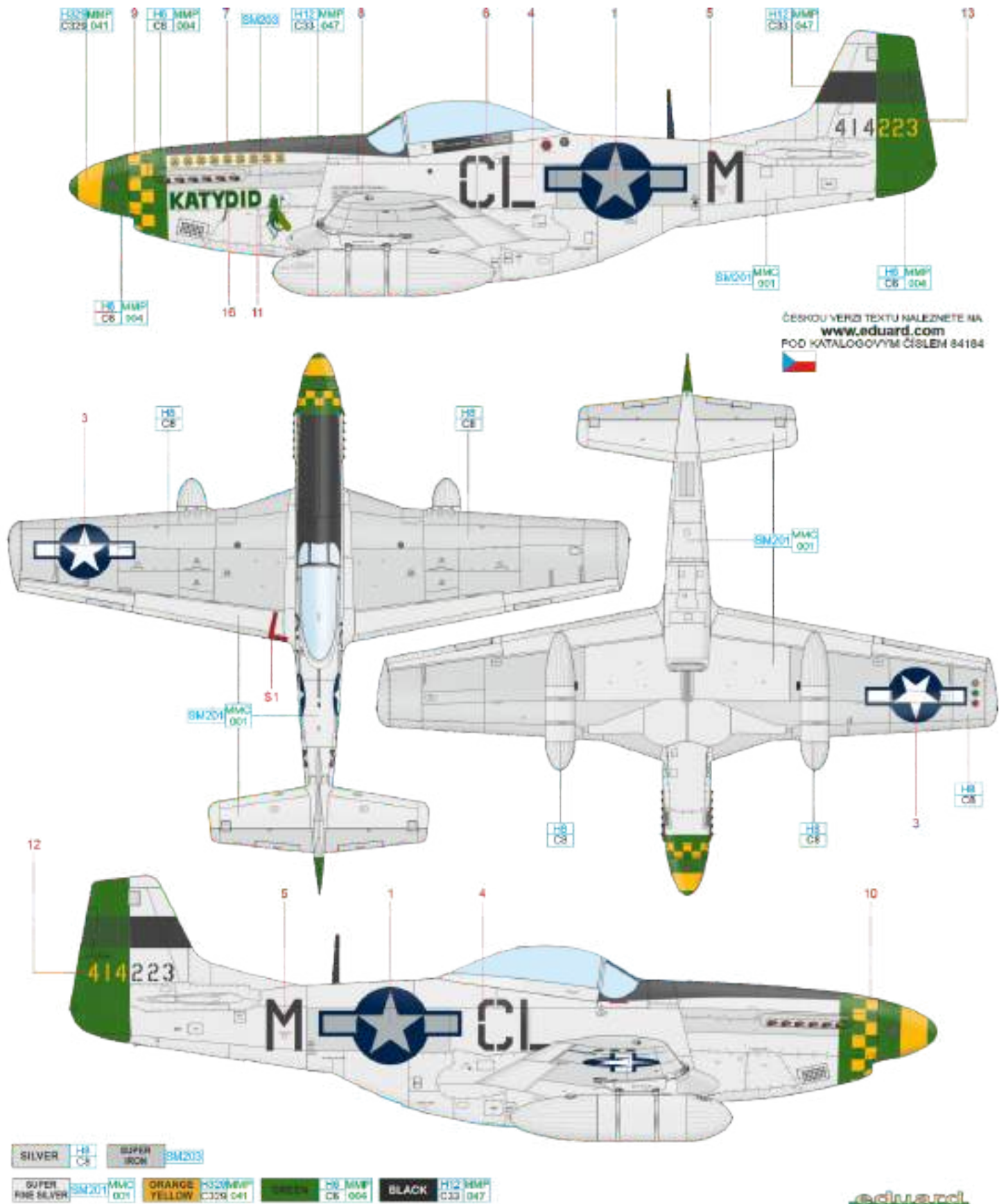



Clairborne Holmes Kinnard was one of the most successful pilots in the combat against the ground targets. He was born on October 29, 1912, in Franklin, Tennessee. After he obtained his pilot's certification in 1944, he led the 354<sup>th</sup> FS from November 27 until June. On June 12, 1944, he assumed command of the 355<sup>th</sup> FG which he led until the end of August. In September he was ordered to 4<sup>th</sup> FG which he also briefly commanded from November 3 until November 29, 1944. Then he returned to 355<sup>th</sup> FG where he flew until May 1945. During his combat career he scored eight aerial kills and destroyed further seventeen enemy aircraft on the ground. Kinnard flew the depicted, unusually painted Mustang from October to November 1944 as a commander of the 4<sup>th</sup> FG. His aircraft was decorated with the inscription Man O'War painted red on the nose's port side and the upper surfaces were painted with green camouflage bands, possibly in the Olive Drab shade. The kill marking were painted on the port side of the canopy frame. The invasion stripes appearance corresponds to the modification after the beginning of September 1944 when only the part of the markings remained at the bottom of the fuselage. From November 3 till November 29, 1944, Kinnard commanded the 4<sup>th</sup> FG, then he returned to the 355<sup>th</sup> FG where he served until May 1945.

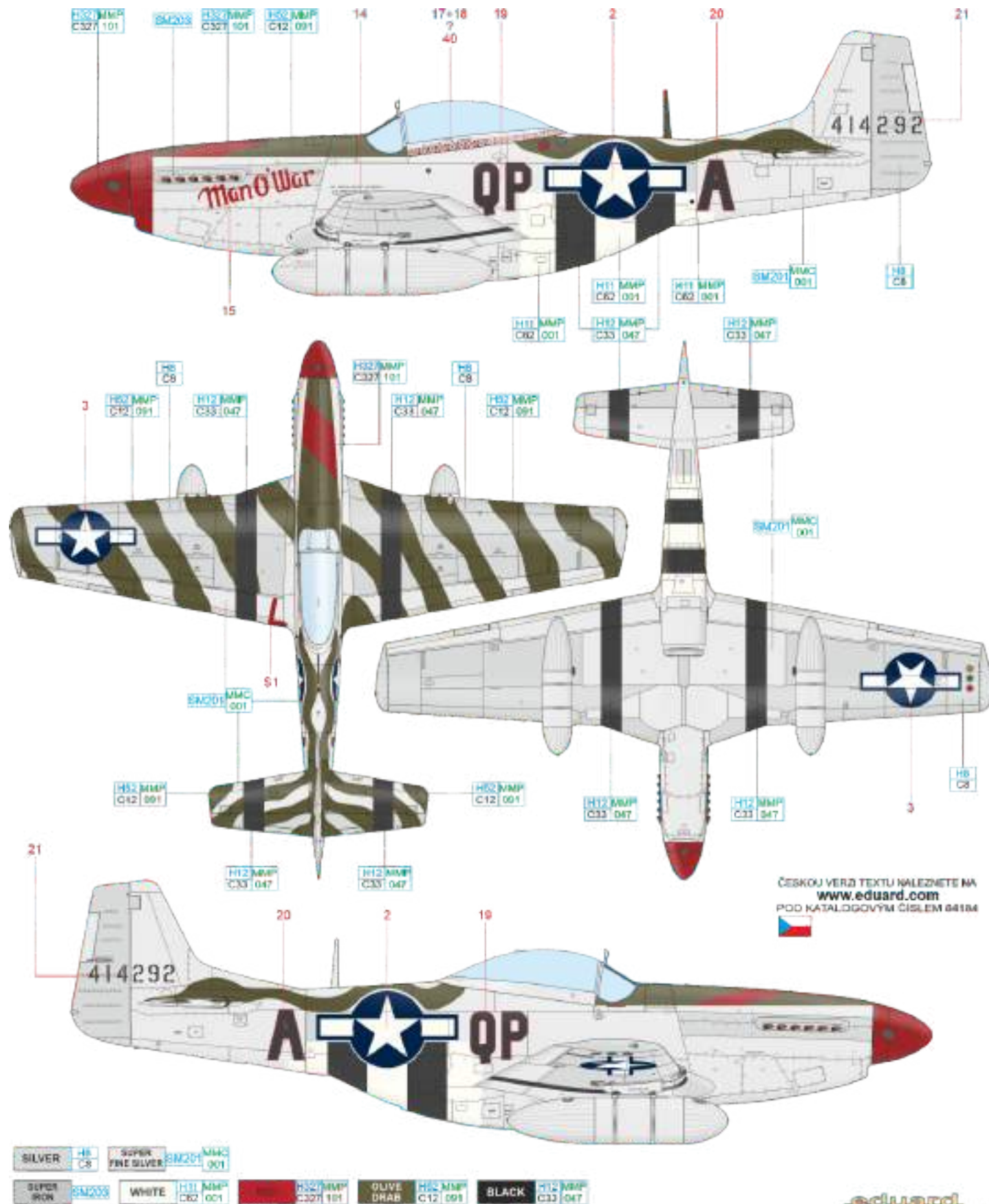





# D s/n 44-14789, Capt. John B. England, 362<sup>nd</sup> FS, 357<sup>th</sup> FG, 8<sup>th</sup> AF, Leiston, United Kingdom, December 1944

John Brooke England was born on January 15, 1923, in Caruthersville, Missouri. In April 1942 he enlisted in the Army Volunteer Reserves and after completing the pilot training in March 1943 he was assigned to the 362<sup>nd</sup> FS whose command he assumed on August 25, 1944. He served two tours of duty with 357<sup>th</sup> FG during which time he flew 108 combat missions representing 460 hours of the operational flying. He was the second best marksman of the 357<sup>th</sup> FG scoring in total 17.5 kills. In the end of January 1945 England finished his second tour of duty and returned home. After the war he continued serving with USAAF. On February 20, 1951, he was promoted to Lieutenant Colonel and briefly served in Korea where he flew in total six combat missions during which he managed to damage MiG-15. In October 1953 he assumed command of the 389<sup>th</sup> FBS. On November 17, 1954, he was killed during the accident at the Toul airport (France) when under the inclement weather and low visibility he tried several times to land his F-86F. During the last approach he ran out of fuel but regardless he avoided the airbase building. Thanks to his sacrifice the Alexandria airbase was renamed to the England Air Force Base.

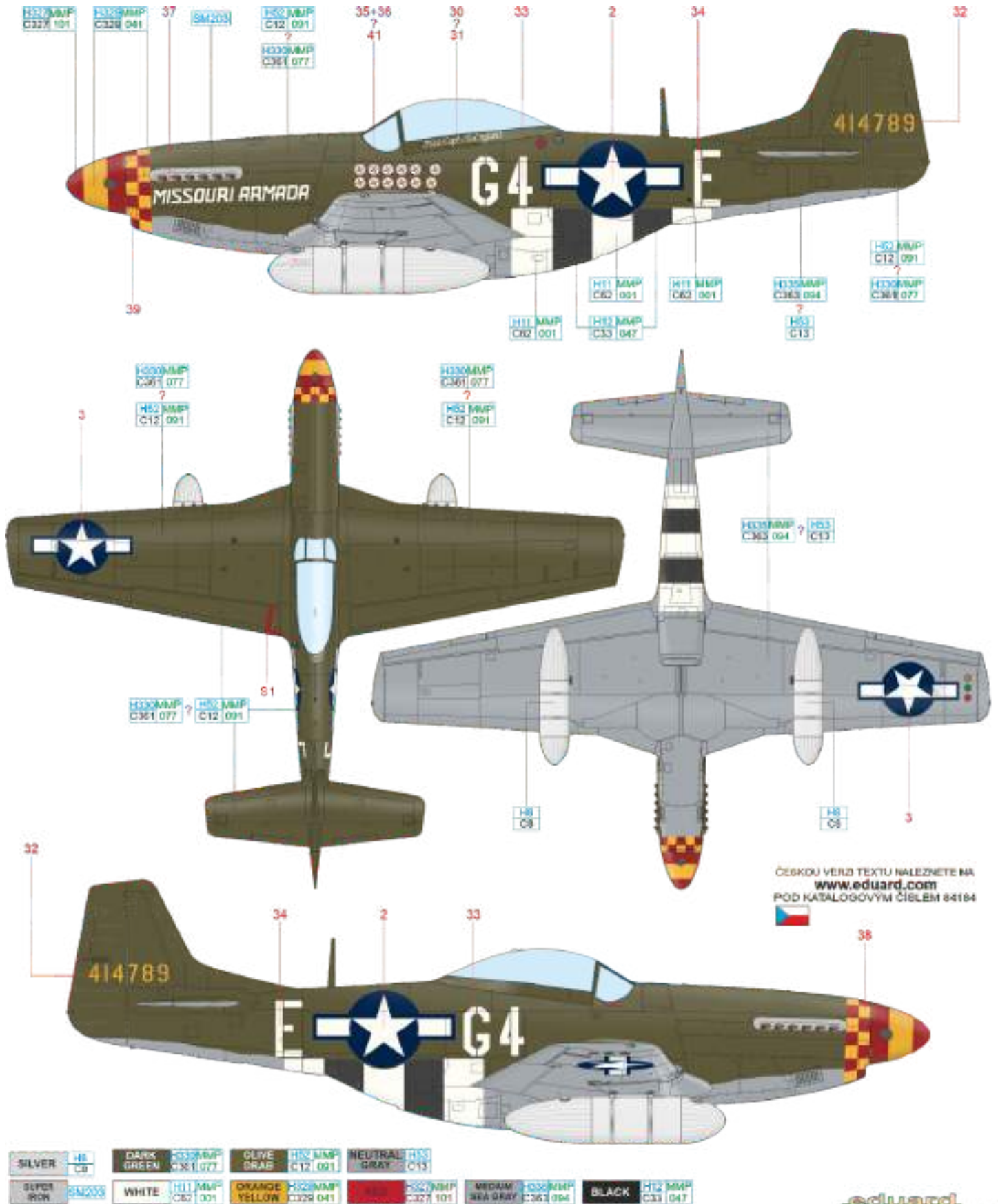

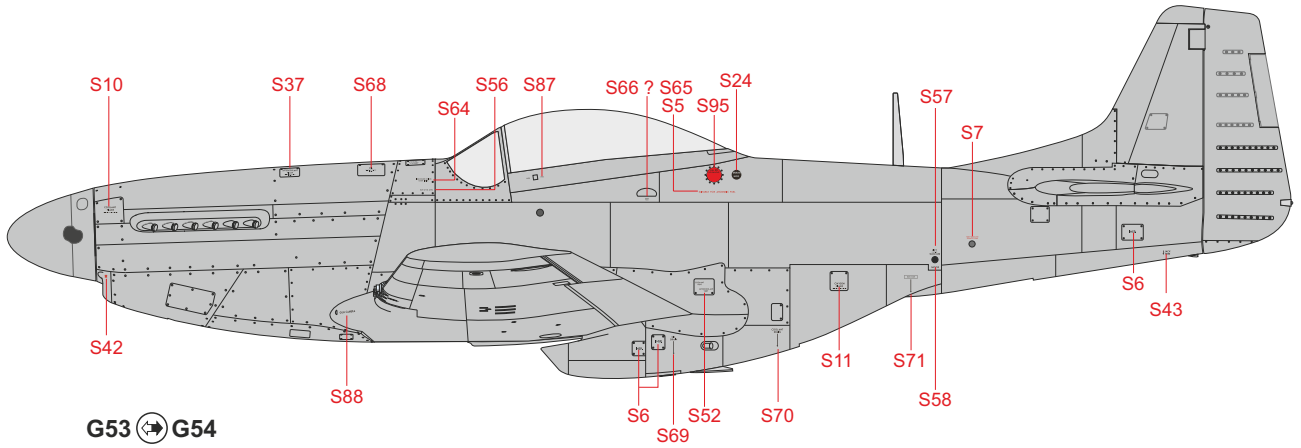

G53 G54

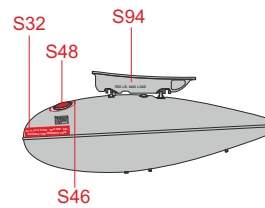
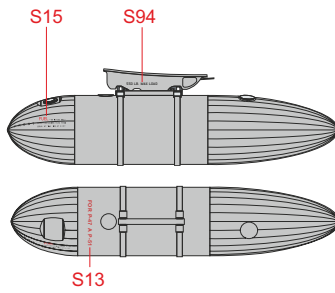
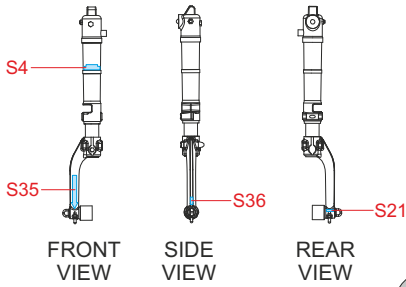

Parts No. H27, H28

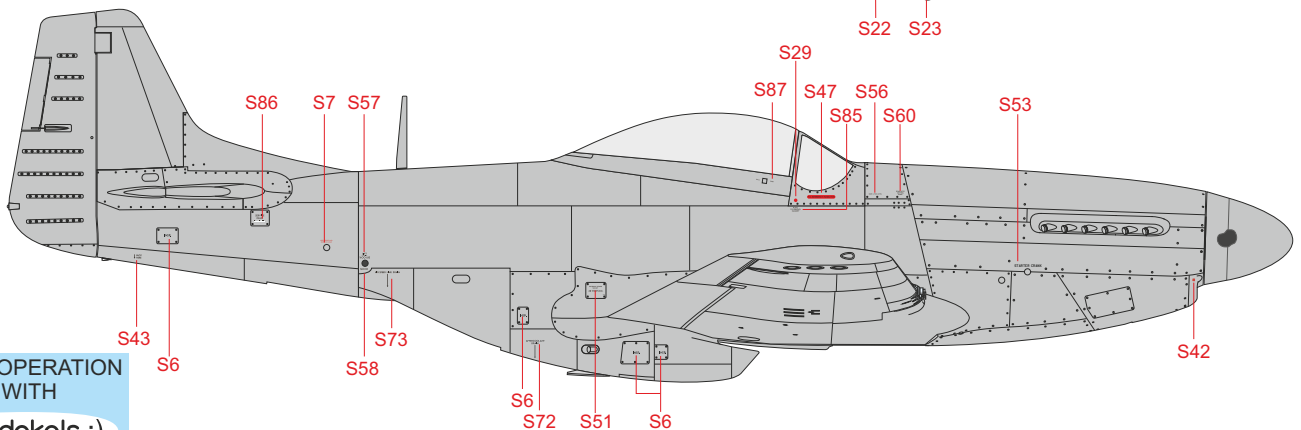
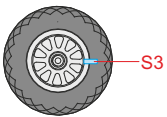
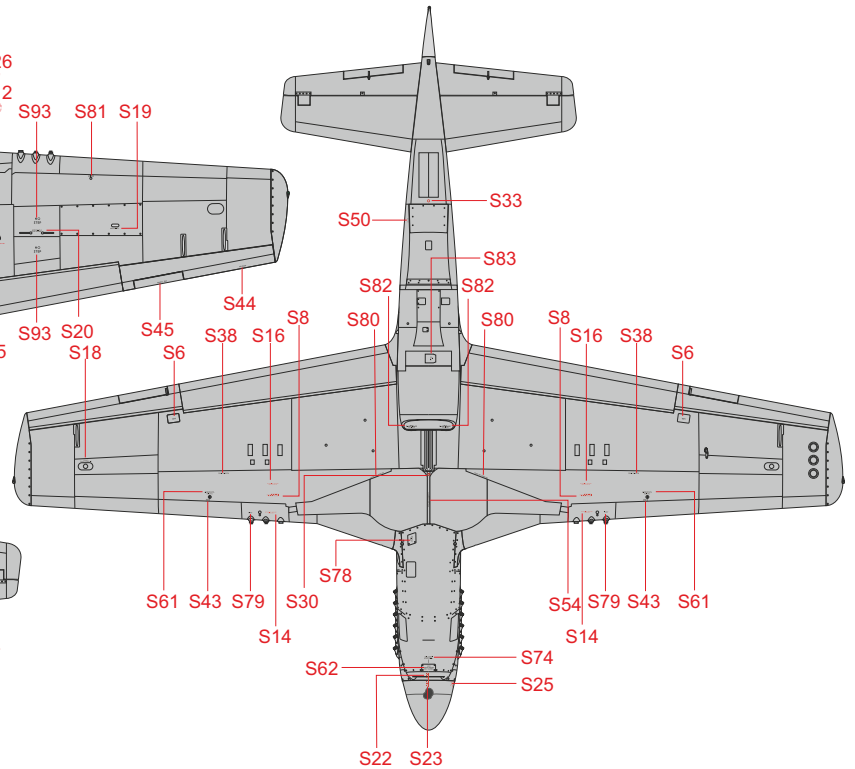
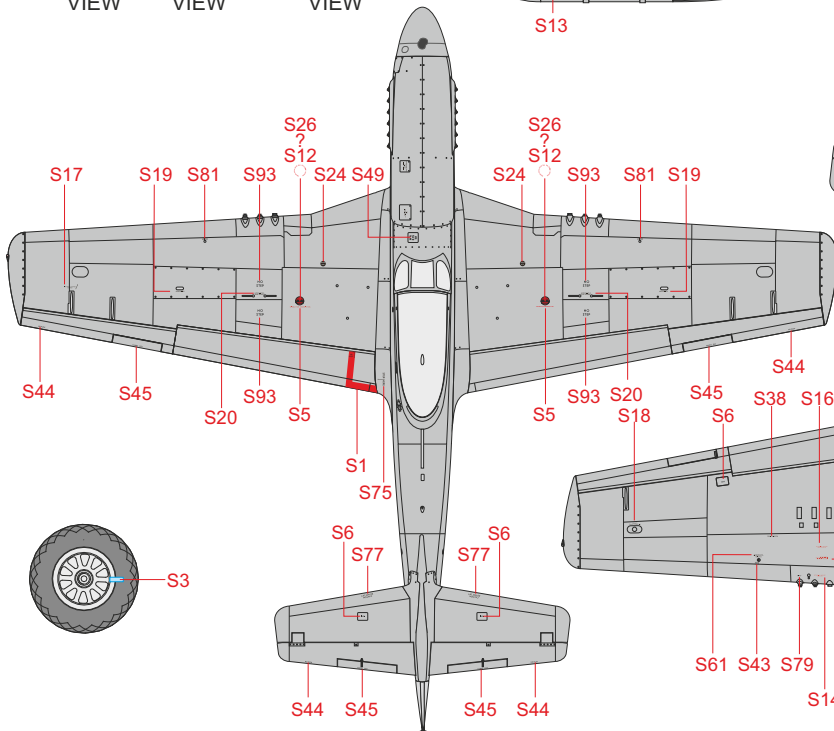
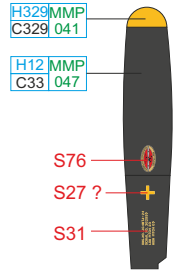

IN COOPERATION WITH  
fündekals :)