



DUAL COMBO!



intro

The Royal Aircraft Factory SE.5a is credited with being one of the fastest and deadliest aircraft of World War I. But the story of this 'Spitfire of Great War', as it is sometimes referred to, is not so straightforward. The SE. 5 (Scout Experimental 5) was designed by Henry Folland, John Kenworthy and Frank Goodden as a fighter powered by the new 150hp V8 Hispano-Suiza 8Aa engine. As the rotary engines neared their limitations, in-line liquid cooled engines were supposed to be a more promising way to fly faster and higher. The first prototype of the new fighter made its maiden flight on November 22nd, 1916 and began a somewhat intricate journey from miserable testing to combat proven glory. The new engine was troublesome and the wing design of the plane had glitches. The first two prototypes were lost in crashes, with chief test pilot at the Royal Aircraft Factory and one of the aircraft's designers, Major F. W. Goodden, losing his life on January 28th, 1917. The problems were partly solved thanks to modifications adopted on the third prototype, thus creating the first production variant of the new fighter.

The SE.5 entered service with No.56 Sqn RFC, during April 1917. The squadron was home to several famous aces. One of them, Albert Ball, was instrumental in honing the SE.5 into a formidable airplane. The new fighter was received with mixed emotions because of its unusually high seat position, large windscreen and armament layout that was composed of fuselage mounted 0.303 Vickers and upper wing mounted 0.303 Lewis machine guns. Ball, together with his mechanic, worked during the nights to address smaller as well as bigger glitches of the new design and most of the changes they made to the design were adopted for all SE.5s at squadron level. The large windscreen was dispensed with and the pilots lowered their seats to a more normal position. But, they always prayed for good visibility from the cockpit. The changes made by No.56 Sqn were shortly adopted for production. The final few SE.5 aircraft built in July 1917 were fitted with a more powerful 200hp Hispano-Suiza 8Ab engine, effectively setting the SE.5a standard. Production of the SE.5 ended after only 77 examples being built. The SE.5a was then produced in high quantities by six manufacturers: Vickers (2164), Austin Motors (1650), Air Navigation and Engineering Company (560), Wolseley Motors Limited (431), Martinside (258) and Royal Aircraft Factory (200). The American Curtiss Aeroplane and Motor Company built one example, as production of some 1000 aircraft was considered there. The US Army Squadrons of the American Expeditionary Force were among those receiving the SE.5a, and the Curtiss supplies would equip them. But the armistice ended this plan.

The SE.5a is frequently compared to another famous WWI fighter, the Sopwith Camel, the last formidable British fighter with a rotary engine. Because of the different engine construction philosophy, the two fighters were very different aircraft. The Camel was highly maneuverable thanks to the centre of gravity pushed very far forward and also because of the sheer inertia of the rotating engine, which made it very fast in a right turn. But the Camel was an unforgiving airplane, dangerous to less experienced pilots. The SE.5a, although very fast, was to the contrary a very stable and forgiving fighter. It was not as agile as the Camel, but still agile enough. And above 10,000 ft it was clearly superior not only to the Camel, but also to most enemy aircraft. Furthermore, the armament of one fixed, fuselage mounted Vickers machine gun, supplemented by a Lewis machine gun affixed to the top of the upper wing made it possible for pilots to attack a high-flying enemy, sneaking up beneath it unobserved. Some pilots questioned this armament arrangement, with two fixed Vickers suggested as a better solution, but early problems with the Constantinesco synchronizing gear spoke against it. In the end, the SE.5 was the first fighter with two machine guns. The Camel entered the field later in 1917. For SE.5a pilots, it was quite easy to pull down the wing mounted Lewis machine gun for reloading, but changing the drum and pushing the weapon back into firing position was a different story. The slipstream could even ram the removed drum into the pilot's face. But, pilots learned how to get the best from the SE.5a, the best of them leading the way. Apart from the aforementioned Albert Ball, there was, for example, James McCudden, a former sapper and air mechanic, later an ace with 57 kills, who used his skills to optimise the engine of his SE.5a for use in high level solo patrols against high-flying Rumpier observers. While 17,000 ft was the ceiling for the usual SE.5a, McCudden was capable of sorties of up to the 20,000 ft level. Another of the more famous men of the RFC, Edward C. Mannock, developed tactics which allowed extraction of the best of the SE.5a's capabilities.

Hisso and Viper

Problems with both supply and reliability of the 200hp Hispano-Suiza (nicknamed 'Hisso') engines troubled the SE.5a throughout its service career. As a result, there were a number of engine modifications installed in the SE.5a, both from the French supplier of the Hispano-Suiza, as well as from the British Wolseley firm, whose engines were usually further developments of Hispano-Suiza designs. With the earlier geared engines, the prop shaft was driven by a reduction gear and the propeller rotated counter clockwise (from the pilots perspective). The later direct drive engines had the propeller rotating clockwise. As Hispano Suiza supplied most of the early engines, the nickname 'Hisso' was used for all the planes with the geared engine, whether it came from Hispano-Suiza or Wolseley. For later production, the more reliable direct drive Wolseley Viper became the standard engine and aircraft so equipped were nicknamed 'Viper', again without distinction between suppliers. After the armistice a great sale of army surplus was held, and many planes were offered to the public, including the SE.5a. The price of one airworthy plane was 5 £, which translates to some 1,500 £ at today's values. Some retired pilots, who never flew the SE.5a during the war, brought one just to make one test flight, returning the plane with a discount. Such was the reputation of the SE.5a, enticing the pilots to try them, even if it did cost them a sizeable amount of money! Many of SE.5as were actually sold and were used in air races and also for 'Sky-Writing' purposes in advertising.

úvodem

Royal Aircraft Factory SE.5a je považován za jeden z nejrychlejších a nejúčinnějších stíhacích letounů 1. světové války. Nicméně příběh tohoto „Spitfiru Velké války“, jak je SE.5a někdy označován, rozhodně nebyl bezproblémový. SE.5 (Scout Experimental 5) zkonstruovali Henry Folland, John Kenworthy a major Frank Gooden jako stíhací letoun poháněný novým motorem V8 Hispano-Suiza 8Aa o maximálním výkonu 150 koní (110 kW). Jak se rotační motory blížily maximu svého vývojového potenciálu, byly právě řadové, kapalnou chlazené pohonné jednotky považovány za slibnou cestu k dalšímu zvyšování výkonů. První prototyp se poprvé vznesl 22. listopadu 1916, čímž byla zahájena poněkud trnitá cesta k jednomu z nejlepších letounů 1. světové války. Nový motor měl technické problémy, dalšími problémy trpěla konstrukce draku, především křídla. Dva první prototypy byly ztraceny při haváriích, z nichž jedna stála život i továrního šéfpilota společnosti RAF a jednoho z konstruktérů F. W. Goodena (28. ledna 1917). Problémy konstrukce byly částečně vyřešeny u třetího prototypu, který se již stal předobrazem první produkční verze nového stíhače.

SE.5 byly zavedeny do výzbroje nejprve u 56. squadrony RFC v dubnu 1917. Tato jednotka byla domovem celé řady stíhacích es. Jedním z nich byl Albert Ball, který se stal hybnou silou proměny SE.5 ve skutečně vynikající letoun. Nový stíhač byl totiž přijat s rozpaky kvůli nezvykle vysoké pozici sedačky pilota, velkému větrnému štítu, který jej měl chránit, a výzbroji sestávající z kulometu Vickers ráže 7,7 mm montovaném na trupu a Lewisem stejné ráže umístěném na horním křídle. Ball pracoval společně se svým mechanikem po nocích a odstraňoval menší i větší problémy, na které piloti postupně přicházeli. Většina modifikací byla následně na úrovni squadrony přijata. Velký větrný štít byl nahrazen klasickým a pozice sedadla se snížila na obvyklou úroveň. I tak si piloti pochvalovali dobrý výhled do všech stran. Změny navržené piloty 56. squadrony byly záhy zavedeny také do sériové výroby. Poslední kusy SE.5, vyrobené v červenci 1917, byly navíc vybaveny výkonnější verzí motoru Hispano-Suiza 8Ab s výkonem 200 koní (150 kW), což dalo vzniknout verzi SE.5a. Výroba SE.5 tak byla zastavena po pouhých 77 vyrobených kusech a naplno se rozběhla výroba verze SE.5a v celkem šesti továrnách: Vickers (2164 kusů), Austin Motors (1650 kusů), Air Navigation and Engineering Company (560 kusů), Wolseley Motors Limited (431 kusů), Martinside (258 kusů) and Royal Aircraft Factory (200 kusů). Americký Curtiss Aeroplane and Motor Company postavil jeden exemplář, který byl vzorovým kusem pro zamýšlenou výrobu tisícovky SE.5a, které měly primárně zaměřit k americkým squadronám bojujícím v rámci Amerického expedičního sboru. Příměří však znamenalo konec tohoto plánu.

SE.5a je často porovnáván s jiným slavným britským stíhačem té doby, Sopwith Camelem, posledním významným britským letounem s rotačním motorem. Vzhledem k principiálně rozdílným pohonným jednotkám se však jednalo o velmi odlišné letouny. Camel byl nesmírně obratný díky těžišti posunutému extrémně dopředu a také díky obrovskému reakčnímu momentu motoru Clerget, který umožňoval provádět velmi rychlé pravé zatáčky. Jenže Camel byl také letoun náročný na pilotáž, pro nezkoušené piloty vysloveně nebezpečný. SE.5a byl naproti tomu nejen rychlý, ale také velmi stabilní a snadno ovladatelný. Nebyl tak hbitý jako Camel, nicméně stále dostatečně hbitý pro manévrový boj, navíc ve výškách nad 3000 m měl již jasně navrch nejen nad Camelem, ale hlavně nad téměř všemi stroji protivníka. Určitou výhodou představovalo i netradiční uspořádání výzbroje s kulometem na horním křídle, který umožňoval pilotům přiblížit se nepozorovaně výše letícím nepříteli zespuza a výkopným Lewisem na něj zaútočit. Někteří piloti však tuto výzbroj zpochybňovali a dali by přednost dvěma trupovým Vickersům. Nicméně problémy provázející zpočátku synchronizaci Constantinesco hovořily proti. Pro piloty SE.5a bylo stažení kulometu z křídla dolů pro přebití velku snadné, nicméně výměna zásobníku a vysunutí kulometu zpět do palebné pozice, to už bylo něco zcela jiného. Proud vzduchu mohl dokonce vmést uvolněný prázdný zásobník pilotovi do tváře. Letci se nicméně naučili, jak dostat z SE.5a to nejlepší. Cestu přitom ukazovali ti nejlepší z nejlepších. Po Albertu Ballovi to byl například James McCudden, bývalý ženista a letecký mechanik, později eso s 57 sestřely, který využil svých znalostí motorů k vyladění svého SE.5a tak, aby mohl osamocené napadnout vysoké létající pozorovací Rumplery. Zatímco pro běžné SE.5a byl hraniční dostup 5200 m, McCuddenův stroj stoupal až do 6100 m. A jiný ze slavných mužů RFC Edward C. Mannock vyvinul taktiku boje, která umožňovala maximálně využívat předností SE.5a.

Hisso a Viper

Problémy s dodávkami a spolehlivostí motorů Hispano-Suiza, kterým se zkráceně přezdívalo „Hisso“, provázely SE.5a po celou jejich službu. Výsledkem byla spousta modifikací pohonných jednotek jak u Francouzů dodávaných Hispano-Suiza, tak u britských motorů Wolseley, které byly obvykle pouze dalším vývojem agregátů Hispano-Suiza. U ranějších verzí byl motor osazen reduktorem a vrtule se otáčela z pilotova pohledu doleva. Pozdější motory již měly spolehlivější přímý náhon a vrtule se otáčela doprava. Protože firma Hispano-Suiza dodávala většinu motorů s reduktorem, byly tyto verze SE.5a hovorově označovány jako „Hisso“, ať už motor pocházel od francouzského dodavatele, nebo od britského. U motorů s přímým náhonem zase převládaly dodávky motorů Wolseley Viper a proto byly tyto stroje označovány jako „Viper“, opět bez rozlišování dodavatele. Po uzavření příměří organizovala britská vláda velký výprodej válečných přebytků a veřejnosti byly nabízeny k odkoupení i vojenské letouny. SE.5a byly mezi nimi, prodávaly se po pěti librách šterlinků, což je dnes zhruba ekvivalent 1500 liber šterlinků. Někteří piloti, kteří neměli to štěstí si s SE.5a za války zalétat, stroj zakoupili, provedli s ním jeden testovací let a se slevou jej zase vrátili. Takovou měl na konci války SE.5a pověst, že byli ochotni zaplatit za to, aby si jej mohli aspoň vyzkoušet. Řada z nich ale byla skutečně odkoupena a provozována při leteckých závodech, nebo při „psaní na oblohu“, což byl v meziválečných letech populární způsob reklamy.

ATTENTION



UPOZORNĚNÍ



ACHTUNG



ATTENTION



注意



Carefully read instruction sheet before assembling. When you use glue or paint, do not use near open flame and use in well ventilated room. Keep out of reach of small children. Children must not be allowed to suck any part, or pull vinyl bag over the head.



Před započítím stavby si pečlivě prostudujte stavební návod. Při používání barev a lepidla pracujte v dobře větrané místnosti. Lepidla ani barvy nepoužívejte v blízkosti otevřeného ohně. Model není určen malým dětem, mohlo by dojít k požití drobných dílů.

INSTRUCTION SIGNS * INSTR. SYMBOLS * INSTRUKTION SINNBILDEN * SYMBOLES * 記号の説明

OPTIONAL
VOLBABEND
OHNOUOPEN HOLE
VYVRTAT OTVORSYMMETRICAL ASSEMBLY
SYMETRICKÁ MONTÁŽREMOVE
ODŘÍZNOUTREVERSE SIDE
OTOČITAPPLY EDUARD MASK
AND PAINT
POUŽÍT EDUARD MASK
NABARVIT

PARTS



DÍLY



TEILE



PIÈCES



部品

PLASTIC PARTS

A> 2 pcs.

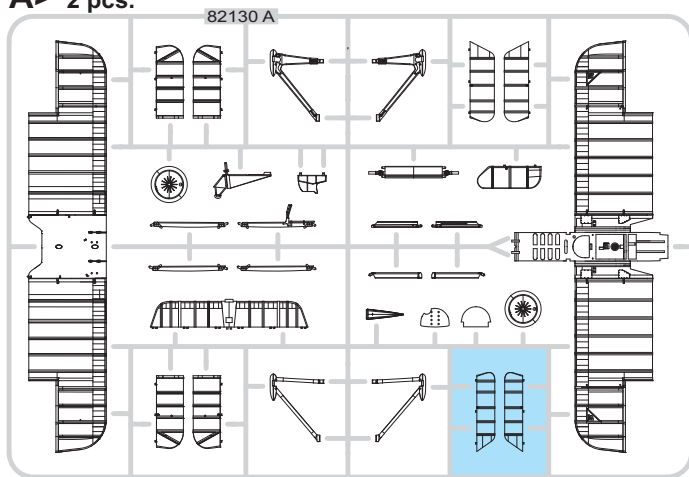

B> 2 pcs.

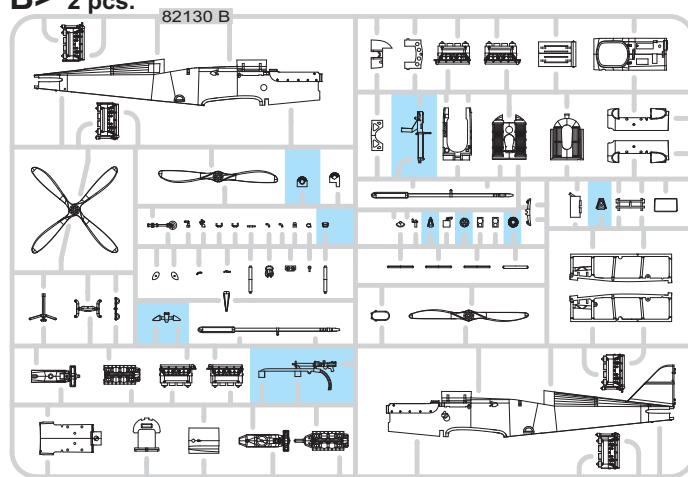

C> 2 pcs.

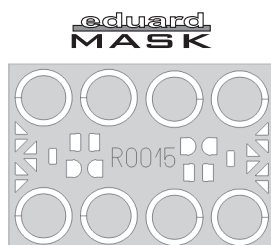
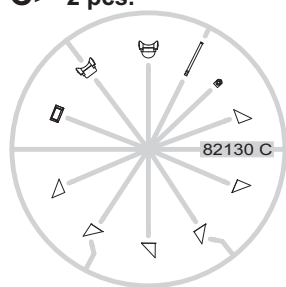
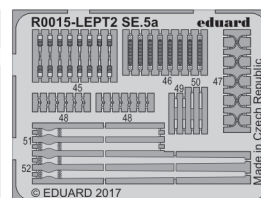
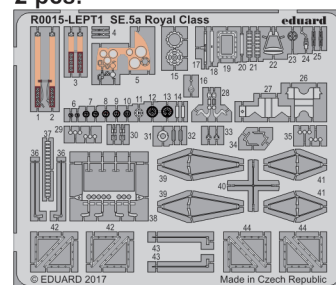
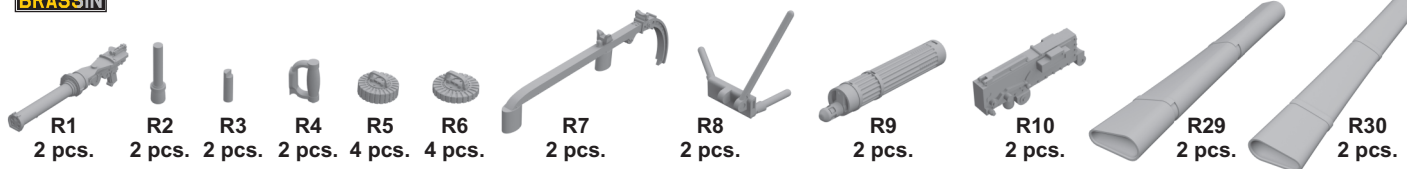
PE - PHOTO ETCHED DETAIL PARTS
2 pcs.eduard
BRASSIN RP - RESIN PARTS

-Parts not for use. -Teile werden nicht verwendet. -Pièces à ne pas utiliser. -Tyto díly nepoužívejte při stavbě. - 使用しない部品

COLOURS



BARVY



FARBEN



PEINTURE



色

GSI Creos (GUNZE)		
AQUEOUS	Mr.COLOR	
H 3	C3	RED
H 4	C4	YELLOW
H 5	C5	BLUE
H 8	C8	SILVER
H 11	C62	WHITE
H 12	C33	FLAT BLACK
H 33	C81	RUSSET
H 37	C43	WOOD BROWN

AQUEOUS		
	Mr.COLOR	
H 47	C41	RED BROWN
H 51	C11	LIGHT GULL GRAY
H 65	C18	BLACK GREEN
H 85	C45	SAIL COLOR
H 309	C309	GREEN
Mr.METAL COLOR		
	MC214	DARK IRON
	MC218	ALUMINIUM
	MC219	BRASS

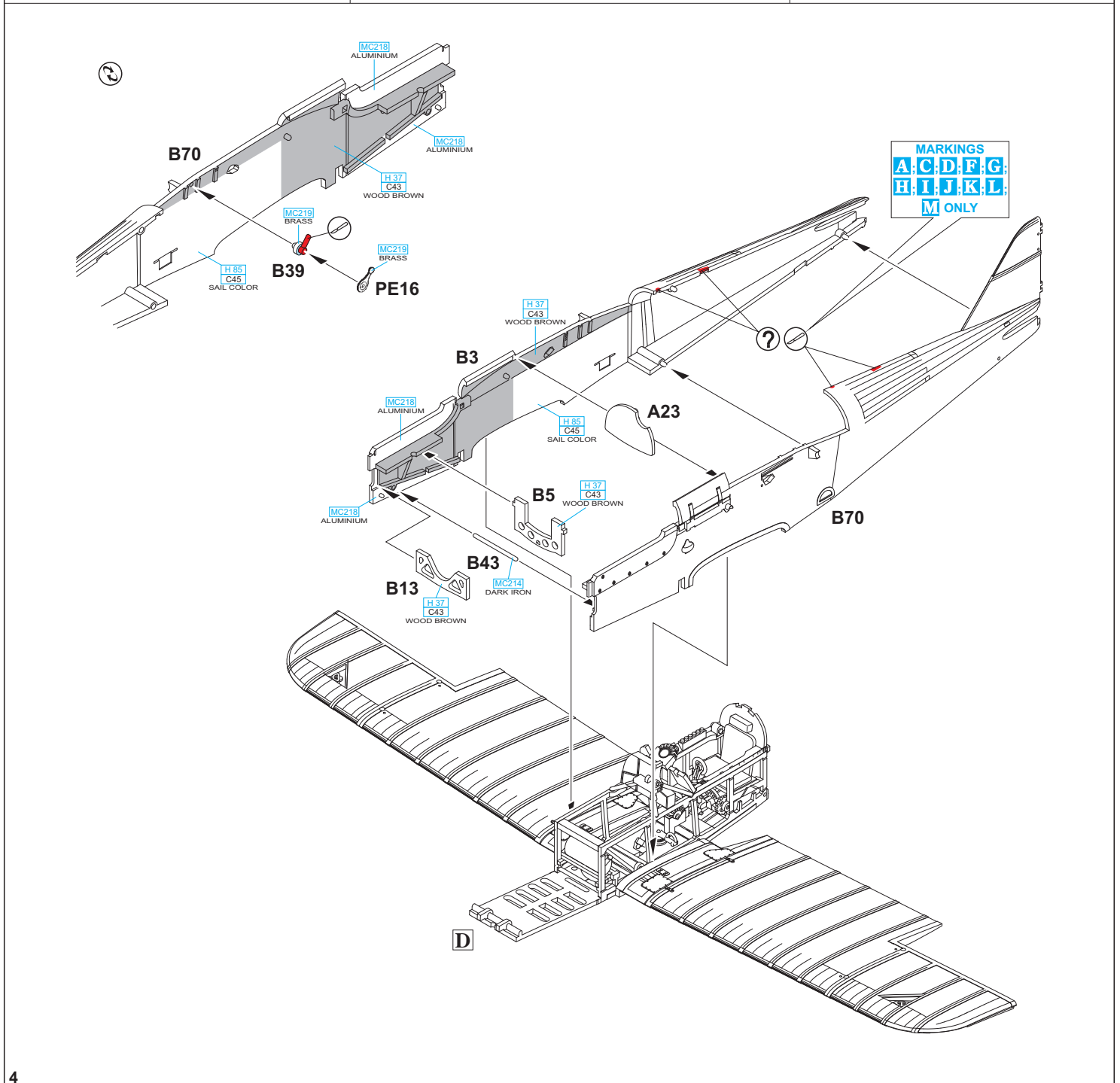
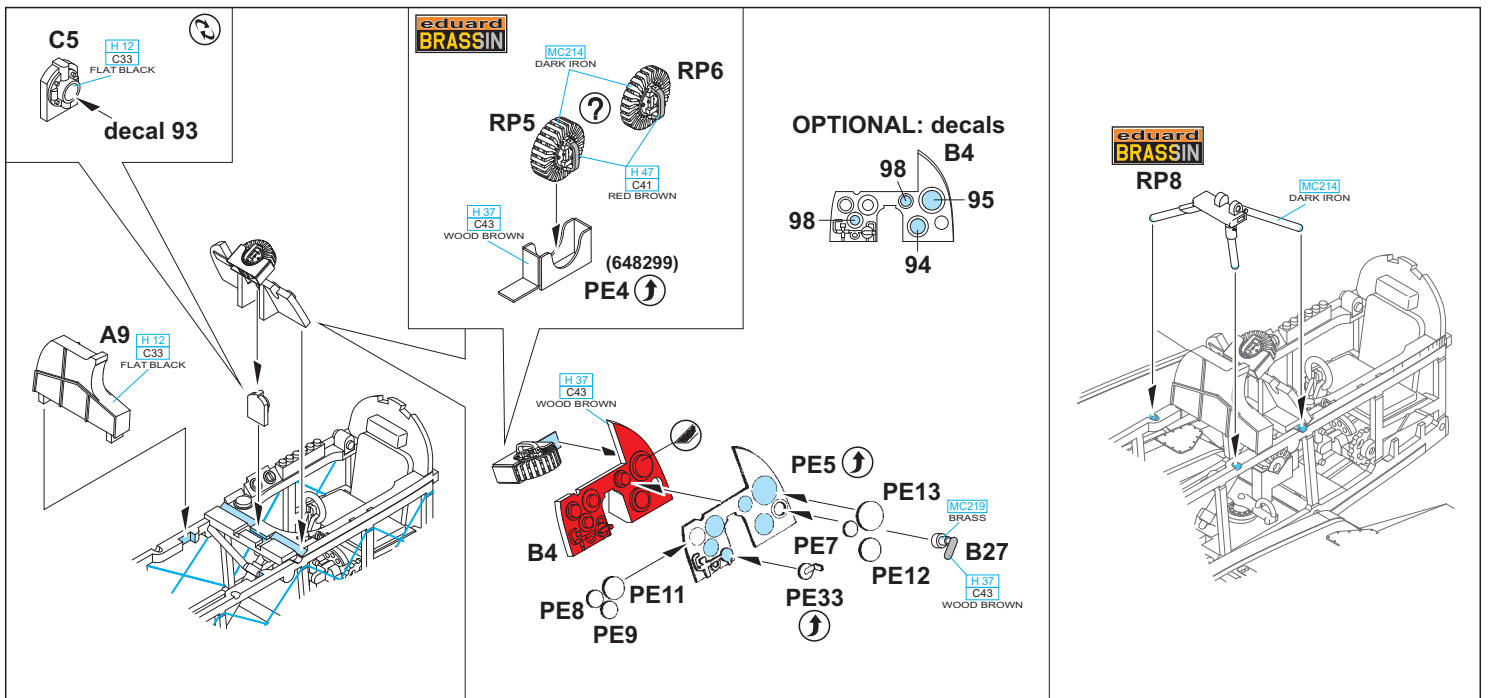

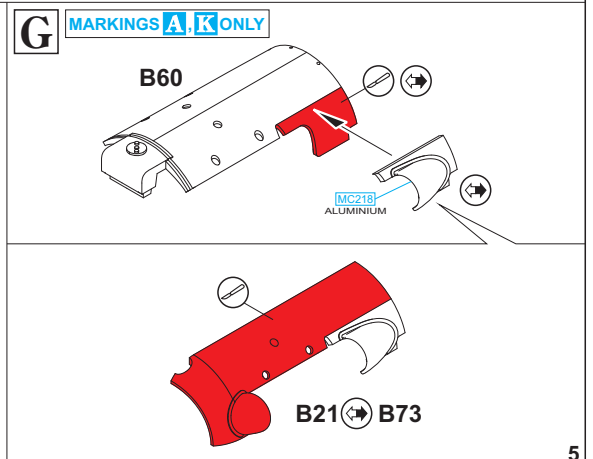
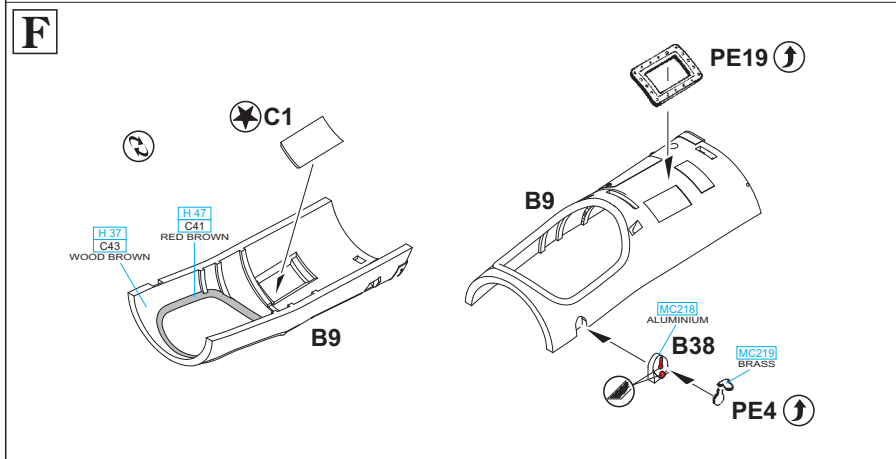
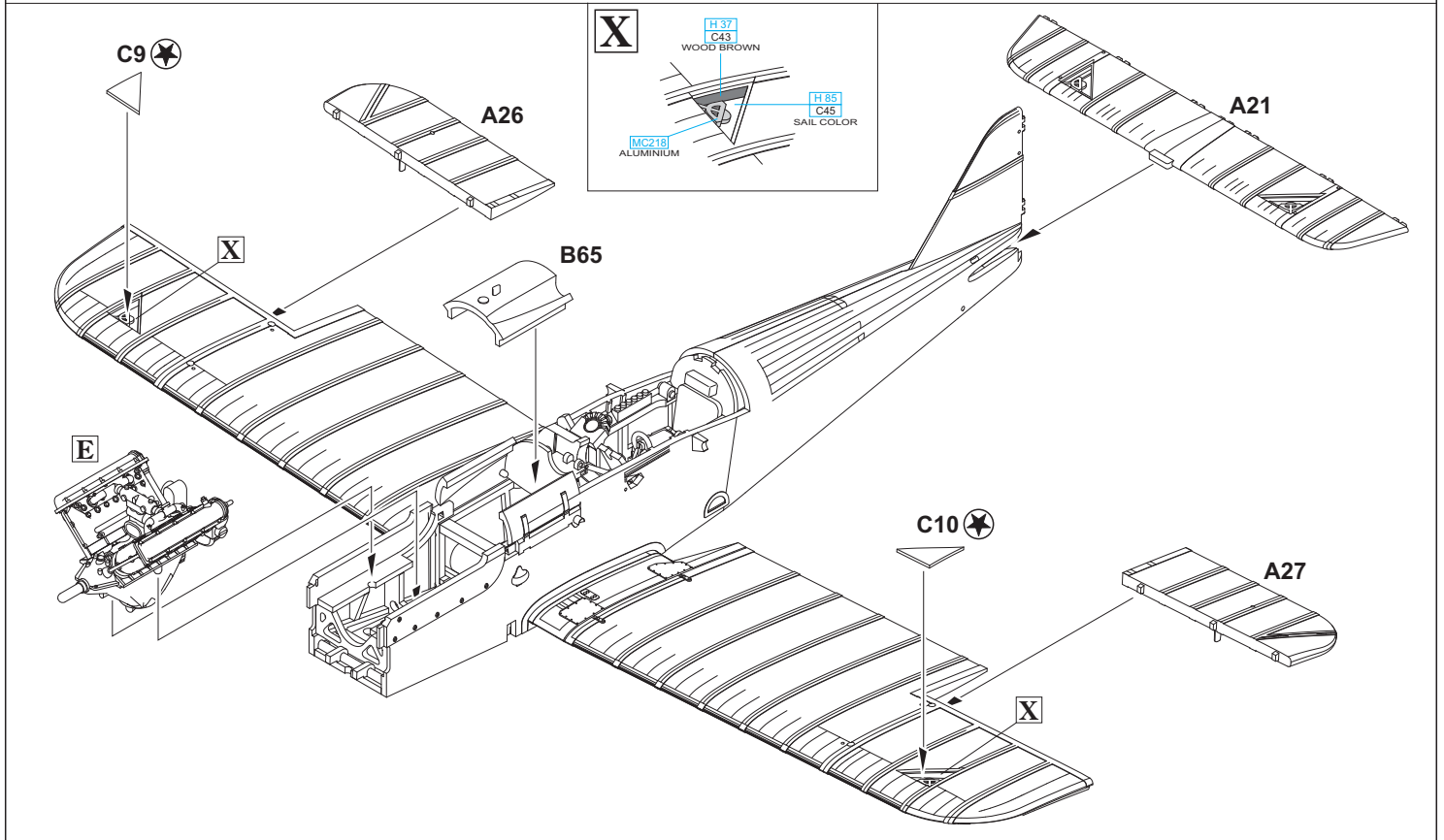
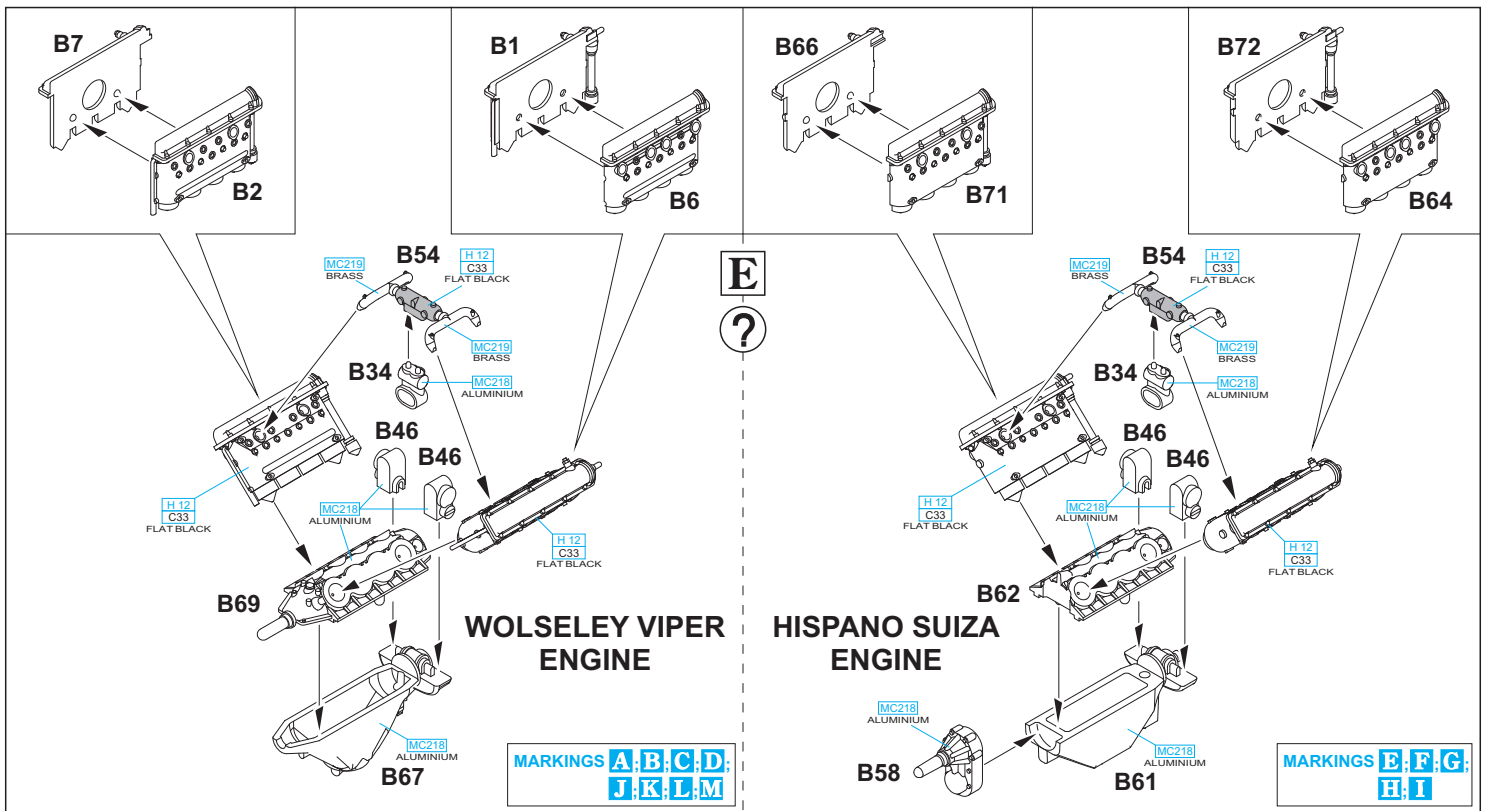

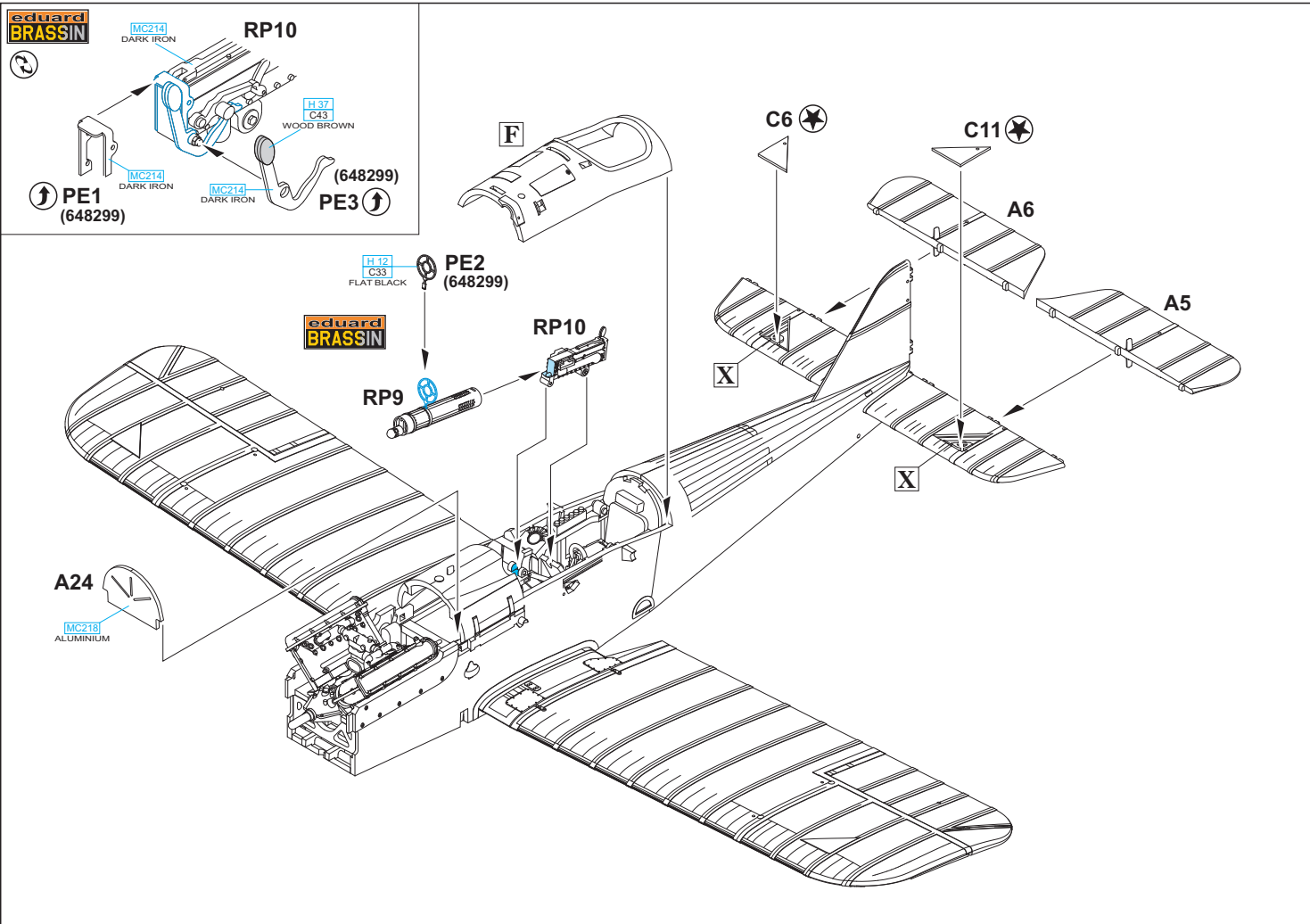

MARKINGS **A, B, C, D, J, K, L, M**

SE.5a - WOLSELEY VIPER ENGINE

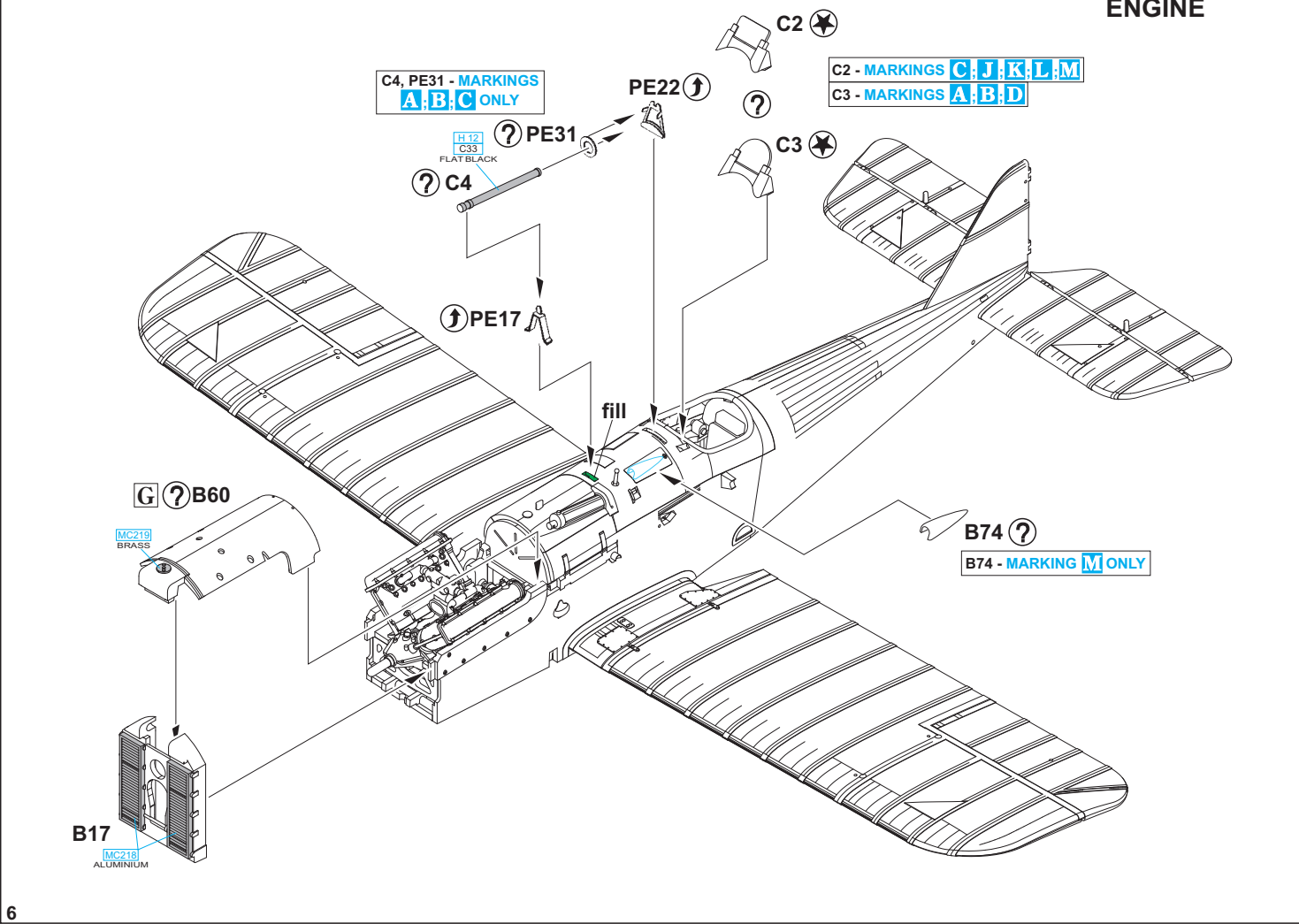

SE.5a - HISPANO SUIZA ENGINE

MARKINGS **E, F, G, H, I**

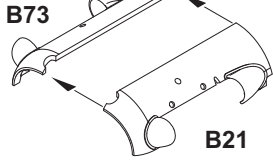

C4, PE31 - MARKINGS **E, F, H, I** ONLY

C2 - MARKINGS **H, I**
C3 - MARKINGS **E, F, G**

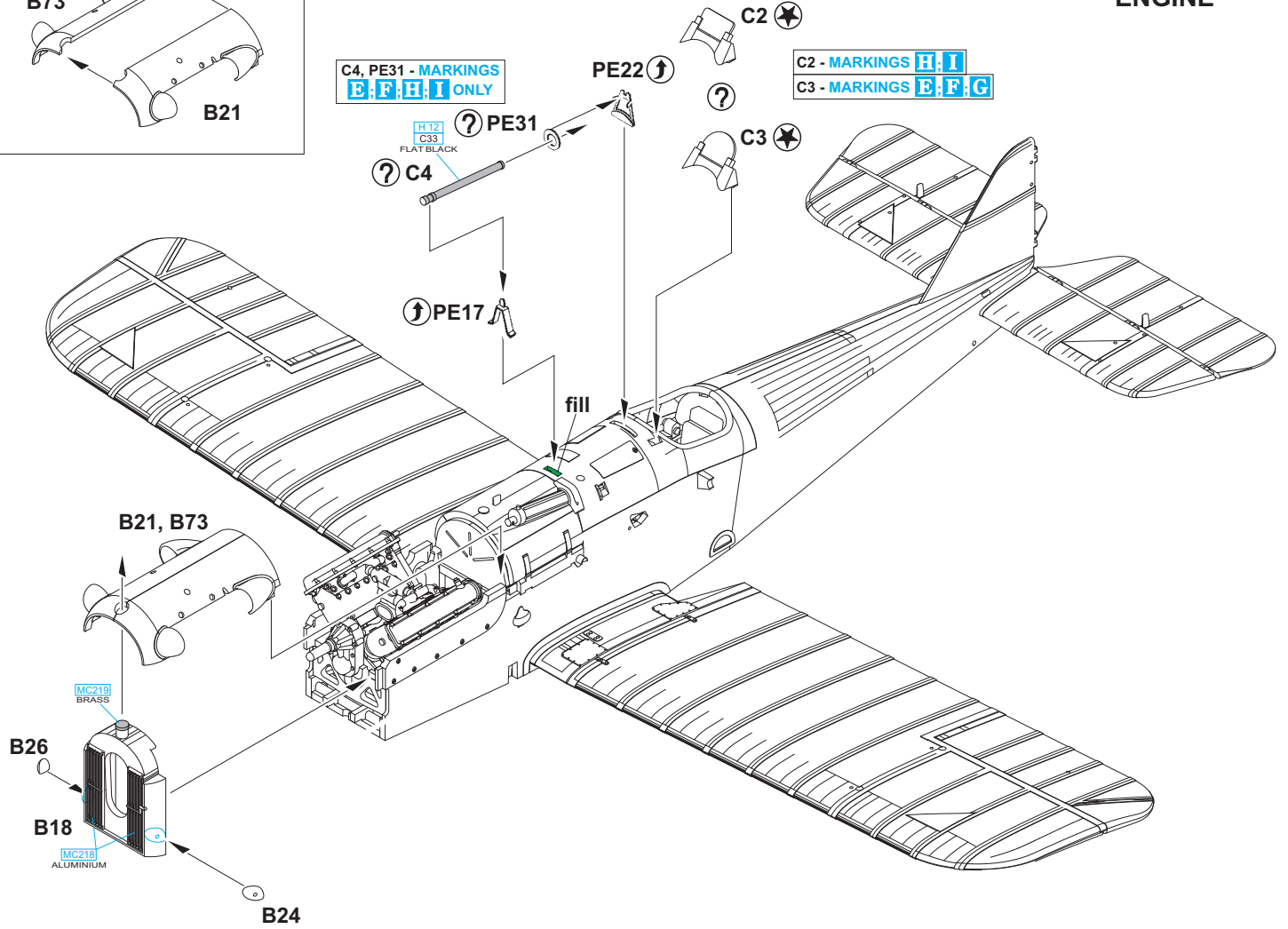

H (up arrow)

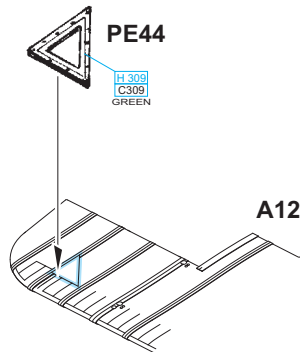
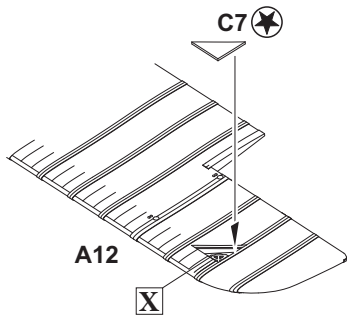

I

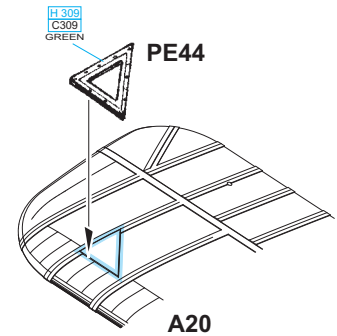

J (up arrow)

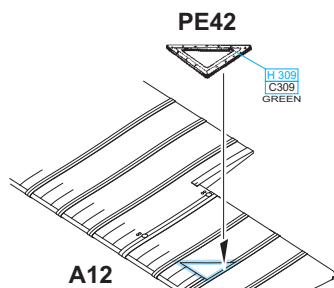
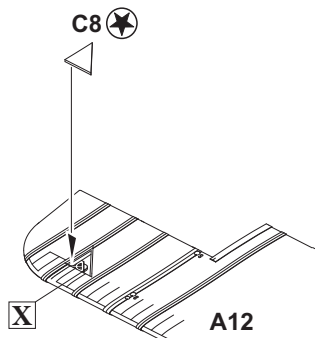

K

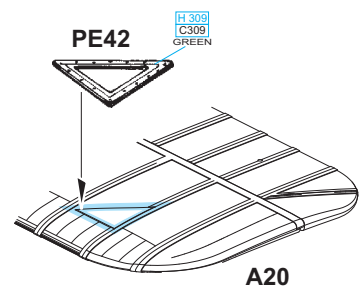

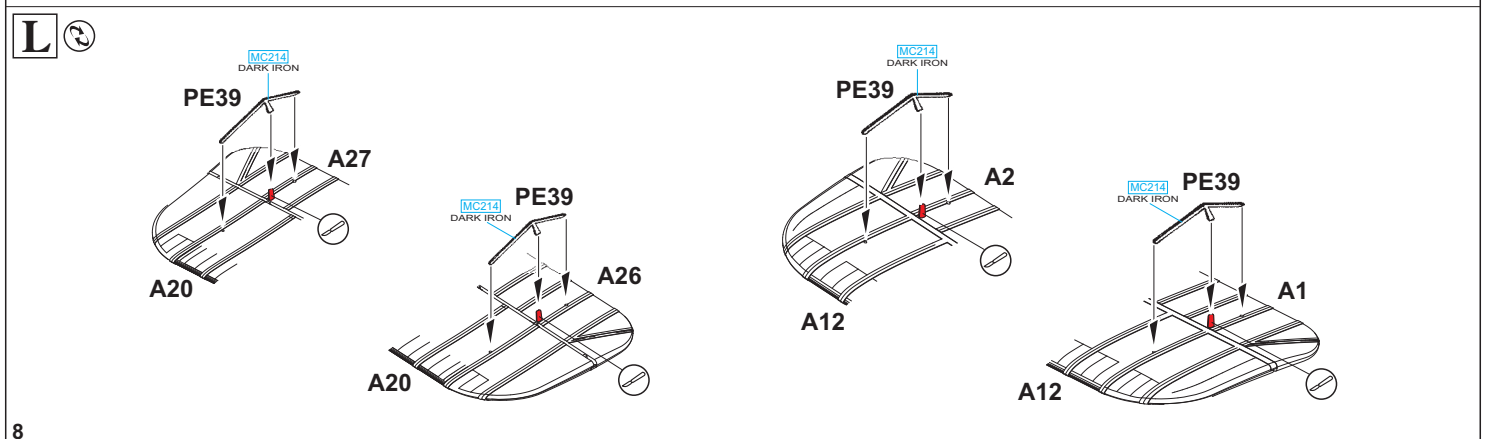
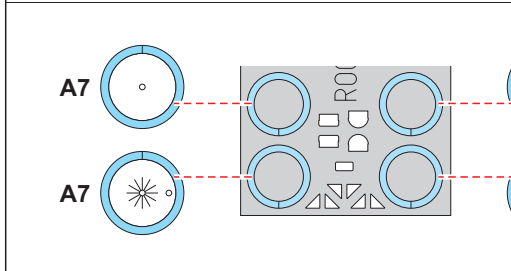
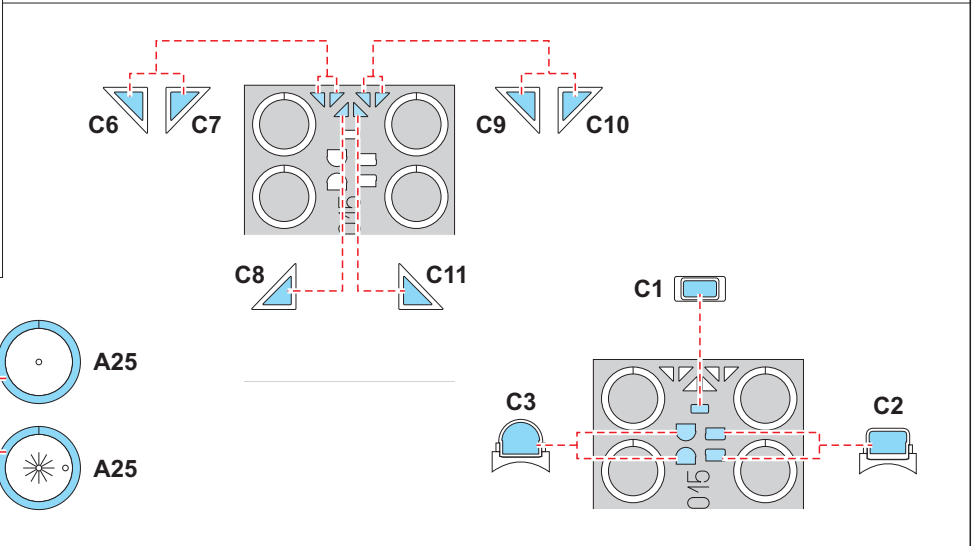
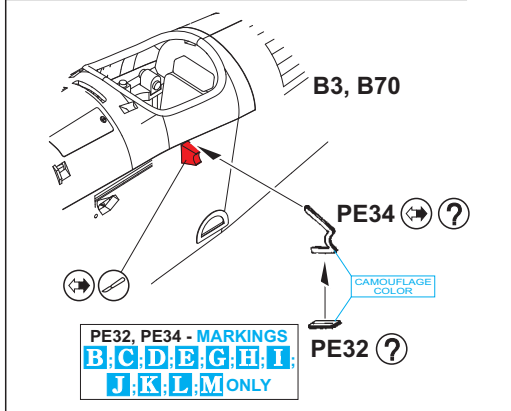
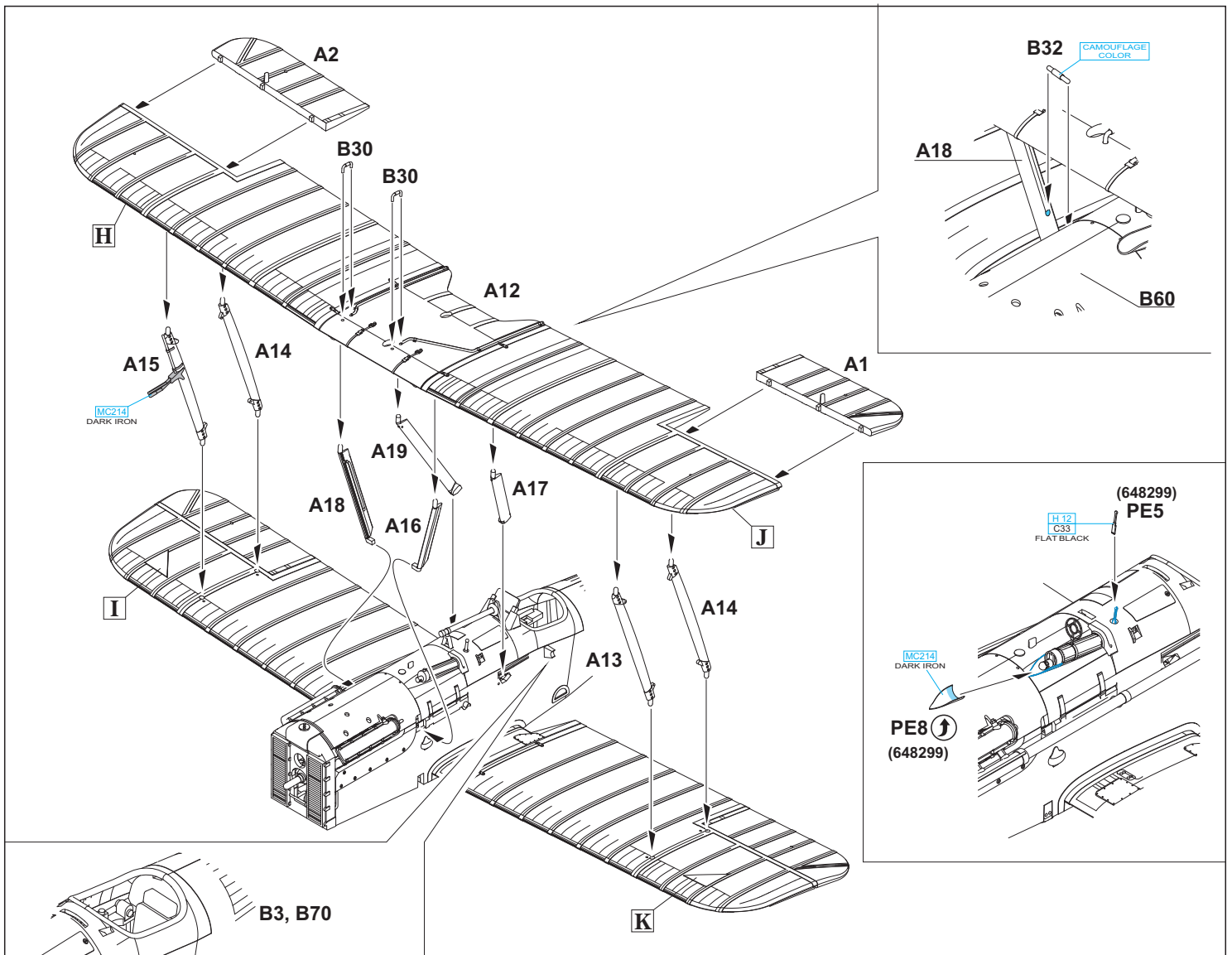

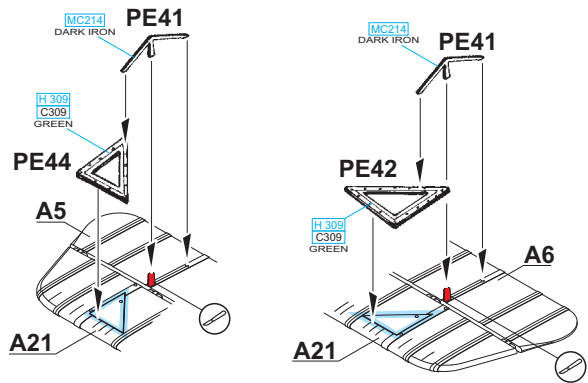
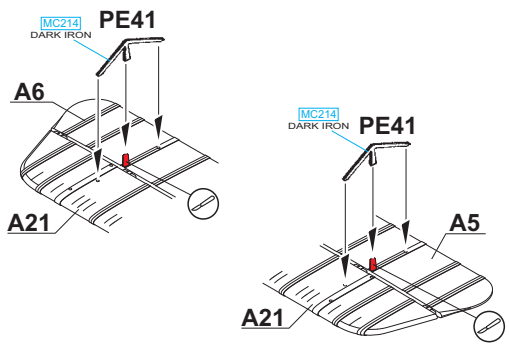
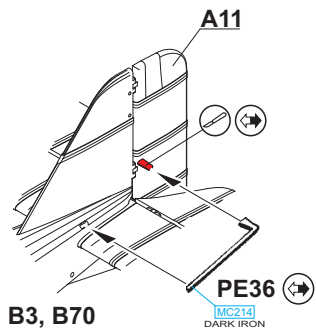
O**P****R**

6 pcs.

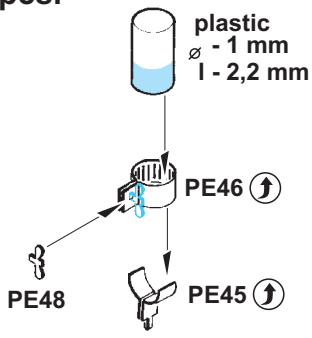
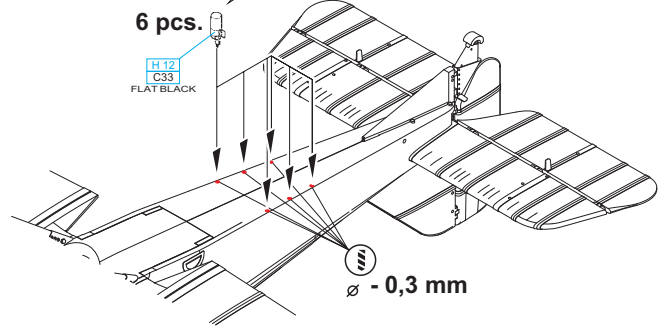
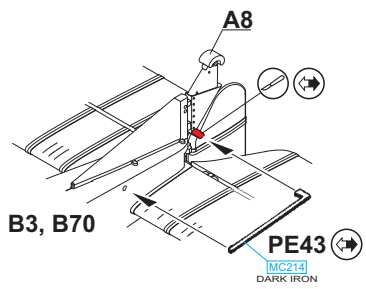
**T** MARKING A ONLY**S****U**

PE6, PE7, RP1, RP2, RP3, RP4, RP5 ? RP6 - MARKINGS
A, B, C, D, E, F, H, I, J, M ONLY

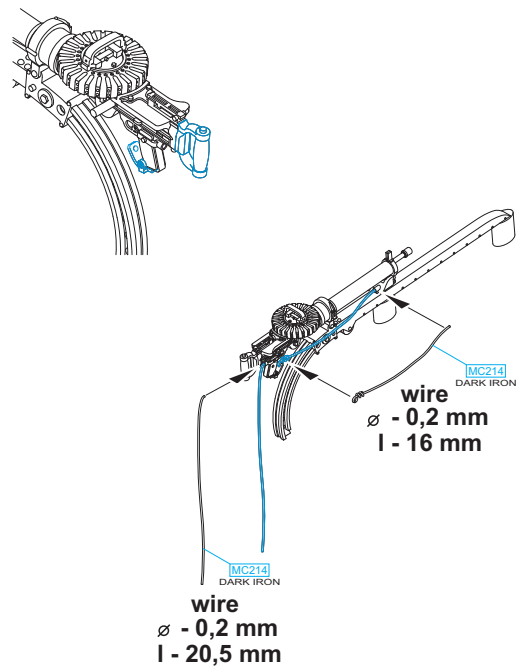
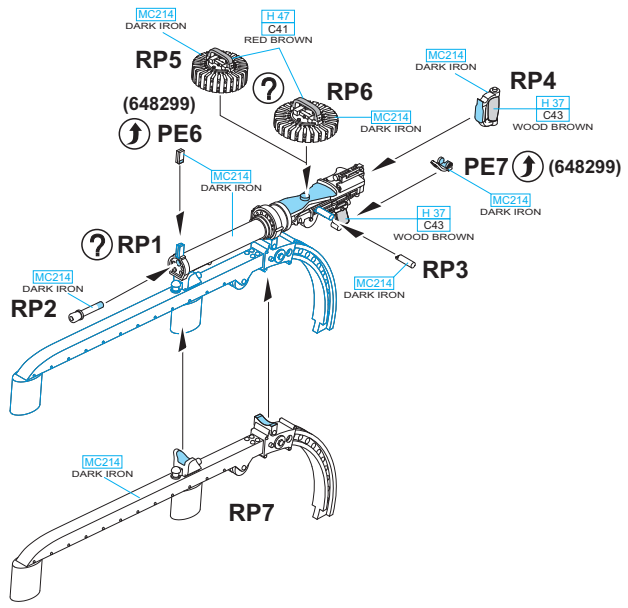

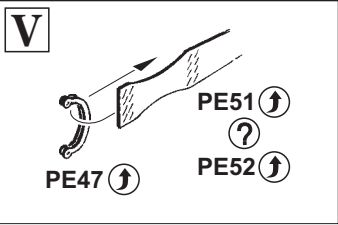

A22 - MARKINGS
A;C;D;F;G;H;I;
J;K;L;M ONLY

PE47, 52 - MARKING
A ONLY

PE47, 51 - MARKING
M ONLY

A22 ?

H47
C41
RED BROWN

edward
BRASSIN

PE47, 52 - MARKINGS
B;D;F;M ONLY

PE47, 51 - MARKING
M ONLY



B59

B59 - MARKING E

B10

B10 - MARKINGS
A;B;C;D;J;
K;L;M ONLY

B10 - PROPELLER FOR WOLSELEY VIPER ENGINE
B23, B59 - PROPELLERS FOR HISPANO SUIZA ENGINE

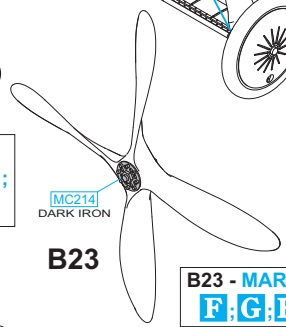

B23

B23 - MARKINGS
F;G;H;I

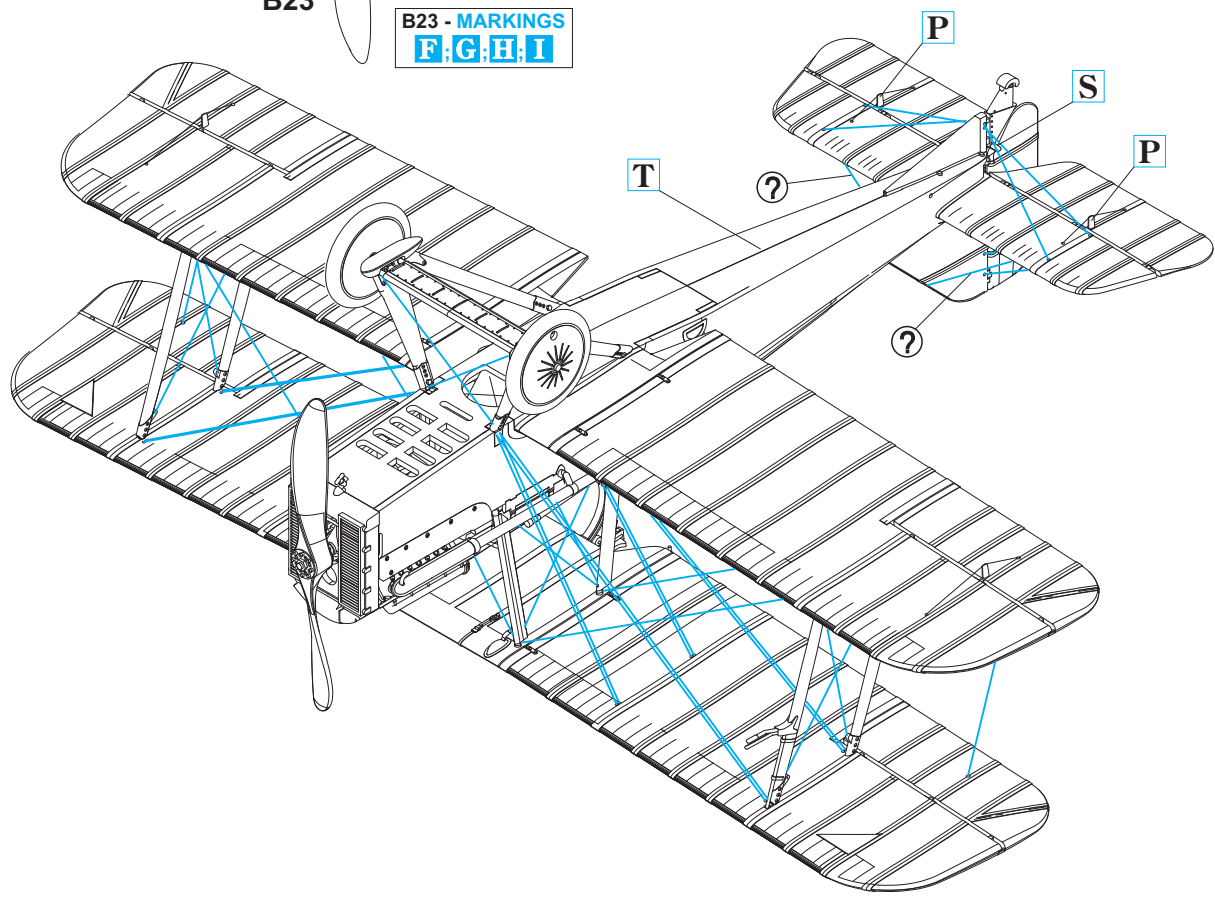

A C1803, flown by Capt. C. J. Truran, No. 143 Squadron, Detling, Great Britain, May 1918

No.143 Squadron was formed on February 1st, 1918 at Throwley and was equipped with the Armstrong Whitworth F.K.8. In March of the same year, it was re-equipped with the SE.5a and moved to Detling. On the night of May 19-20, the unit took part in the interception of the first German raid by Gotha bombers on London. 'Night fighting' SE.5a aircraft were camouflaged in a special coating called NIVO (Night Invisible Varnish Orfordness), and was also applied over the white rings in the national roundels. The white bands on the rudder were likely painted over with PC-10. There are six Holt flare holders below the fuselage.

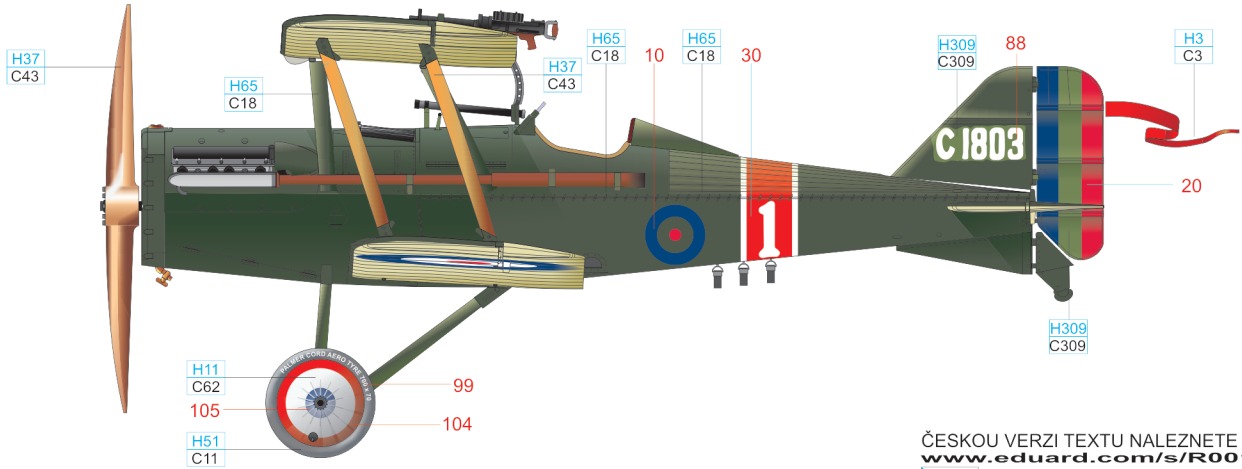

ČESKOU VERZI TEXTU NALEZNETE NA www.eduard.com/s/R0015

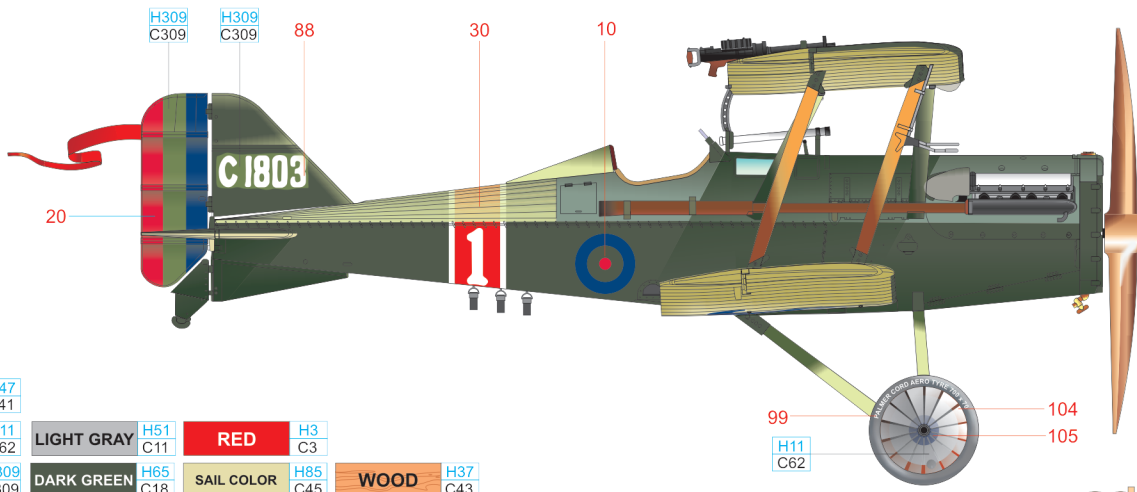
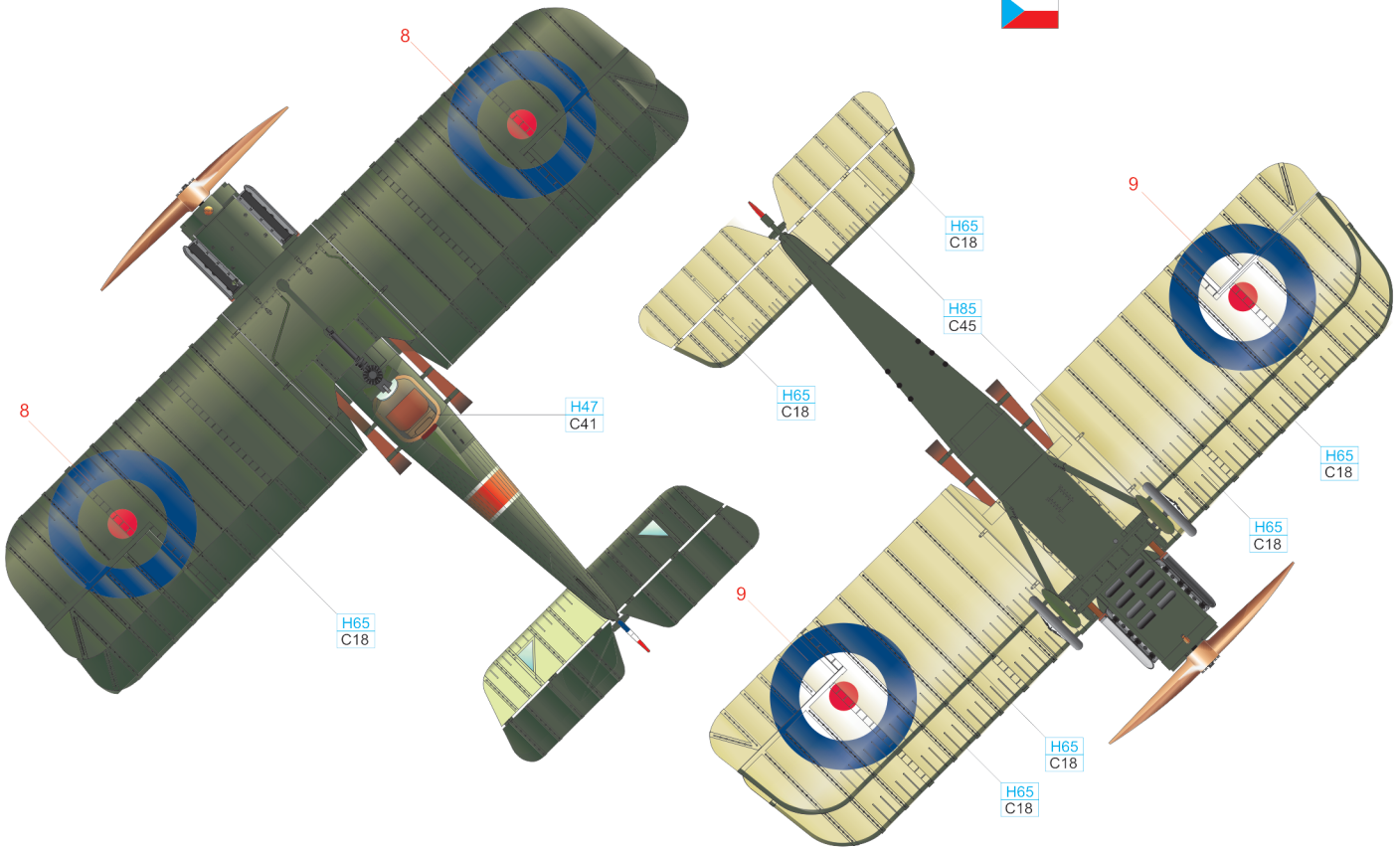

RED BROWN	H47 C41	WHITE	H11 C62	LIGHT GRAY	H51 C11	RED	H3 C3
GREEN	H309 C309	DARK GREEN	H65 C18	SAIL COLOR	H85 C45	WOOD	H37 C43

B C1904, flown by Maj. W. A. Bishop, No. 85 Squadron, Petit Synthe, France, June 1918

Canadian ace William Avery 'Billy' Bishop was born on February 8th, 1894 in Owen Sound, Ontario. He first served in the infantry in World War One, and later was accepted into the RFC as an observer. After recovering from injuries sustained during a take-off, he was assigned to go through pilot training, and became acquainted with the SE.5a in July 1917, while with No.60 Squadron. After returning from a tour of Canada to raise morale, he was made CO of the newly formed No.85 Squadron, also equipped with the SE.5a. By the end of the First World War, he had shot down 72 enemy aircraft and was awarded the Victoria Cross, the Distinguished Flying Cross and the Distinguished Service Order and Bar. Billy Bishop died on September 11th, 1956 in West Palm Beach, Florida. On this aircraft, Maj. Bishop shot down thirteen enemy aircraft. The marking on the side of the fuselage was that of No.85 Squadron.

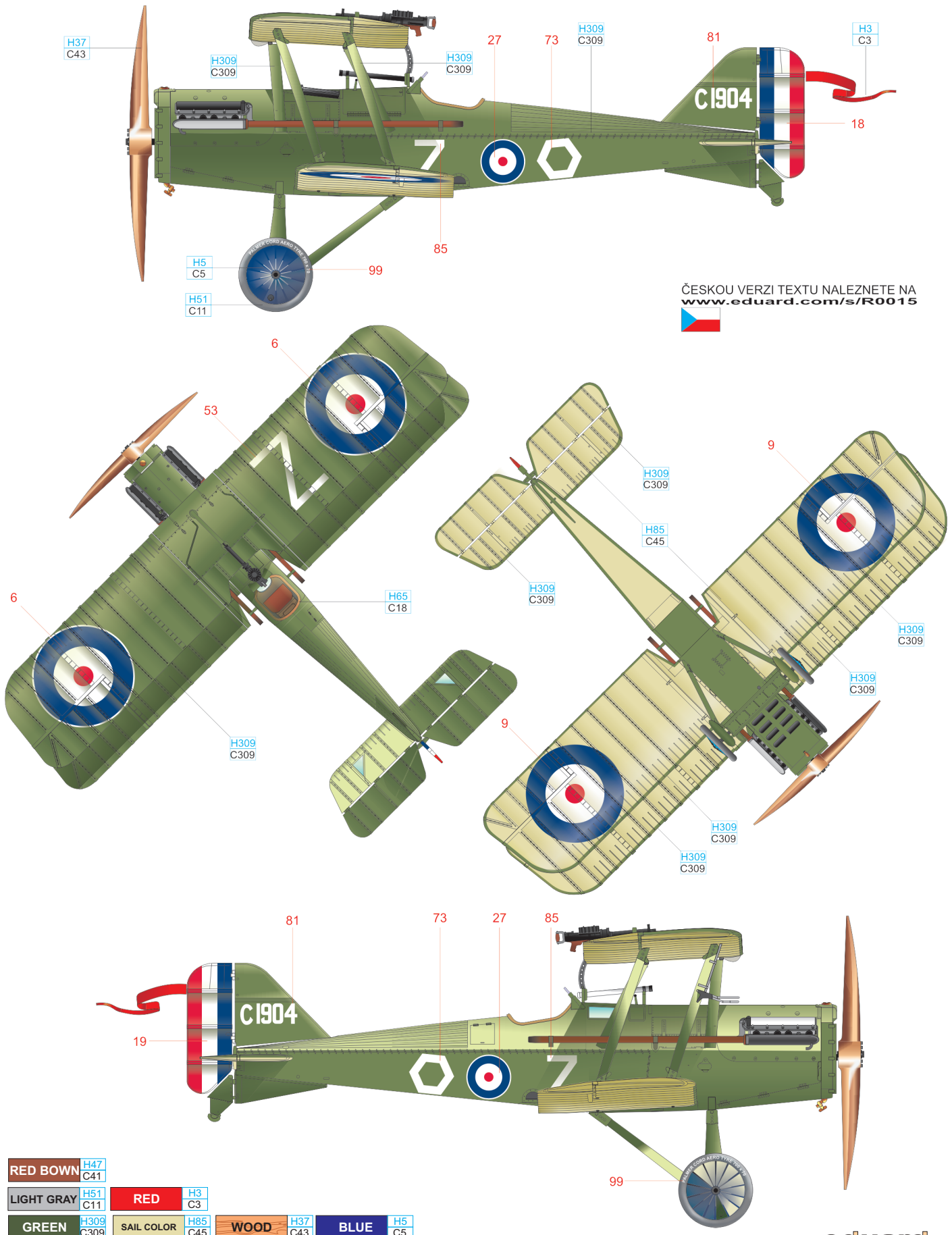

ČESKOU VERZI TEXTU NALEZNETE NA
www.eduard.com/s/R0015



RED BROWN	H47 C41	RED	H3 C3
LIGHT GRAY	H51 C11	WOOD	H37 C43
GREEN	H309 C309	SAIL COLOR	H85 C45
		BLUE	H5 C5

C D278, flown by Capt. E. Mannock, No. 74 Squadron, Clairmarais North, France, April 1918

Edward Corringham 'Mick' Mannock was born on May 24th, 1887 in Aldershot in Great Britain. He began the war in a very unorthodox way, that of a Turkish prisoner. In October 1914, when Turkey entered the war as a German ally, he worked for a British telephone company at the time when Britain committed to the Entente agreements on October 30th, 1914. However, he was repatriated in 1915 due to poor health. Despite being blind in one eye, he passed his medical exams and in April 1917, he gained his wings and was assigned to No.40 Squadron. In February 1918, he was named CO of the newly formed No.74 Squadron and On July 5th, 1918 of No.85 Squadron. He was killed when his SE 5a was shot down on July 26th, 1918. Mick Mannock gained seventeen of his 61 kills flying this machine. No.74 Squadron aircraft were adorned with white rectangles on their fuselages.

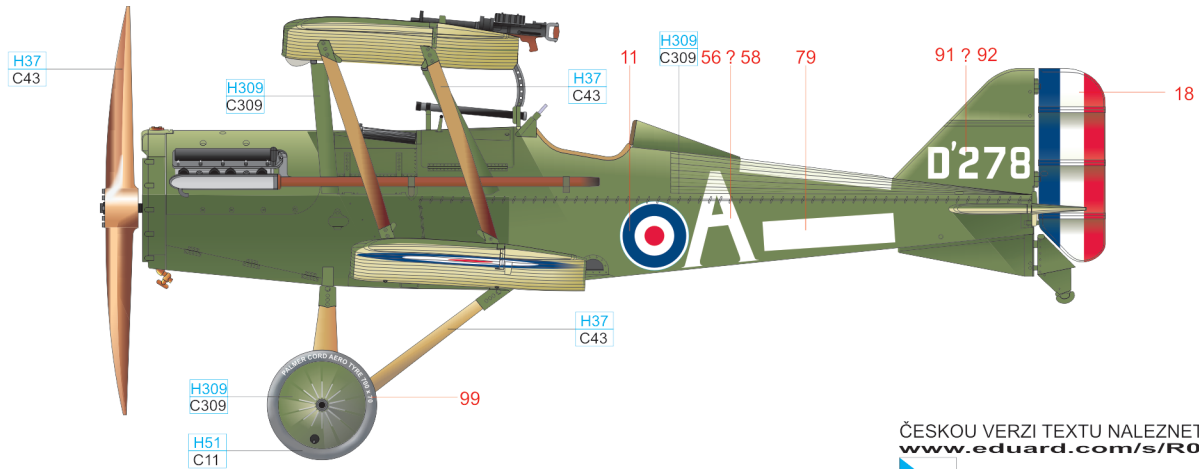

ČESKOU VERZI TEXTU NALEZNETE NA
www.eduard.com/s/R0015

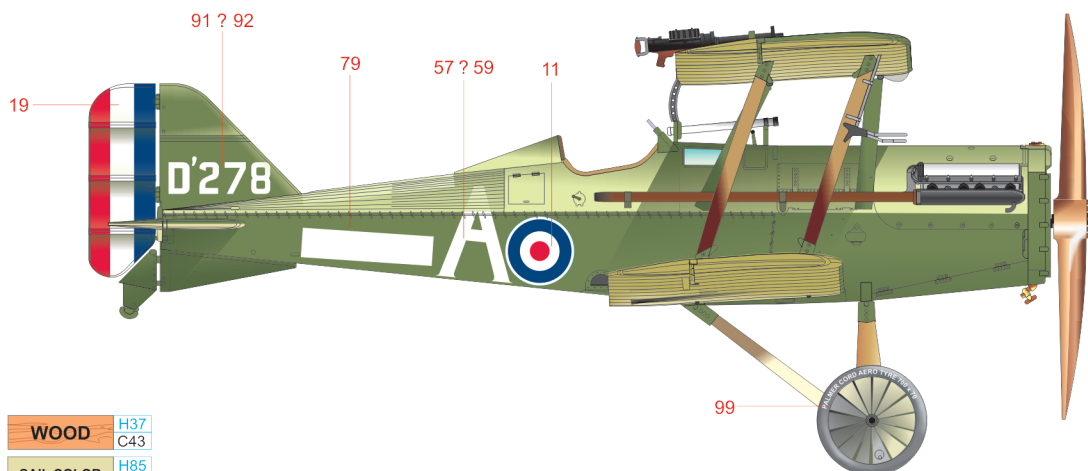
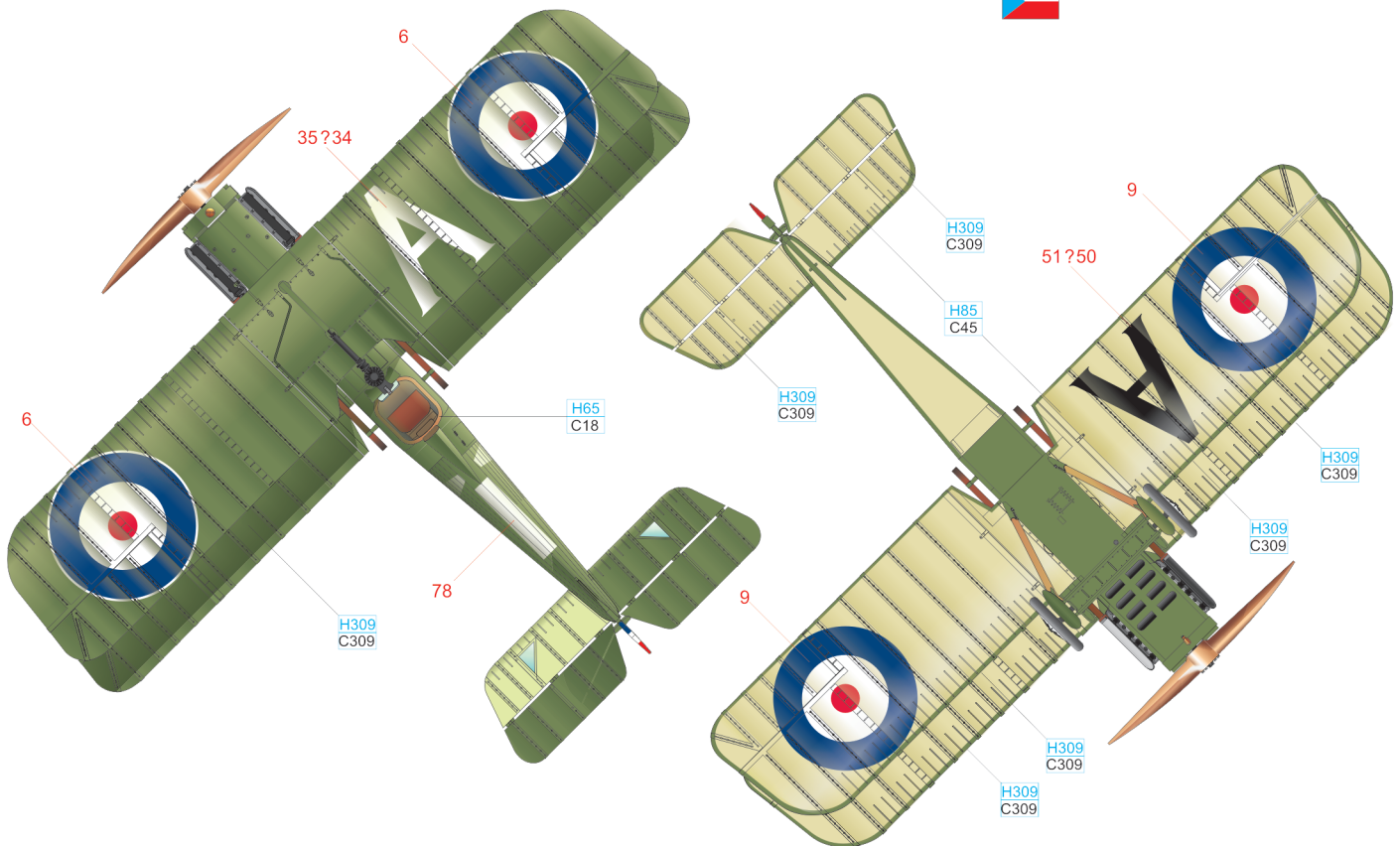

RED BROWN	H47 C41	WOOD	H37 C43
LIGHT GRAY	H51 C11	SAIL COLOR	H85 C45
GREEN	H309 C309		

D F5687, flown by Lt. J. A. Roth, No. 60 Squadron, Quiévy, France, November 1918

No.60 Squadron, RFC acquired its first SE.5, which was the predecessor to the SE.5a with a less powerful Hispano engine, in July 1917, becoming another in a list of users of this superb British aircraft. This was followed by delivery of the improved SE.5a, with which pilots of this unit gained further victories. During combat in the First World War, there was a total of twenty-five aces serving with No.60 Squadron (such as Albert Ball or William Avery Bishop) contributing to the unit's tally of 320 enemy aircraft. On November 7th 1918, No.60 Squadron accepted aircraft F5687 with a dedication inscription from Sallie Parker from New York. The aircraft also carried the No.60 unit marking consisting of two white bands at the end of the fuselage. Aircraft of 'B' Flight carried their individual markings on the sides of the cowling.

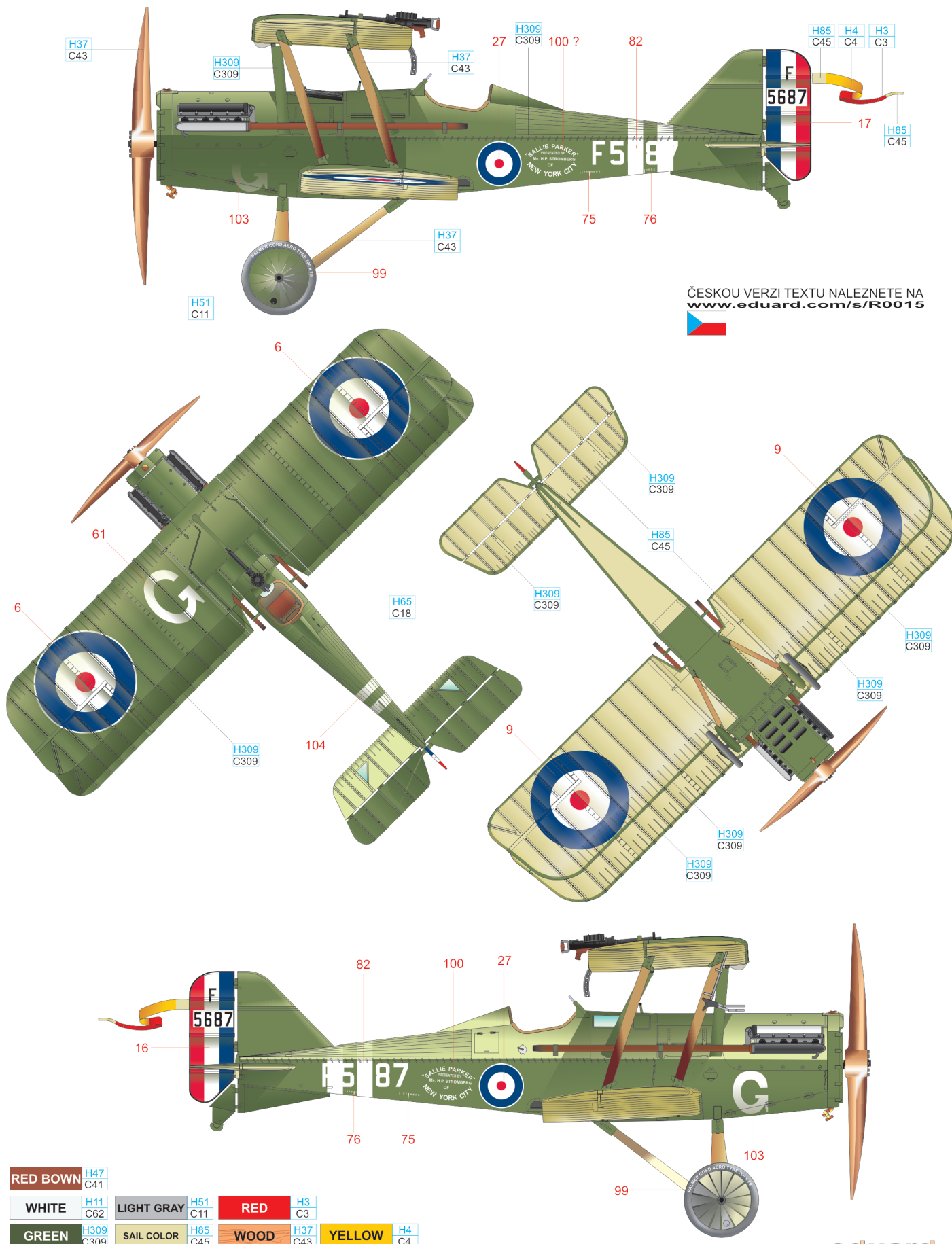

E B189, flown by Capt. J. H. Tudhope, No. 40 Squadron, Bruay, France, April 1918

With a total of ten enemy aircraft downed, the Canadian John Henry 'Tud' Tudhope elevated himself to the level of such No.40 Squadron names as Edward Mannock and Roderick Dallas. No.40 Squadron was formed at Gosport in 1916 and was not disbanded until 1957. Aircraft of No.40 Squadron carried two parallel vertical stripes on the rear fuselage until March 22nd, 1918. By that date, these markings were replaced by a zigzag line. At the same time, the aircraft letter was moved from the side of the fuselage to the top of the fin. A white diagonal stripe was added to the elevators.

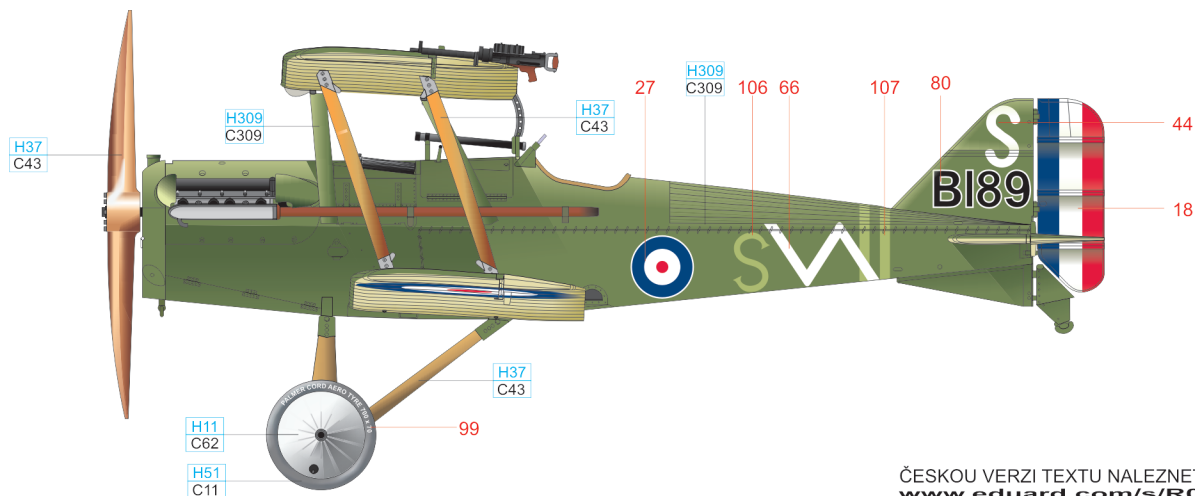

ČESKOU VERZI TEXTU NALEZNETE NA
www.eduard.com/s/R0015

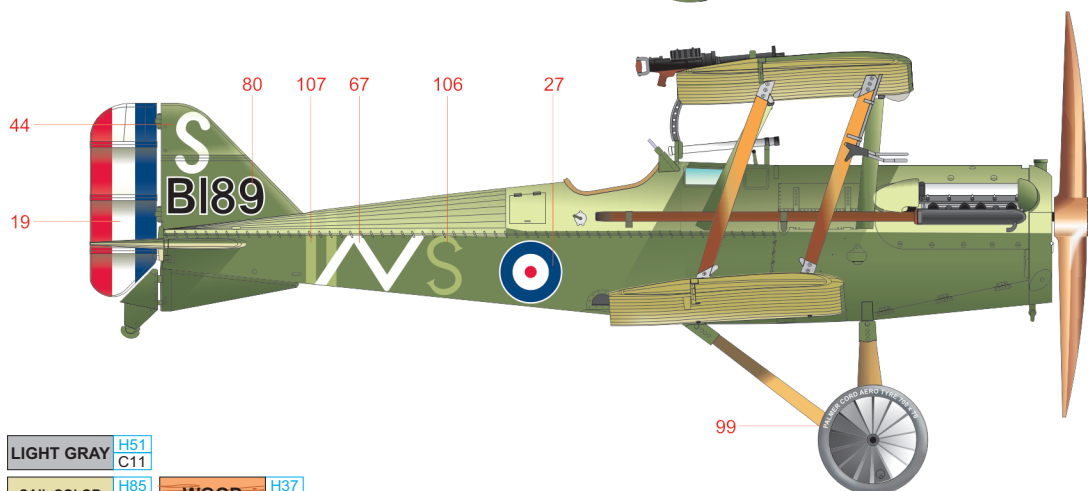
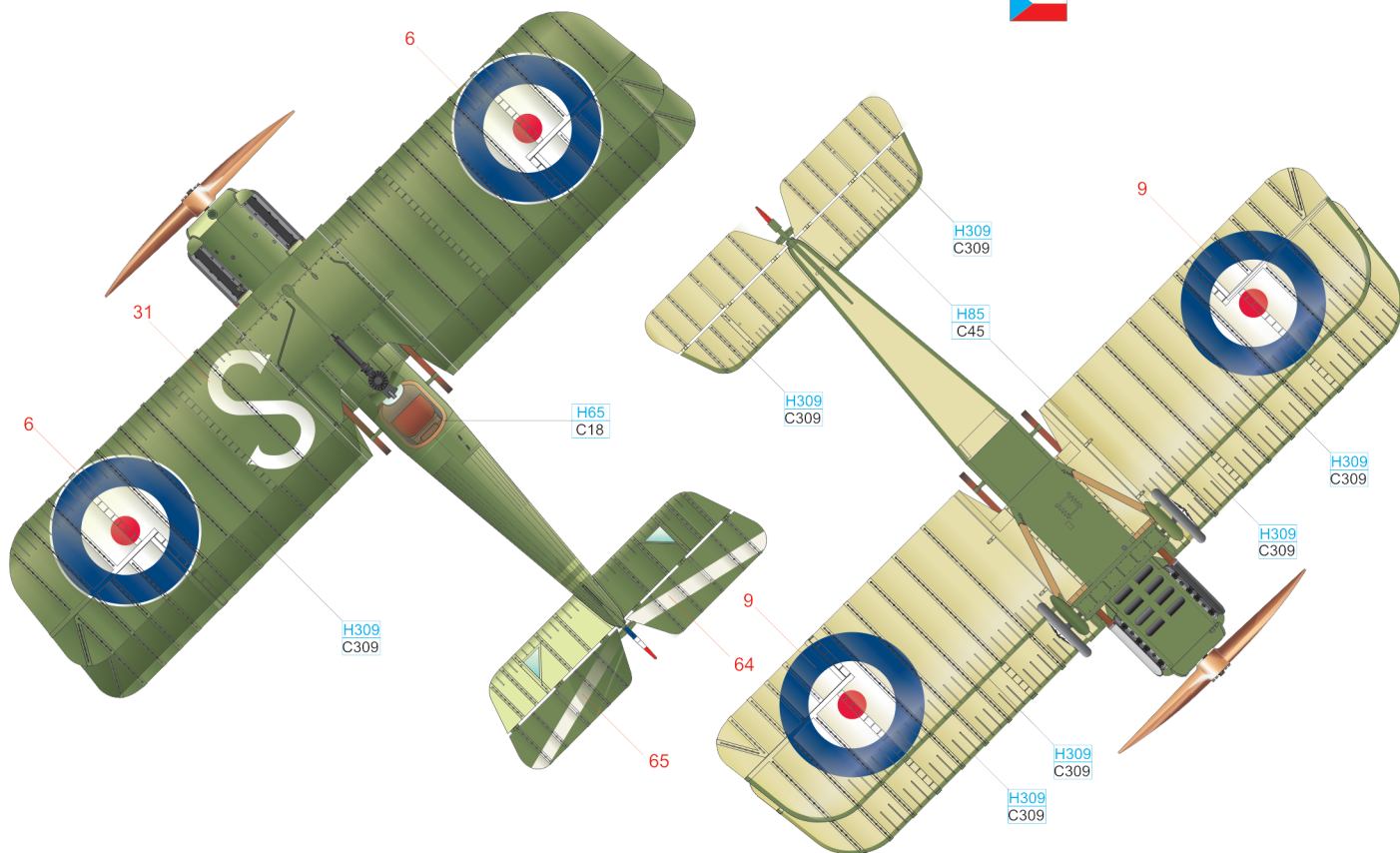

RED BROWN	H47 C41	WHITE	H11 C62	LIGHT GRAY	H51 C11	WOOD	H37 C43
GREEN	H309 C309	SAIL COLOR	H85 C45				

G B603, Training Unit, Great Britain, 1918

Unusual markings were carried by this aircraft, likely belonging to a training unit located in the British Isles. The aircraft was produced by Vickers and was powered by a Hispano-Suiza engine with a four blade propeller. Photographic documentation only covers this aircraft from the left side and the right side is an estimation.

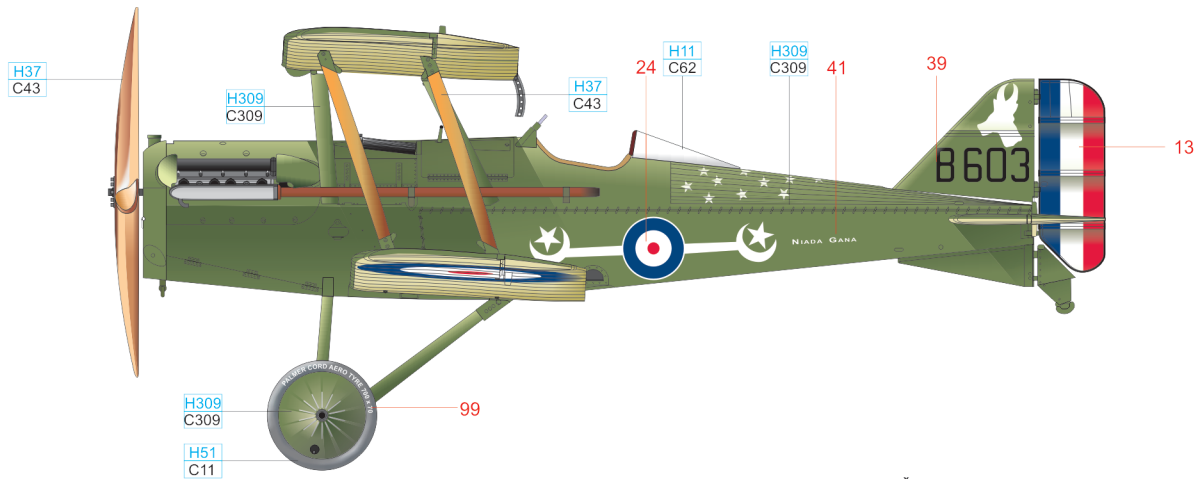

ČESKOU VERZI TEXTU NALEZNETE NA
www.eduard.com/s/R0015

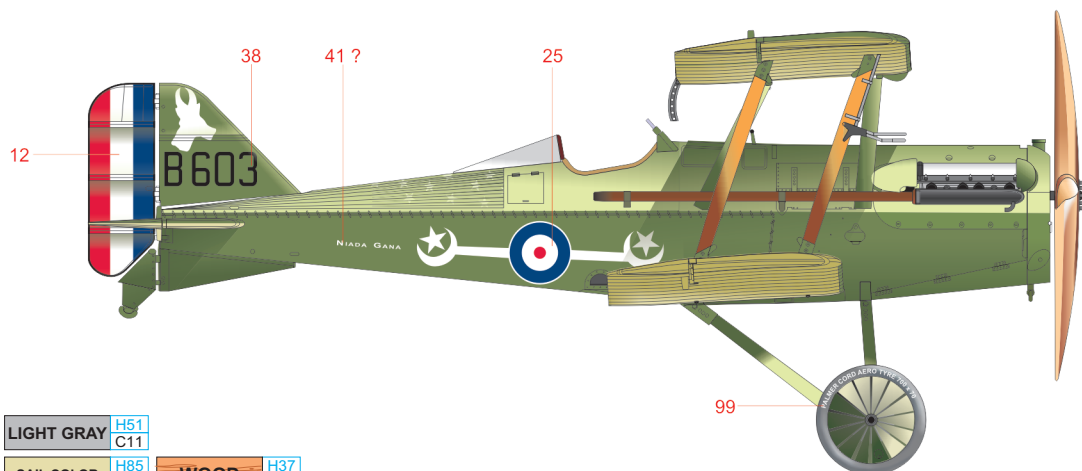
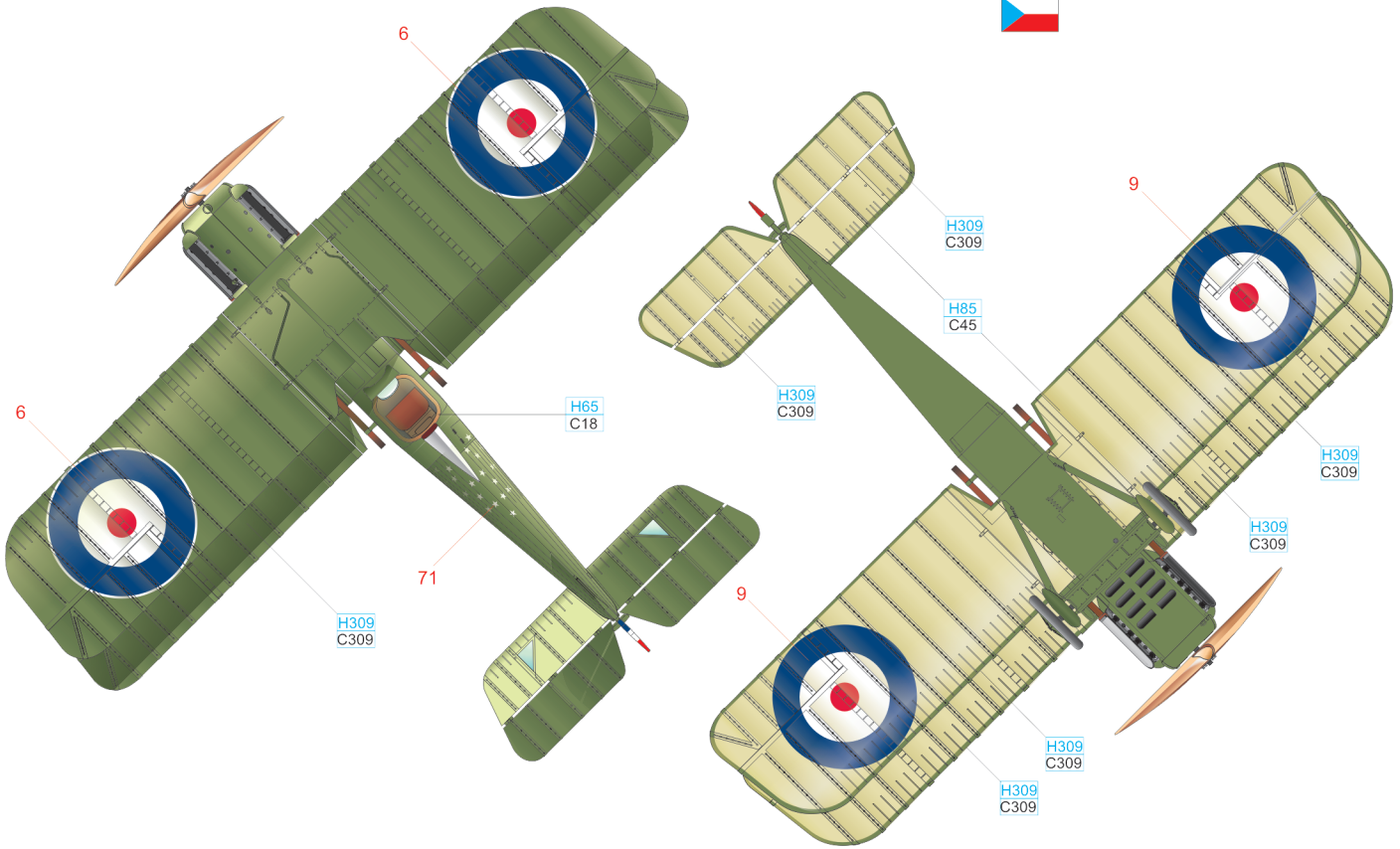

RED BROWN	H47 C41	WHITE	H11 C62	LIGHT GRAY	H51 C11	WOOD	H37 C43
GREEN	H309 C309	SAIL COLOR	H85 C45				

H B525, flown by Lt. A. P. F. Rhys - Davids, No. 56 Squadron, Estrée Blanche, France, October 1917

Arthur Percival Foley Rhys - Davids, a British ace with 27 kills to his credit was born on September 26th, 1897 in south London. In mid-1916, he joined the Royal Flying Corps and underwent pilot training from August 28th. After its completion, he was assigned to No.56 Squadron, which became his sole unit. He left Britain on April 7th, 1917. He developed into an excellent fighter pilot and was one of the pilots that overpowered Werner Voss and his Fokker F.I on September 23rd, 1917. His combat luck would abandon him on November 11th, 1917, when he was last seen east of Roulers tangling with an Albatros fighter... SE.5as of No.56 Squadron carried a wide white stripe on the rear fuselage. From September 1917 until March 1918 they further displayed blue and white segments on the outer surfaces of the wheel hubs.

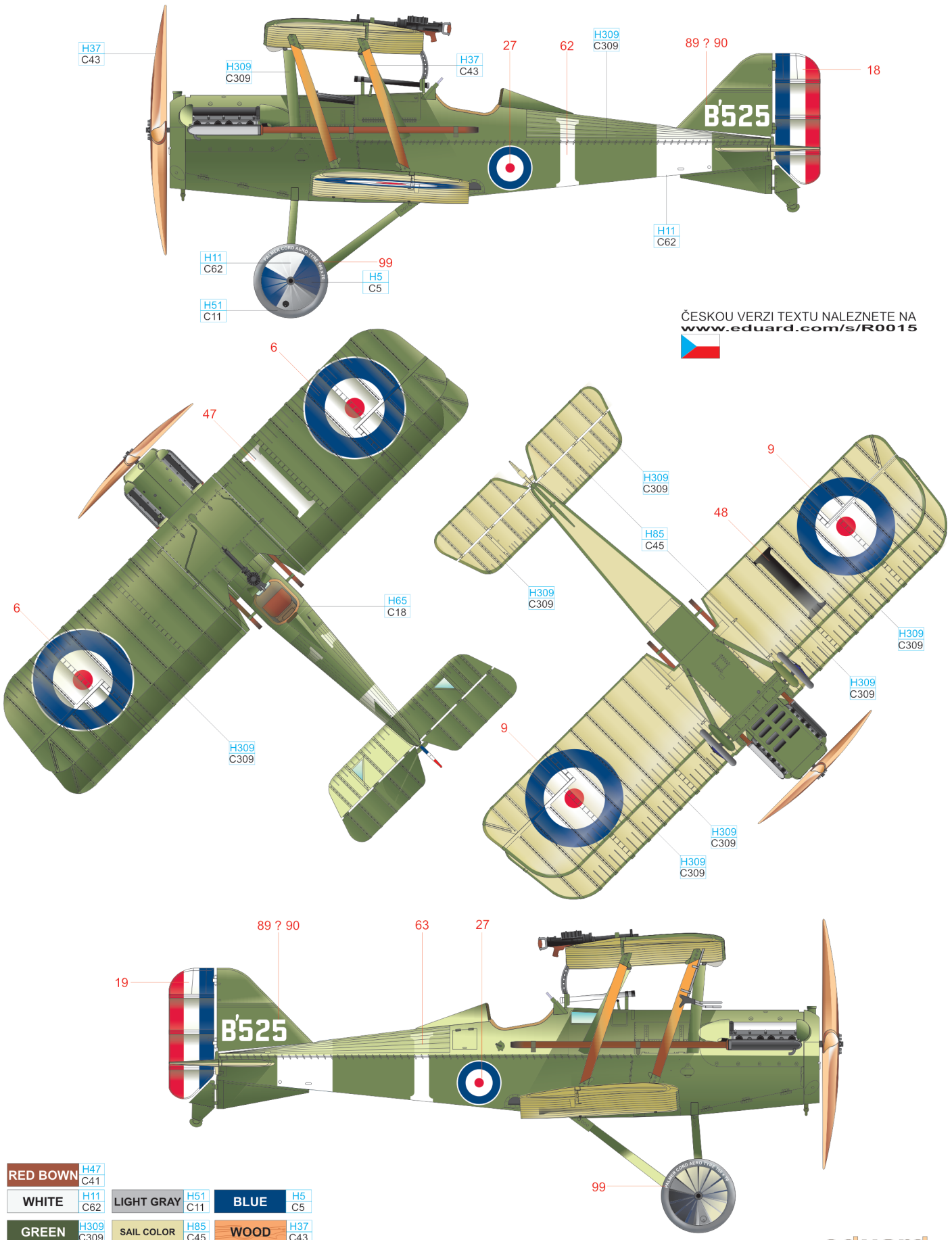

B507, flown by 2/Lt J. J. Fitzgerald, No. 60 Squadron, Sainte-Marie-Cappel, beginning of October 1917

No.60 Squadron was formed on April 30th, 1916 at Gosport and was equipped with Morane Saulnier Type N fighters. After the Battle of Somme, when heavy losses were suffered, the unit was re-equipped with the Nieuport 17 and then with the new British SE.5a in July 1917. Machine B507 served first with No.56 Squadron, where it was flown by Lt. L.M. Barlow who with it shot down several enemy aircraft. On August 22nd, 1917, the aircraft was damaged by 2/Lt. A.P.F. Rhys-Davids. After being repaired, the plane was attached to No.60 Squadron. Engine failure forced 2/Lt. J.J. Fitzgerald to land at a Jasta 18 airfield, making him a prisoner on October 5th, 1917.

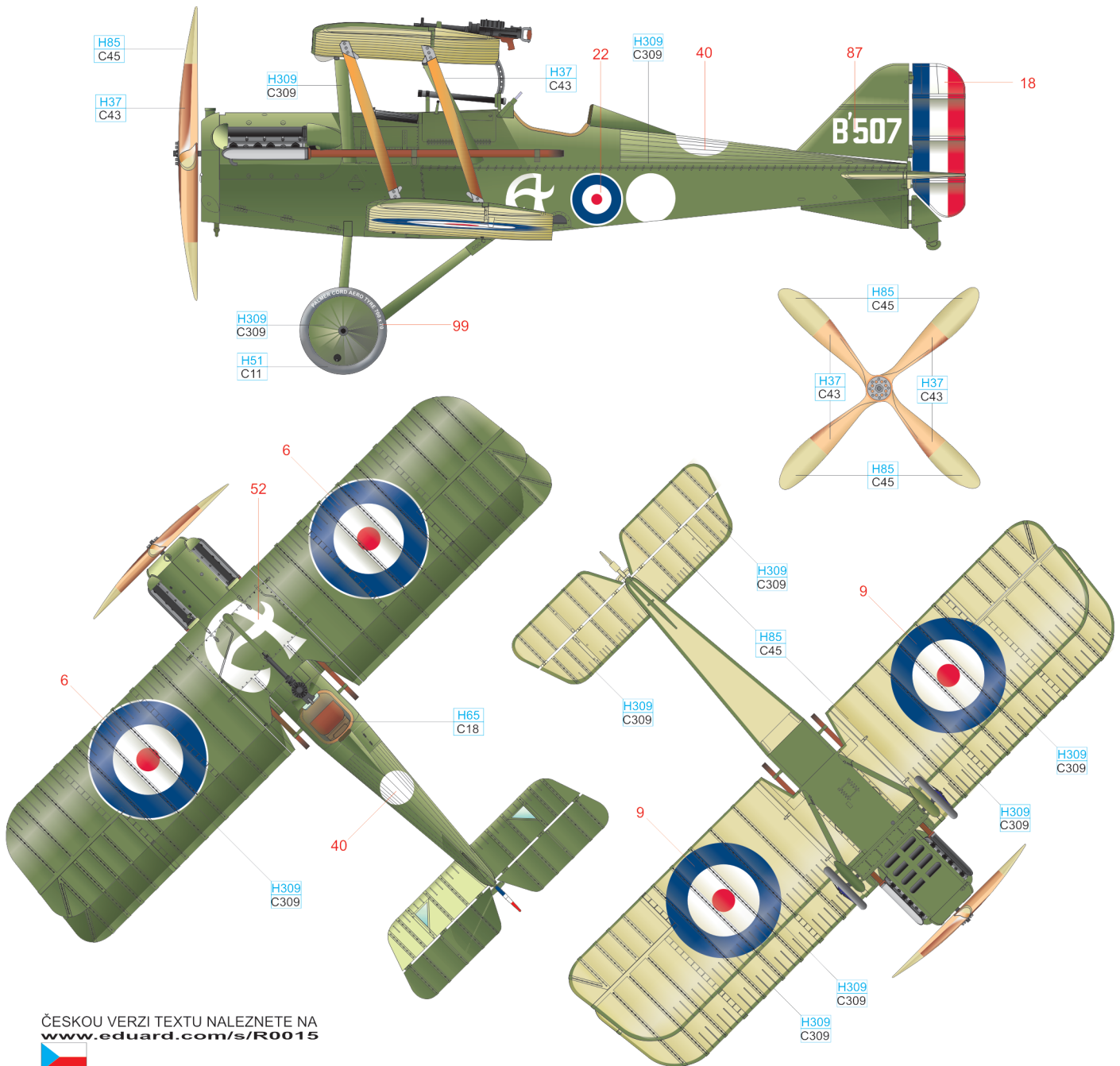

ČESKOU VERZI TEXTU NALEZNETE NA
www.eduard.com/s/R0015



RED BROWN	H47 C41	WOOD	H37 C43
LIGHT GRAY	H51 C11	SAIL COLOR	H85 C45
GREEN	H309 C309		

J F9029, No. 1 Squadron Canadian Air Force, Shoreham, Great Britain, 1919

No.1 Squadron, Canadian Air Force, was formed on November 20th, 1918 at Upper Heyford in Oxfordshire County. On April 1st, 1919, it was located at Shoreham field equipped with the SE.5a and Sopwith Dolphins. Aircraft F9029, No.1 Squadron CAF, was part of a 200 aircraft order that was filled by Vickers. A portion of the order was delivered prior to the end of the war, but most were delivered after. As an identifier of belonging to the CAF, there was a maple leaf on the fin, and the marking on the front of the plane was likely a personal emblem.

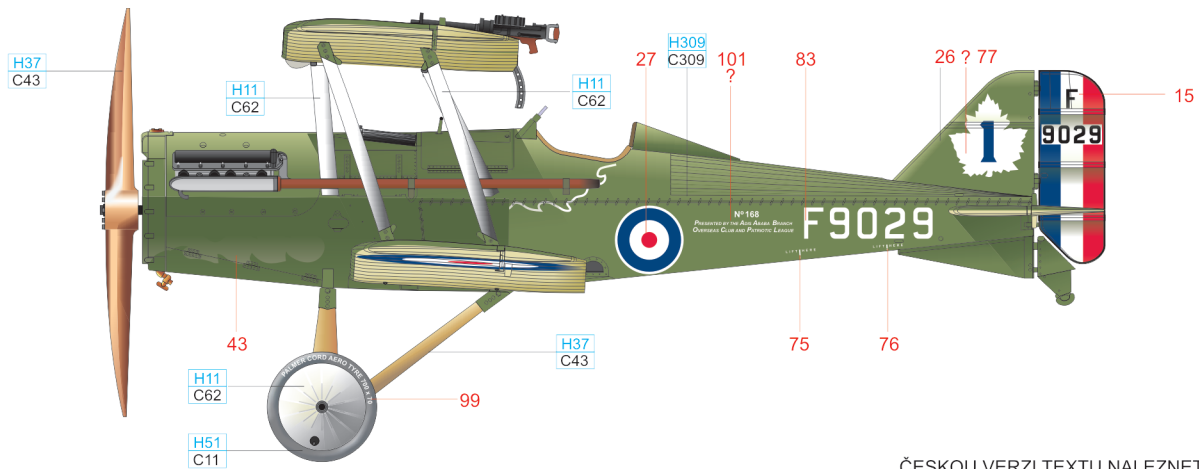

ČESKOU VERZI TEXTU NALEZNETE NA www.eduard.com/s/R0015

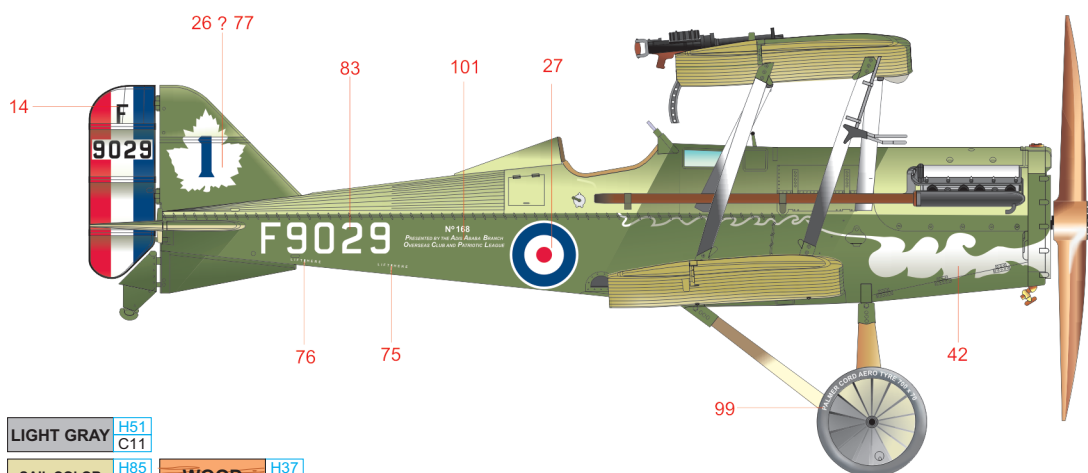
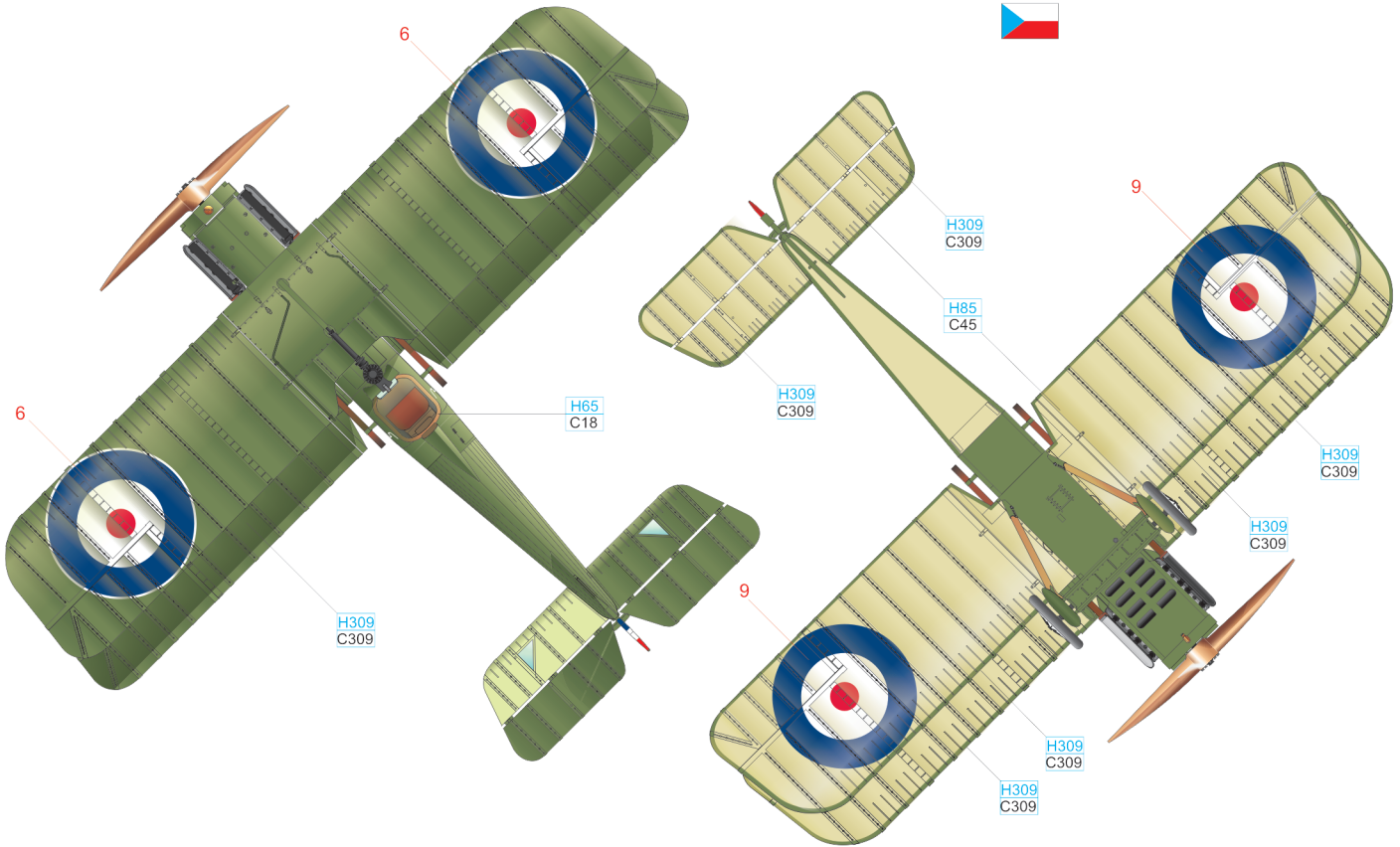

RED BROWN	H47 C41	WHITE	H11 C62	LIGHT GRAY	H51 C11	WOOD	H37 C43
GREEN	H309 C309	SAIL COLOR	H85 C45				

K D362, 5th and 6th Training Squadron, Australian Flying Force, Minchinhampton, Great Britain, 1918/1919

Combat over the front during the First World War was also taken part by Australian pilots. Squadrons 67, 68, 69 and 71, established over 1916, were re-organised as 1 to 4 Squadron, Australian Flying Corps in January and February 1918. Consequently, the 29th and 30th (Australian) Training Squadrons were formed to train new pilots (both in June 1917) along with 32nd and 33rd Training Squadrons (October 1917). These were later redesignated 5th to 8th Training Squadrons, Australian Flying Corps. 5th and 6th Training Squadron, Australian Flying Corps flew out of Minchinhampton in Gloucestershire County. The white kangaroo naturally indicated nationality.

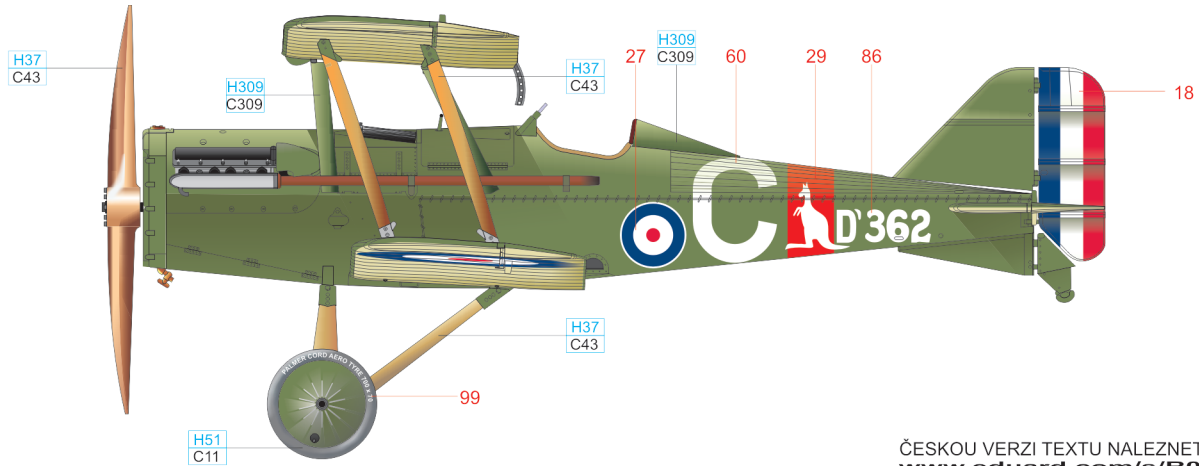

ČESKOU VERZI TEXTU NALEZNETE NA www.eduard.com/s/R0015

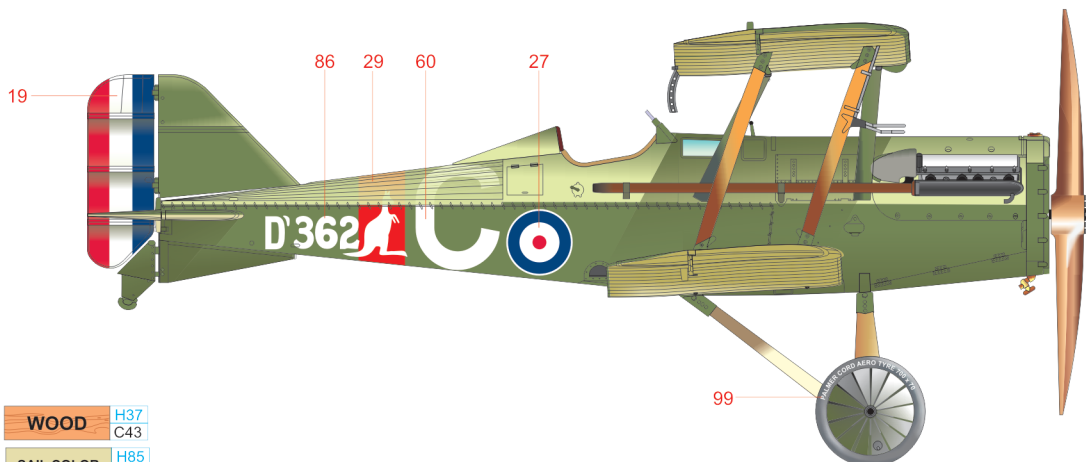
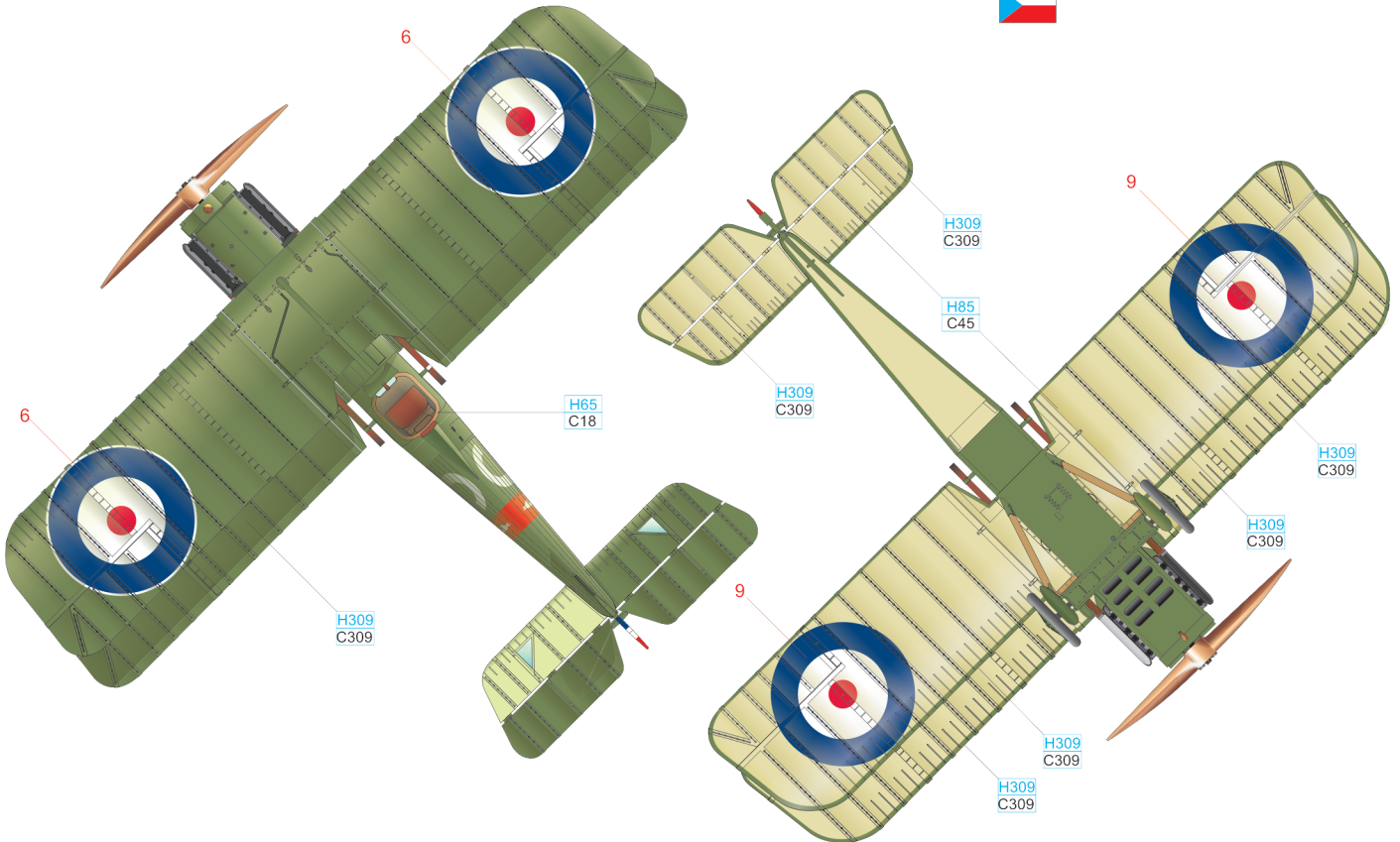

RED BROWN	H47 C41	WOOD	H37 C43
LIGHT GRAY	H51 C11	SAIL COLOR	H85 C45
GREEN	H309 C309		

A2-24, flown by F/O F. C. Even, No. 3 Squadron Australian Air Force, Canberra, Australia, beginning of May 1927

On June 4th, 1919, Australia was gifted aircraft from Great Britain, among them being thirty-five new machines from British stocks. After their arrival in Australia, they were first stored in wheel sheds at Spotswood near Melbourne. After the formation of the Australian Air Force on March 31st, 1921, they became the first aircraft used by the service. They were marked A2-1 to A2-35. SE.5a A2-24 (originally coded C8995) was in storage till 1926. After that, it first served with No.1, and subsequently No.3, Squadrons. On May 9th, 1927, during a ceremonial parade commemorating the opening of a new federal parliament house, the airplane crashed with F/O F.C. Even flying it. He did not survive.

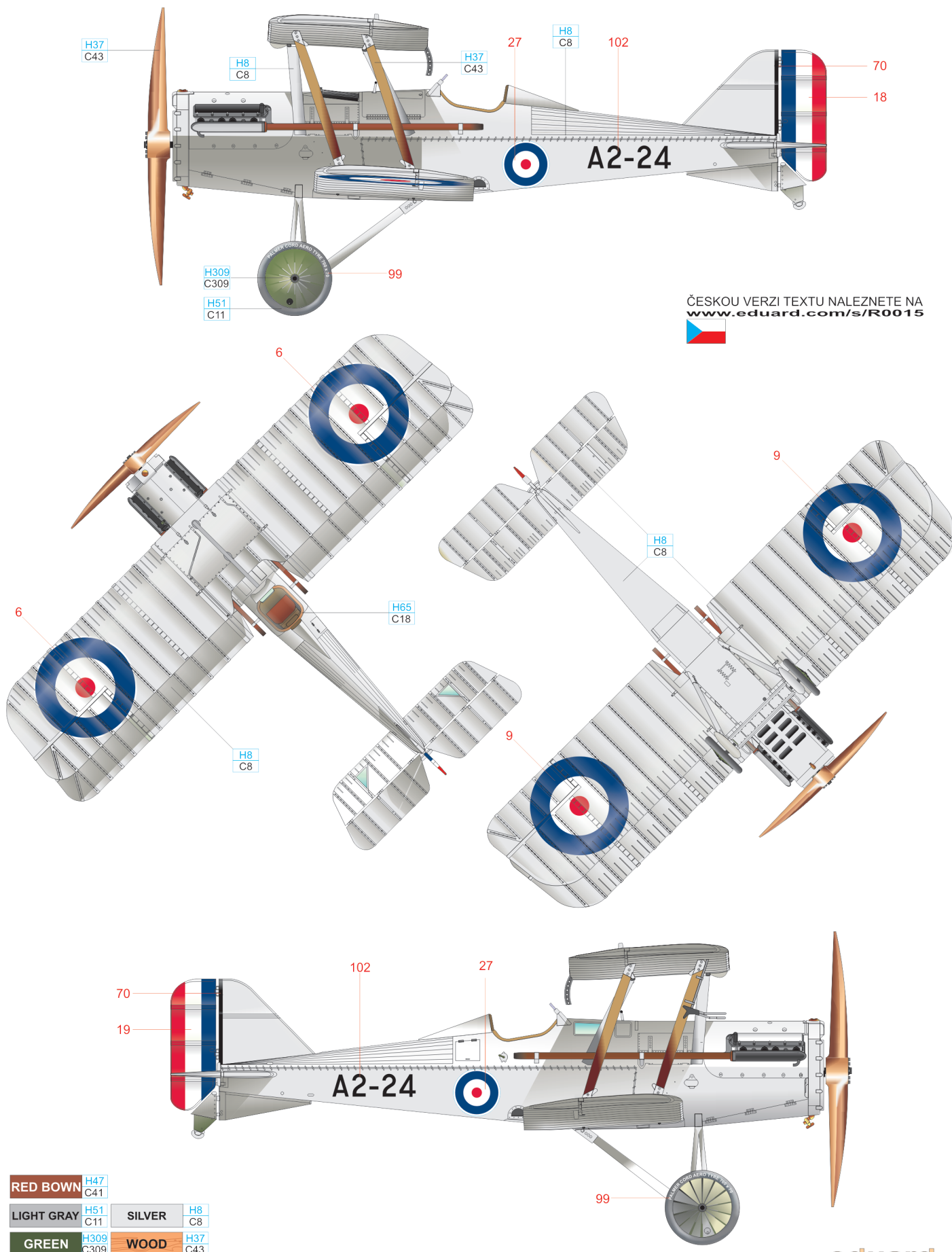

M F8005, flown by Capt. R. G. Landis, CO of 25th Aero Squadron, Collombey-les-Belles, France, November 1918

The history of the 25th Aero Squadron began to be written on May 7th, 1917 at Kelly Field in Texas. In January 1918, it crossed the Atlantic and underwent training in Great Britain. On its completion, the unit was moved to France and was equipped with SE.5as. On November 10th, 1918, it took part in flights over the front lines for the first time. In June of the following year, the unit was disbanded at Mitchel Field, New York. Capt. Reed G. Landis, a former No.40 Squadron, RFC pilot, was named CO of the 25th Aero Squadron in August 1918. The emblem of the 25th Aero Squadron was an executioner dressed in black, wearing a mask and wielding a large axe. Landis's aircraft additionally carried the unit CO's marking, a red diamond on the fin and two white ones on the upper fuselage.

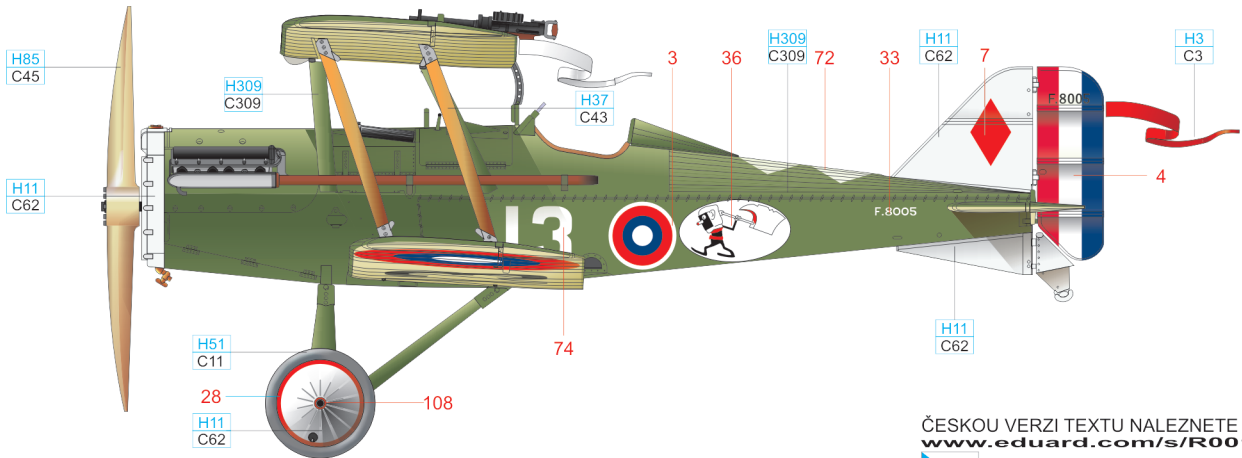

ČESKOU VERZI TEXTU NALEZNETE NA www.eduard.com/s/R0015

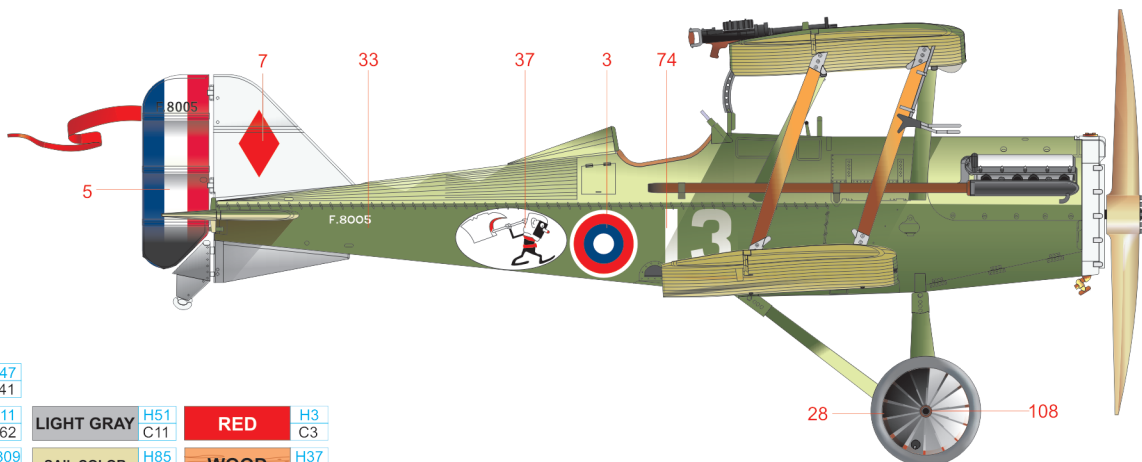
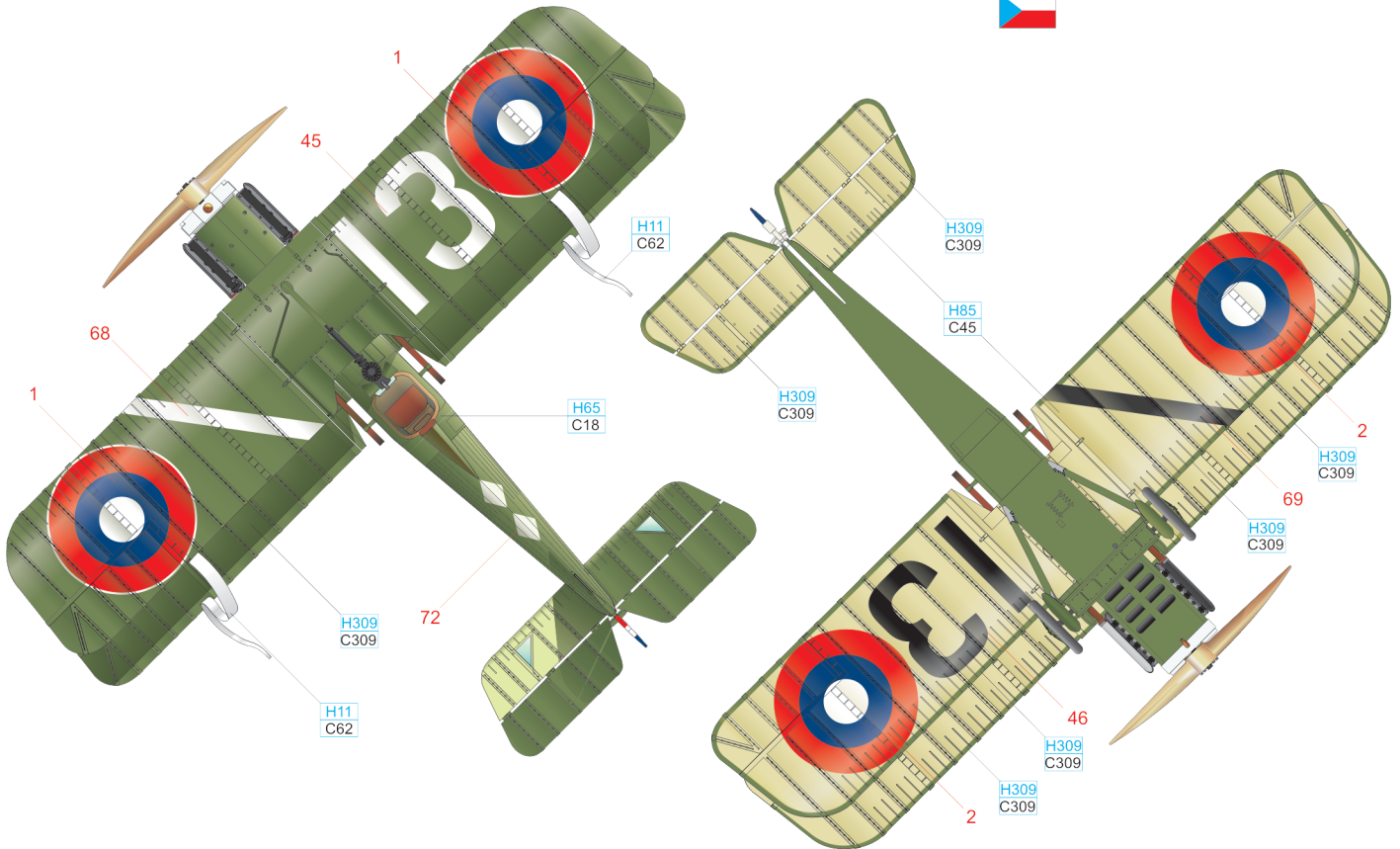

RED BROWN	H47 C41	WHITE	H11 C62	LIGHT GRAY	H51 C11	RED	H3 C3
GREEN	H309 C309	SAIL COLOR	H85 C45	WOOD	H37 C43		