



He 111H-3

Германский бомбардировщик II MB

В начале 30-х годов в мире возникла идея создания скоростного бомбардировщика, который мог бы обогнать современные ему истребители-бипланы. Одним из воплощений этой концепции стал двухмоторный бомбардировщик He 111, разработанный германской фирмой Хейнкель Флюгцугверке.

С ноября 1940 г. началось производство самолетов He 111H-3 с усиленным вооружением, на которых были установлены двигатели жидкостного охлаждения Jumo 211D-1 увеличенной мощности.

В начале 1940 г. было построено 504 бомбардировщика He 111H-3. Они принимали участие во всех операциях Люфтваффе в 1940-1941 г.

Тактико-технические характеристики He 111H-3

Длина, м	16,38
Размах крыла, м	22,50
Взлетный вес, кг	13300
Двигатели	2xJumo 211D-1, 1200 л.с.
Максимальная скорость, км/ч	430
Потолок, м	8000
Дальность, км	2000
Вооружение	1-2x20-мм пушки MG FF, 4-7x7,92-мм пулеметов MG 15, до 2000 кг бомб

ВНИМАНИЕ!

Перед сборкой внимательно прочитать руководство по монтажу. Каждая деталь пронумерована. Соблюдать последовательность монтажа. Проверить наличие инструкций: ножи и напильники для зачистки деталей; резиновая лента, клейкая лента и зажимы для сушки белила для прижатия склеиваемых деталей. Детали из пластика очистить в растворе из этого мощного средства и высушить на воздухе для того, чтобы краска и переводные картинки лучше прилипали. Перед приклеиванием проверить, подходят ли детали; клей наносится экономно. Узор и краску удалить с поверхностей склеивания. Небольшие детали покрывать перед тем, как они будут удалены из рамок. Краску необходимо хорошо просушить, только после этого продолжать сборку. Каждую соответствующую переводную картинку отдельно вырезать и примерно на 20 секунд окунуть в теплую воду. На обозначенном месте картинку отделить от бумаги и прижать промокающей бумагой.

He 111H-3

WWII German Bomber

In the beginning of 30s it was appeared in the world an idea of high-speed bomber that could outstrip contemporary fighters. One of the objectifications of this conception became the twin-engine bomber He 111 designed by a German Heinkel Flugzeugwerke AG company.

Since the November of 1939 it were produced He 111H-3 planes with liquid-cooled Jumo 211D-1 engines of increased power and more powerful armament.

In early 1940 it were produced 504 He 111H-3 bombers. They took part in all 1940-1941 Luftwaffe operations.

Tactical and Technical Specifications of He 111H-3

Length, m	16,38
Span, m	22,50
Start weight, kg	13300
Engines	2xJumo 211D-1, 1200 hp
Max. Speed, km/h	430
Service ceiling, m	8000
Range, km	2000
Armament	1-2x20 mm MG FF, 4-7x7,92 mm MG 15, bomb load - up to 2000 kg

CAUTION!

Read the instructions thoroughly prior to assembly. Each component is numbered. Adhere to specified sequence of assembly. Tools required: knife and file for removal of components from frame; rubber bond, adhesive tape and clothes pegs for clamping components together after applying adhesive. Clean plastic components in a mild detergent solution and allow to air-dry so that paint and transfers adhere better. Prior to applying adhesive, check to see whether the components fit together; apply adhesive sparingly. Remove chrome and paint from the contact surfaces. Paint small components before removing them from the frame. Allow paint to dry well, and only then continue to assemble. Cut out each transfer individually and immerse in warm water for approx. 20 seconds. Slide transfer off paper and into designated position, then press on with blotting paper.

ИСПОЛЬЗУЕМЫЕ КРАСКИ / USED COLORS:

	Revell	Tamiya		
A	108	XF1	Черный, матовый	Flat Black
B	105	XF2	Белый, матовый	Flat White
C	115	XF3	Желтый, матовый	Flat Yellow
D	140	XF27	Черно-зеленый RLM 70	Schwarzgrun RLM70
E	139	XF61	Темно-зеленый RLM71	Dunkelgrun RLM71
F	149	XF23	Голубой RLM65	Hellblau RLM65
G	177	XF84	Черно-серый, матовый	Schwarzgrau RLM66
H	145	XF22	Серо-зеленый RLM02	Grau RLM02

	Revell	Tamiya		
J	199	XF16	Алюминий, полуматовый	Aluminium
K	191	X11	Сталь	Steel
L	109	X10	Темный металл	Gun Metal
M	183	XF64	Ржавчина	Rust
N	731	X27	Красный, прозрачный	Clear Red
P	161	X25	Зеленый, прозрачный	Clear Green
Q	156	XF8	Синий, матовый	Flat Blue
R	330	XF7	Красный, матовый	Flat Red

01 СТАДИЯ СБОРКИ
ASSEMBLY STEP

03 СБОРОЧНАЯ ЕДИНИЦА
ASSEMBLY UNIT

A ИСПОЛЬЗУЕМАЯ КРАСКА
USED COLOR

ПРОСВЕРЛИТЬ
OPEN HOLE

НЕ КЛЕИТЬ
DO NOT CEMENT

x2 СДЕЛАТЬ ДВЕ ДЕТАЛИ
MAKE 2 PCS

СДЕЛАТЬ САМОМУ
SCRATCH BUILD

? ПРОИЗВОЛЬНЫЙ ВЫБОР
OPTIONAL

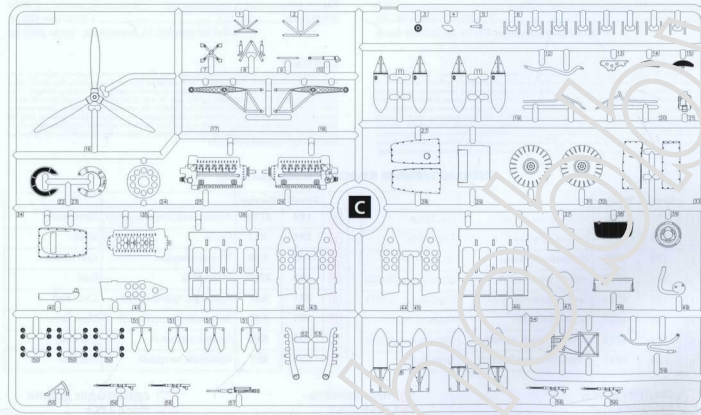
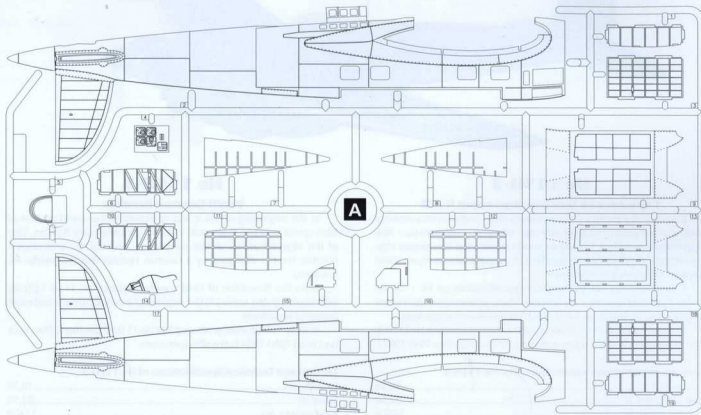

K2

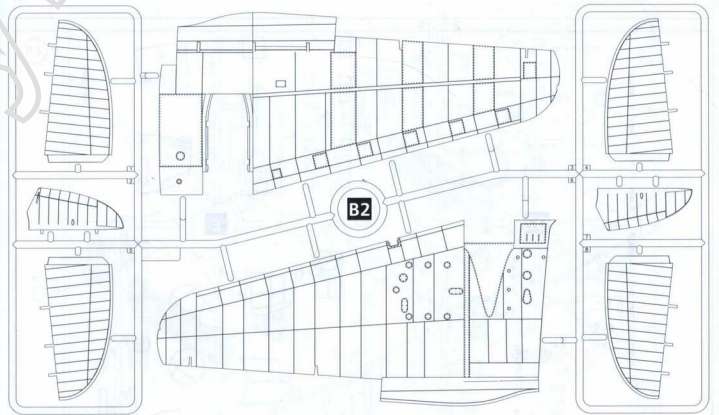
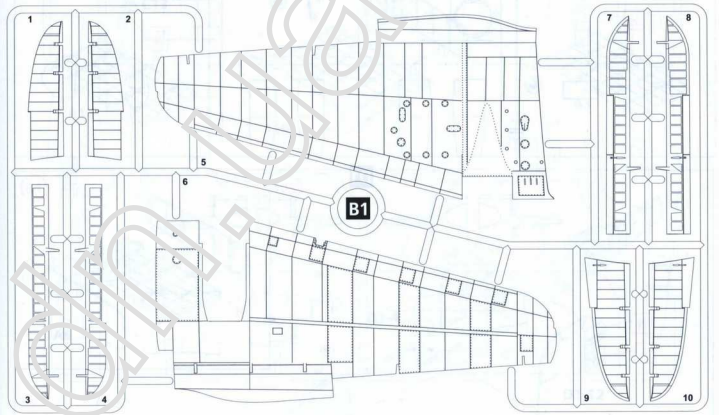

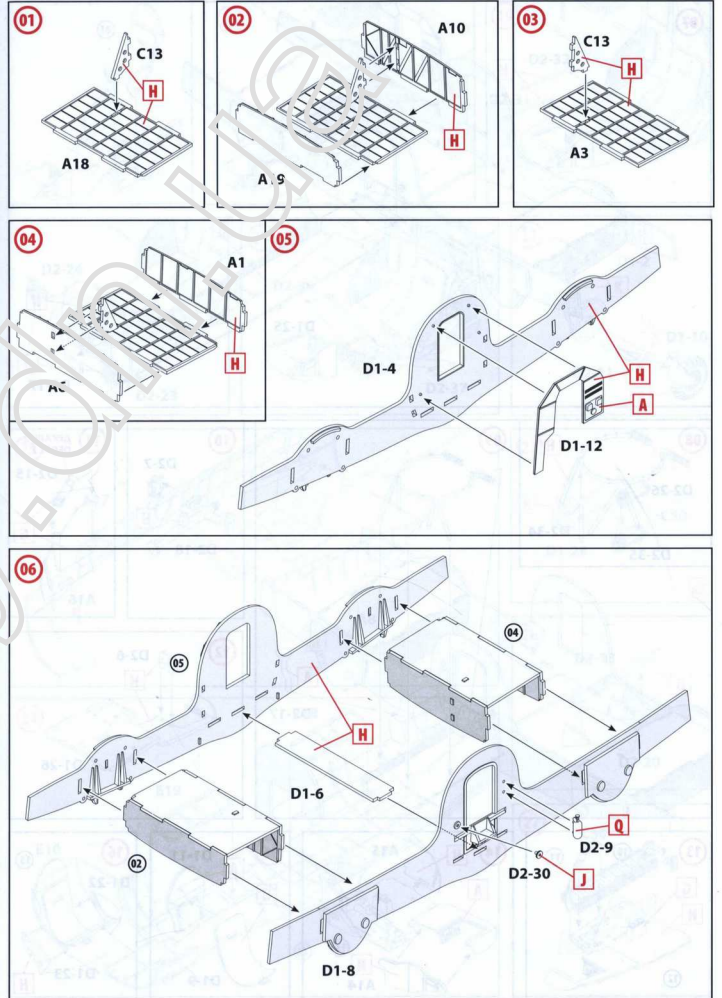
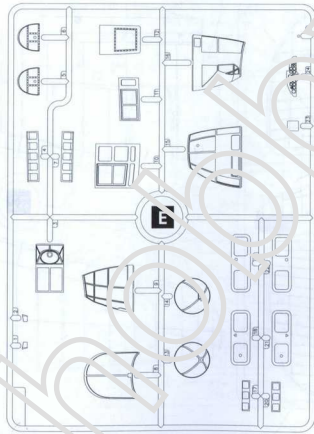
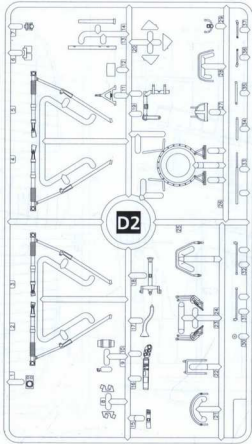
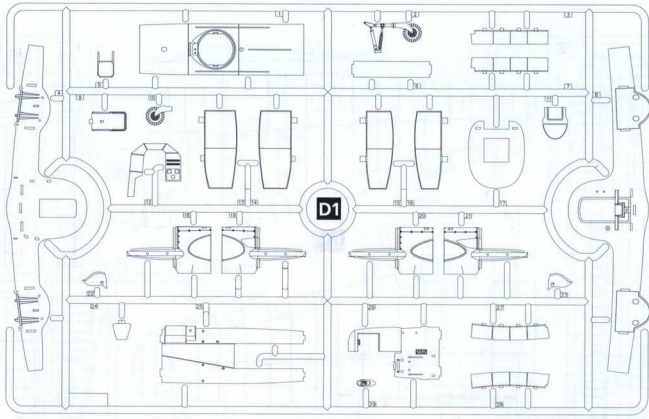

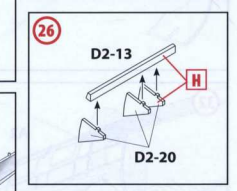
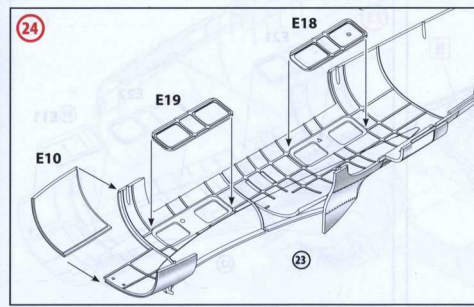
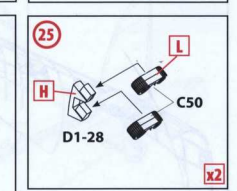
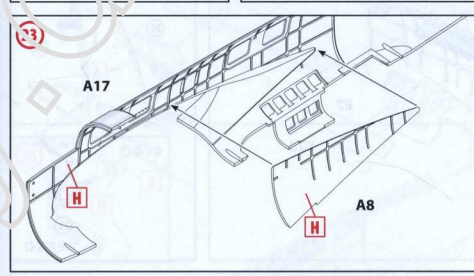
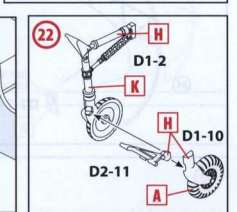
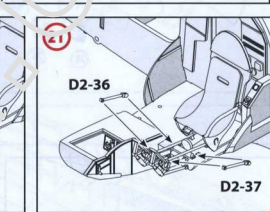
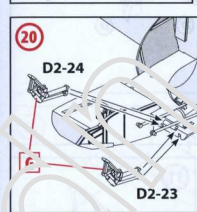
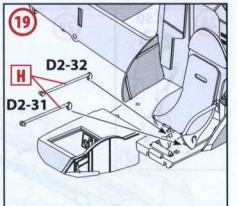
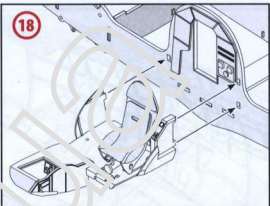
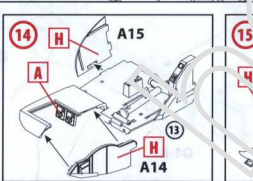
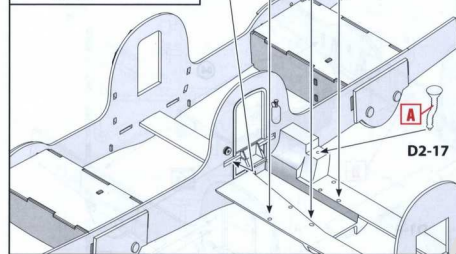
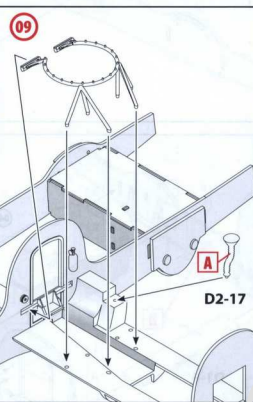
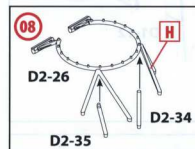
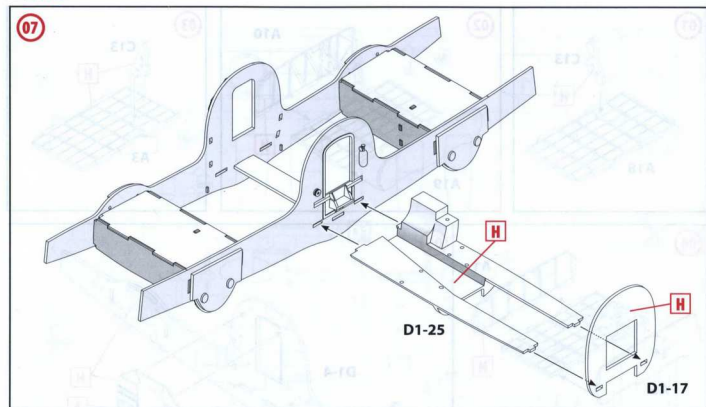

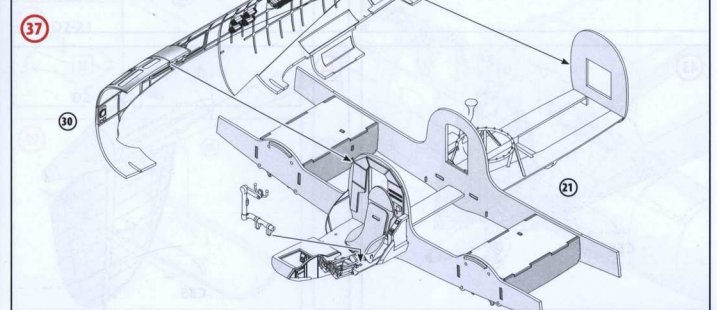
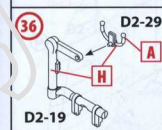
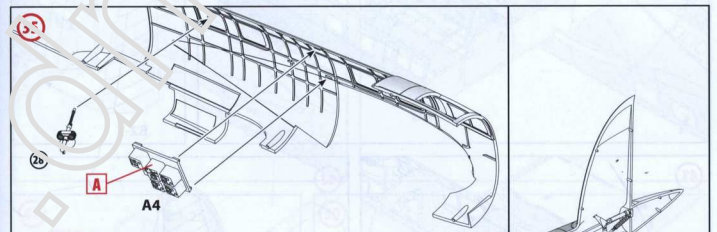
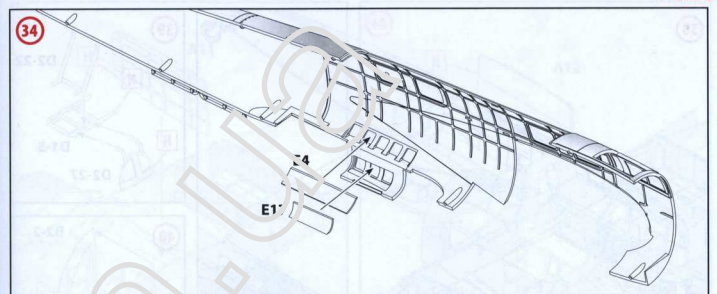
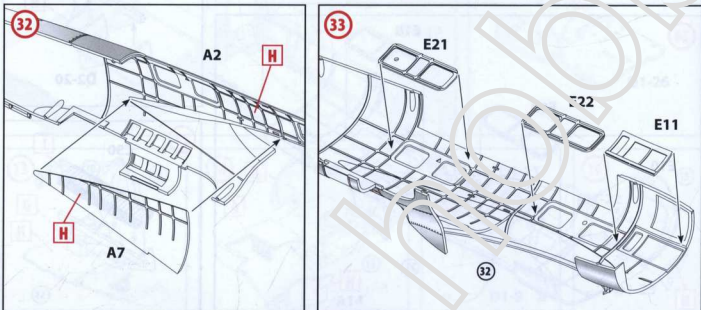
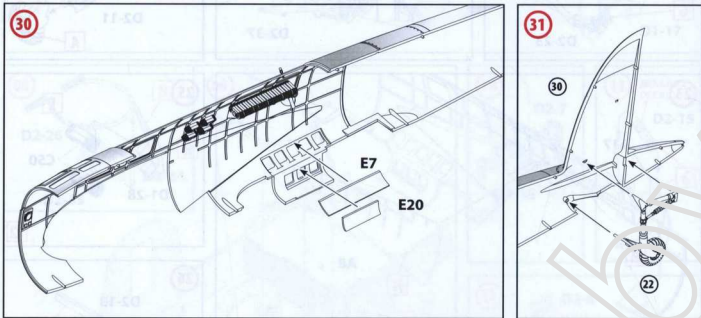
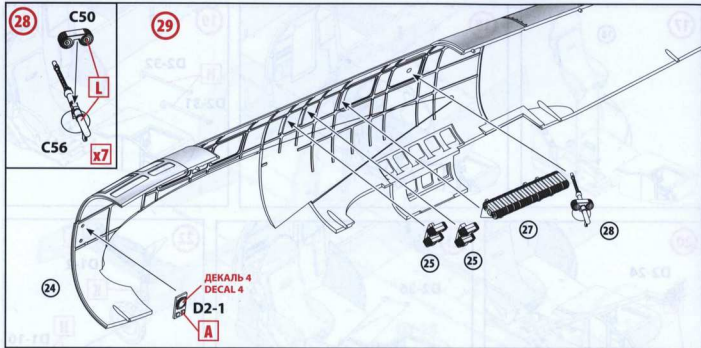

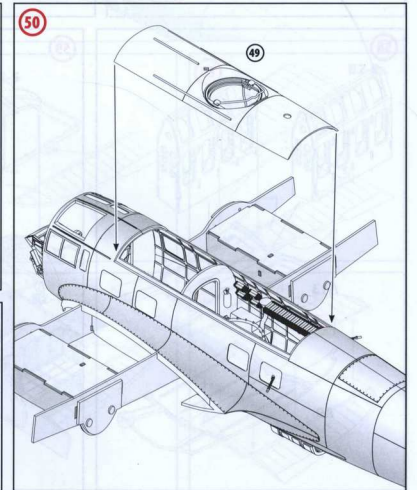
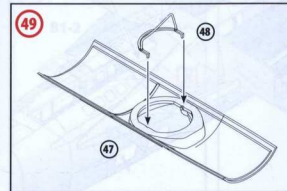
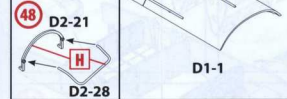
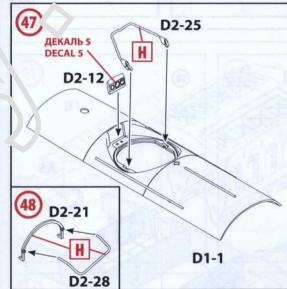
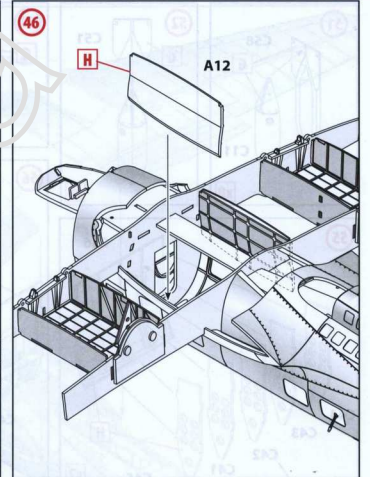
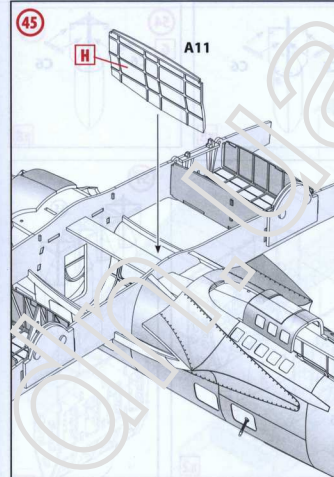
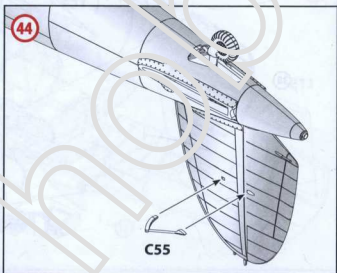
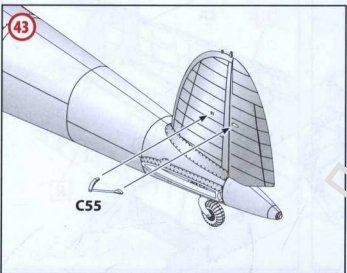
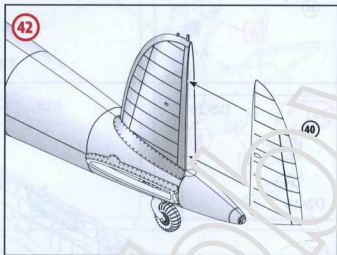
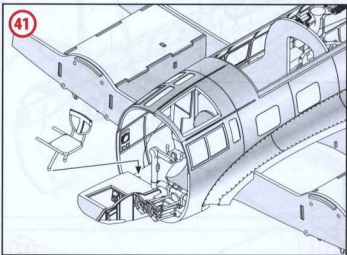
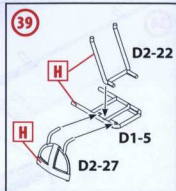
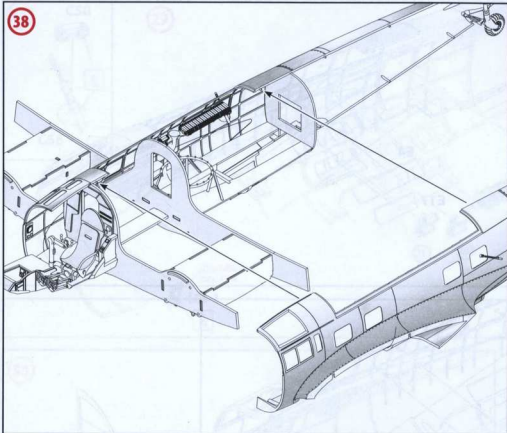

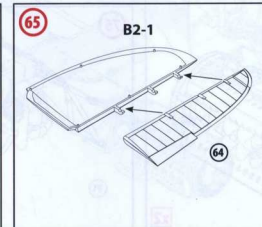
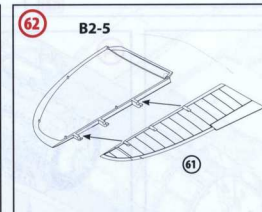
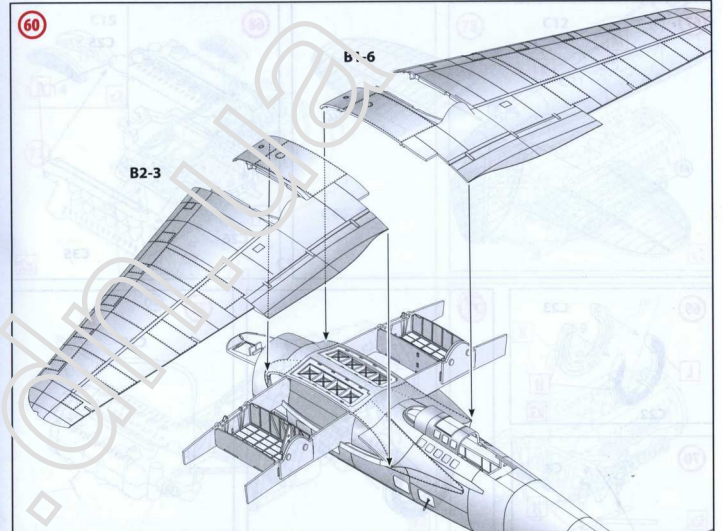
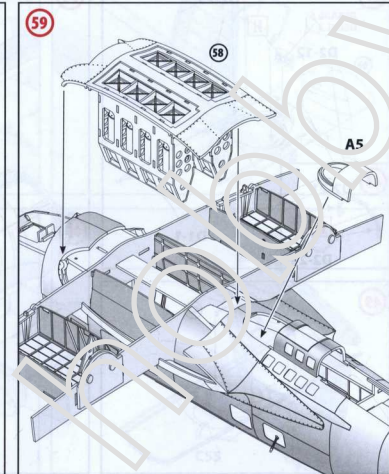
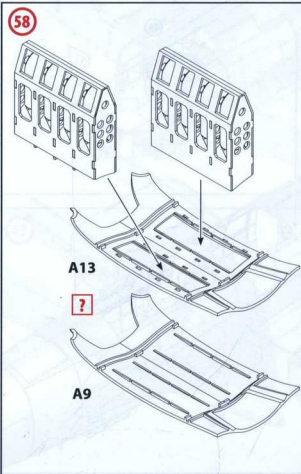
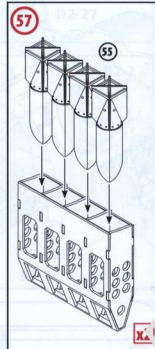
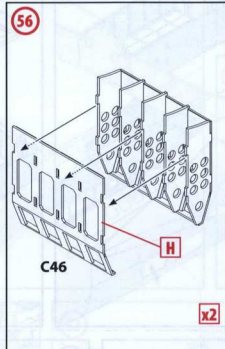
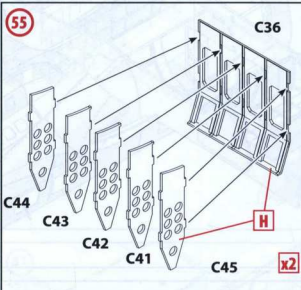
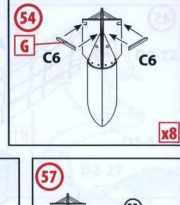
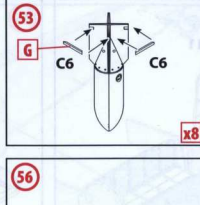
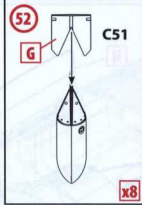
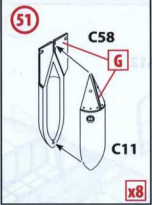

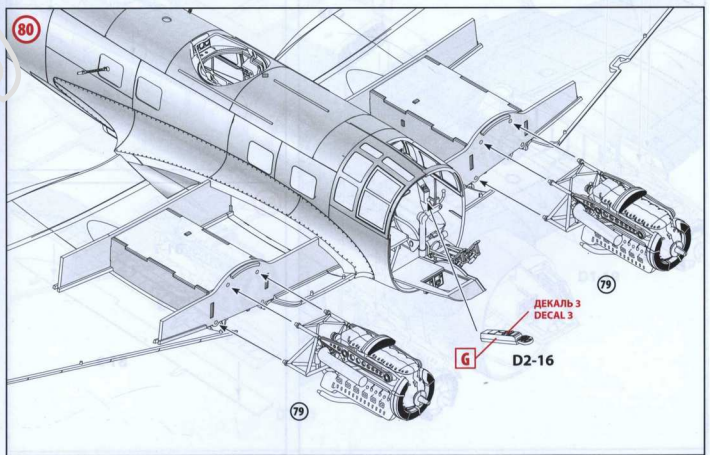
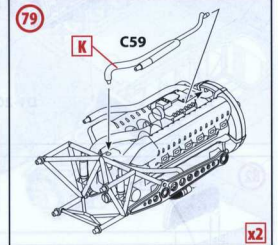
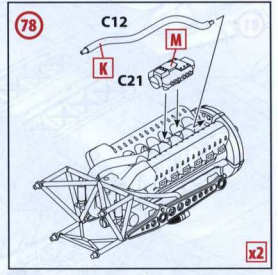
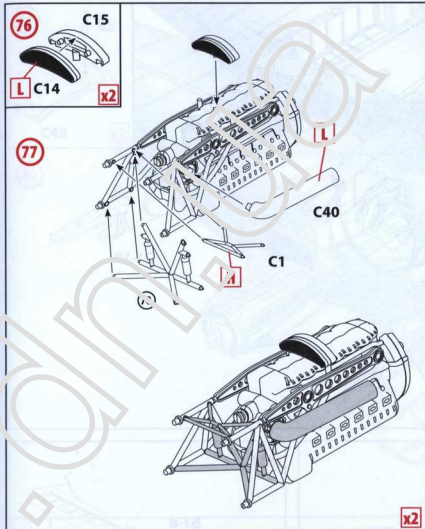
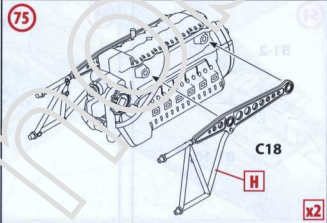
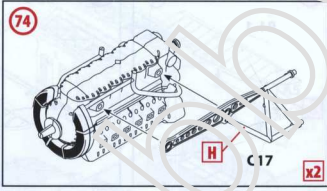
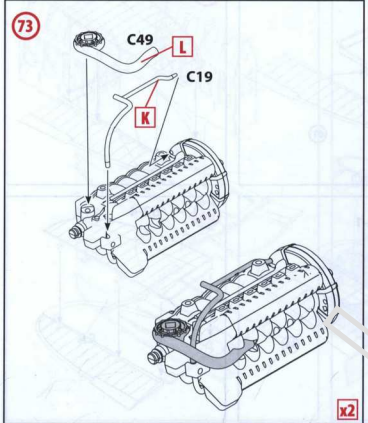
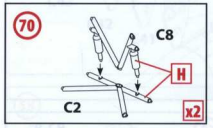
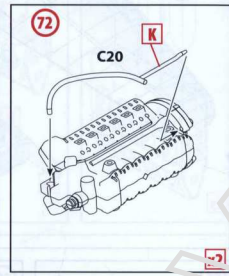
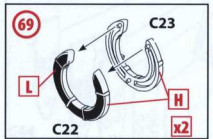
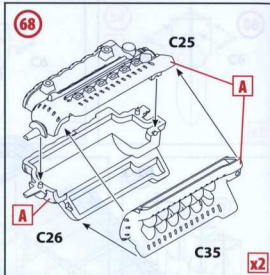
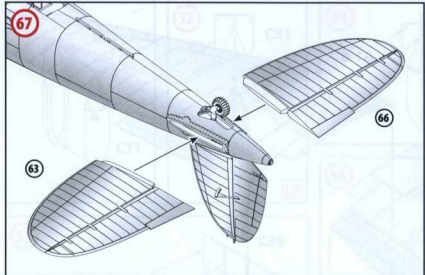

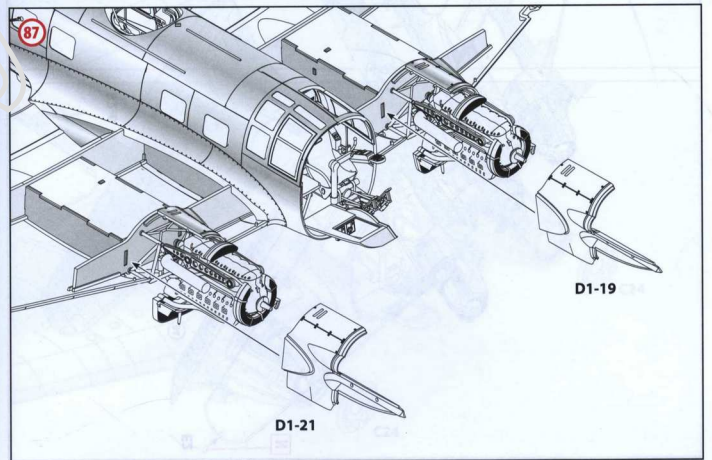
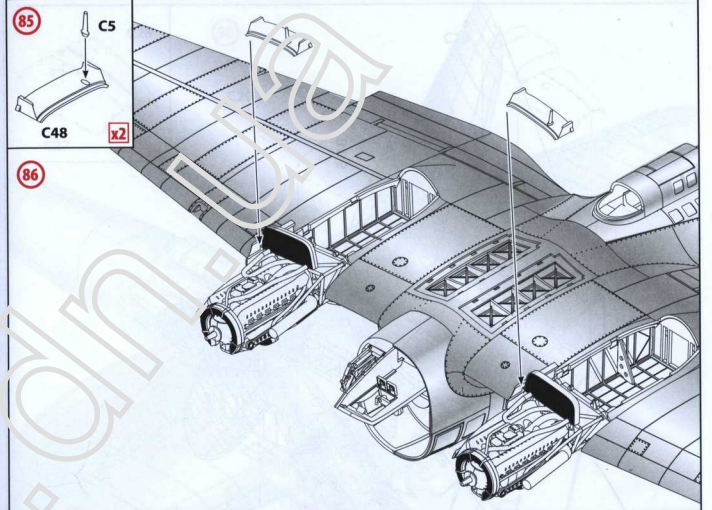
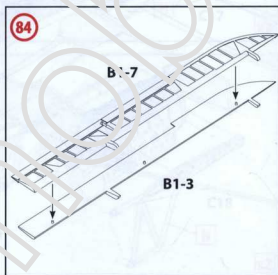
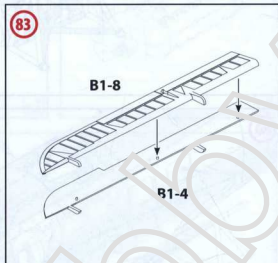
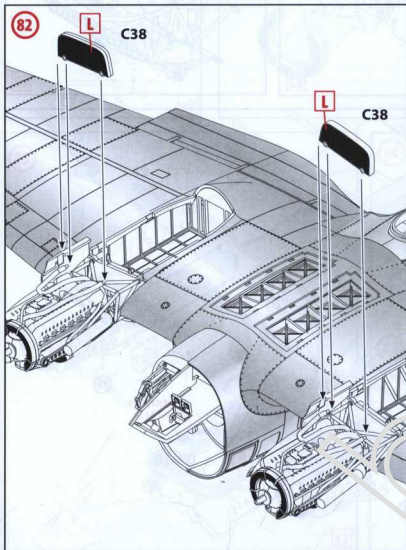
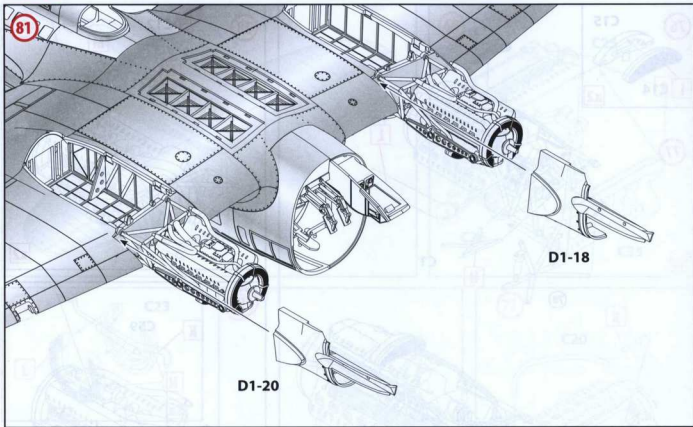

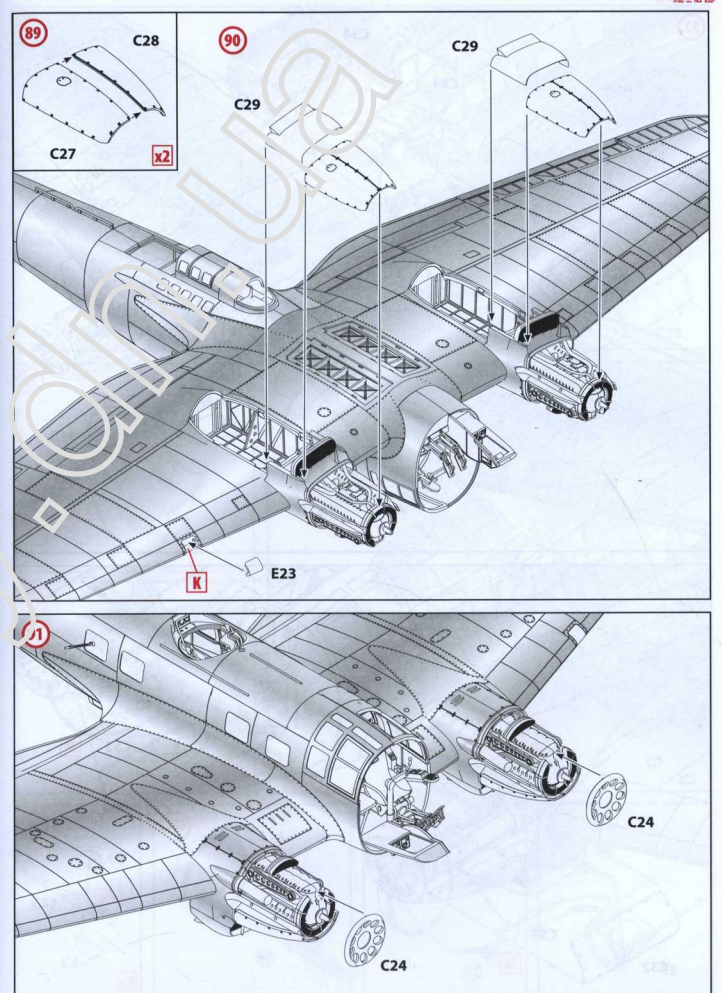
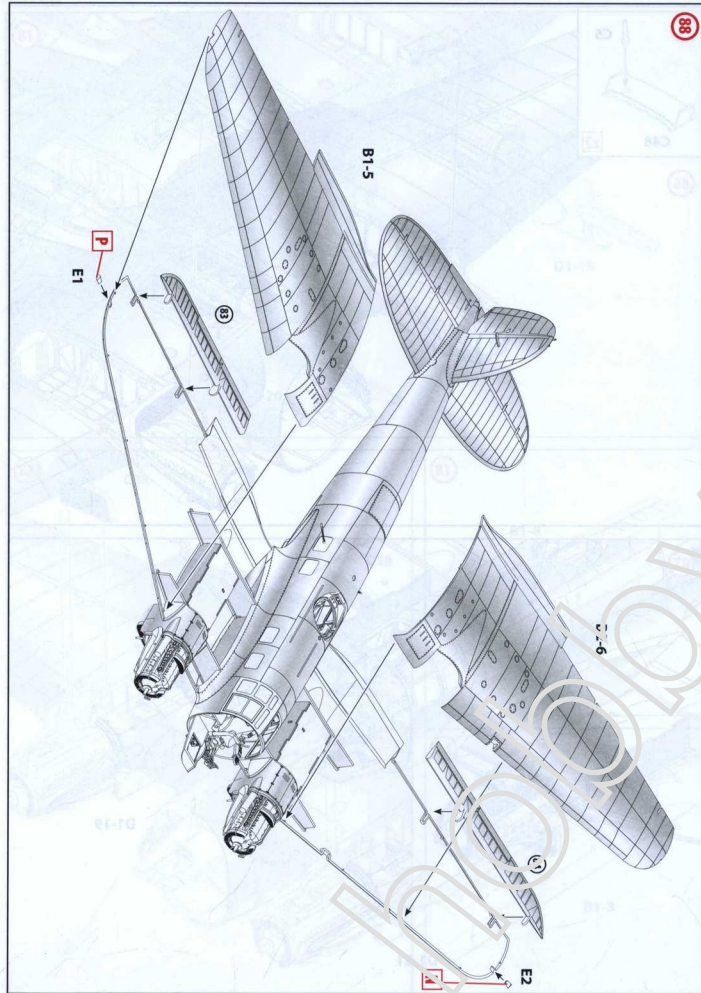

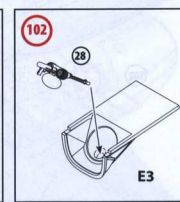
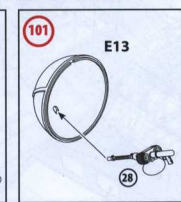
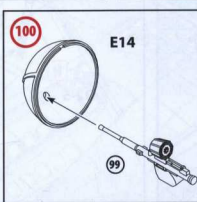
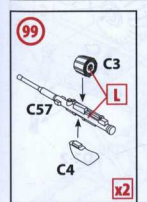
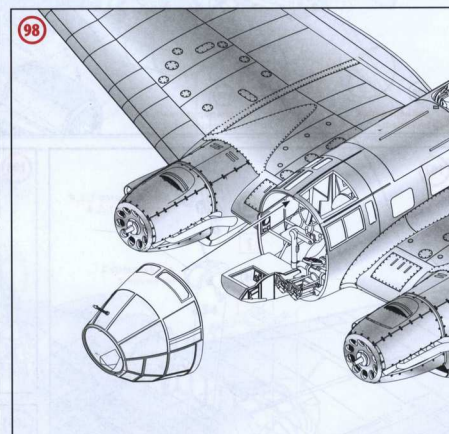
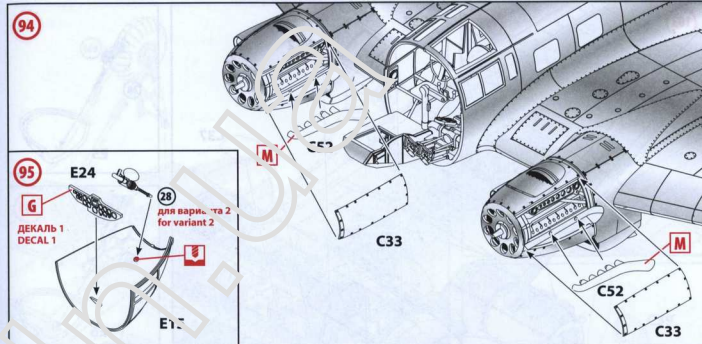
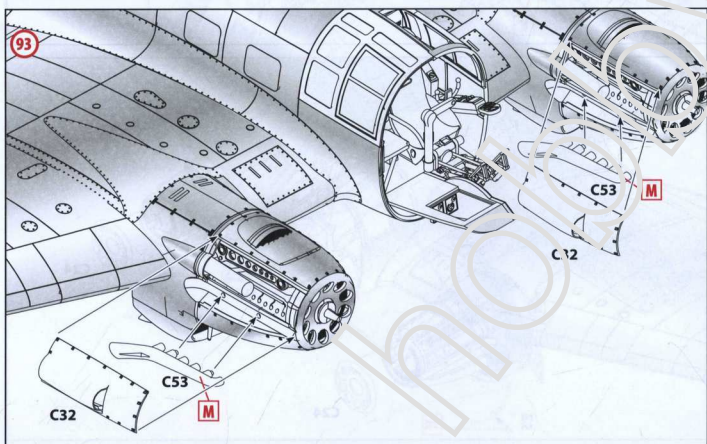
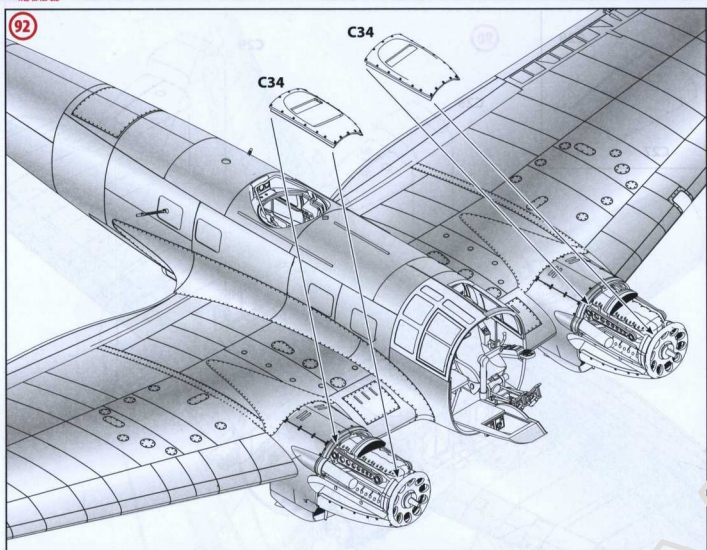

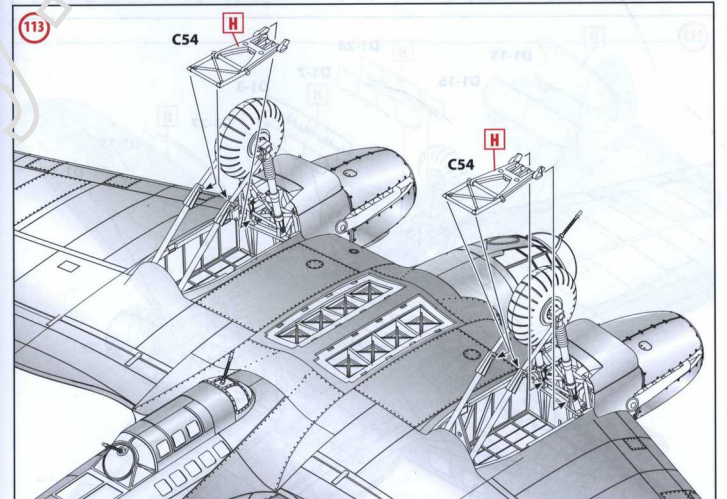
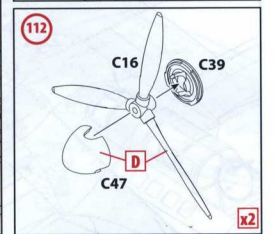
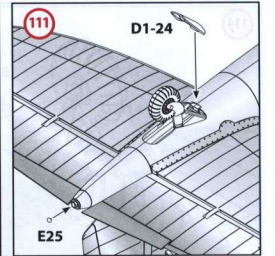
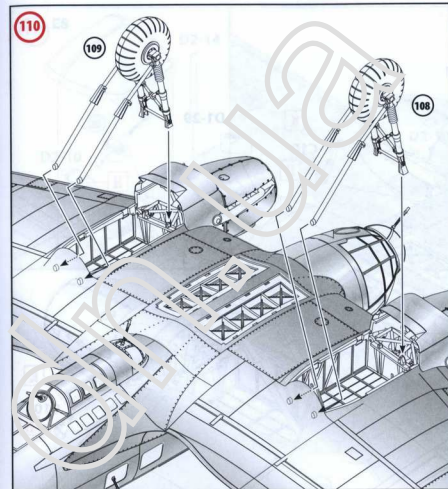
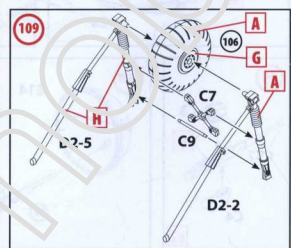
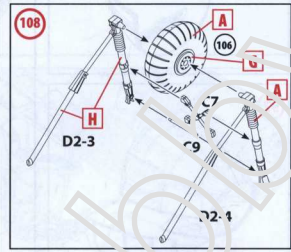
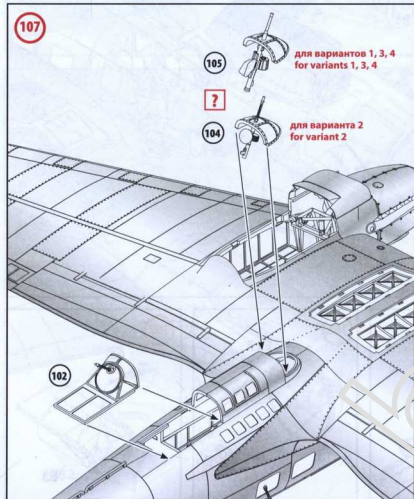
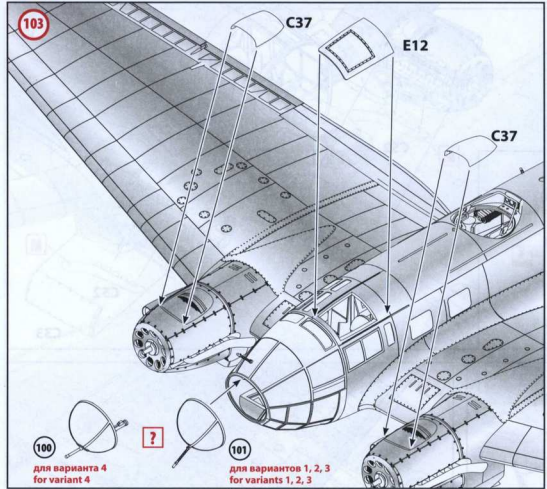

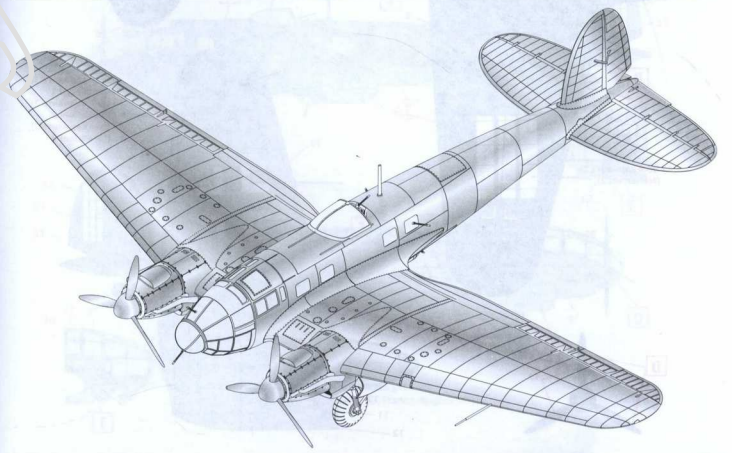
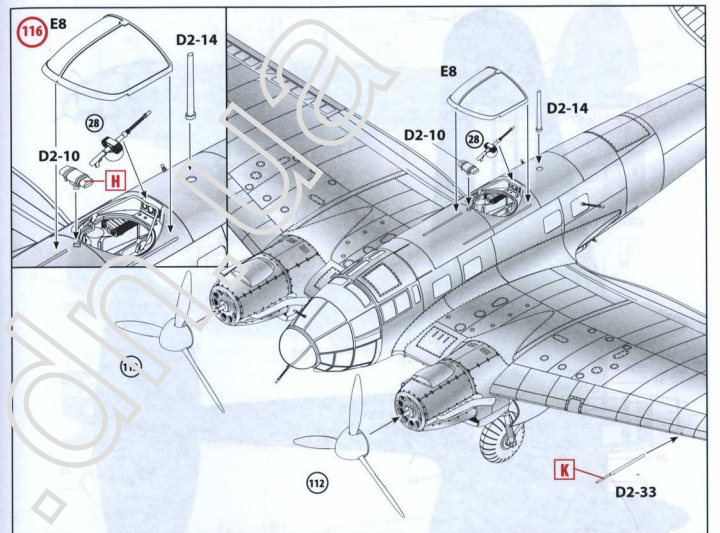
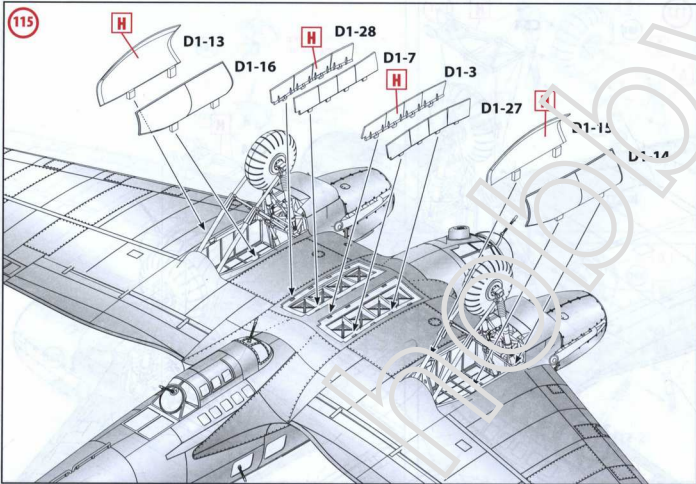
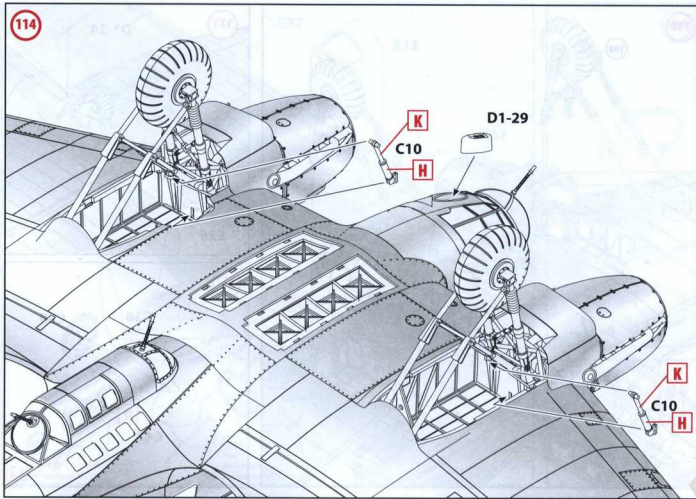

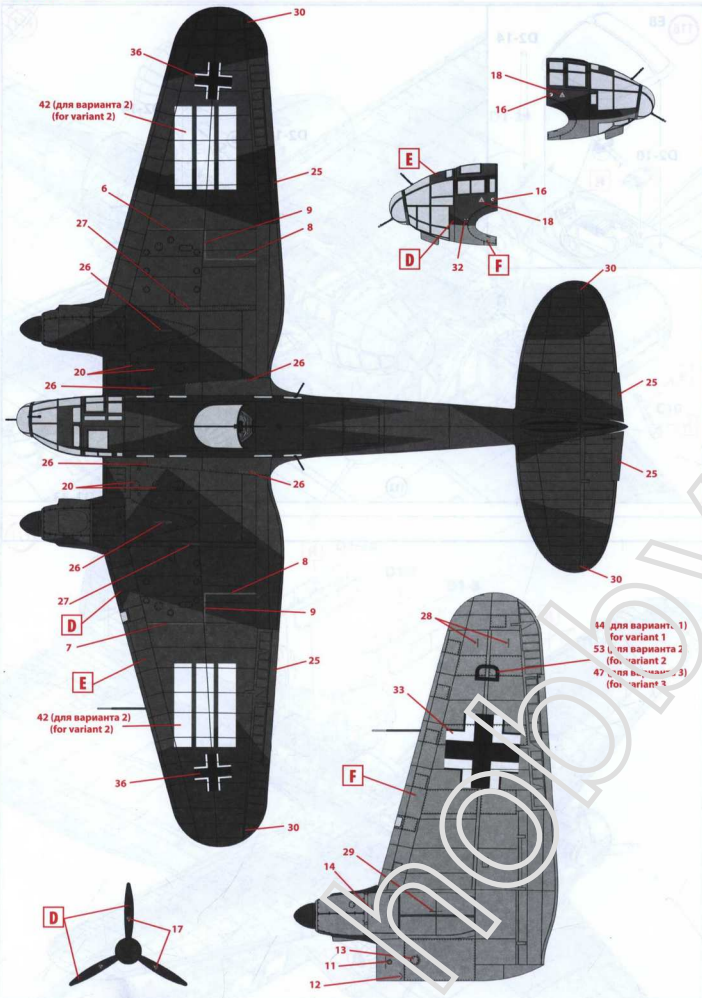

44 для варианта 1) for variant 1
 53 (для варианта 2) (for variant 2)
 47 (для варианта 3) (for variant 3)

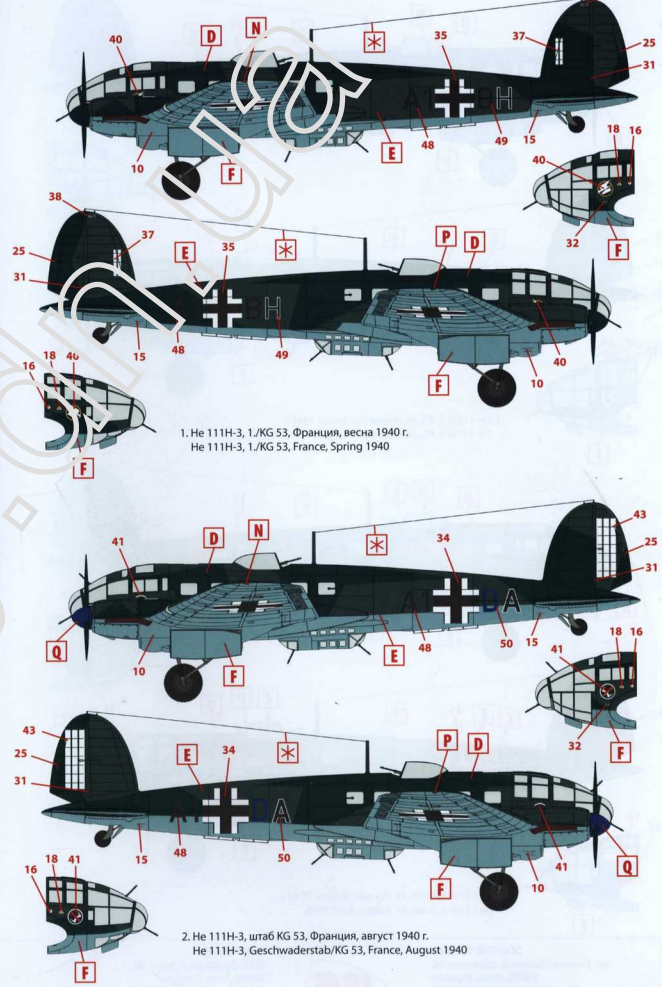

1. He 111H-3, 1./KG 53, Франция, весна 1940 г.
 He 111H-3, 1./KG 53, France, Spring 1940

2. He 111H-3, штаб KG 53, Франция, август 1940 г.
 He 111H-3, Geschwaderstab/KG 53, France, August 1940

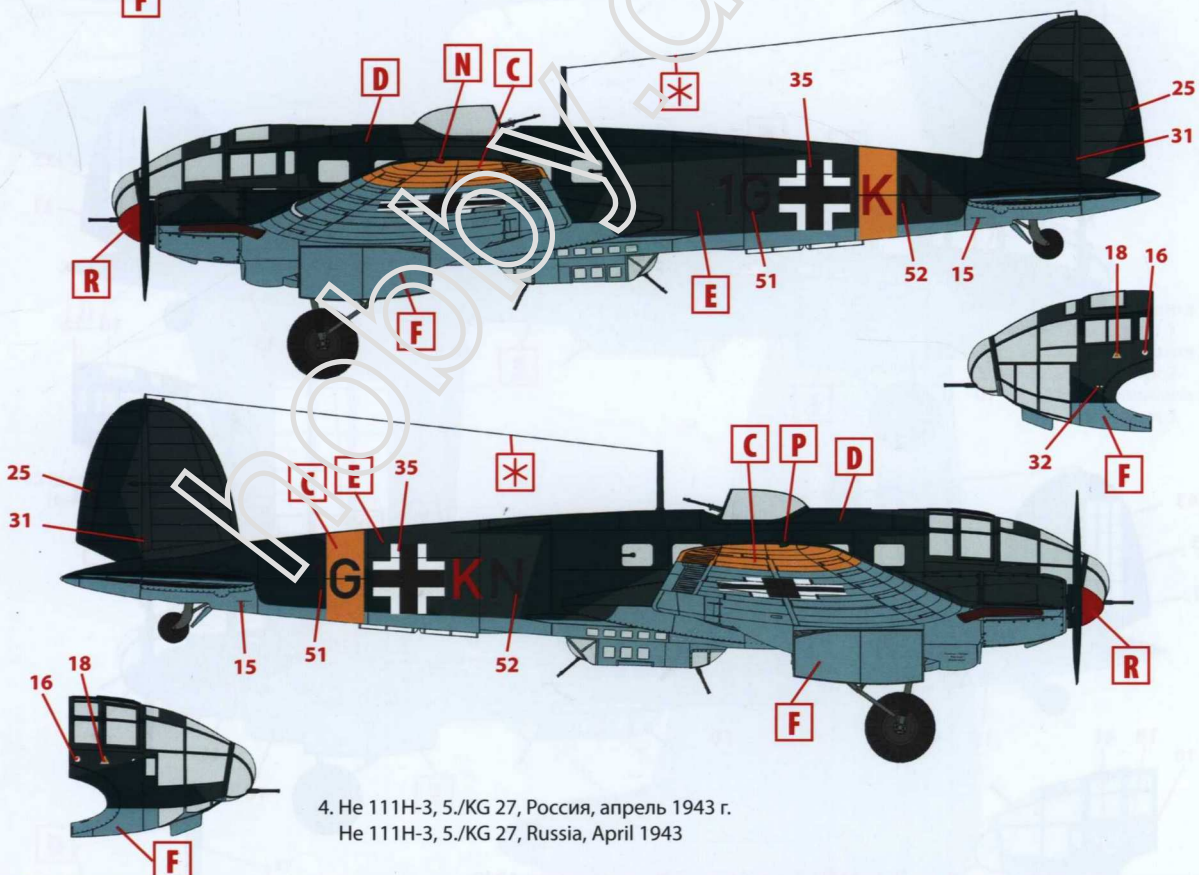
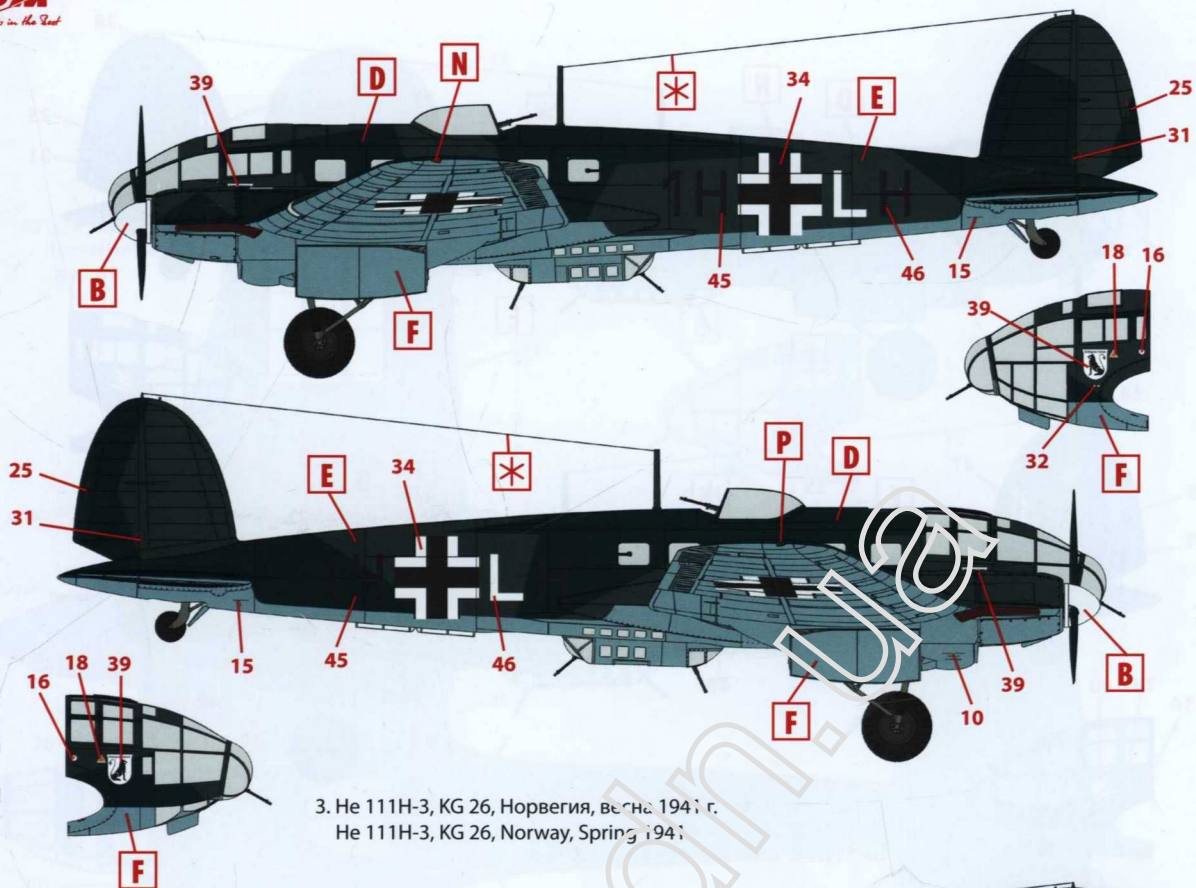

ООО ICM Холдинг
ул. Бориспольская 9, строение 64,
02099, Киев, Украина
Тел./факс: +38(044) 369 54 12
E-mail: export@icm.com.ua

ICM Holding
Borispolskaya, 9, build. 64,
02099, Kiev, Ukraine
Tel./Fax: +38(044) 369 54 12
E-mail: export@icm.com.ua