



Sikorsky CH-54A Tarhe

1/35 SCALE MODEL KIT No 53054

Sikorsky CH-54A Tarhe, Важкий гелікоптер США

Гелікоптер CH-54 Tarhe був створений компанією Sikorsky Aircraft, засновником якої є видатний авіаконструктор українського походження Ігор Сікорський. Перший політ гелікоптера (що спочатку мав позначення S-64) відбувся 9 травня 1962 року. Вертоліт був побудований за модульним принципом, що спрощувало його обслуговування та ремонт. Потужні лебідки гелікоптера дозволяли йому підбирати вантажі на режимі зависання, без необхідності посадки на землю. Гелікоптер успішно застосовувався під час бойових дій у В'єтнамі, де евакуював пошкоджені літаки та різні вертольоти, транспортував на зовнішній підвісці артилерійські гармати, автомобілі, танки і навіть бойові катери. Крім перевезення бойової техніки, він також залучався для скидання надпотужних бомб з метою розчищення лісу під аеродромний майданчик. Свого часу цей гелікоптер встановив 10 світових рекордів для свого класу, серед яких – підйом 15-тонного вантажу на висоту 3307 м. Цивільні версії гелікоптера (Erickson S-64 Airplane) успішно експлуатуються й донині.

Тактико-технічні характеристики Sikorsky CH-54A Tarhe

Довжина фюзеляжу, м	21,46
Висота, м	5,67
Маса порожнього, кг	7820
Максимальна злітна маса, кг	19050
Корисне навантаження, кг	до 9000
Двигуни	2xPratt Whitney T73-P-1, 2x4500 к.с.
Максимальна швидкість, км/год	203
Крейсерська швидкість, км/год	169

ФАРБИ, ЩО ВИКОРИСТОВУЮТЬСЯ / USED COLORS:

COLOR	ICM	Revell	Tamiya
A Гумовий чорний Rubber Black	1039	6	XF85
B US Темно-зелений US Dark Green	1072	363	XF13
C Помаранчевий Deep Orange	1006	-	-
D Небесно-сіра Sky Gray	1033	-	-
E 4B0 4B0 Green	1073	361	XF62
F Жовтий Deep Yellow	1003	-	XF3
G Червоний Deep Red	1007	131	-
H Алюміній Aluminium	1023	99	XF16

Для отримання глянцевого, сатинового чи матового ефекту – використовуйте наші лаки!

For a glossy, satin or matte effect - use our varnishes!

	2001 МАТОВИЙ ЛАК VARNISH MATT		2002 САТИНОВИЙ ЛАК VARNISH SATIN		2003 ГЛЯНЦЕВИЙ ЛАК VARNISH GLOSS
--	-------------------------------------	--	--	--	--

01 СТАДІЯ СКЛАДАННЯ
ASSEMBLY STEP

03 СКЛАДАЛЬНА ОДИНИЦЯ
ASSEMBLY UNIT

A ФАРБА, ЩО ВИКОРИСТОВУЄТЬСЯ
USED COLOR

***** ЗРОБИТИ САМОМУ
SCRATCH BUILD

x2 ЗРОБИТИ ДВІ ДЕТАЛІ
MAKE 2 PCS

X НЕ КЛЕІТИ
DO NOT CEMENT

✓ ВІДРІЗАТИ
CUT OFF

? ДОВІЛЬНИЙ ВИБІР
OPTIONAL

У В А Г А !
Перед складанням уважно прочитати керівництво з монтажу. Кожна деталь пронумерована. Дотримуватися послідовності монтажу. Необхідні робочі інструменти: ніж і напилек для зачистки деталей; гумова стрічка, клейка стрічка і прищипки для притиснення склеюваних деталей). Деталі з пластику очистити в розчині м'якого миючого засобу і висушити на повітрі для того, щоб фарба і перевірни картинки краще прилипали. Перед приклеюванням перевірити, чи підходять деталі; клей наносити економно. Хром і фарбу видалити з поверхонь склеювання. Невеликі деталі пофарбувати перед тим, як вони будуть видалені з рамок. Фарбу необхідно добре просушити, тільки після цього продовжувати складання. Кожну відповідну перевірни картинку вирізати окремо і приблизно на 20 секунд занурити в теплу воду. На позначеному місці картинку відокремити від паперу і пригладити промокальним папером.

ТОВ ICM Холдинг
вул. Бориспільська 9, корпус 64,
02099, Київ, Україна
Тел./факс: +38(044) 369 54 12
E-mail: export@icm.com.ua



ICM Holding
9 Boryspilska str., build. 64
02099, Kyiv, Ukraine
Tel./Fax: +38(044) 369 54 12
E-mail: export@icm.com.ua

Sikorsky CH-54A Tarhe, US Heavy Helicopter

The CH-54 Tarhe helicopter was developed by Sikorsky Aircraft, a company founded by the prominent Ukrainian aircraft designer Igor Sikorsky. The first flight of the helicopter (originally named S-64) took place on May 9, 1962. The helicopter was built on a modular principle, which simplified its maintenance and repair. It had a tall three-post landing gear with a front support, which allowed a tractor with a trailer approach its fuselage freely. The helicopter's powerful winches allowed it to pick up cargo in a hover mode, without the need to land on the ground. During the Vietnam War it evacuated damaged airplanes and various helicopters, transported artillery pieces, cars, tanks and even combat boats on an external sling. It was also used to drop high-powered bombs to clear the forest for an airfield. This helicopter set 10 world records for its class, including lifting a 15-ton cargo to 3307 meters. The civilian version of the helicopter (Erickson S-64 Airplane) is still in successful operation today.

Tactical and Technical Specifications of Sikorsky CH-54A Tarhe

Length fuselage, m	21.46
Height, m	5.67
Empty weight, kg	7820
Max take-off weight, kg	19050
Payload, kg	up to 9000
Engines	2xPratt Whitney T73-P-1, 2x4500 hp
Max Speed, km/h	203
Cruising speed, km/h	169

COLOR	ICM	Revell	Tamiya
J Сталь Natural Steel	1025	91	X11
K Масляна сталь Oily Steel	1026	-	-
L Збройовий метал Gun metal	1027	-	X10
M Іржава латунь Rusty Brass	1019	95	-
N Темно-морський сірий Dark Sea Grey	1034	-	AS11
P Напівпрозорий червоний Clear Red	1011	731	X27
Q Зелено-сірий Green-Grey	1063	59	XF21



Використовуйте набір фарб від ICM #3026
Best to be used with ICM Paint Set #3026

С А У Т І О Н !
Read the instructions thoroughly prior to assembly. Each component is numbered. Adhere to specified sequence of assembly. Tools required: knife and file for removal of components from frame; rubber bond, adhesive tape and clothes pegs for clamping components together after applying adhesive. Clean plastic components in a mild detergent solution and allow to air-dry so that paint and transfers adhere better. Prior to applying adhesive, check to see whether the components fit together; apply adhesive sparingly. Remove chrome and paint from the contact surfaces. Paint small components before removing them from the frame. Allow paint to dry well, and only then continue to assemble. Cut out each transfer individually and immerse in warm water for approx. 20 seconds. Slide transfer off paper and into designated position, then press on with blotting paper.

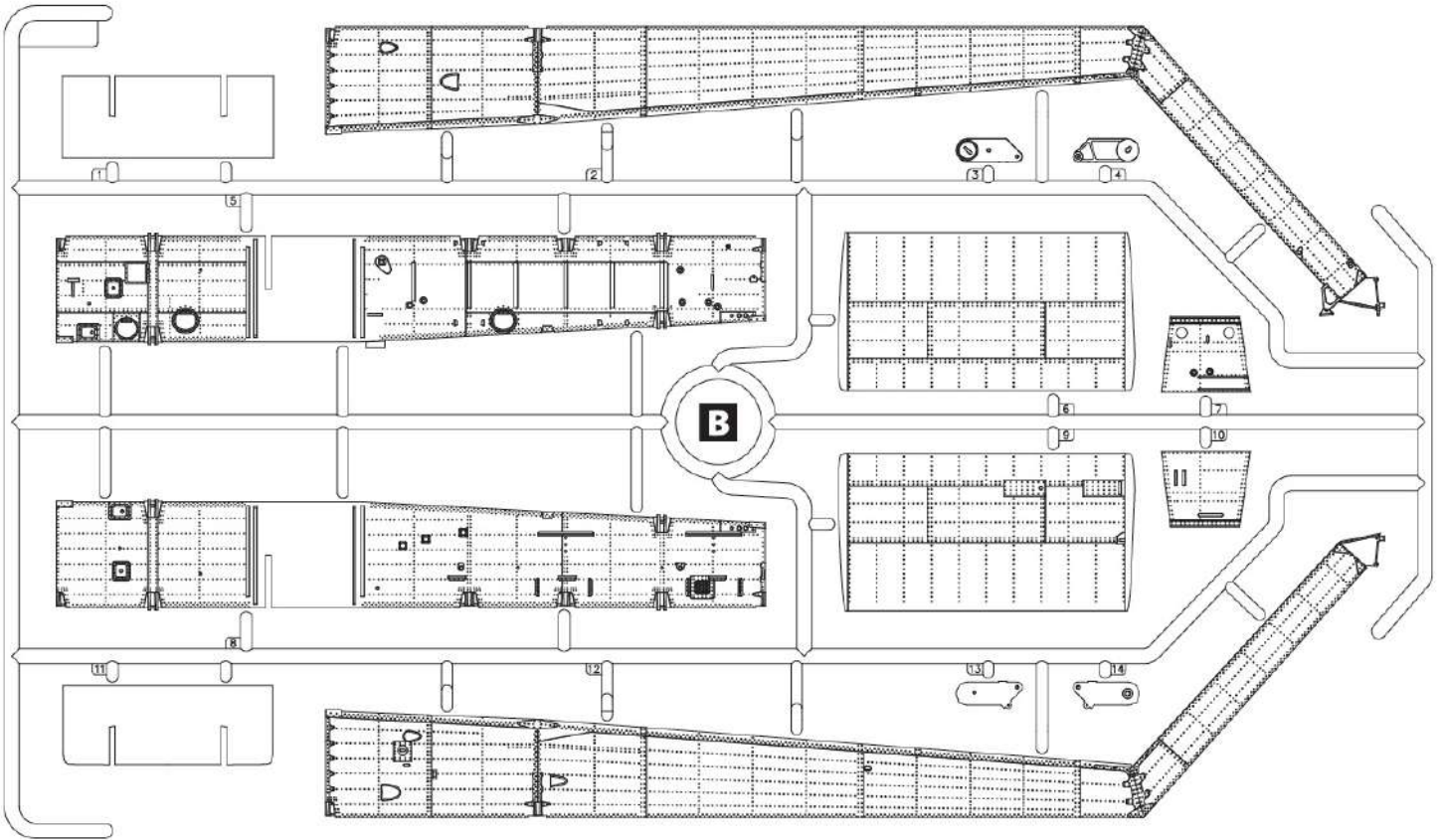
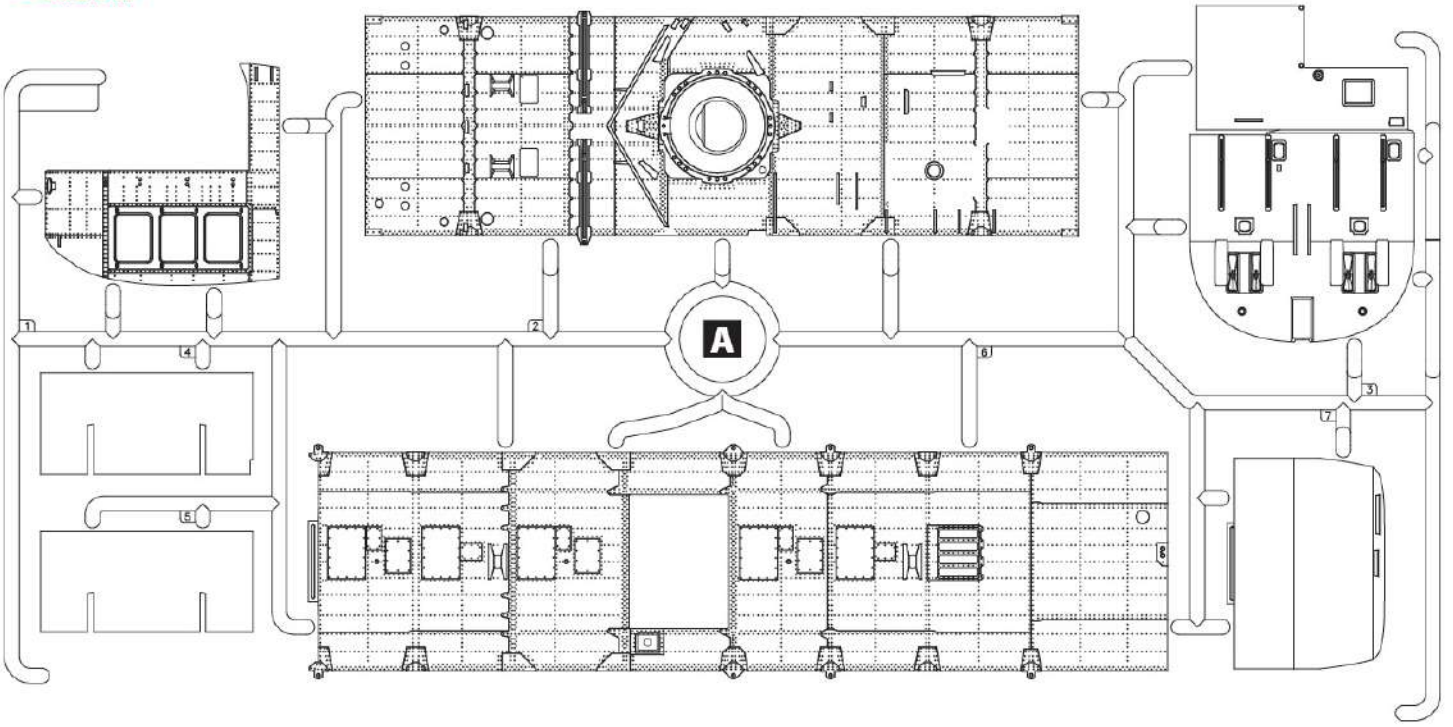

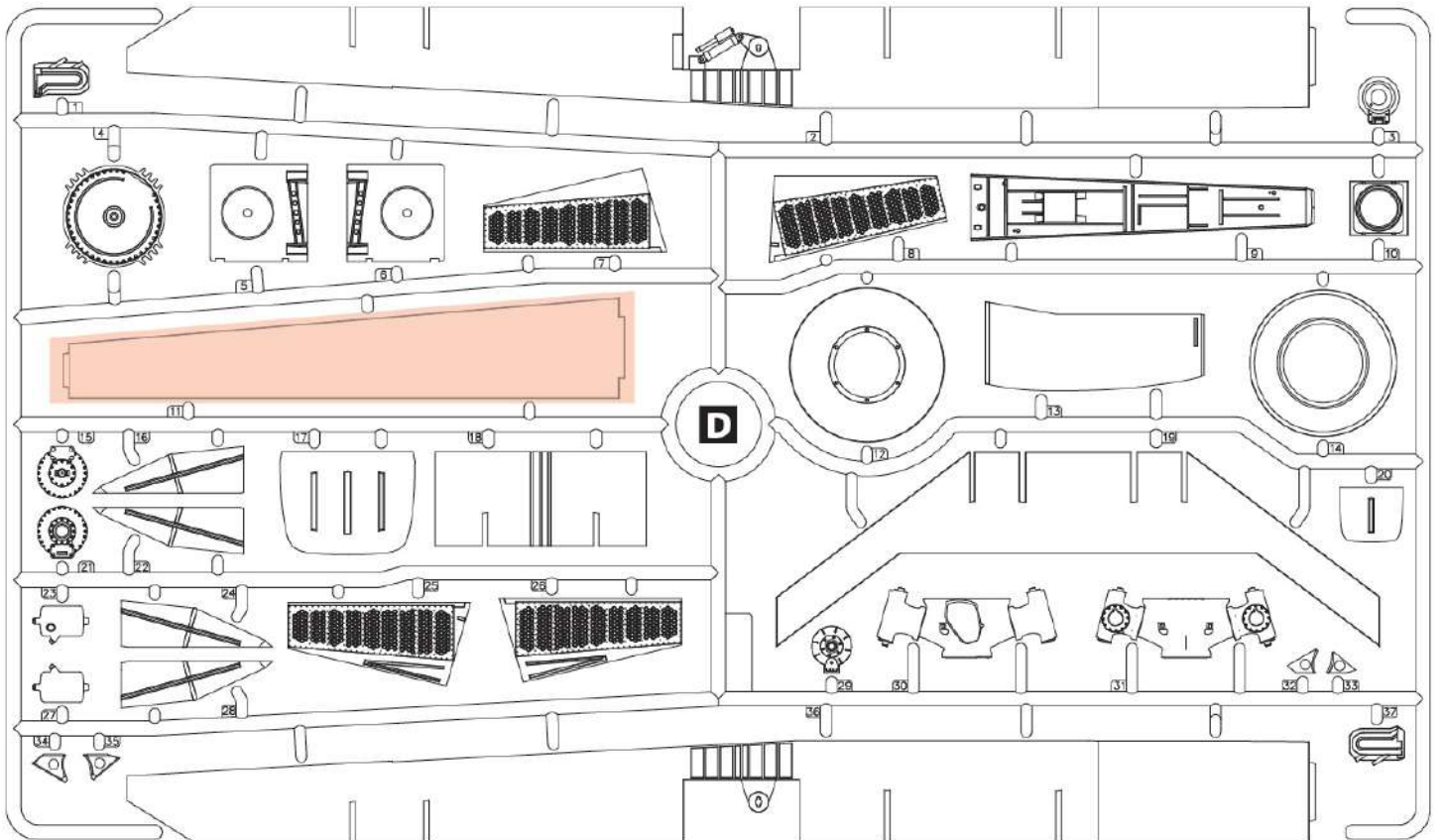
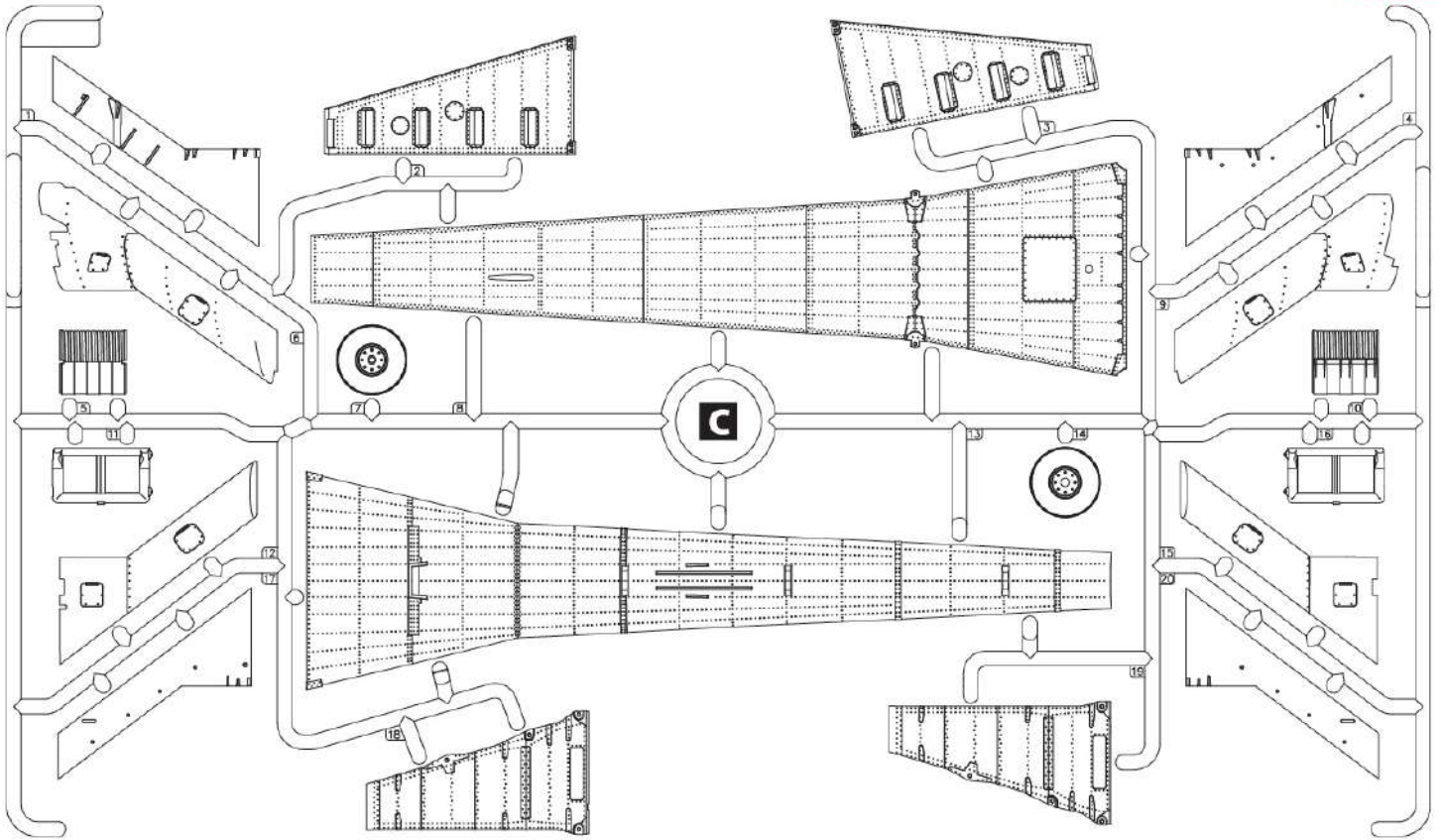

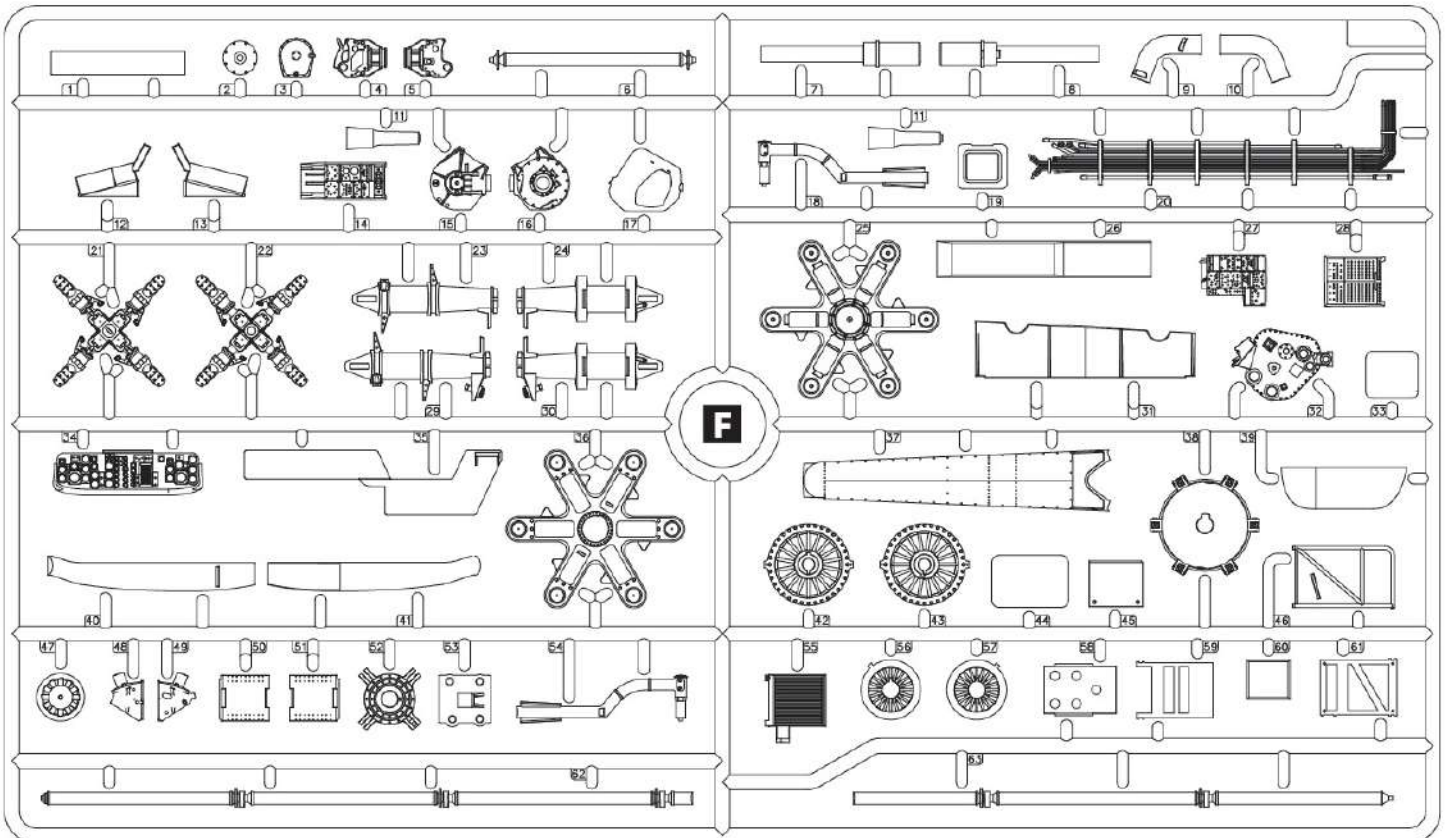
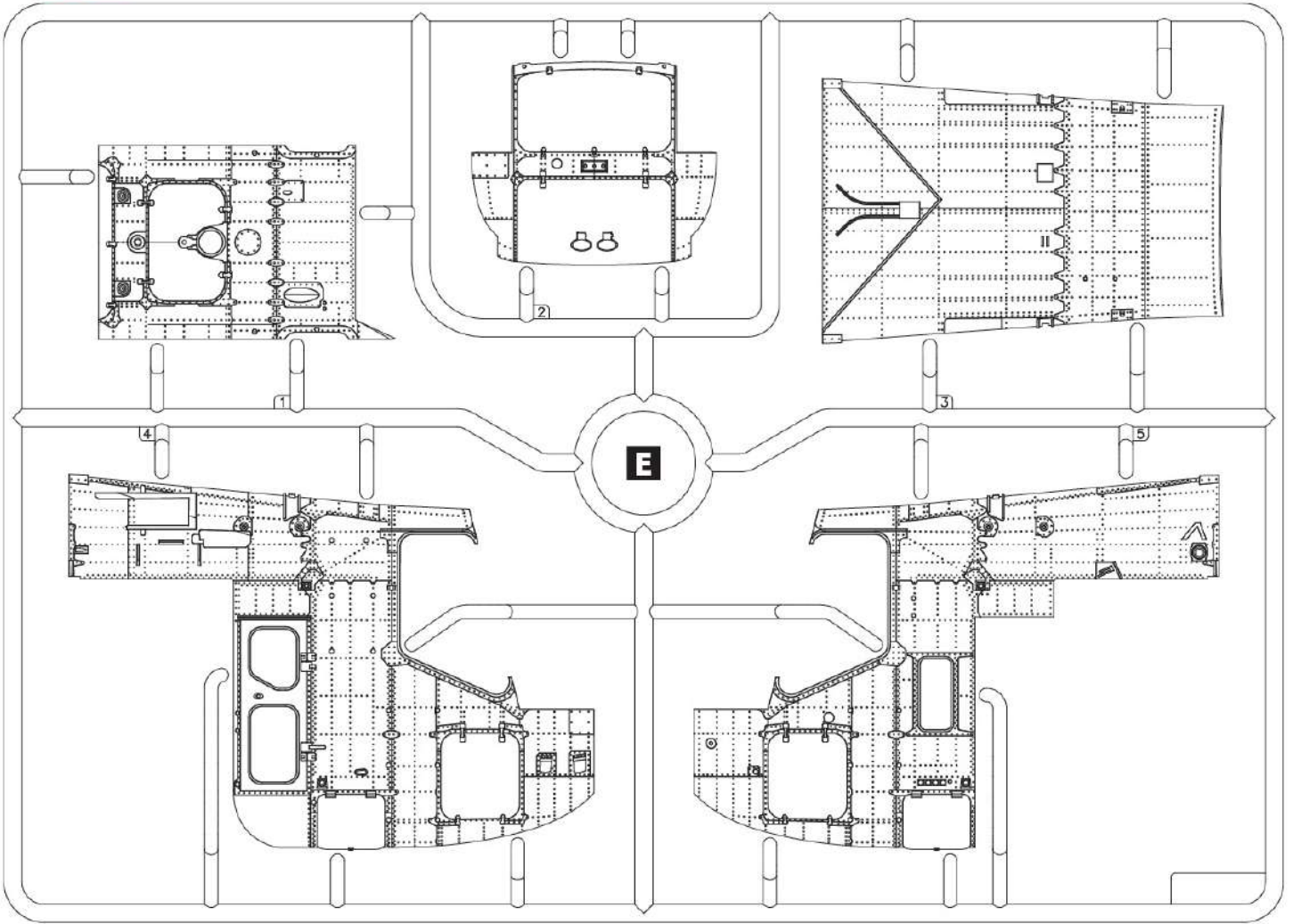

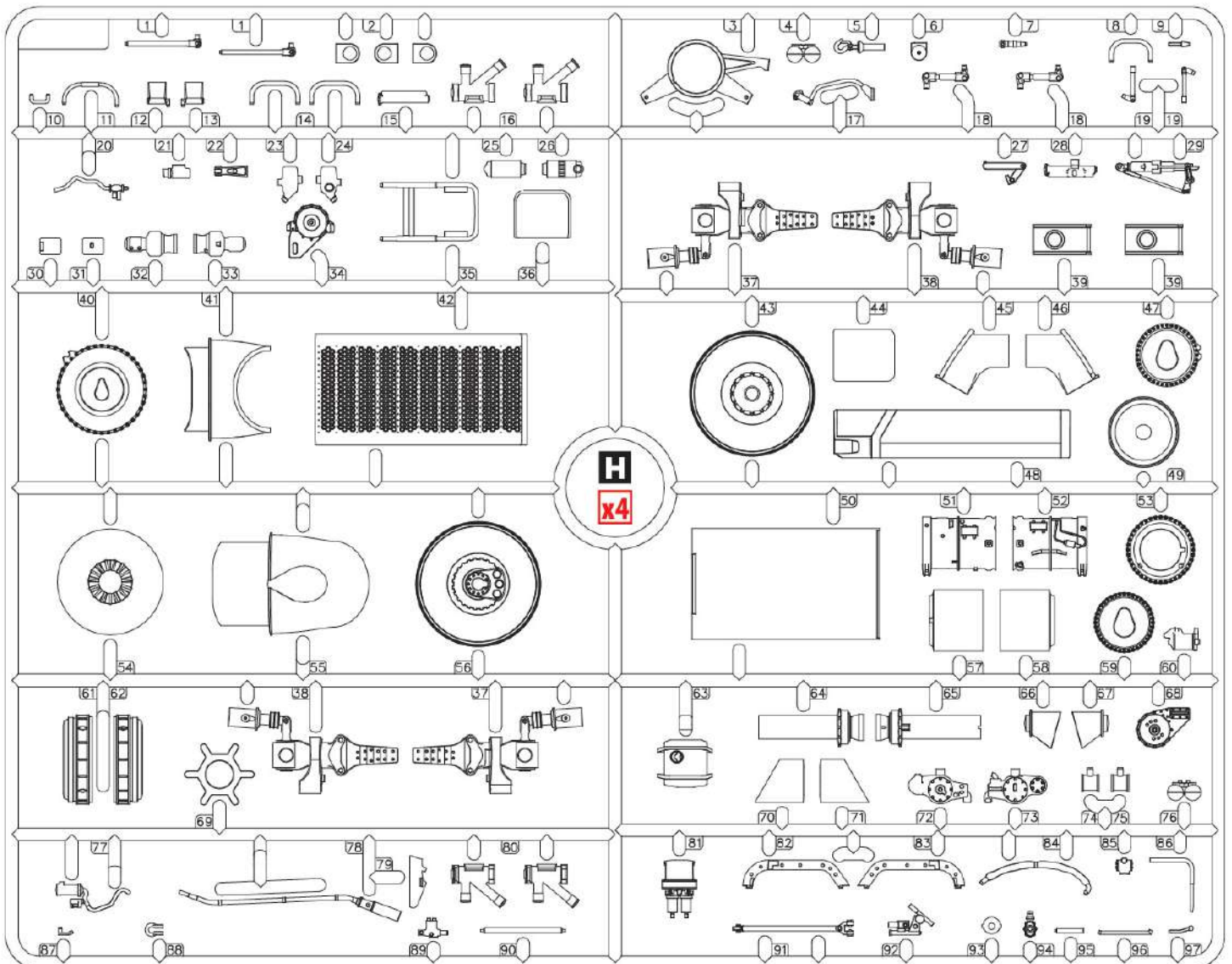
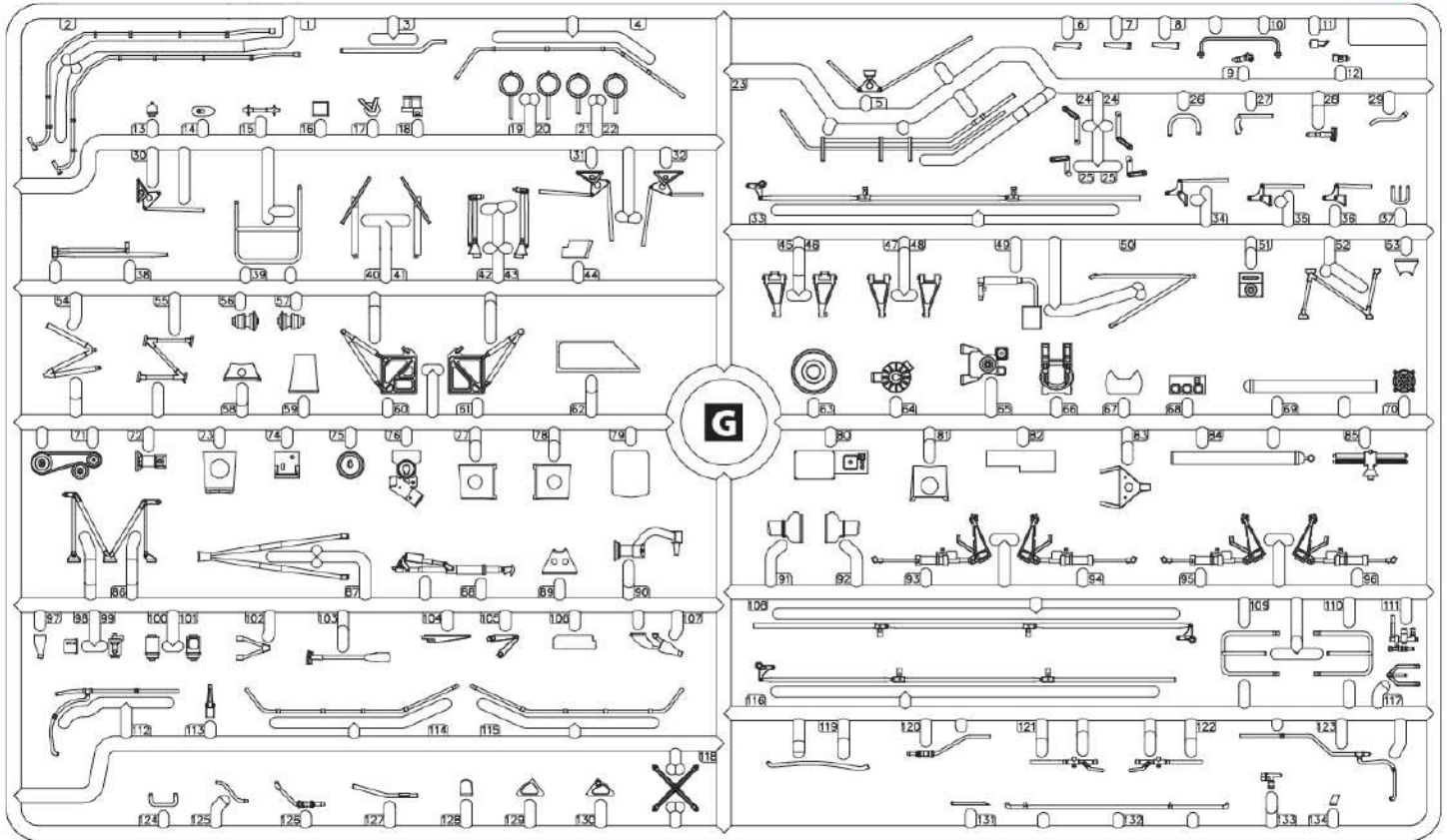

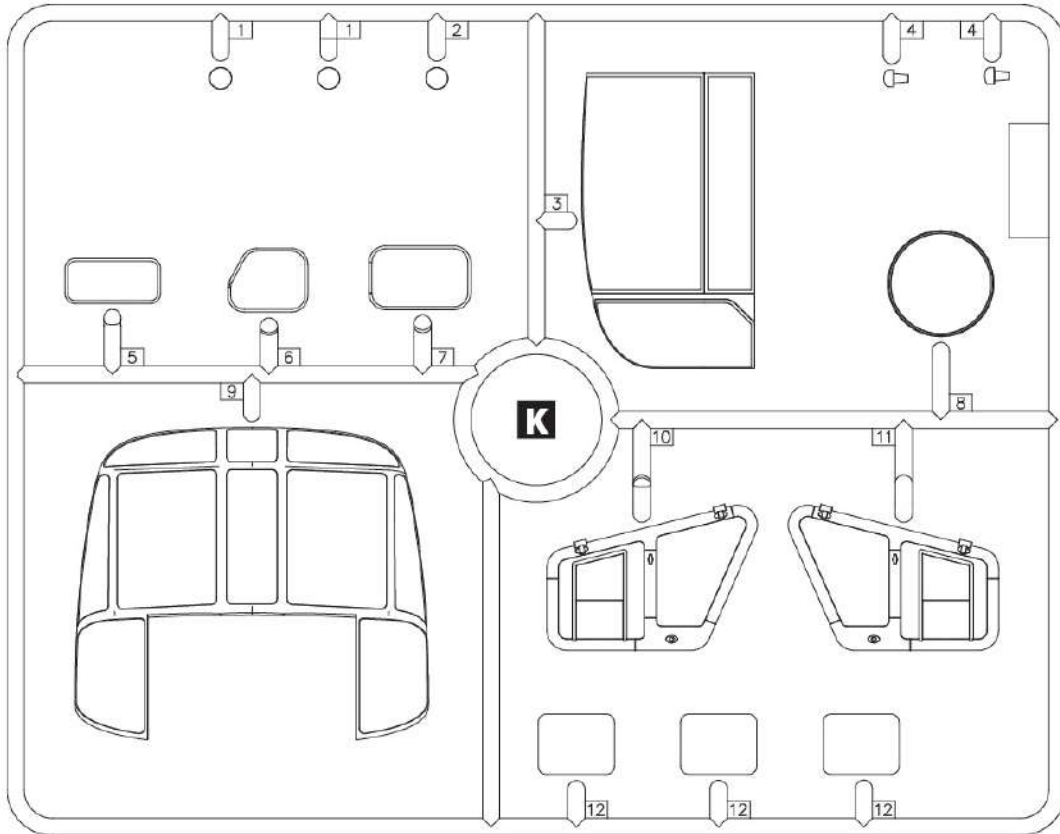
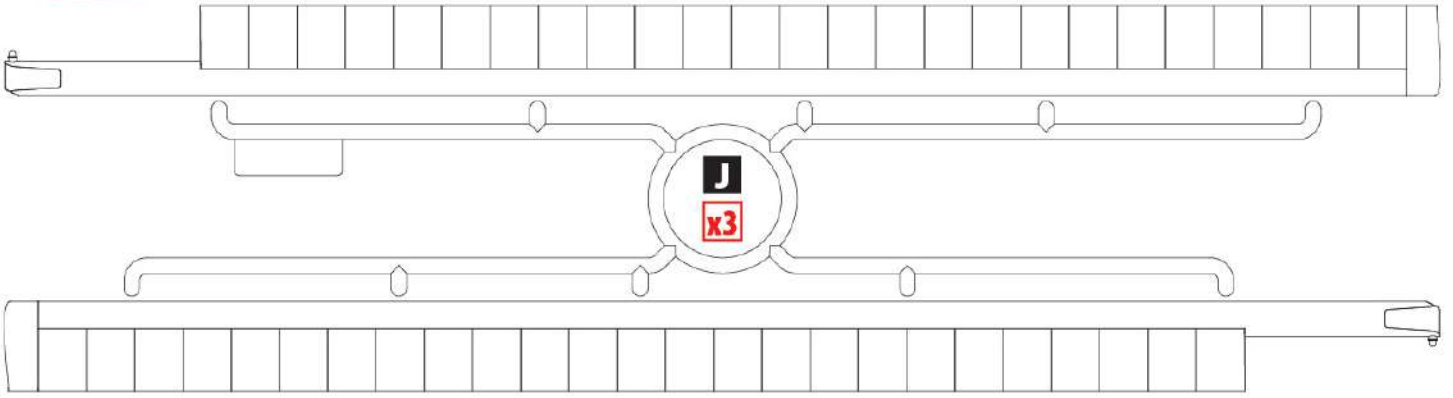

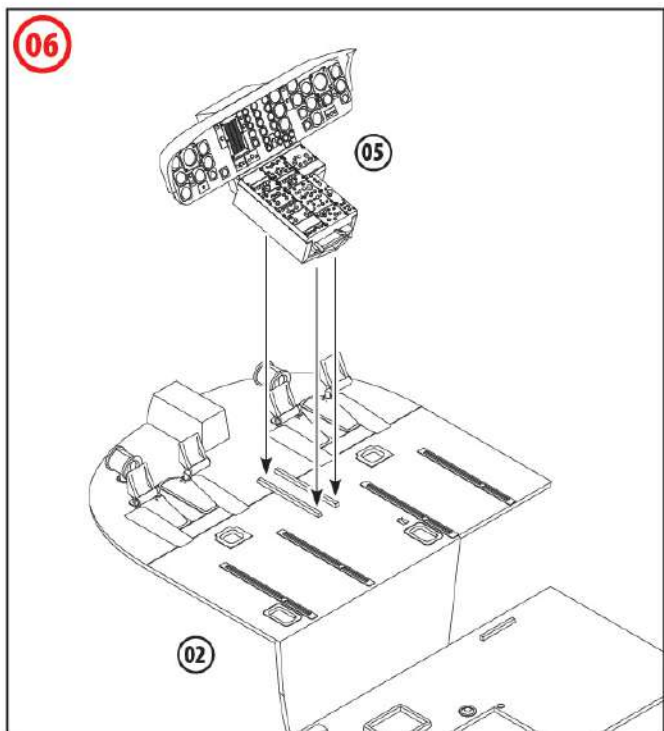
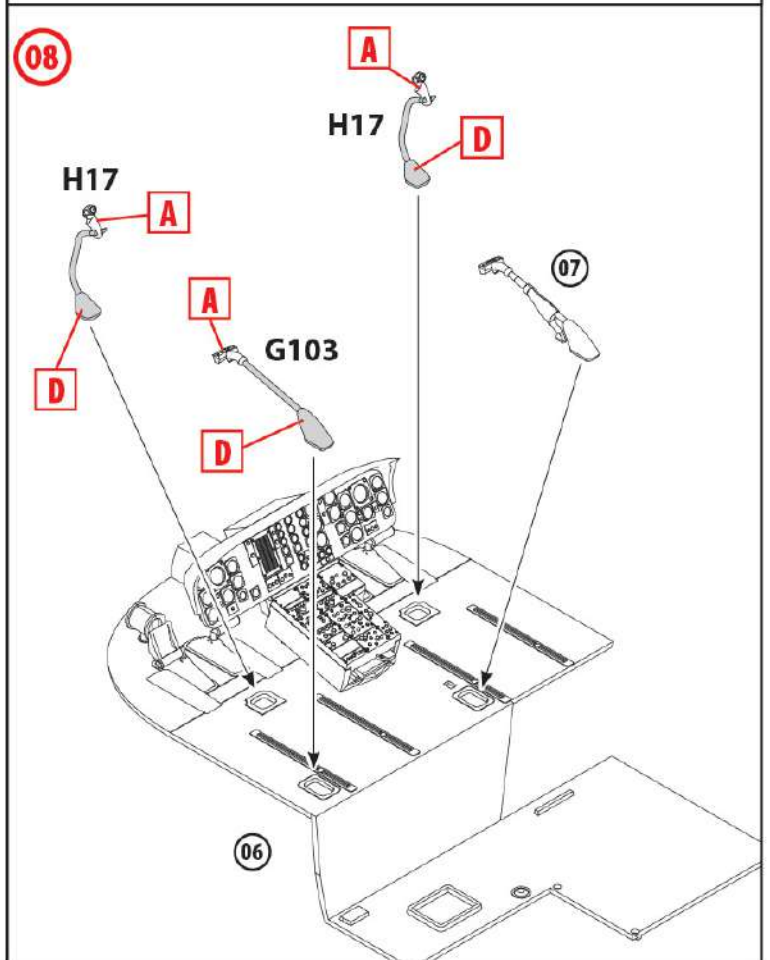
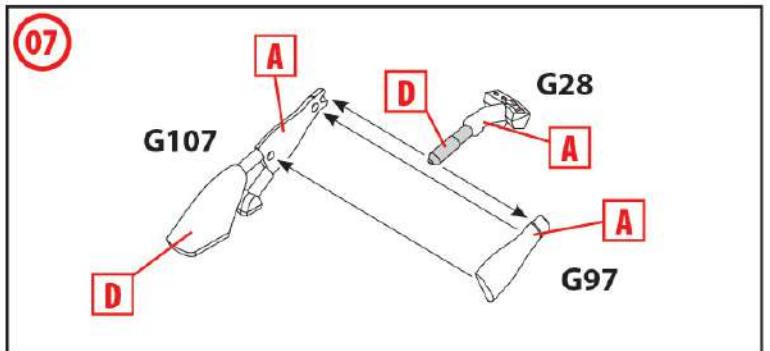
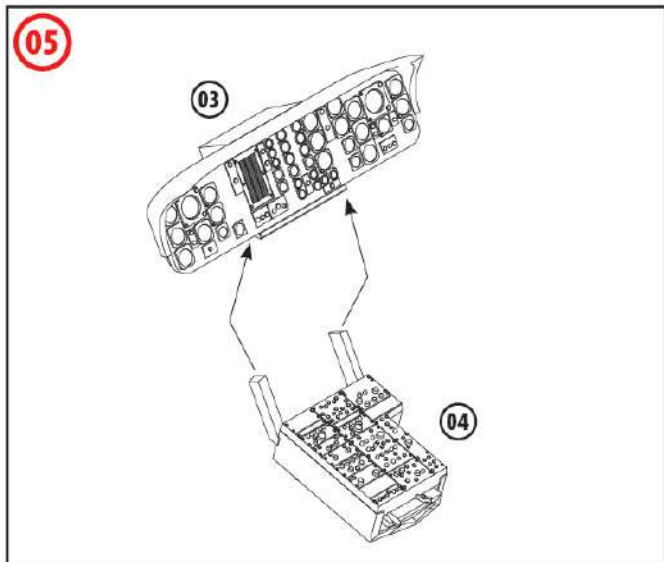
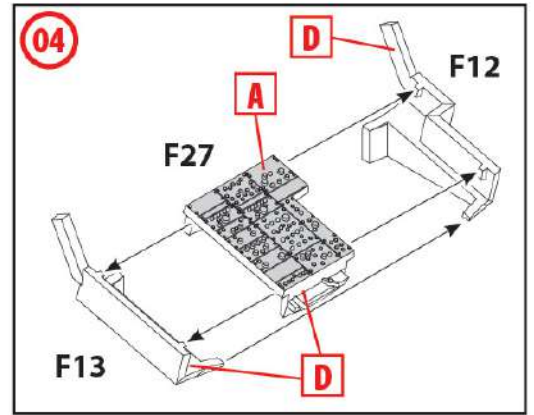
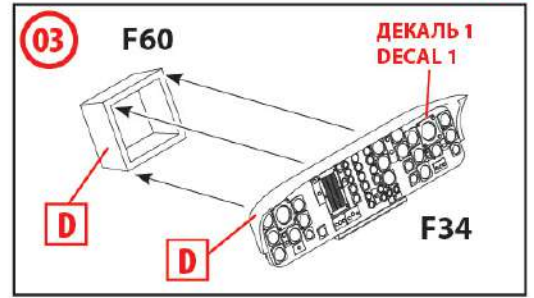
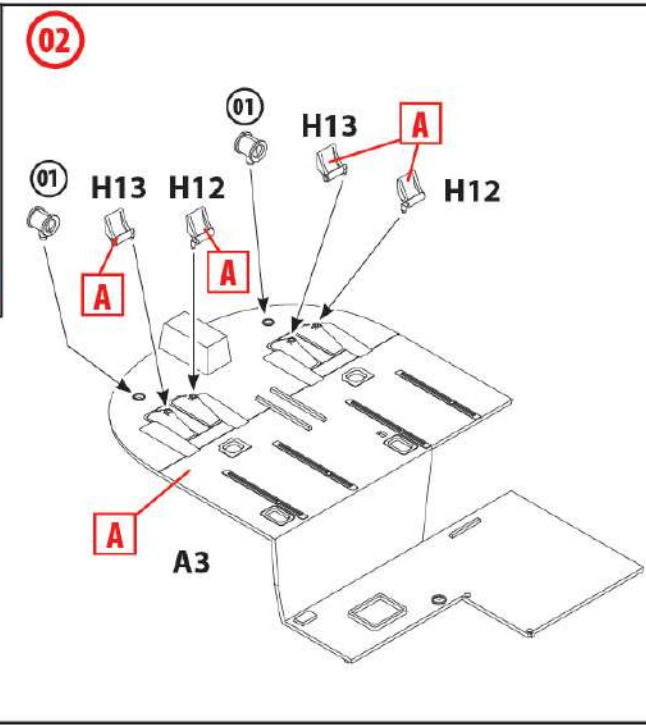
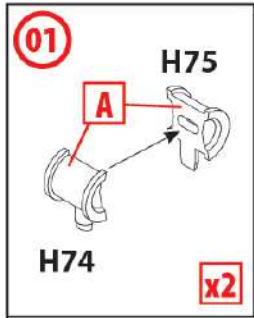

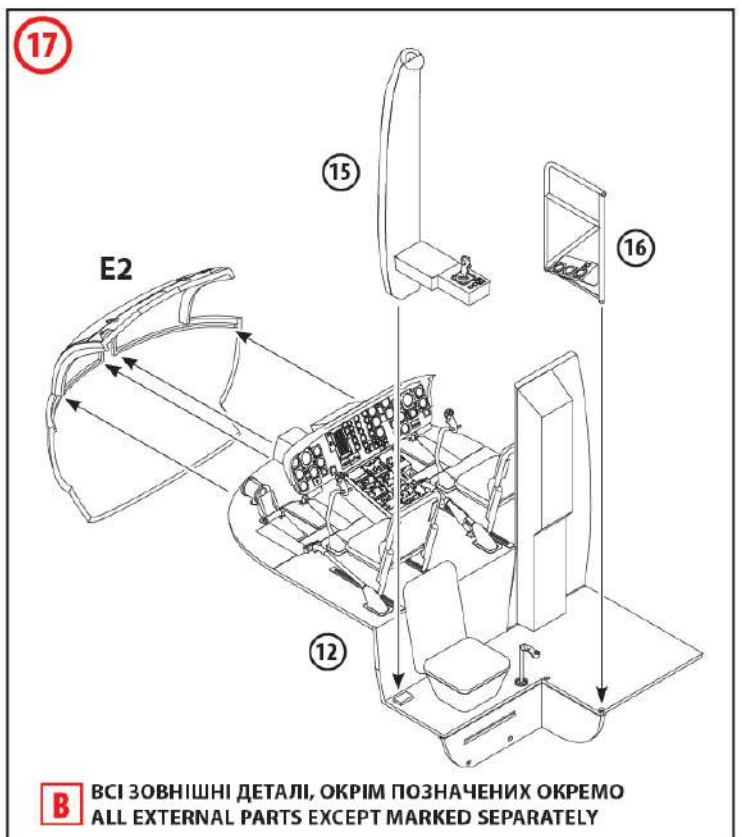
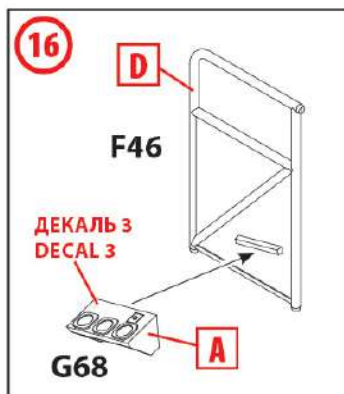
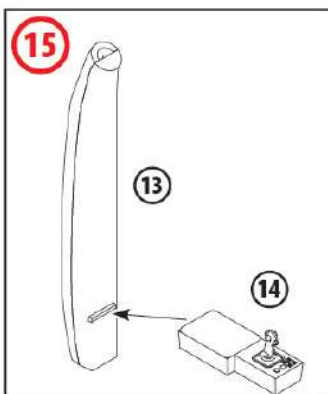
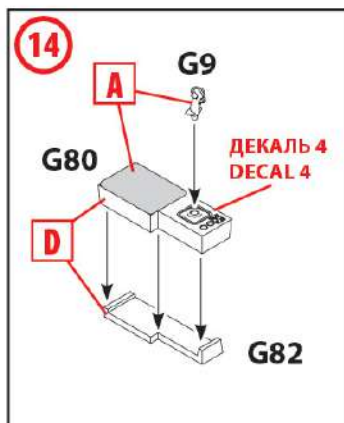
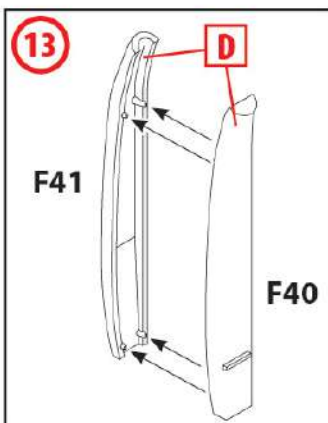
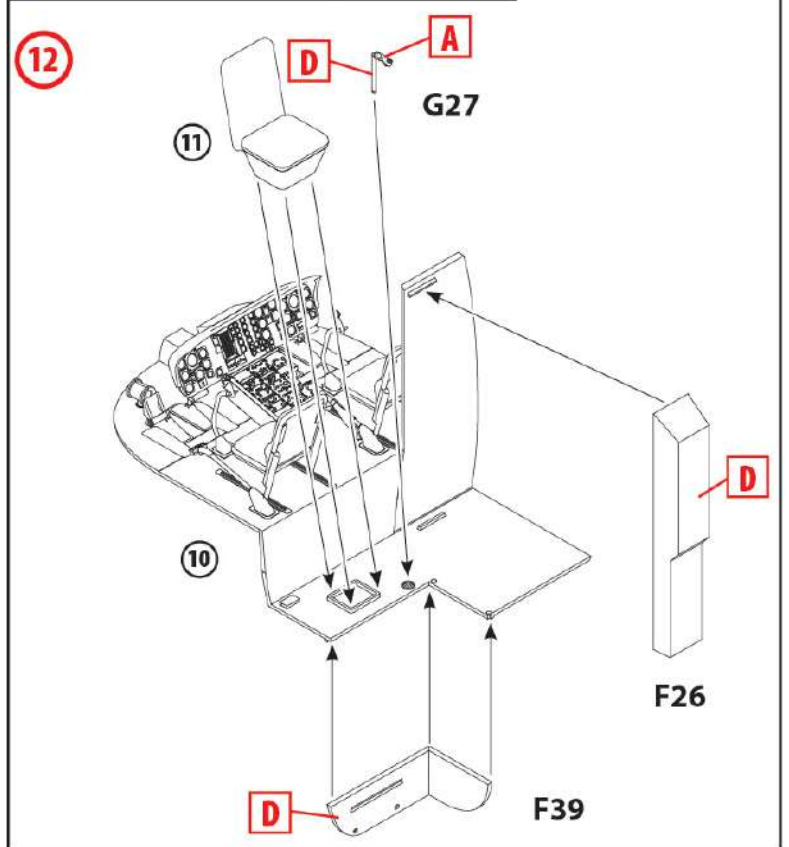
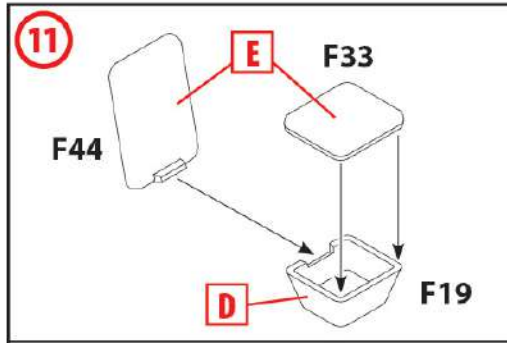
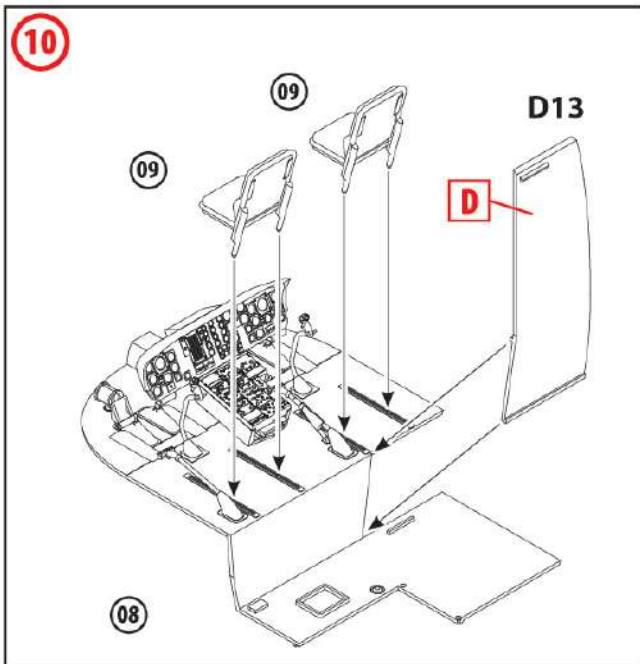
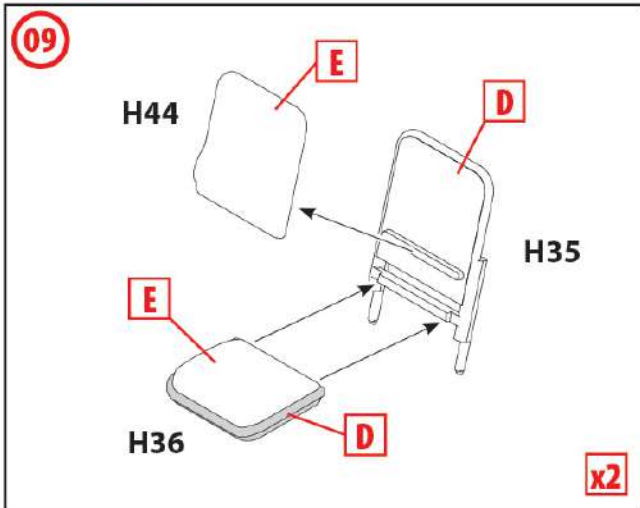

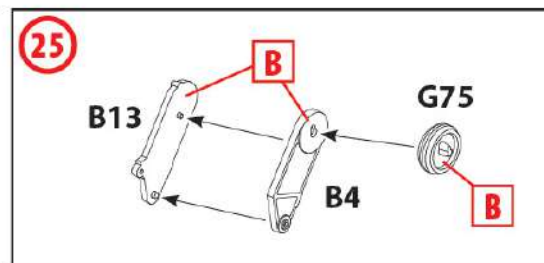
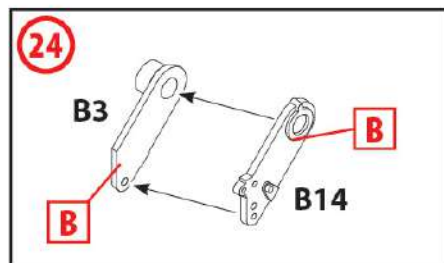
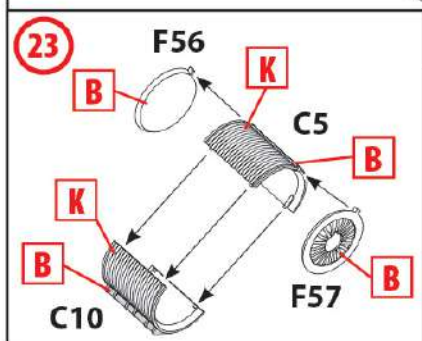
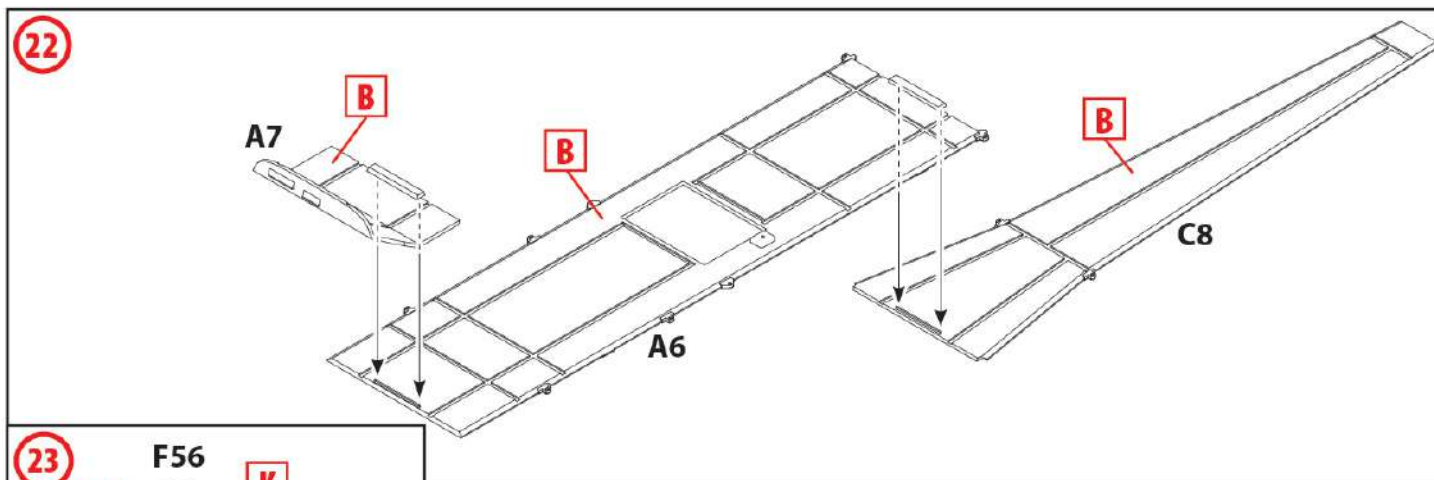
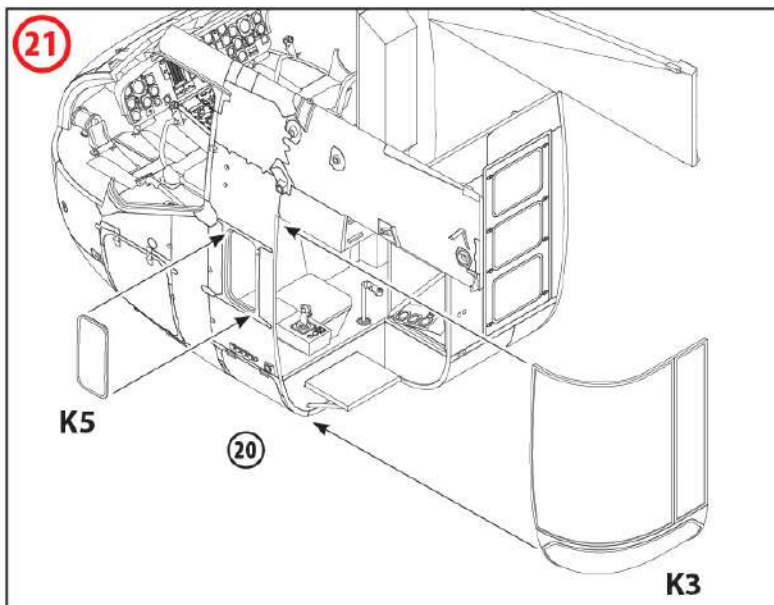
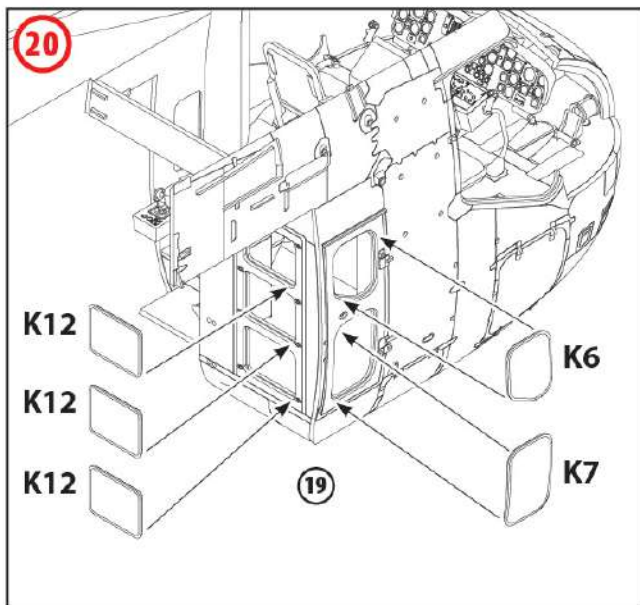
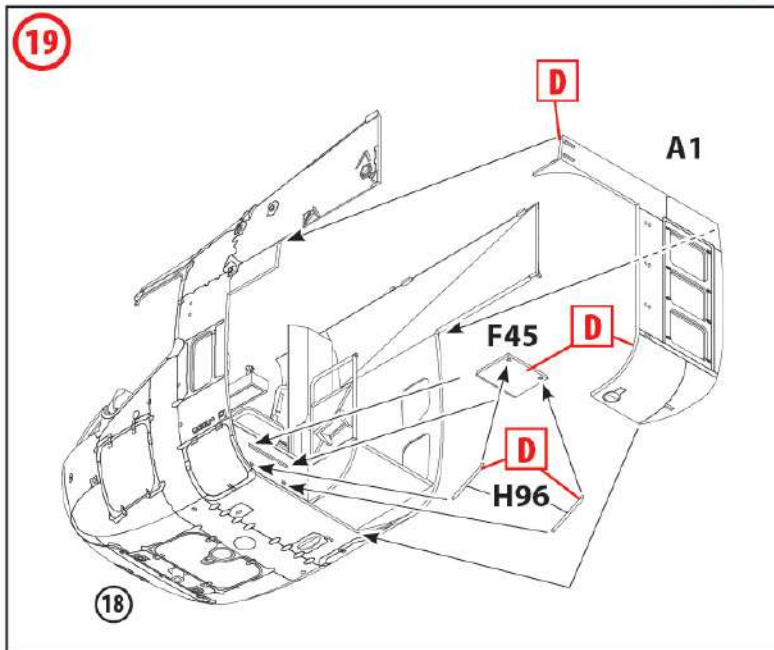
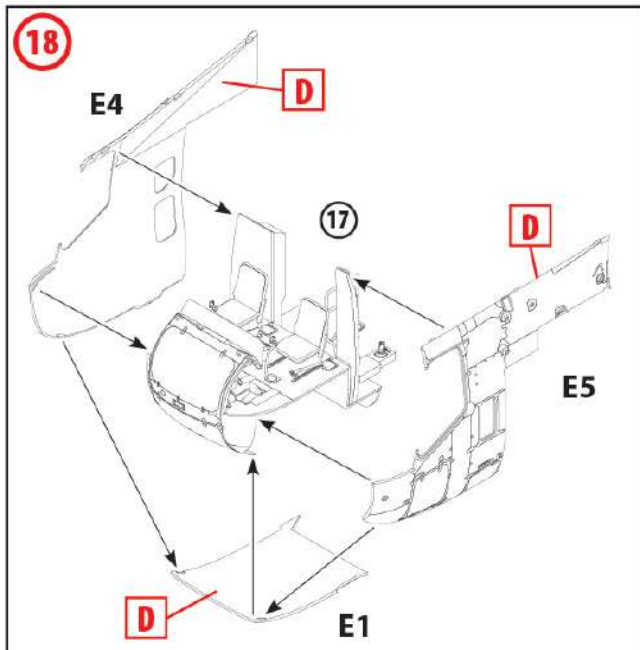

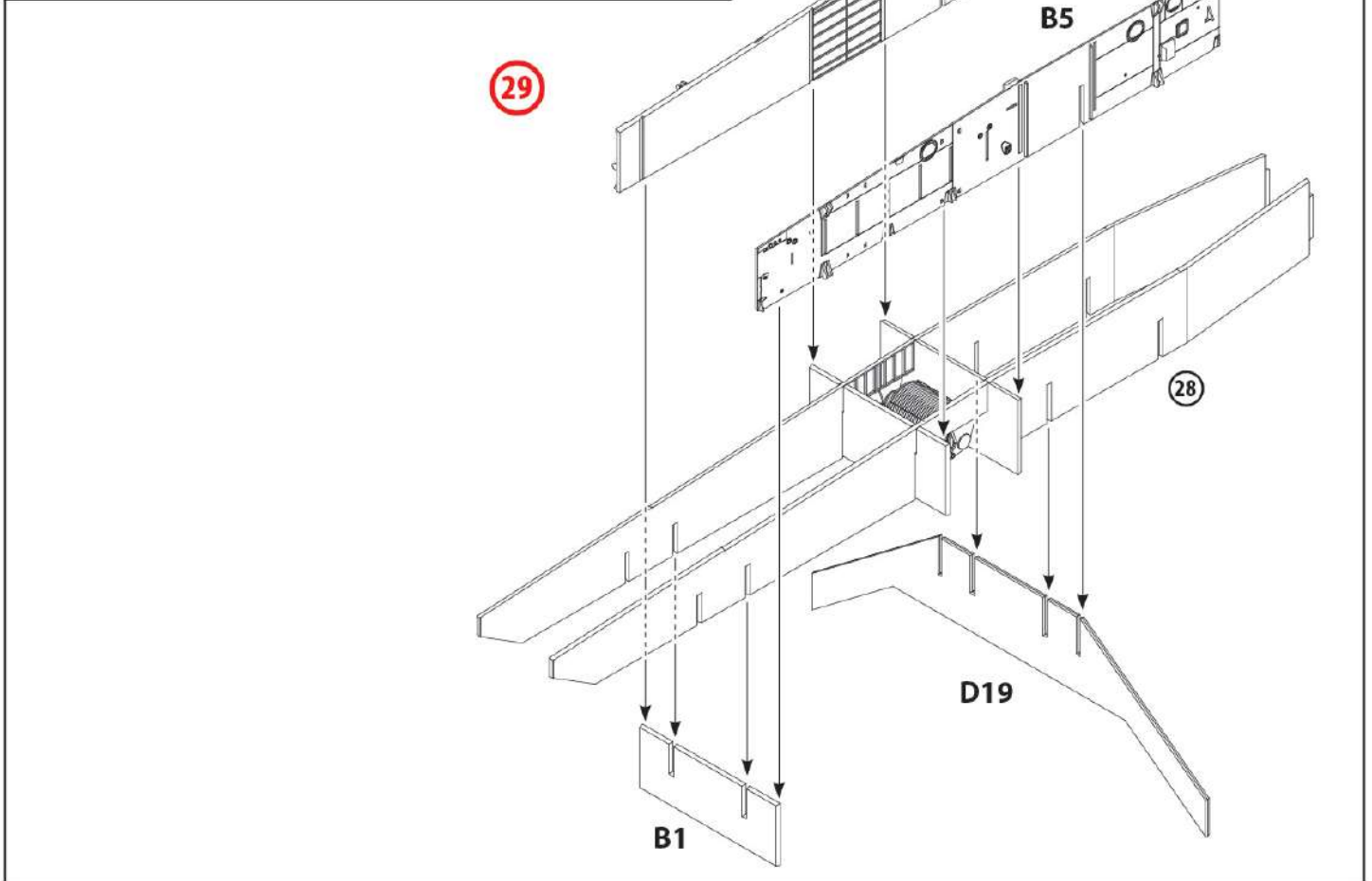
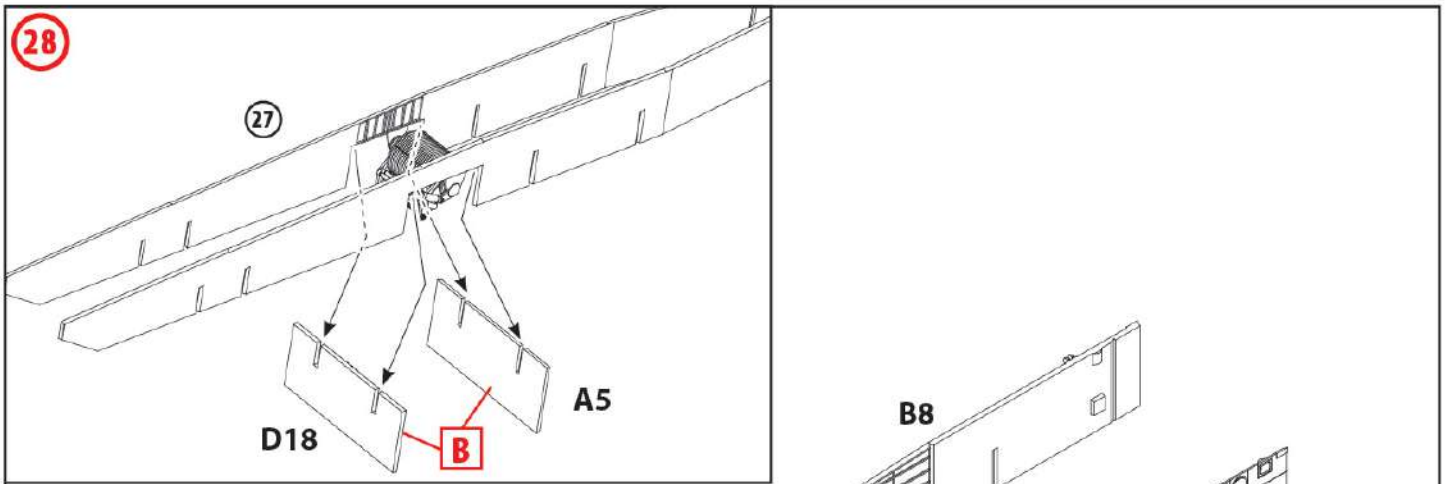
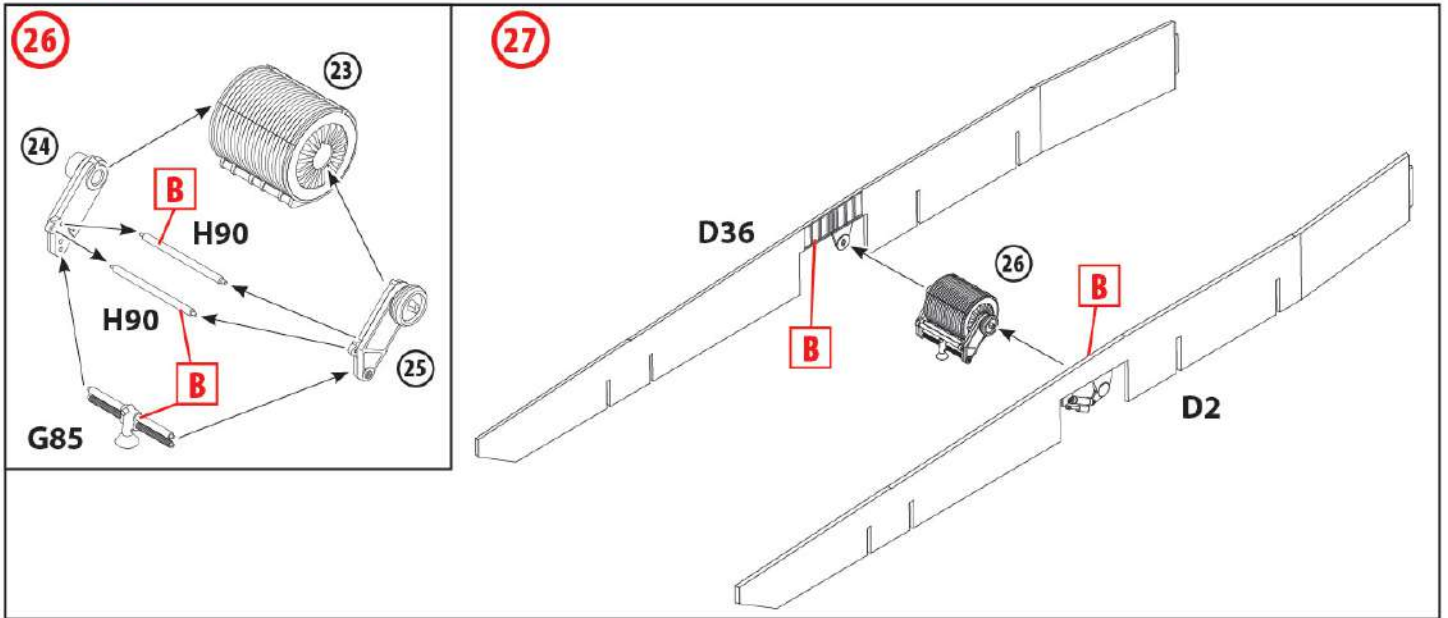

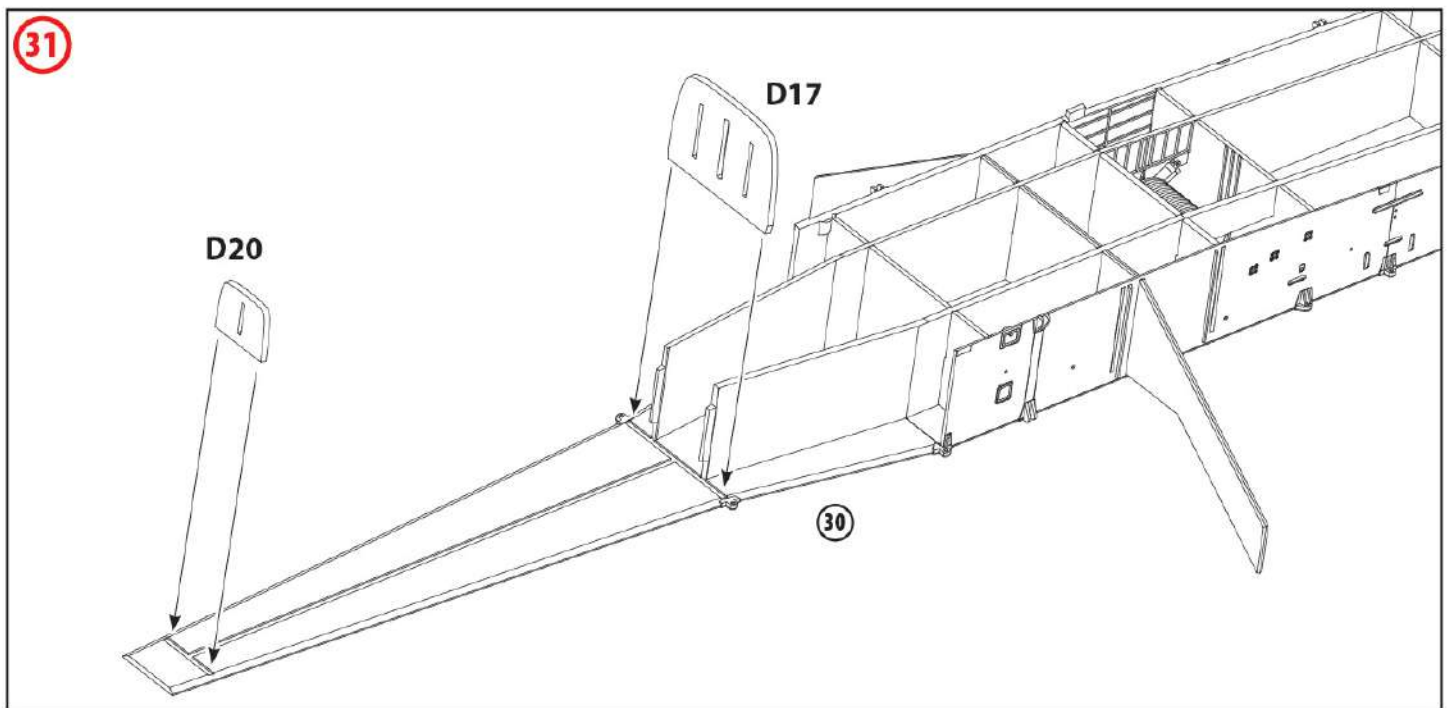
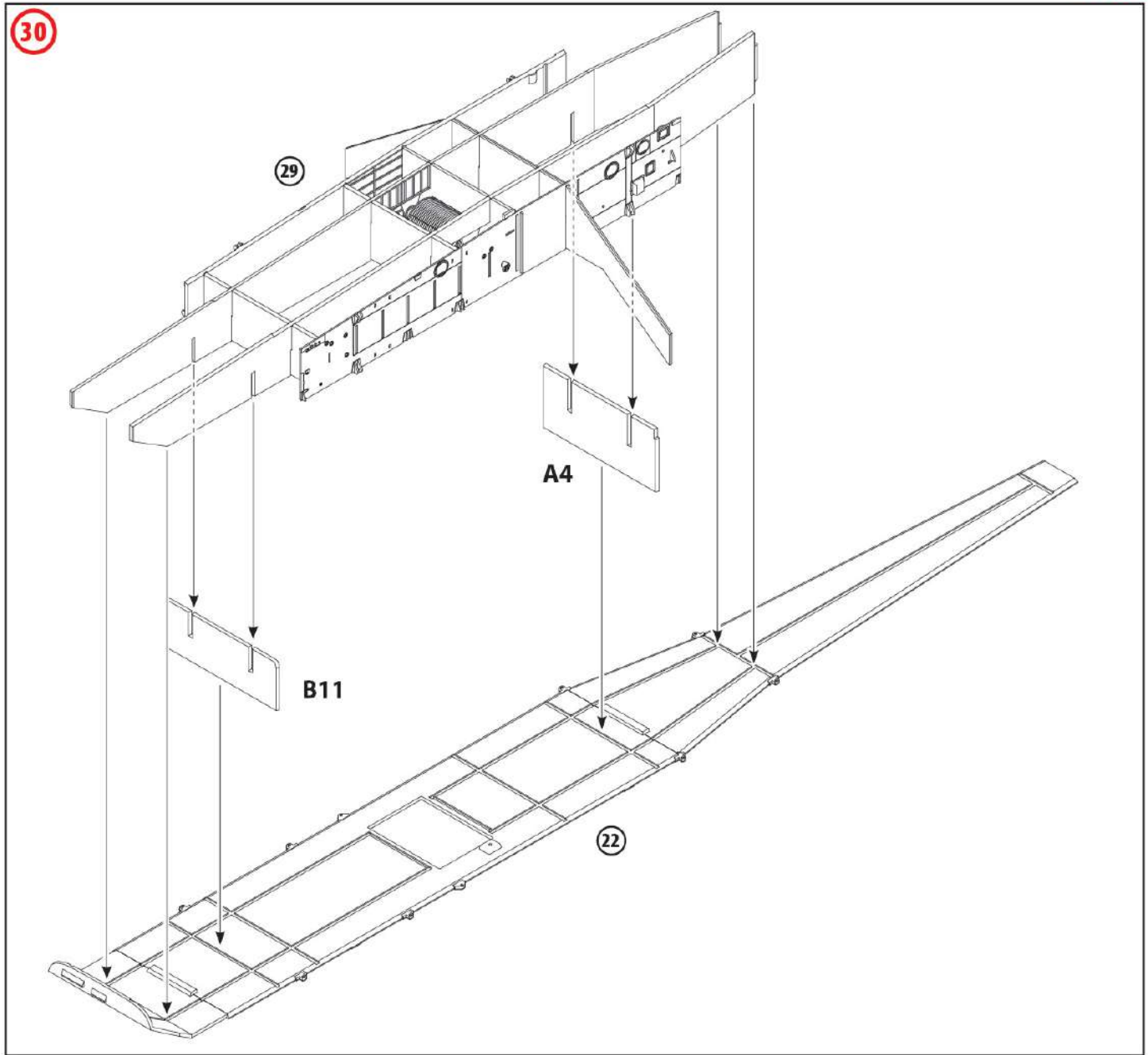

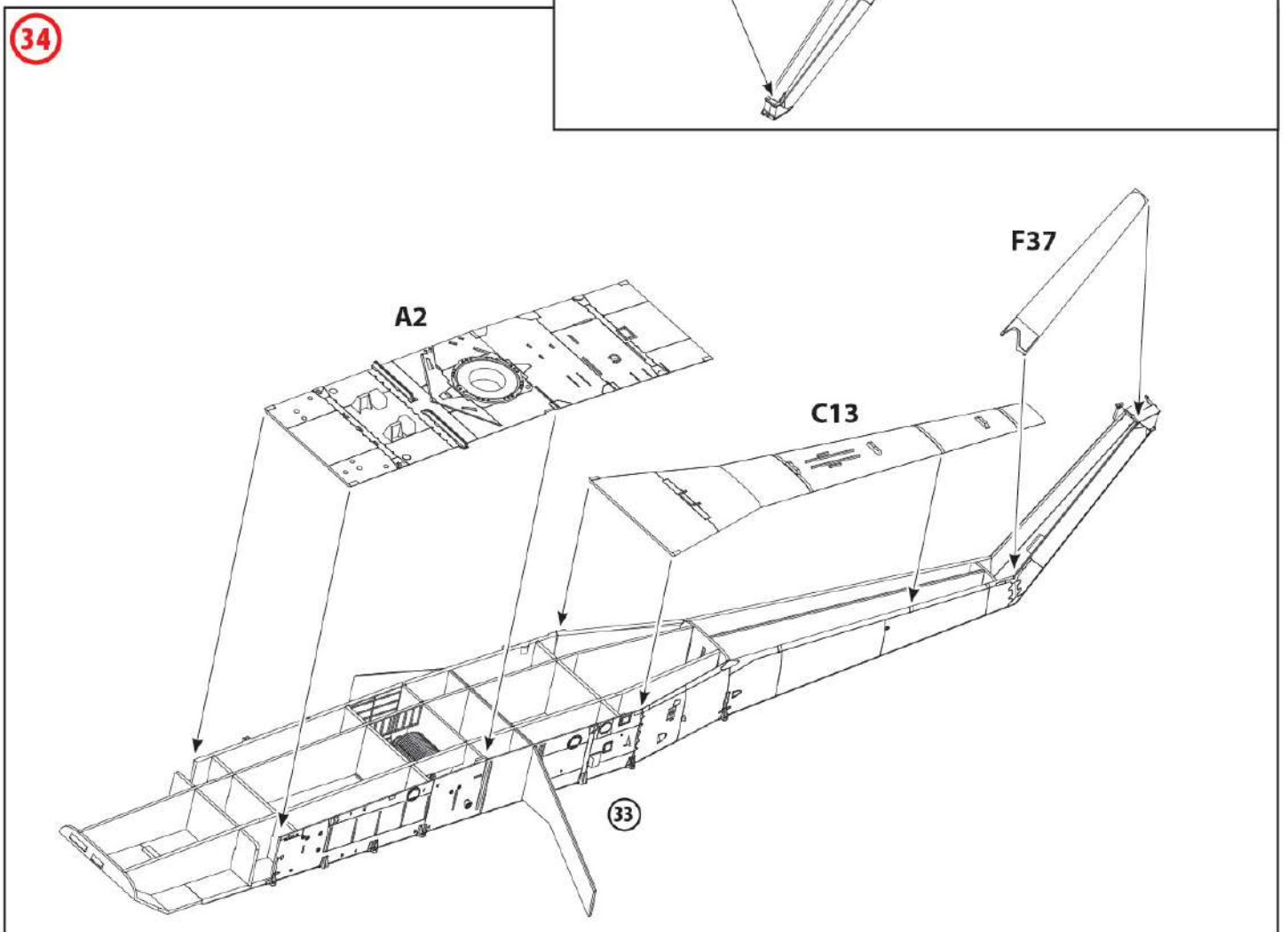
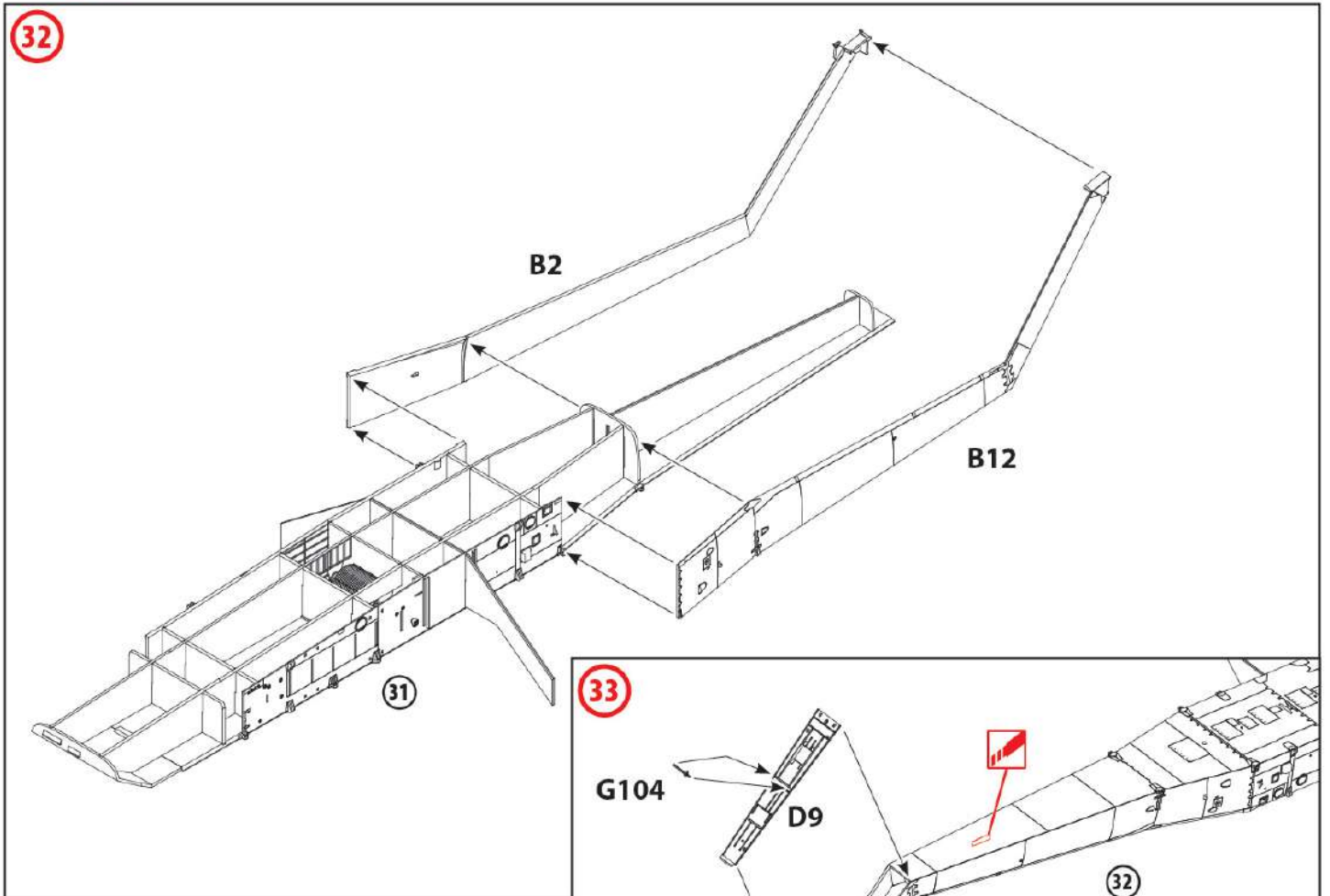

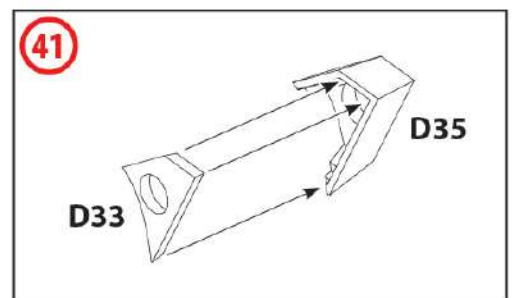
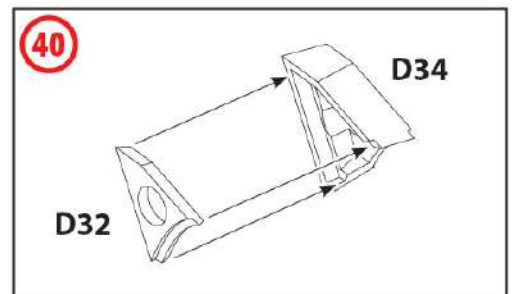
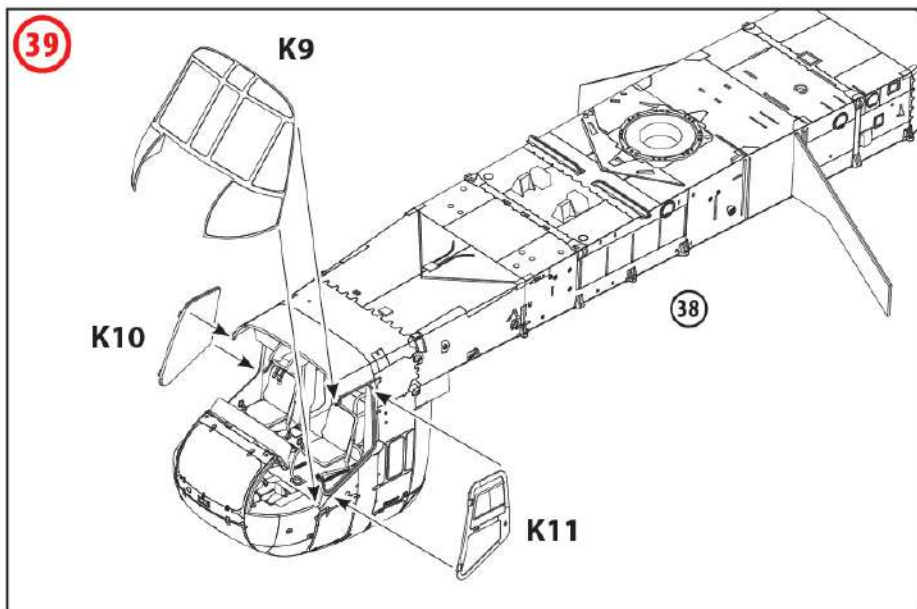
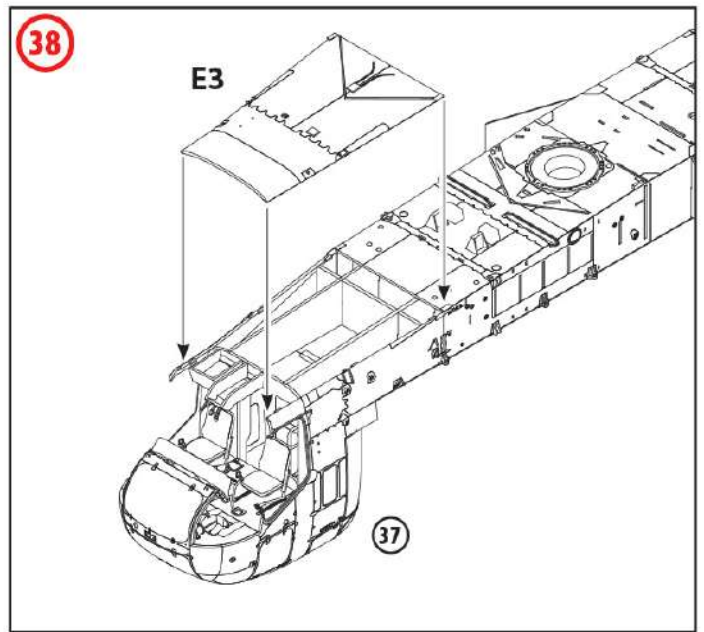
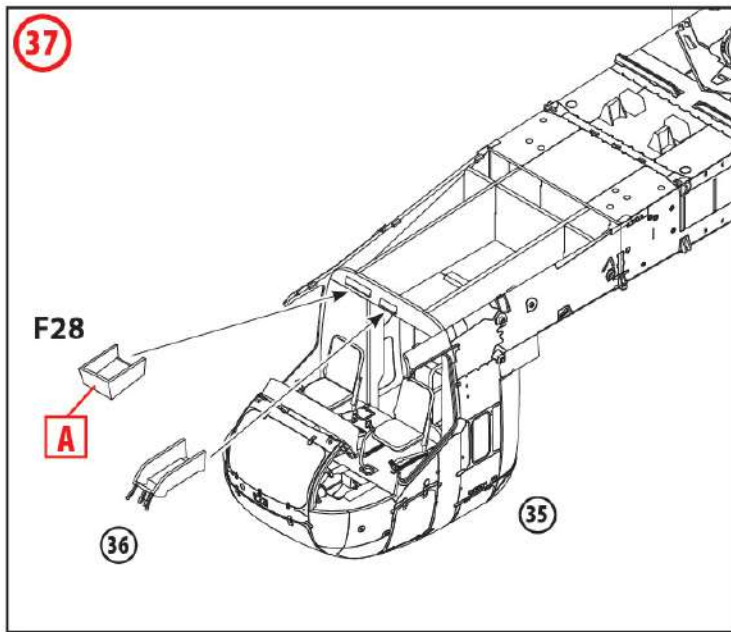
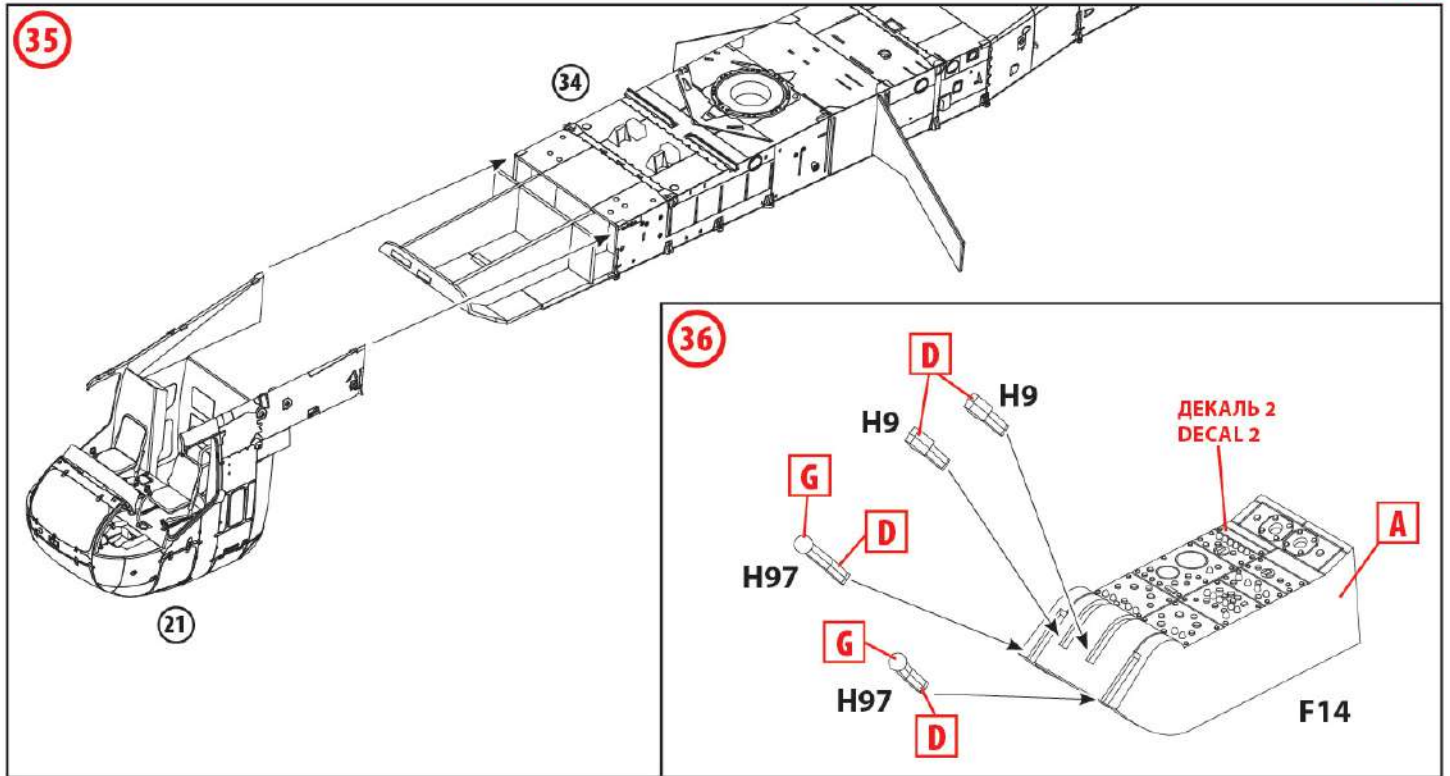

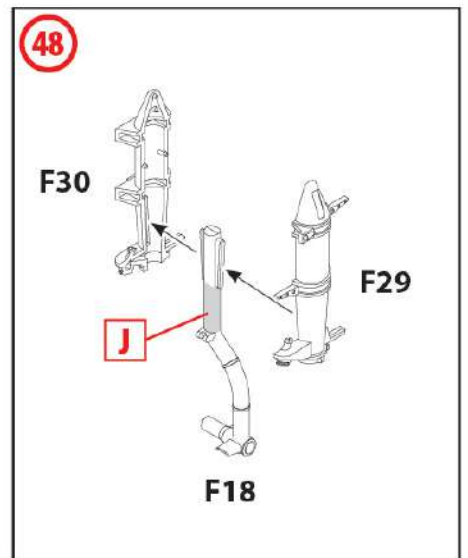
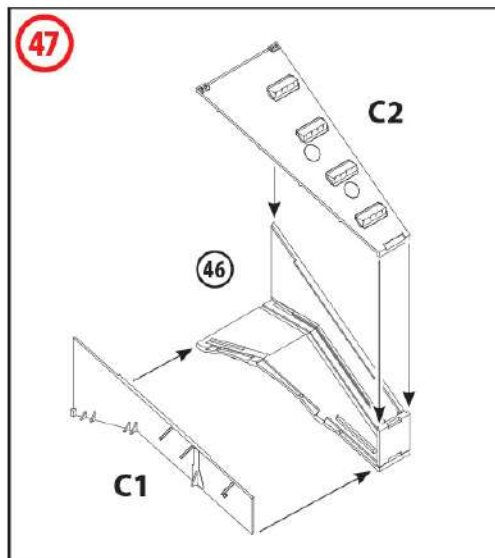
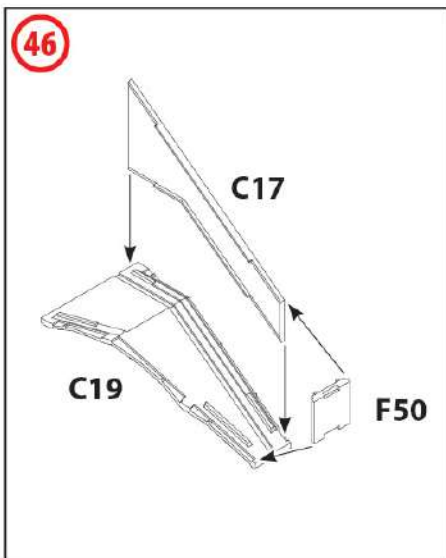
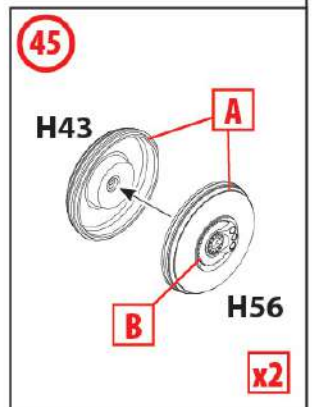
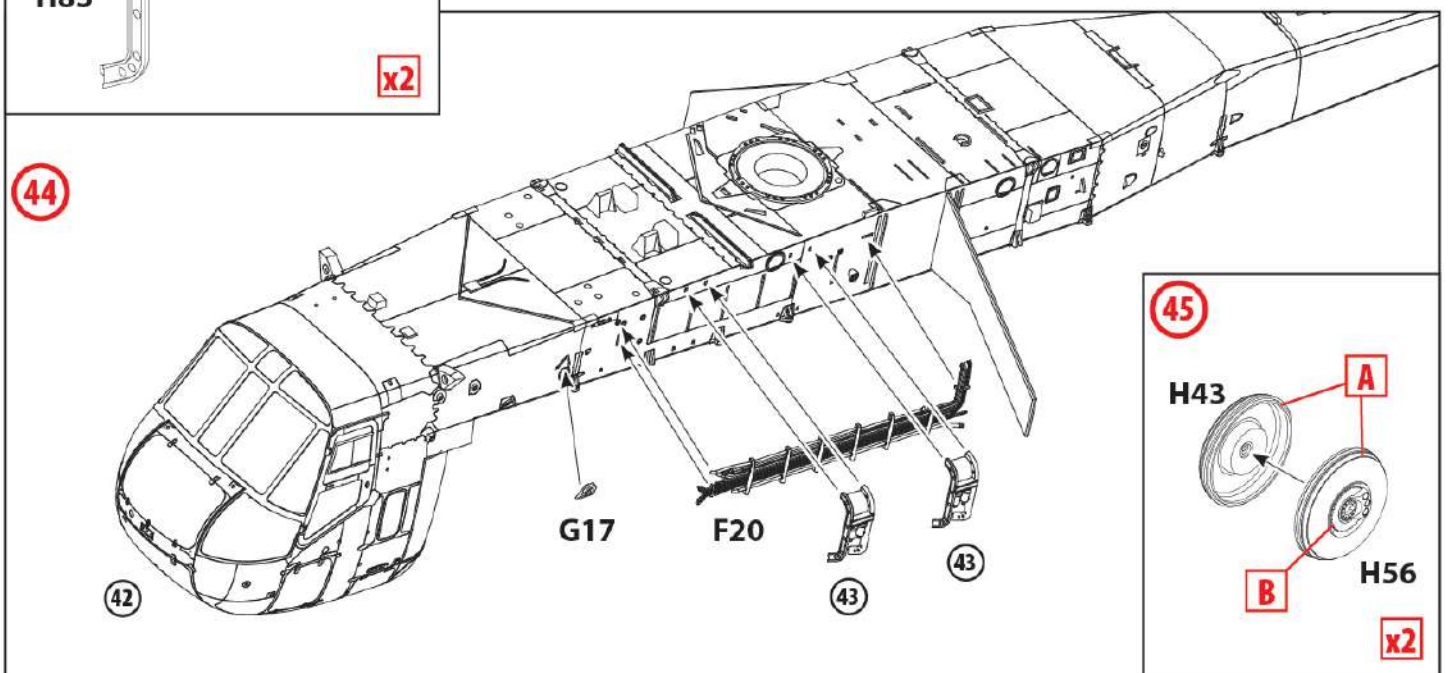
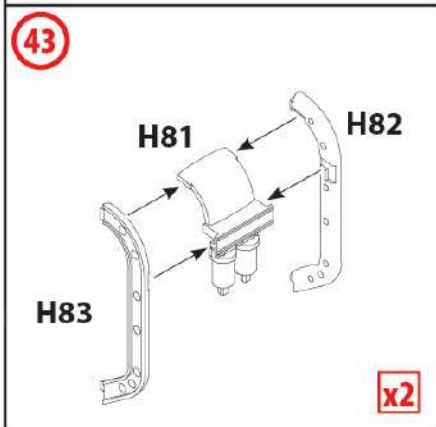
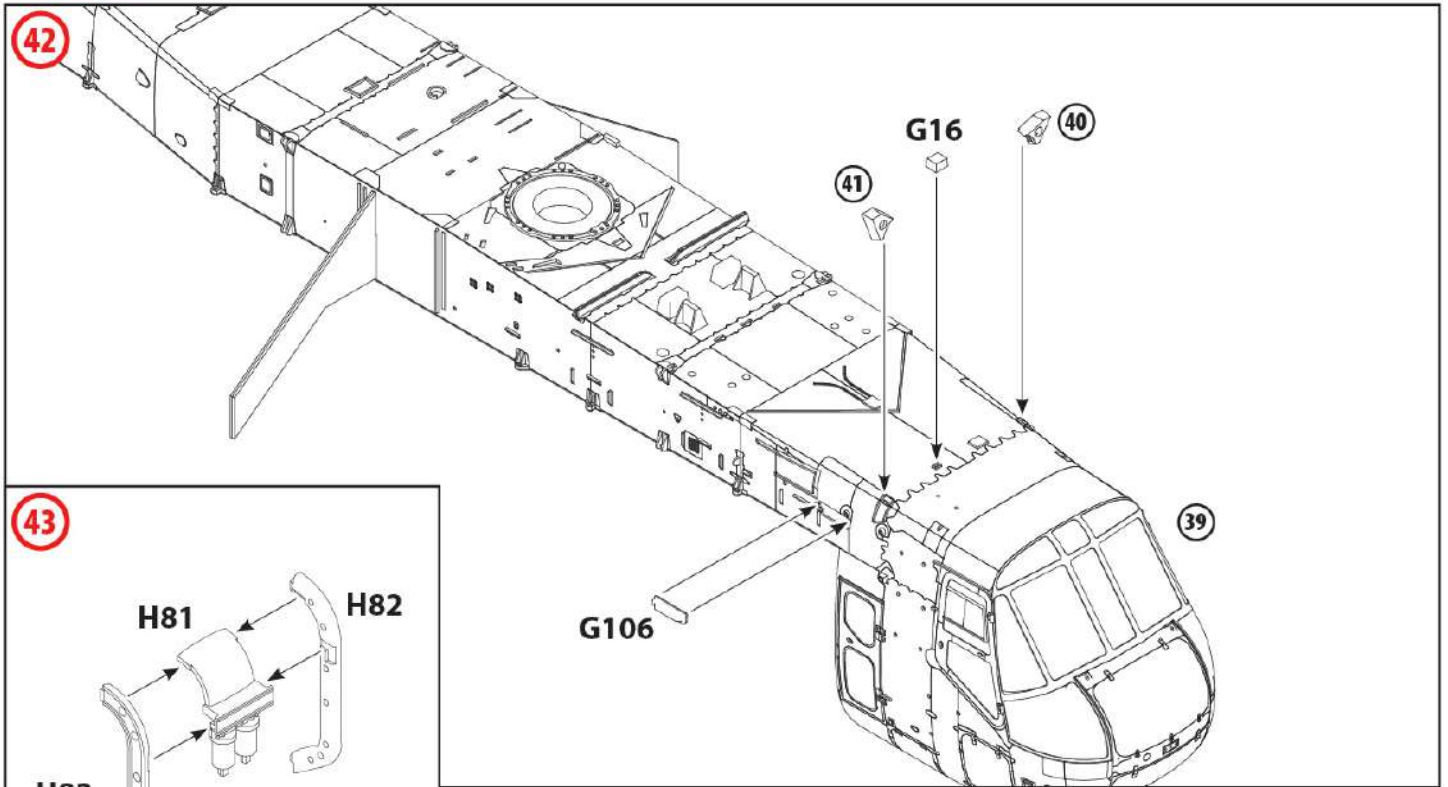

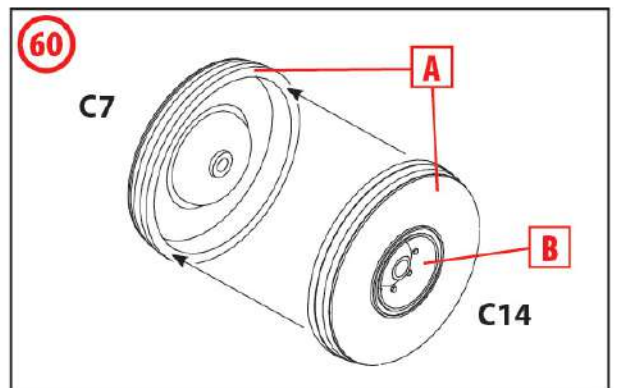
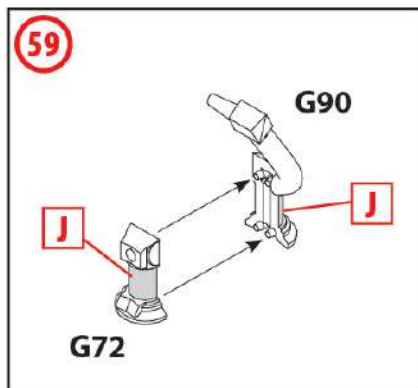
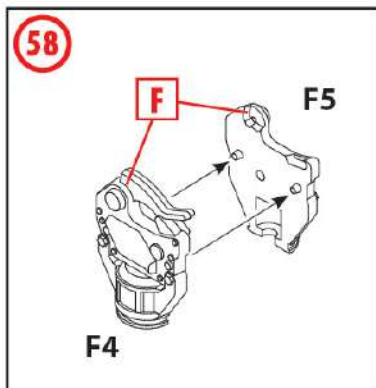
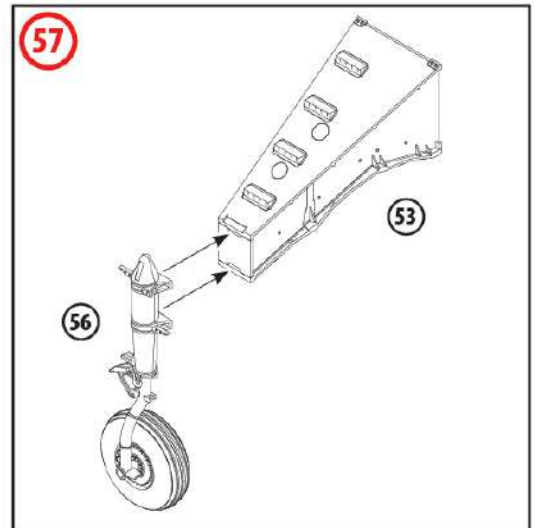
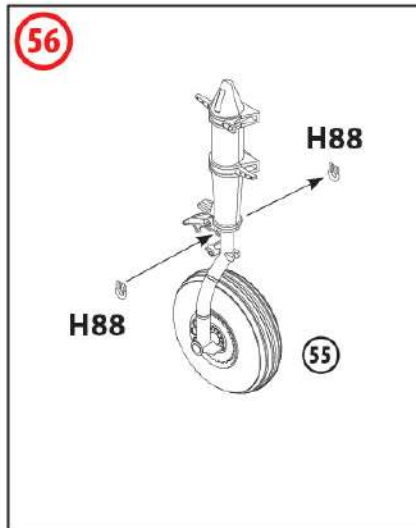
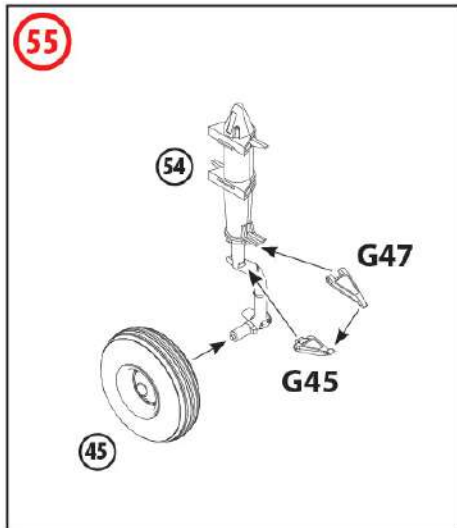
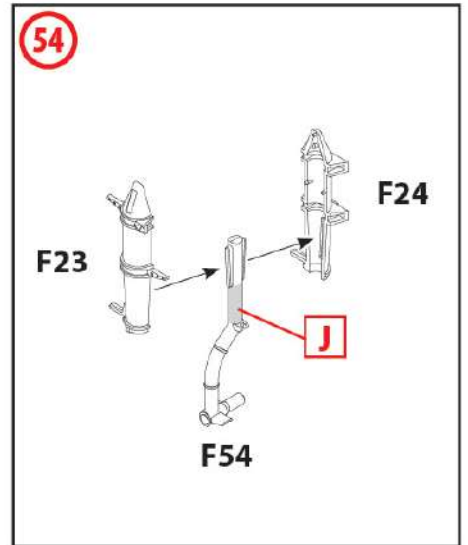
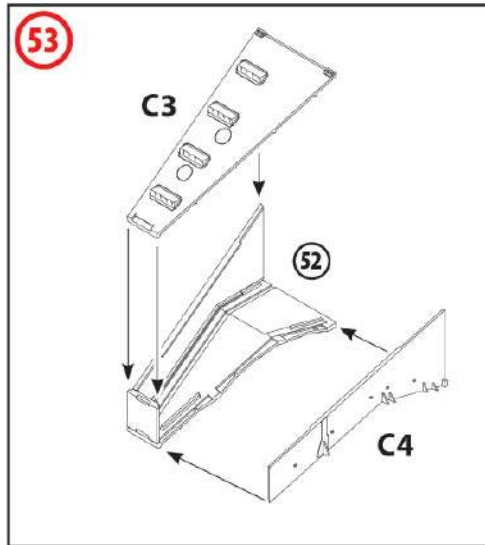
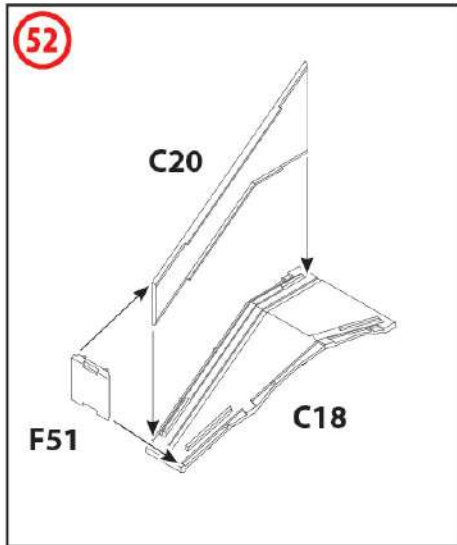
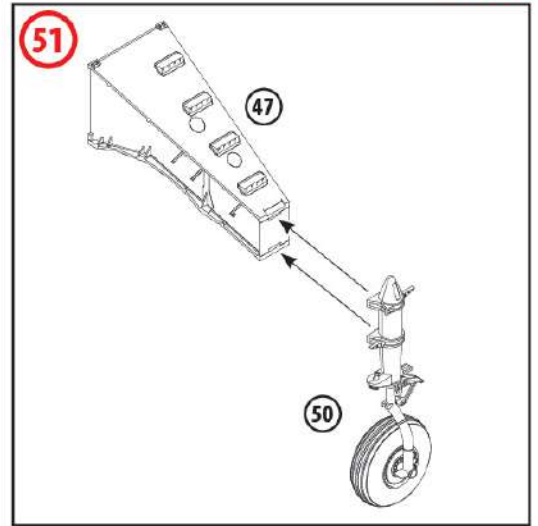
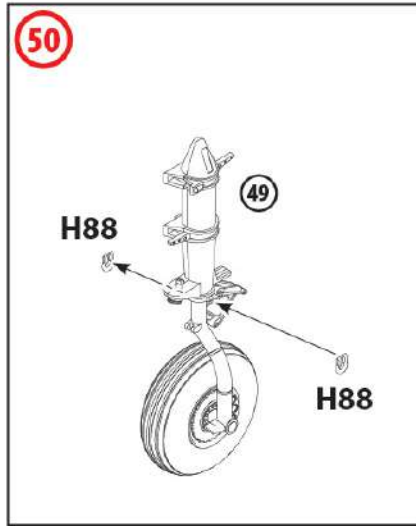
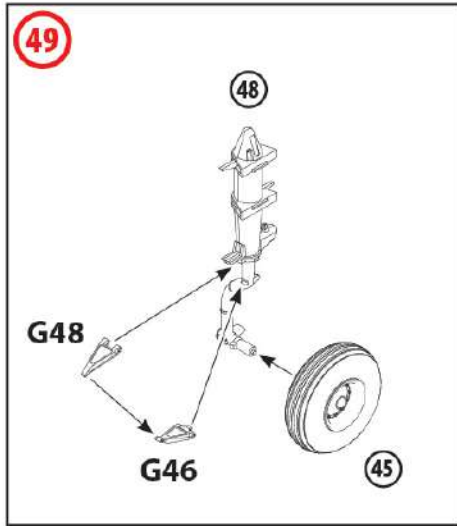

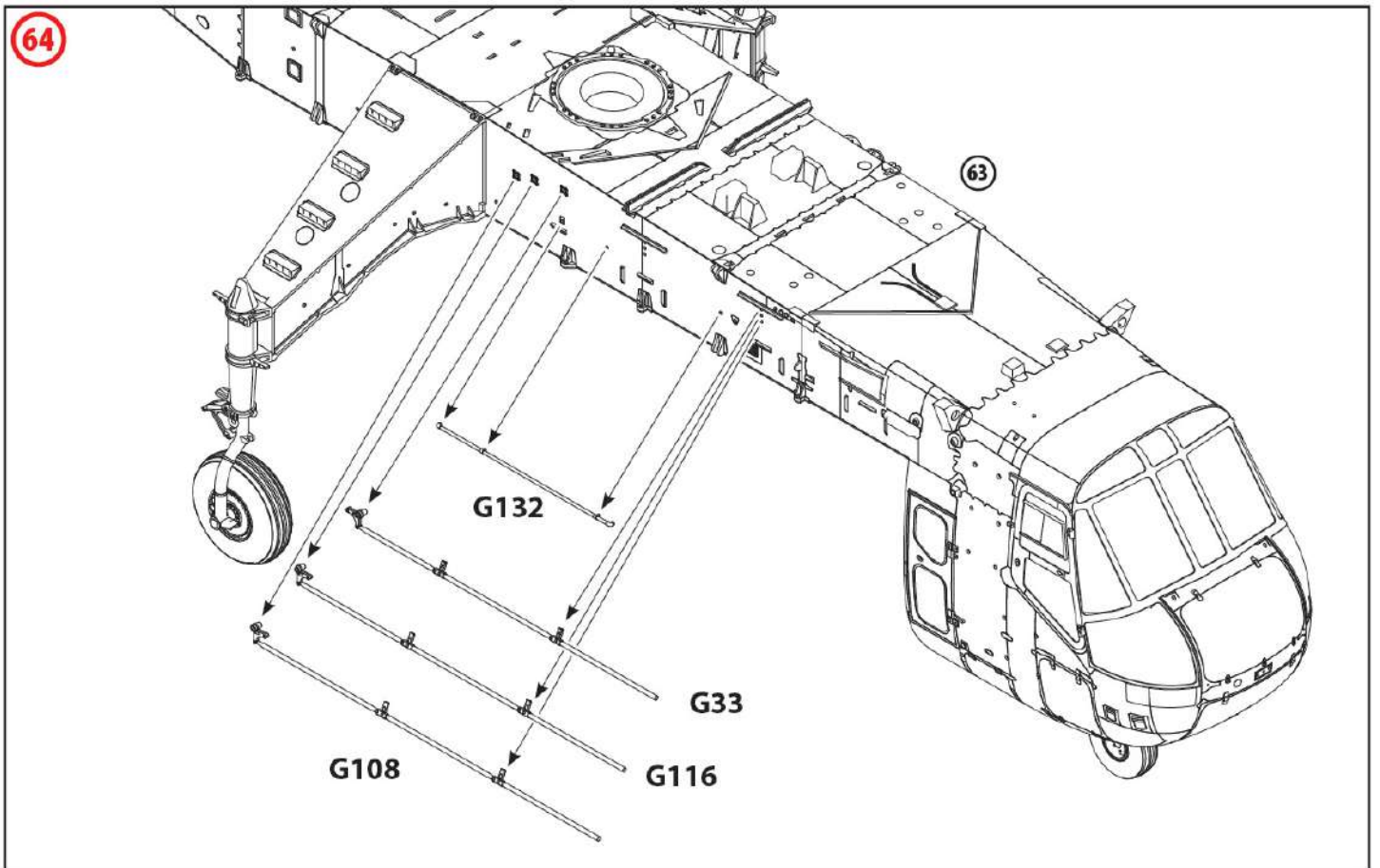
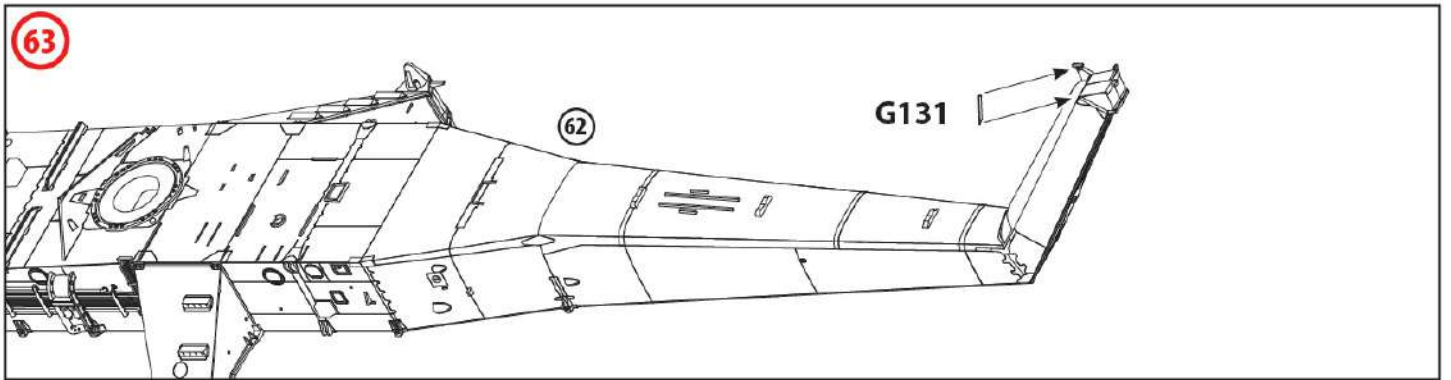
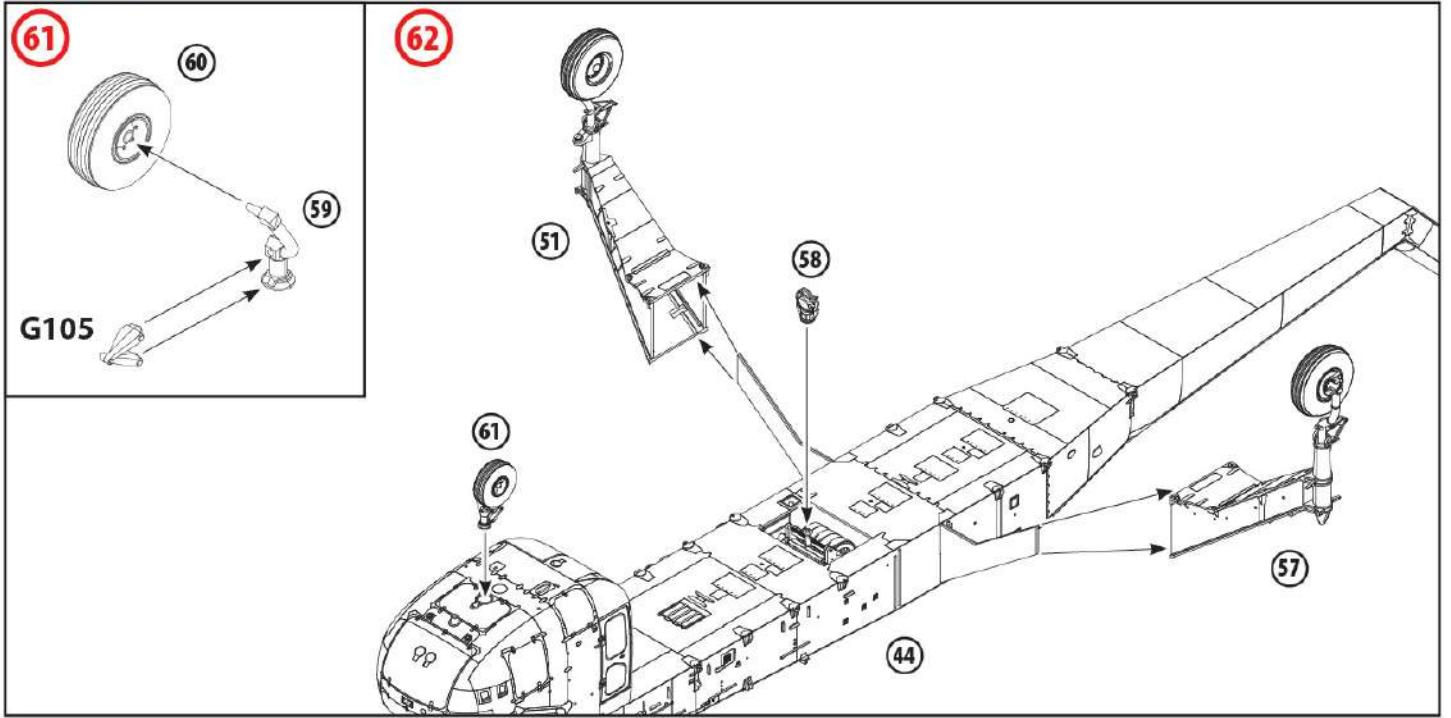

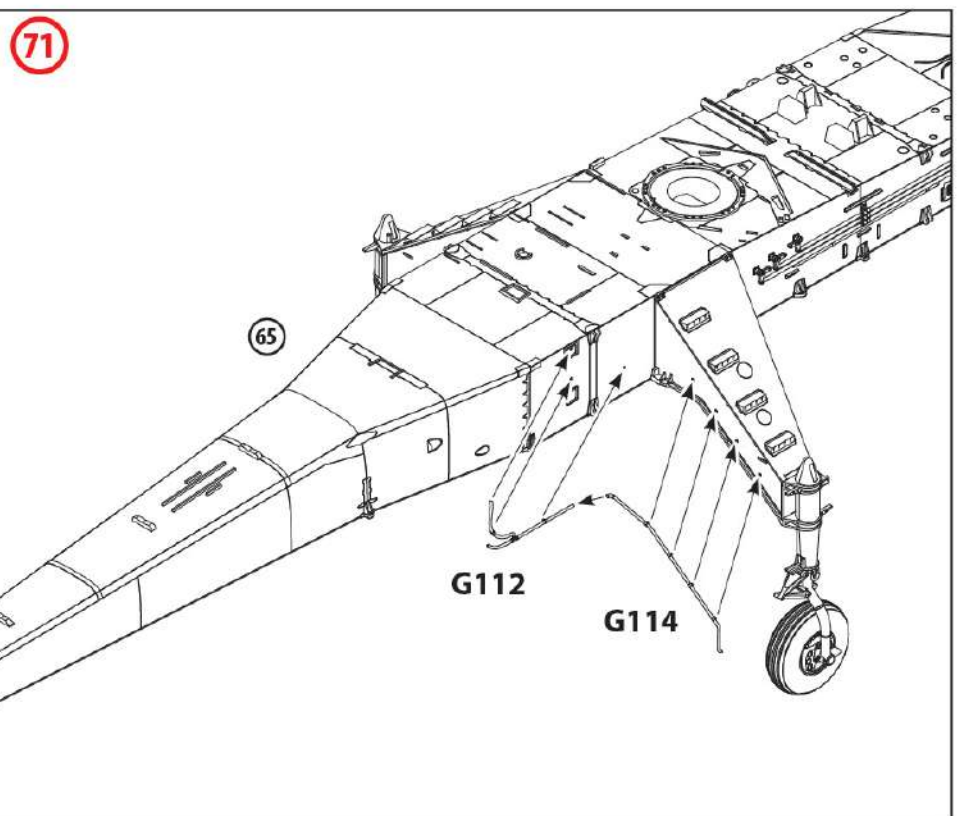
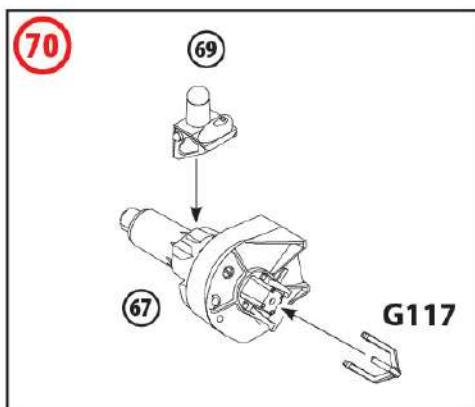
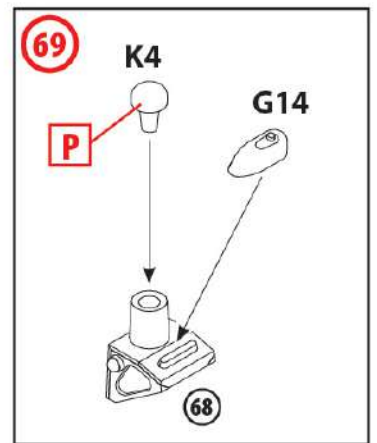
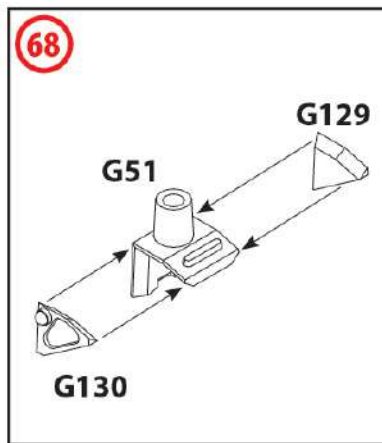
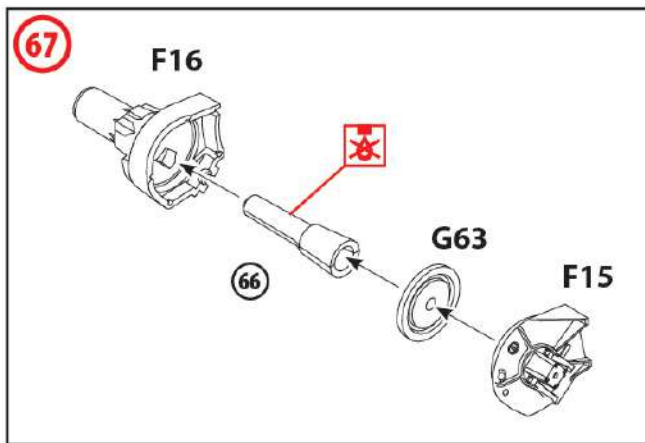
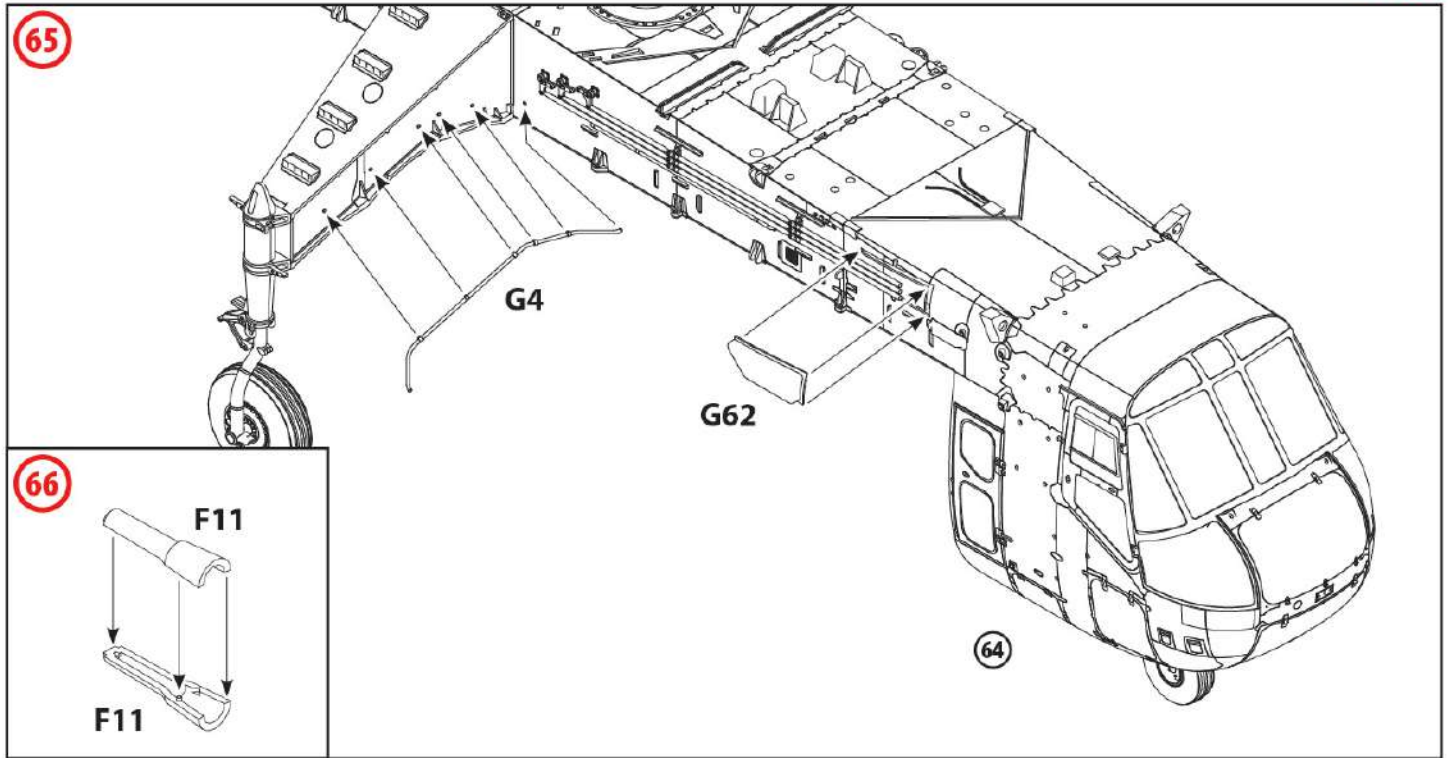

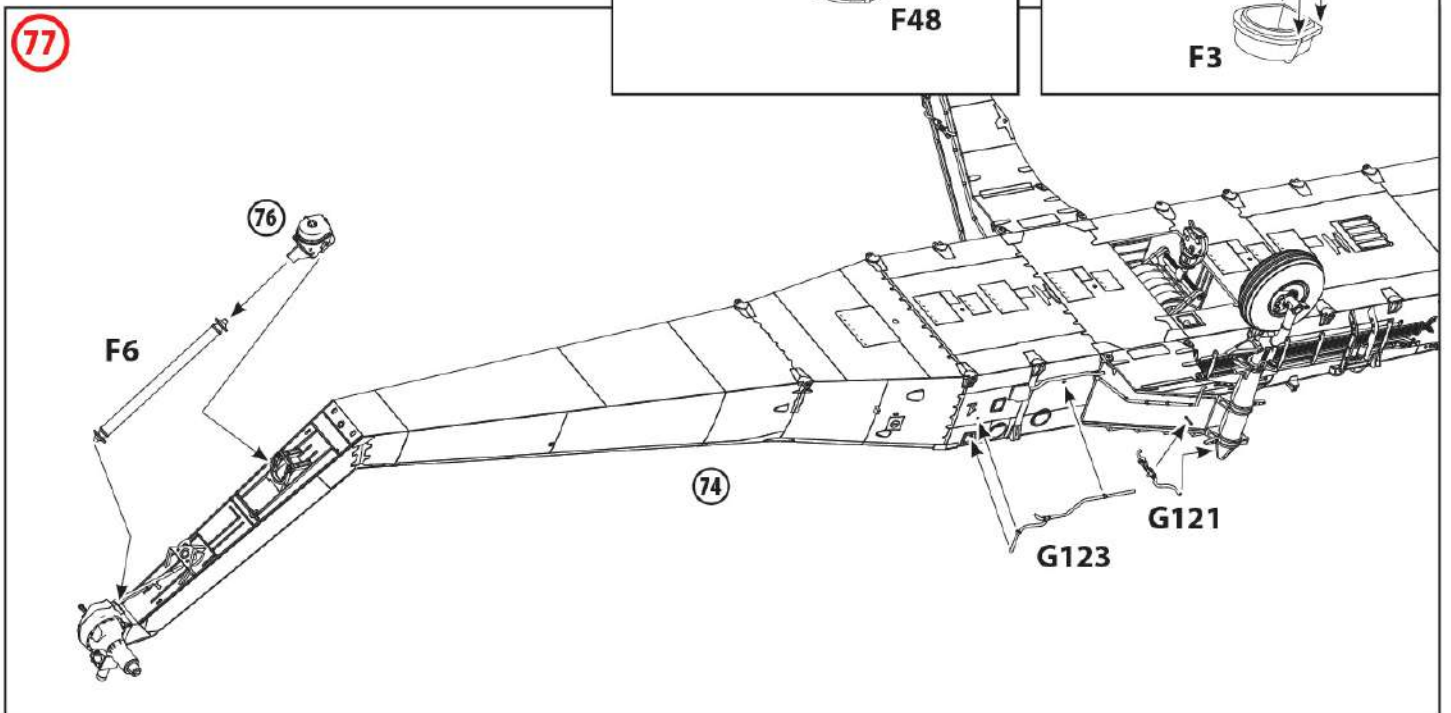
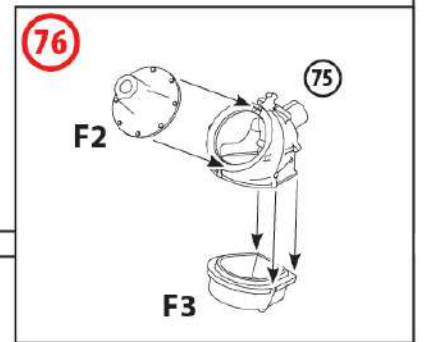
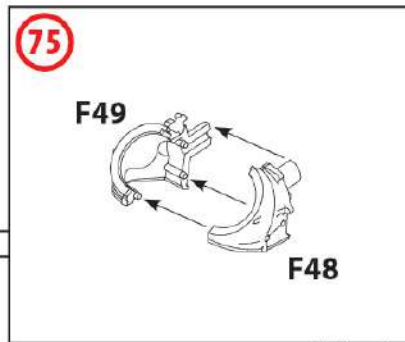
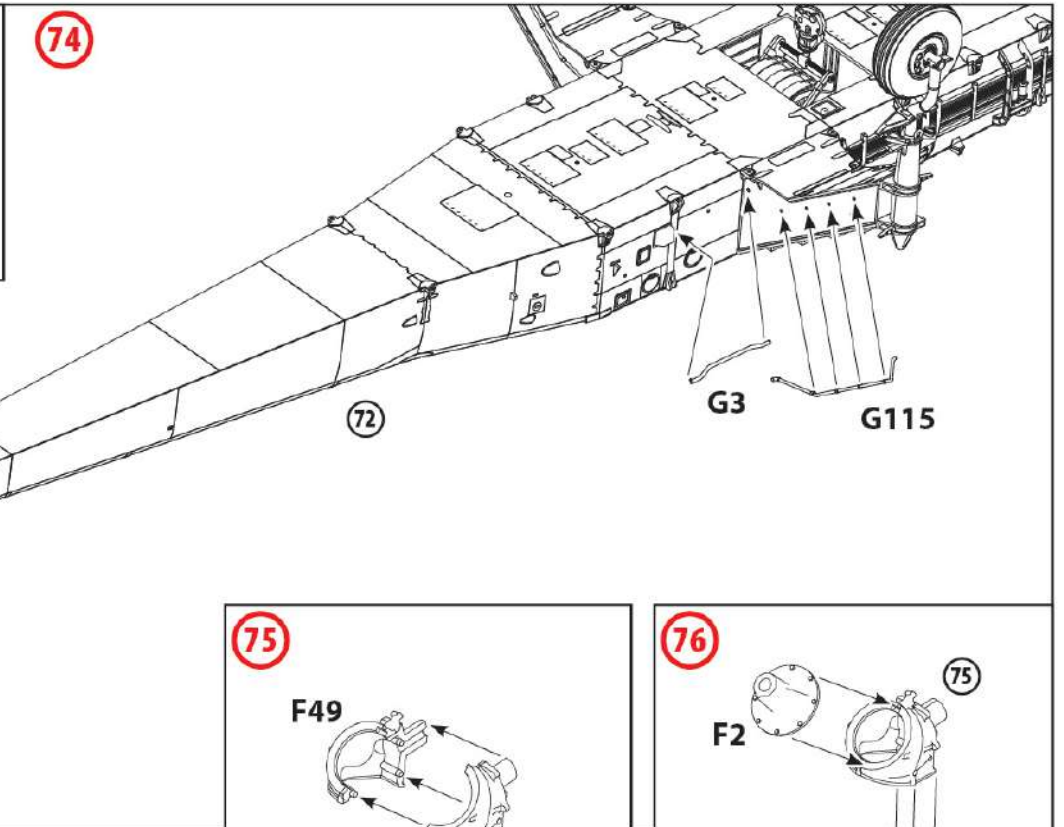
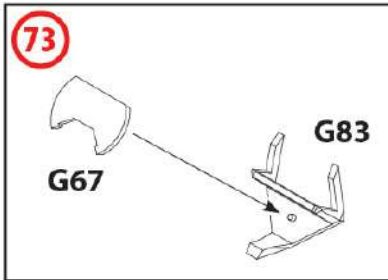
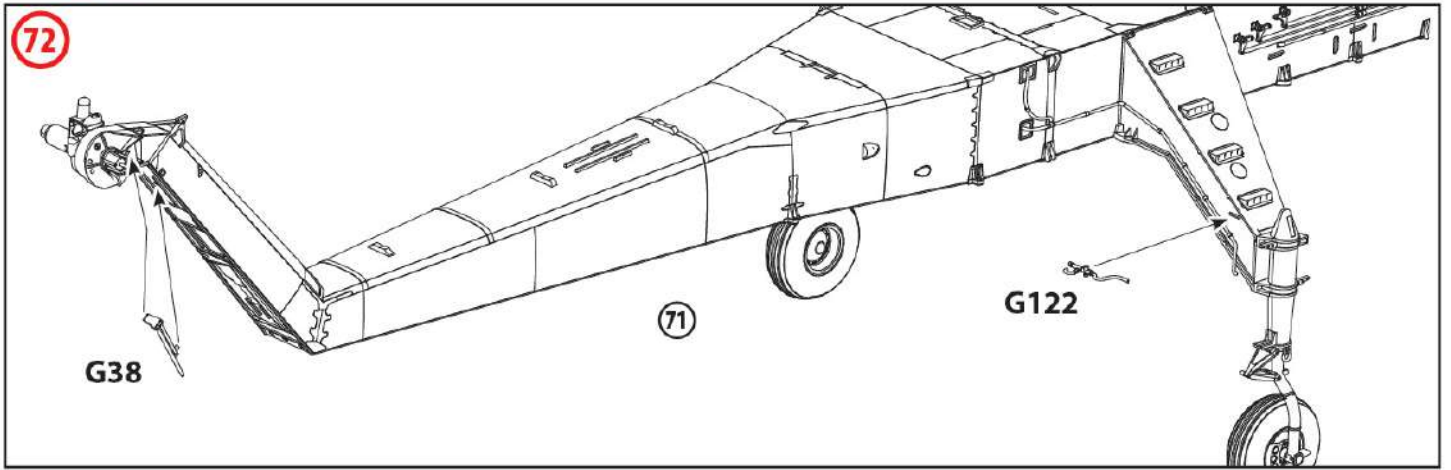

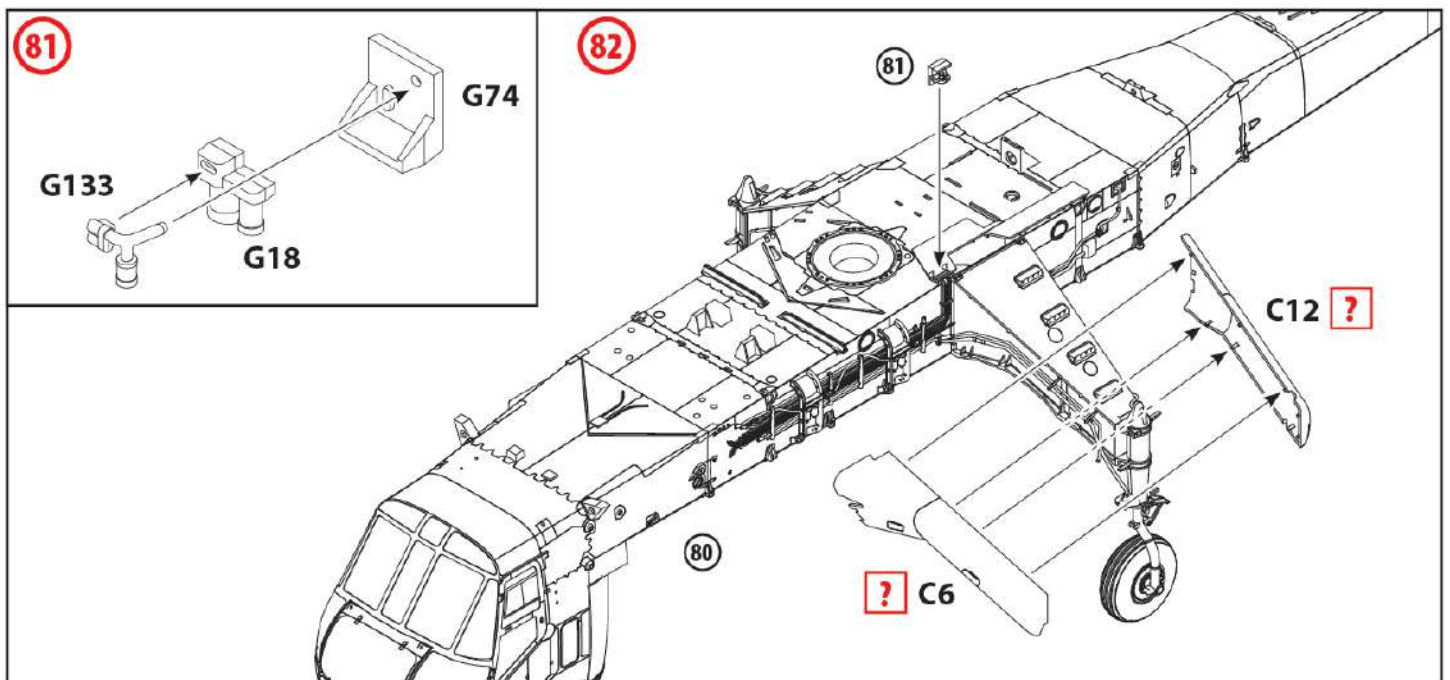
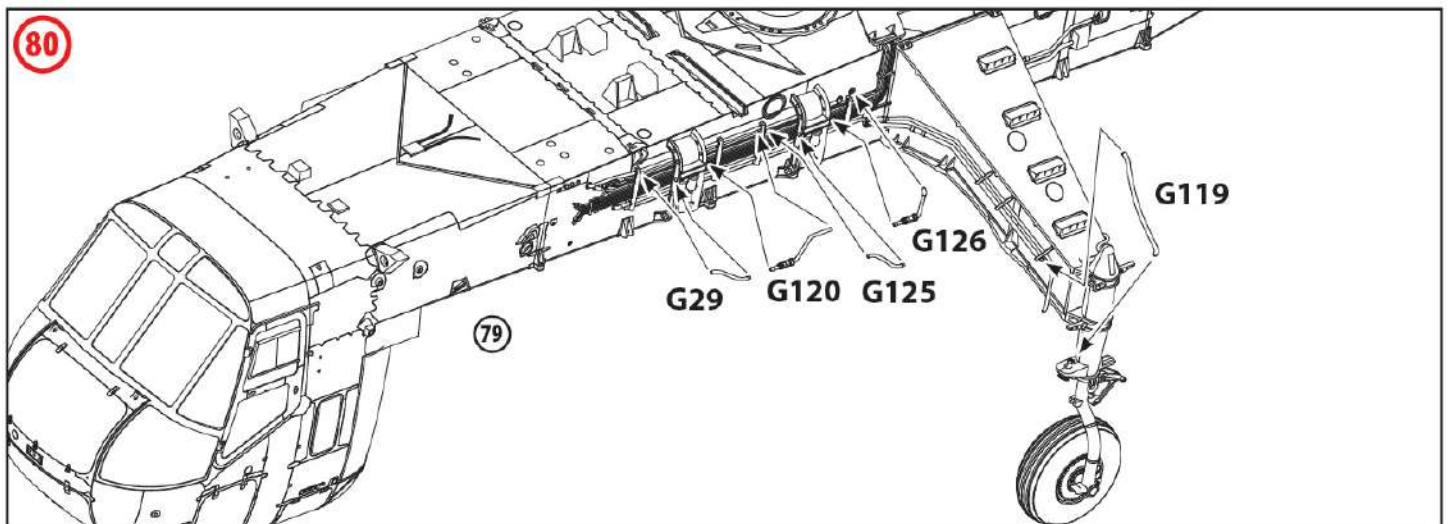
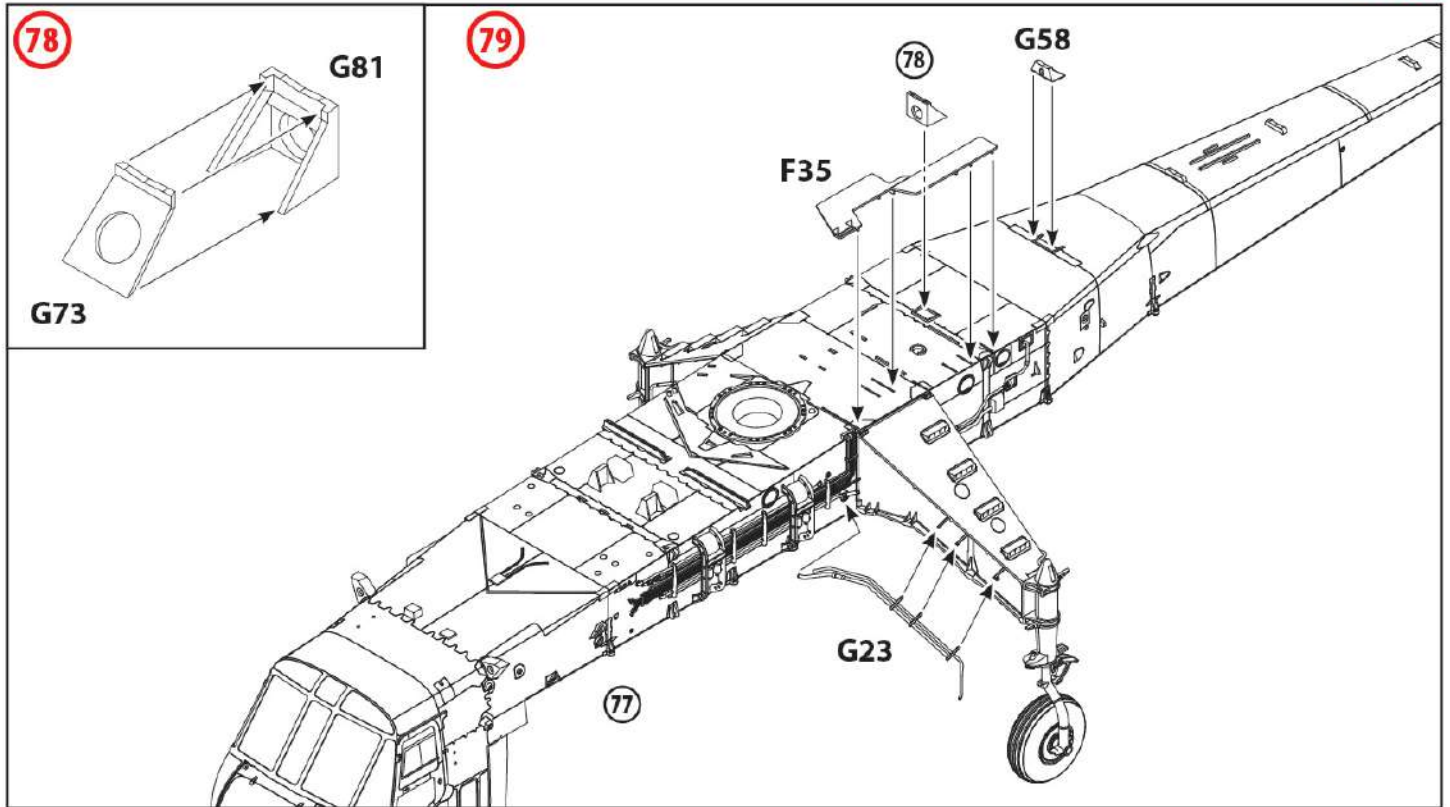

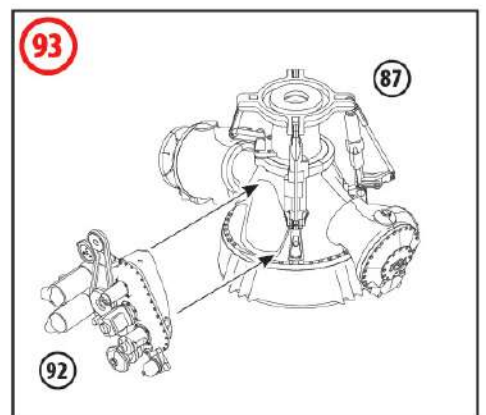
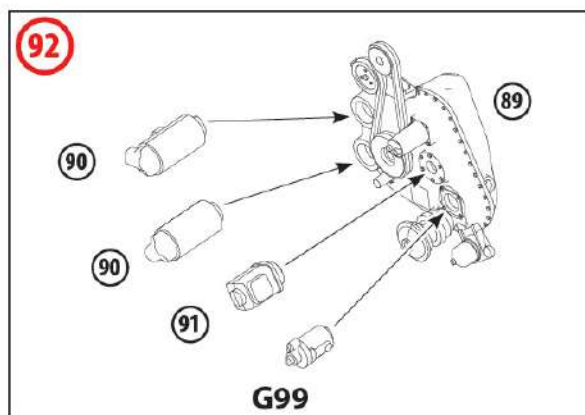
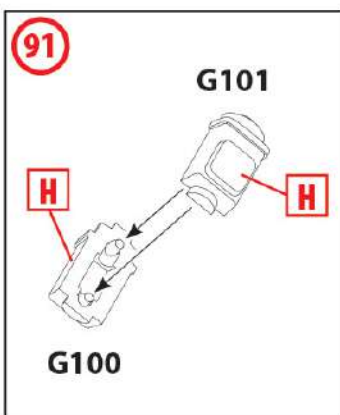
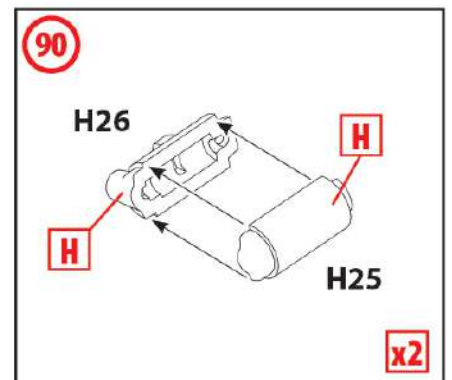
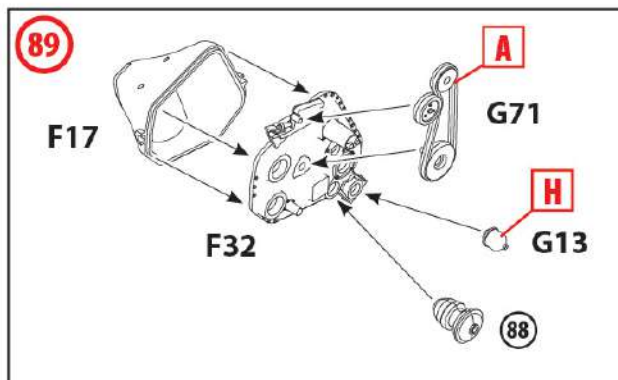
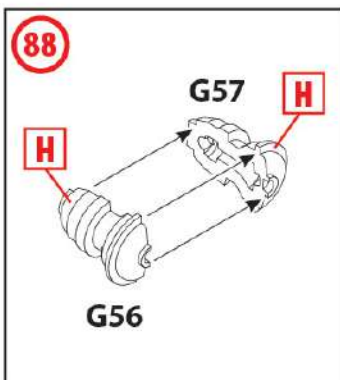
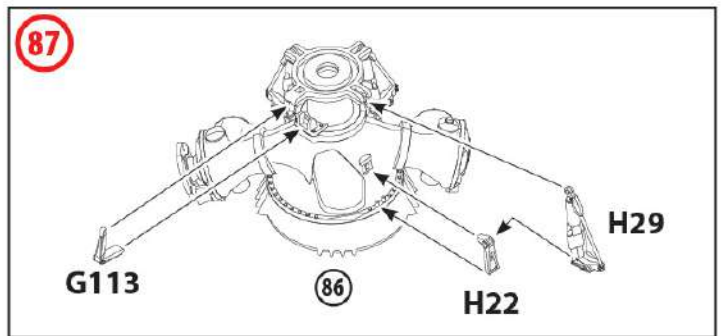
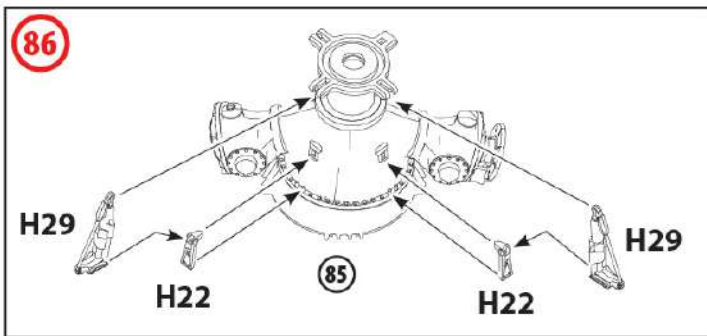
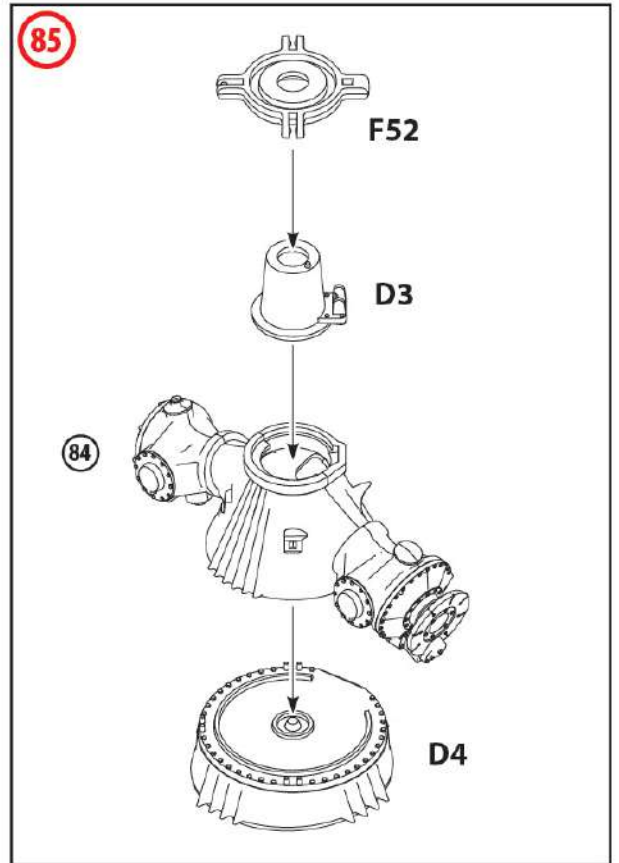
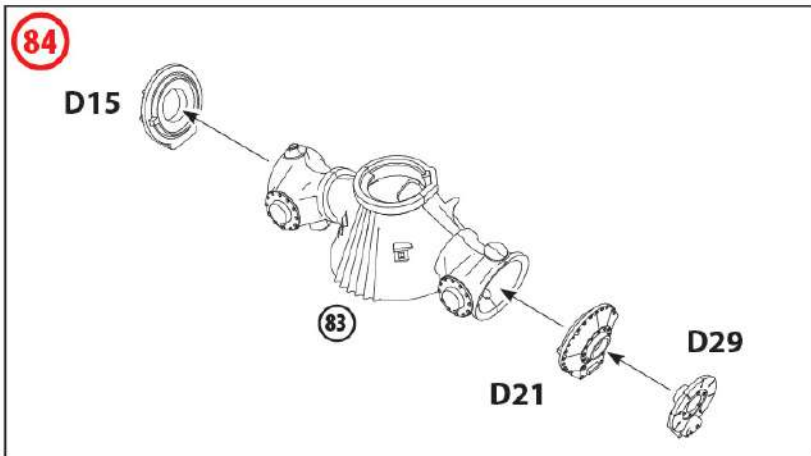
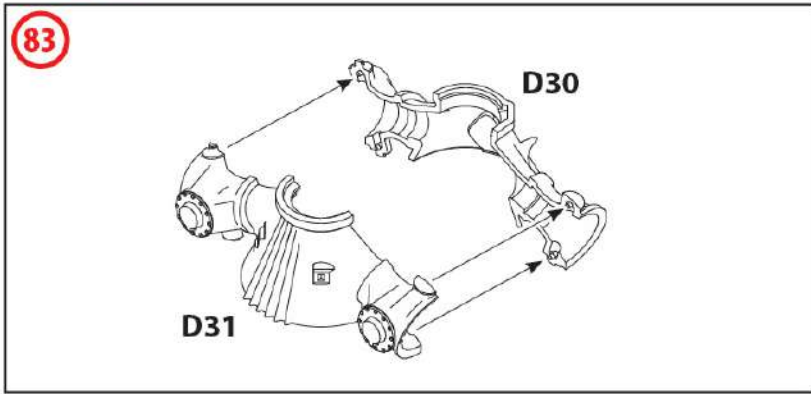

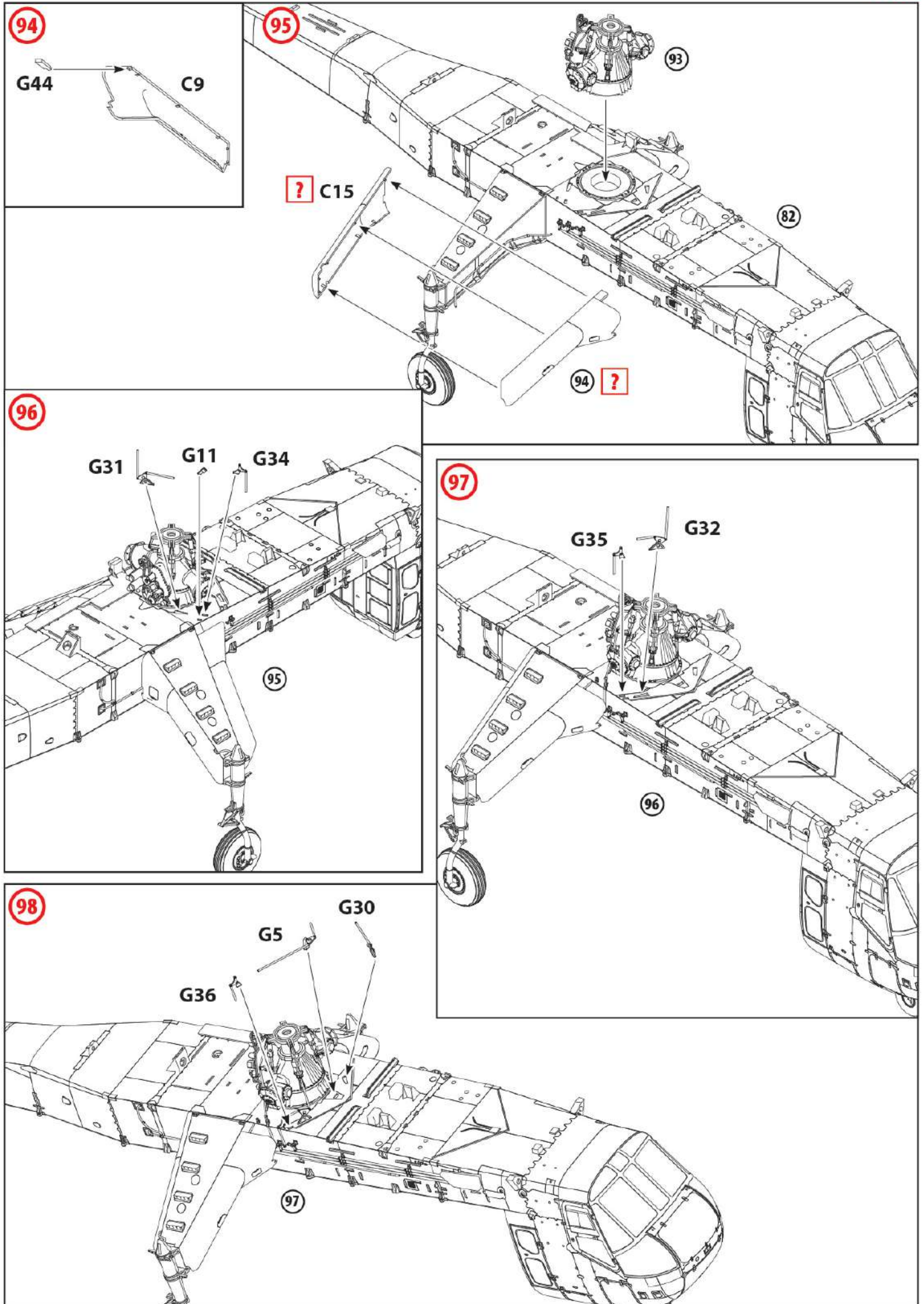

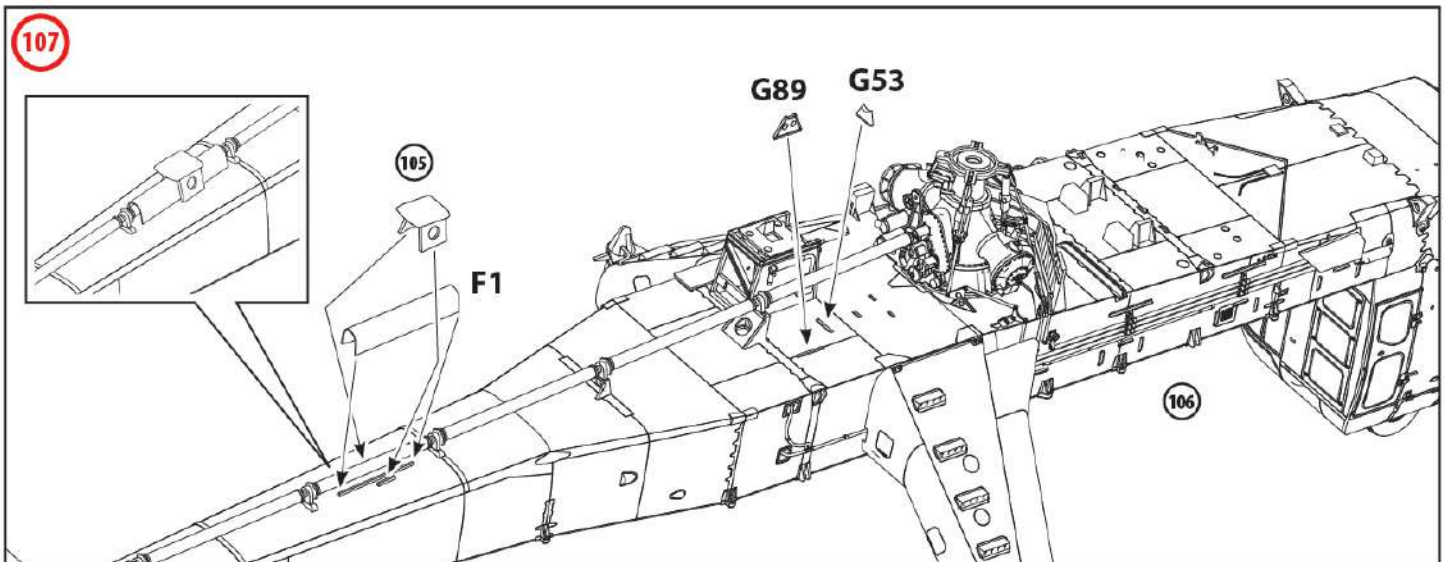
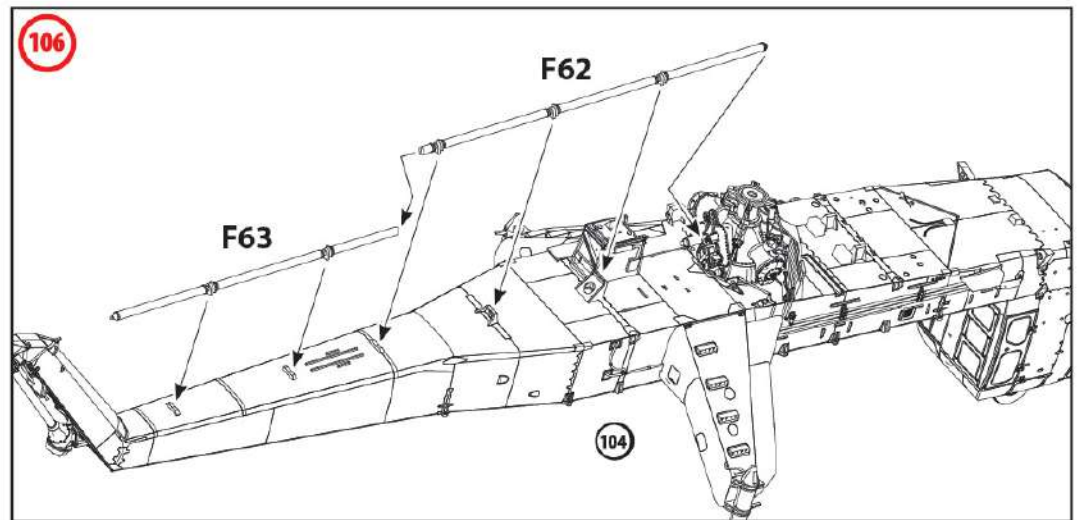
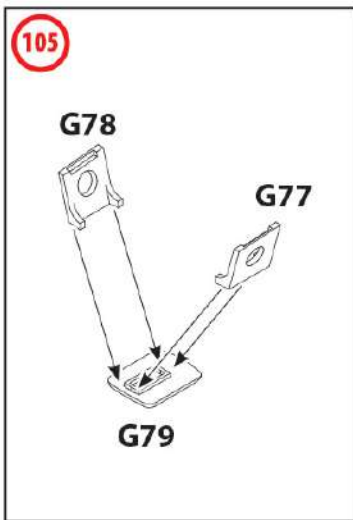
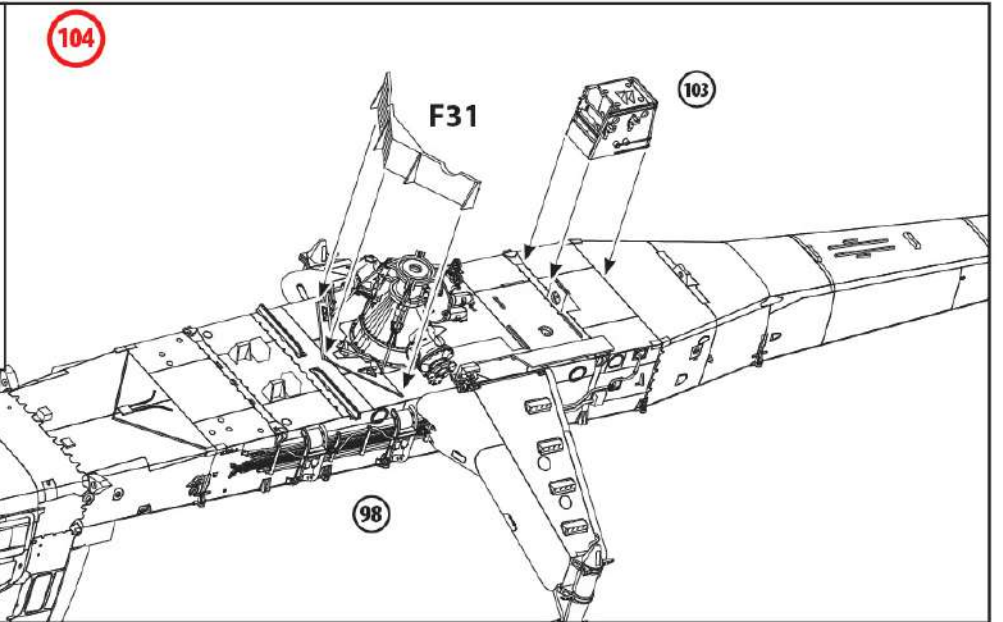
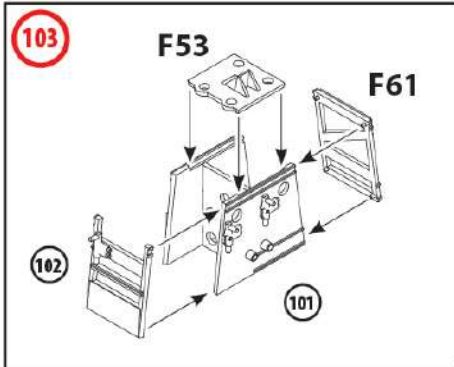
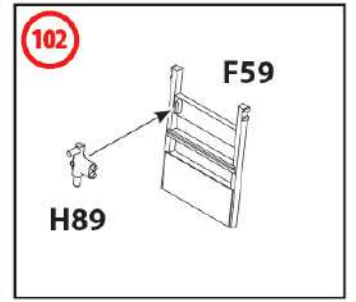
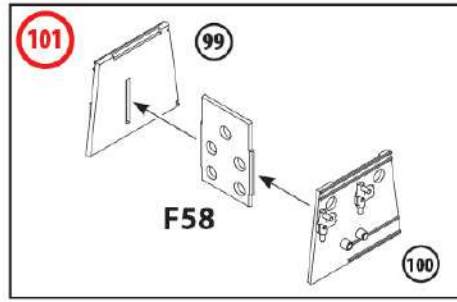
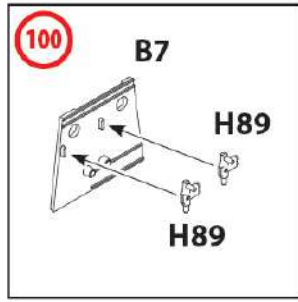
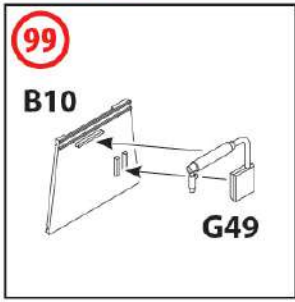

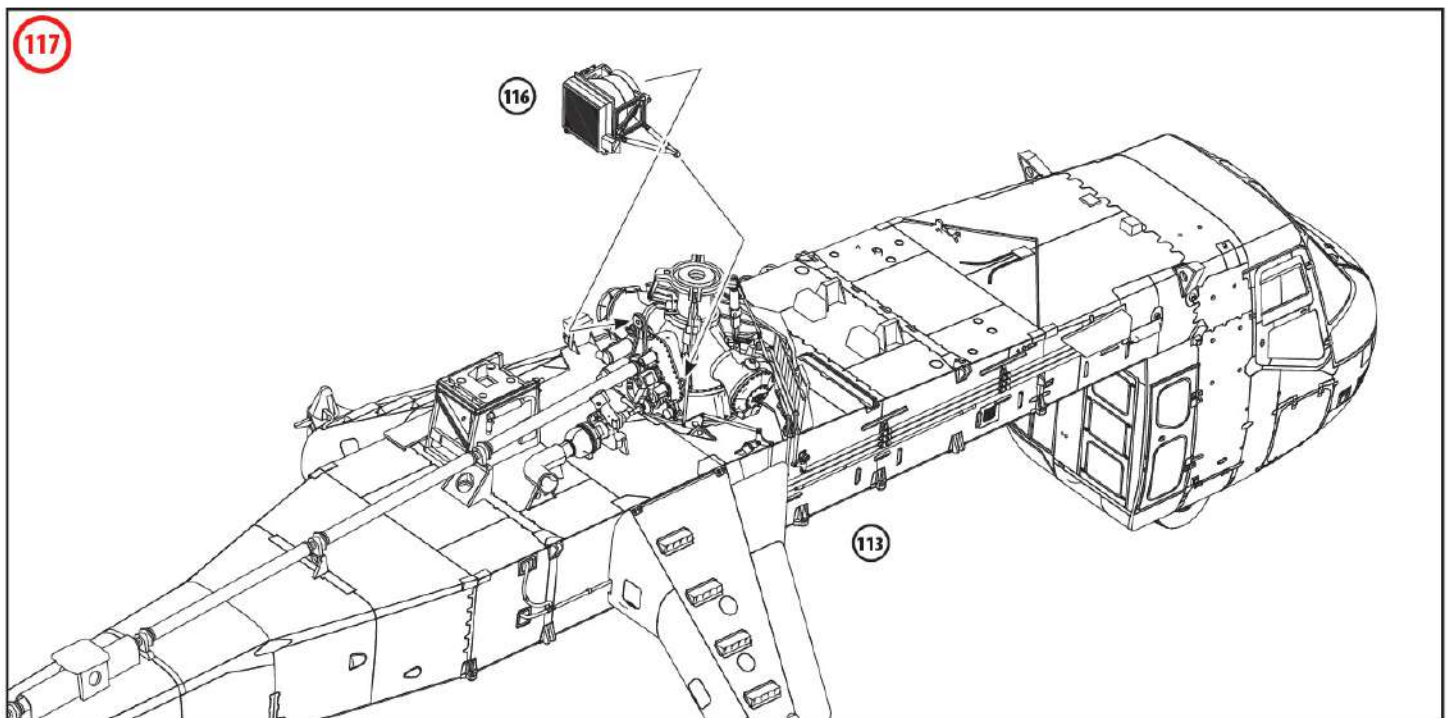
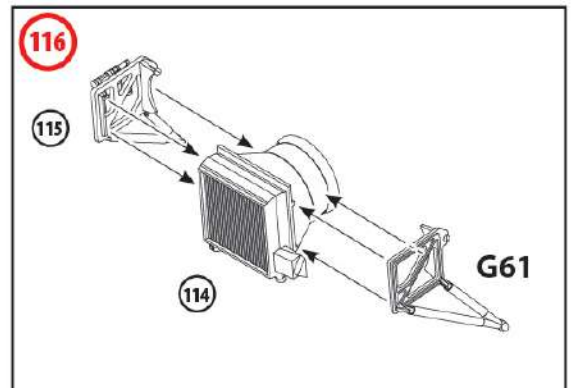
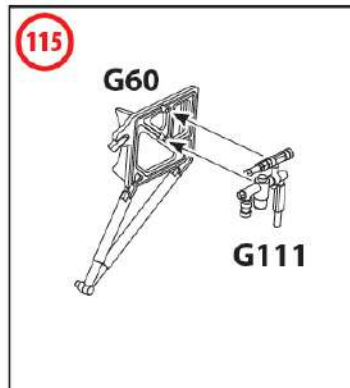
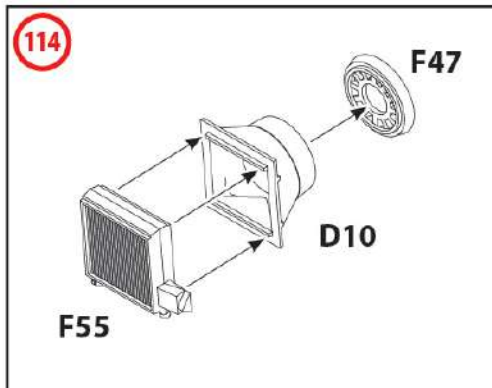
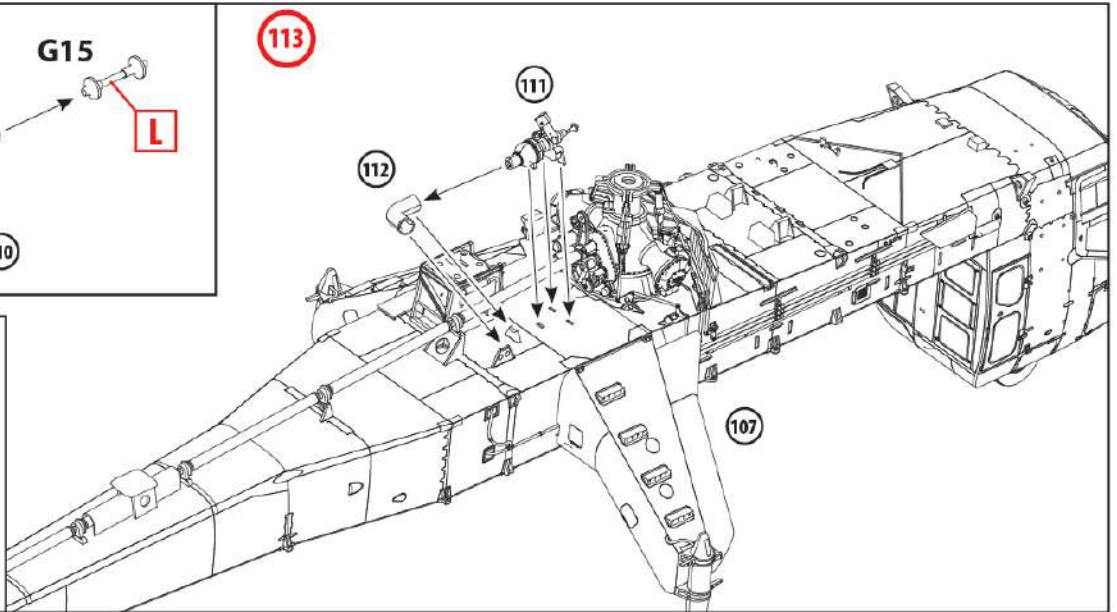
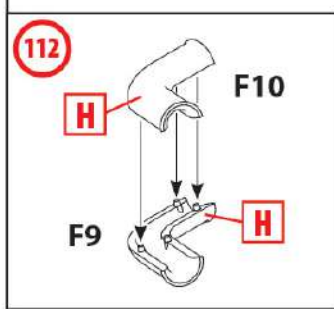
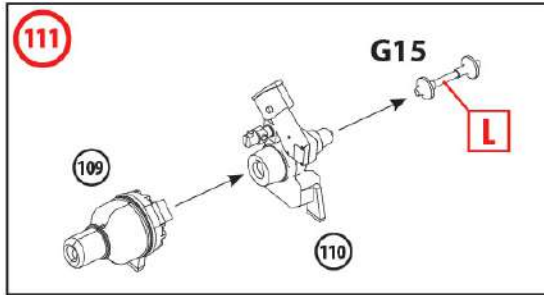
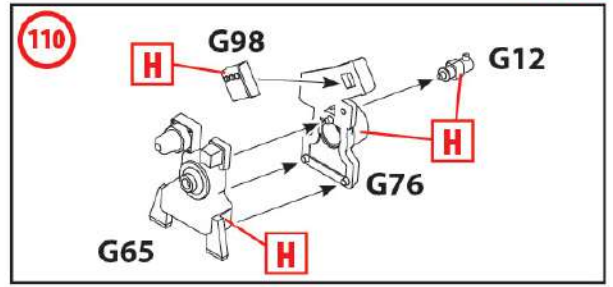
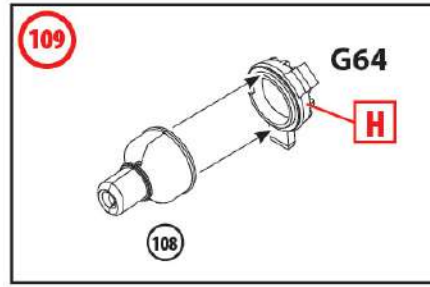
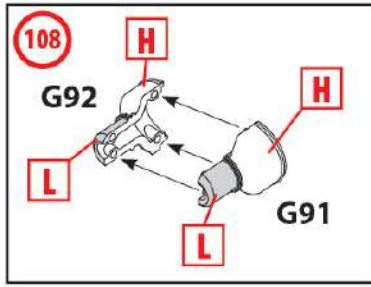

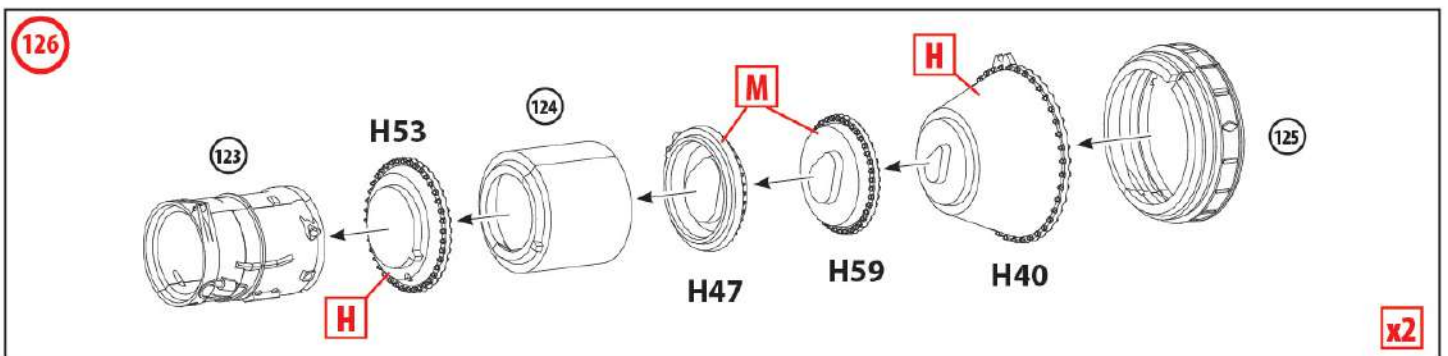
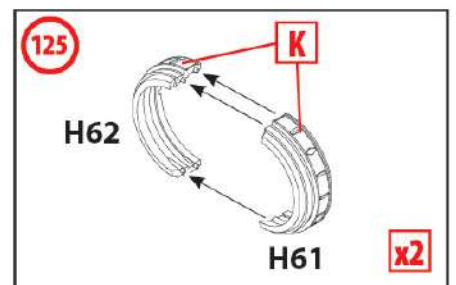
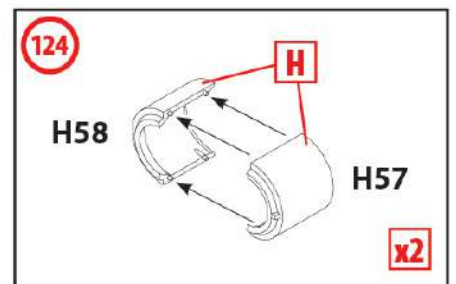
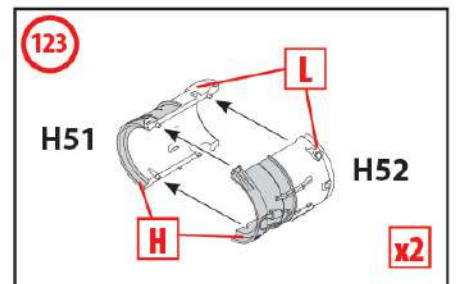
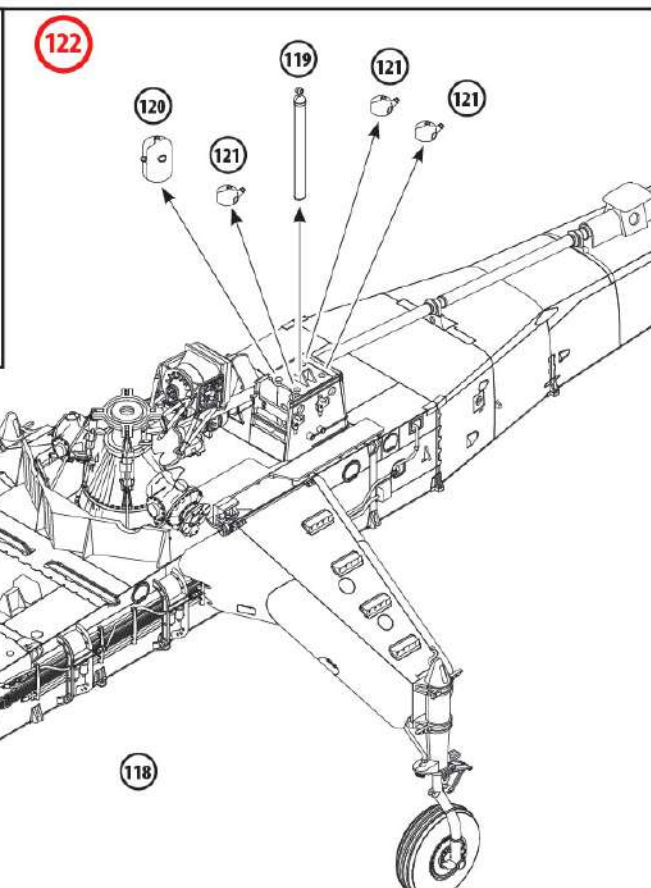
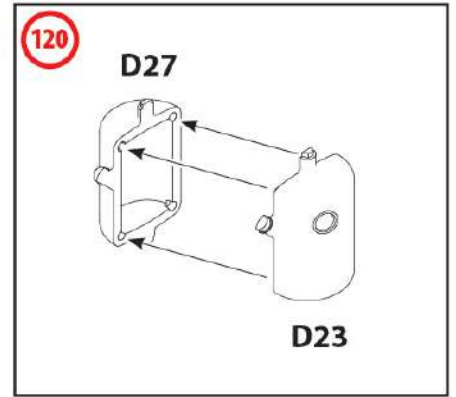
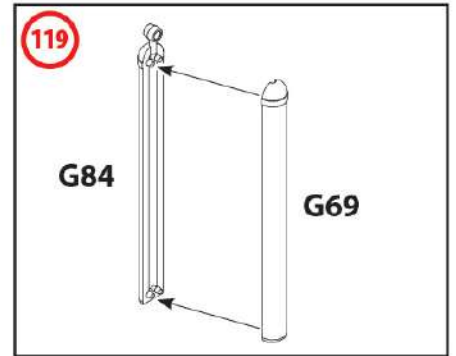
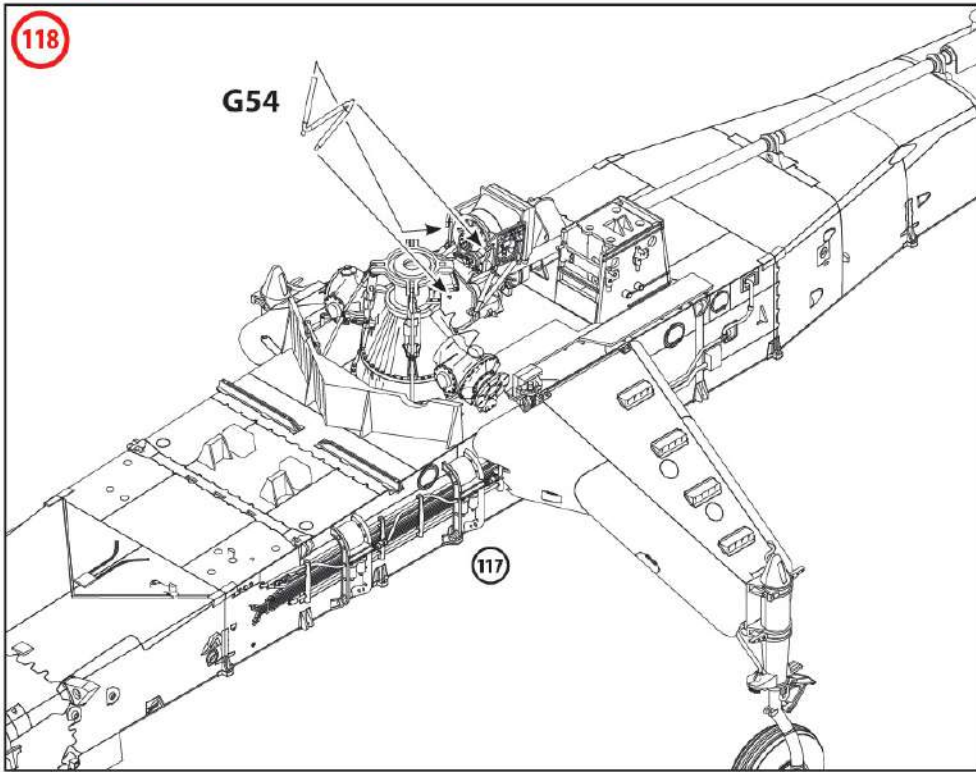

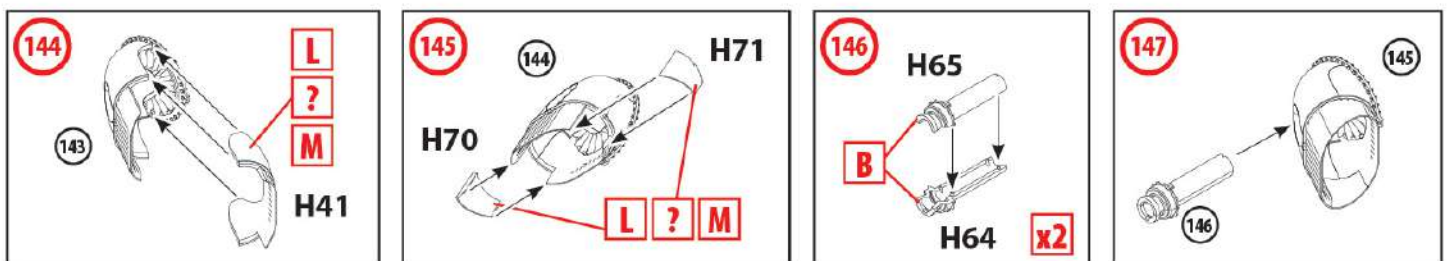
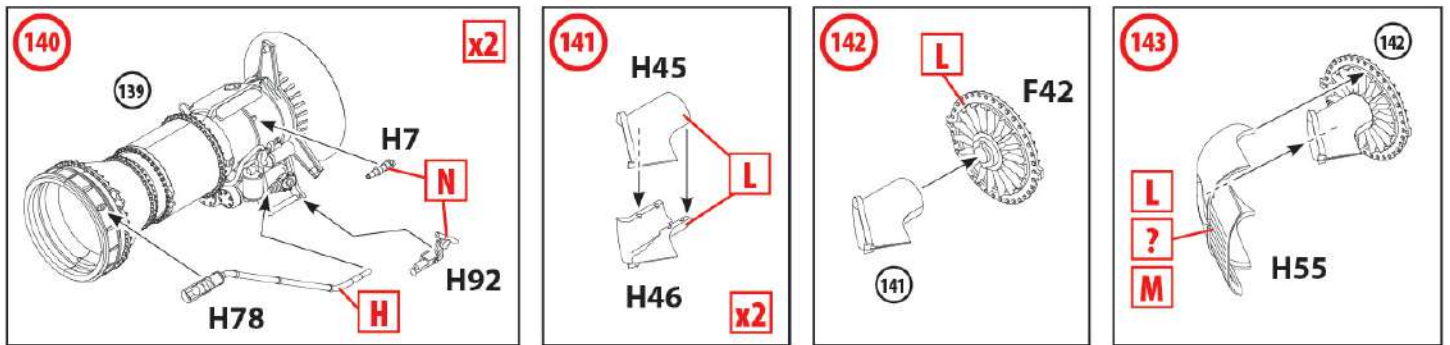
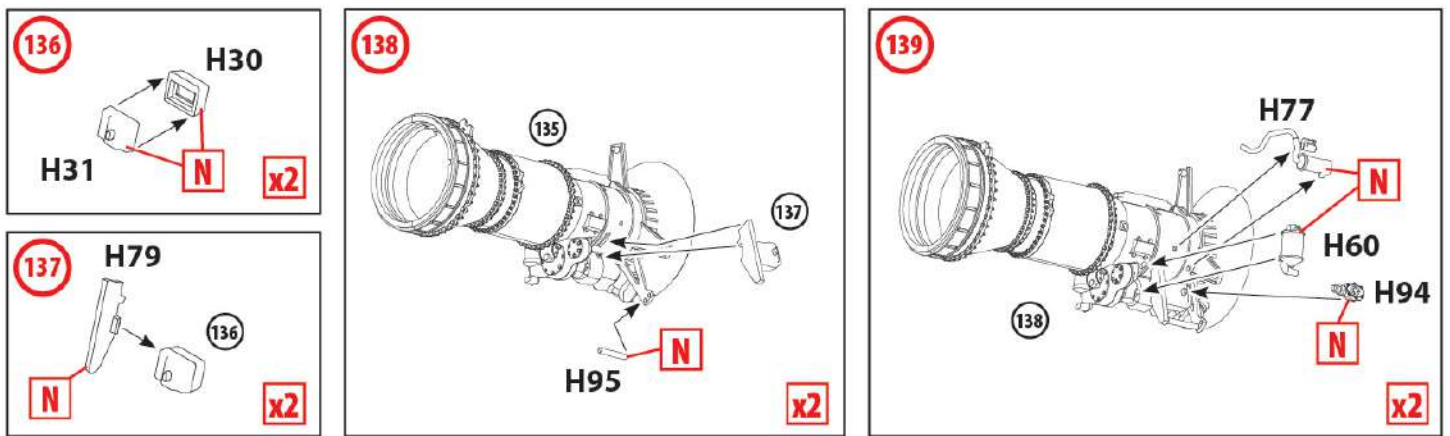
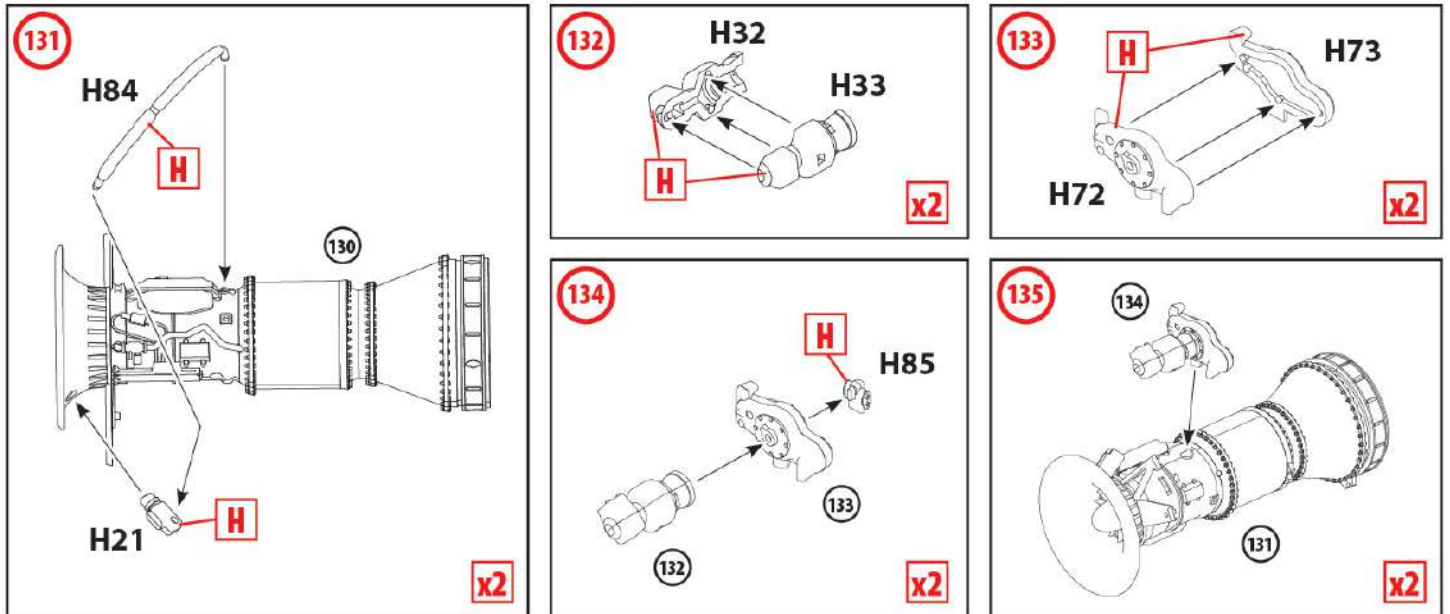
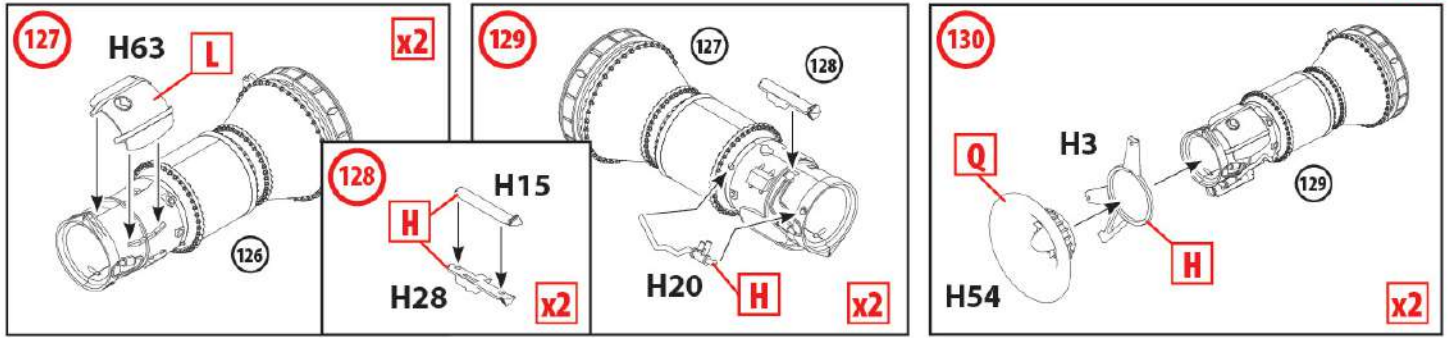

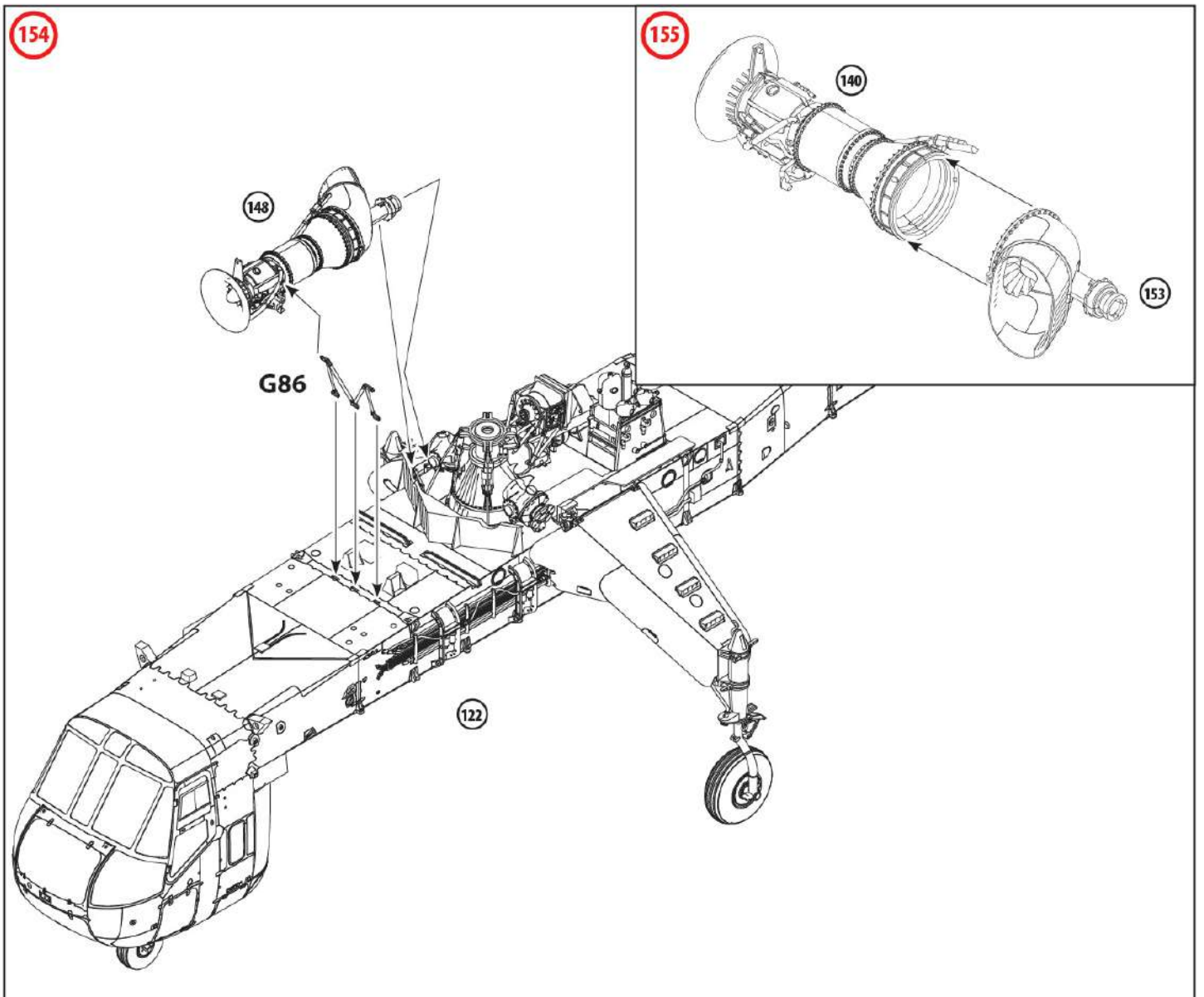
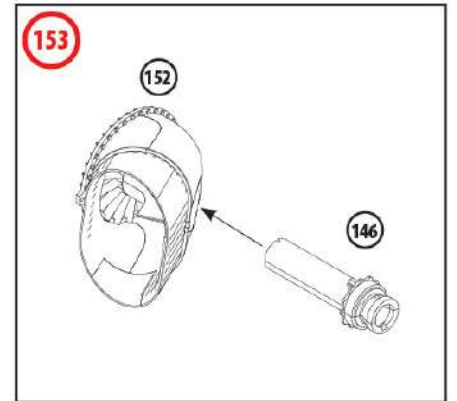
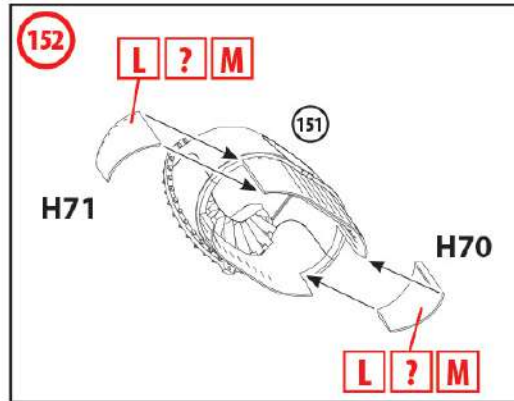
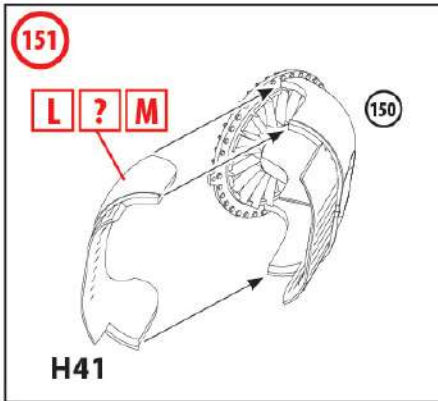
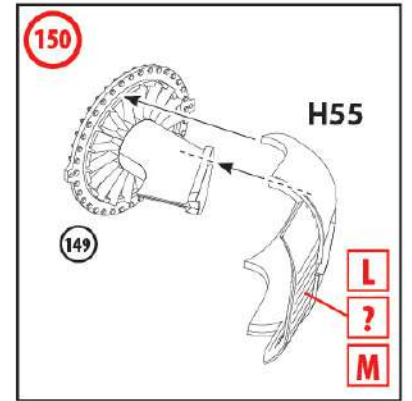
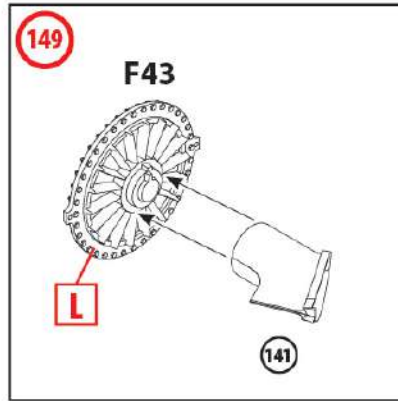
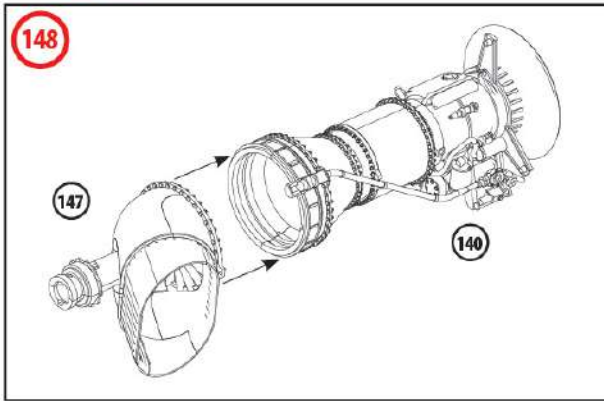

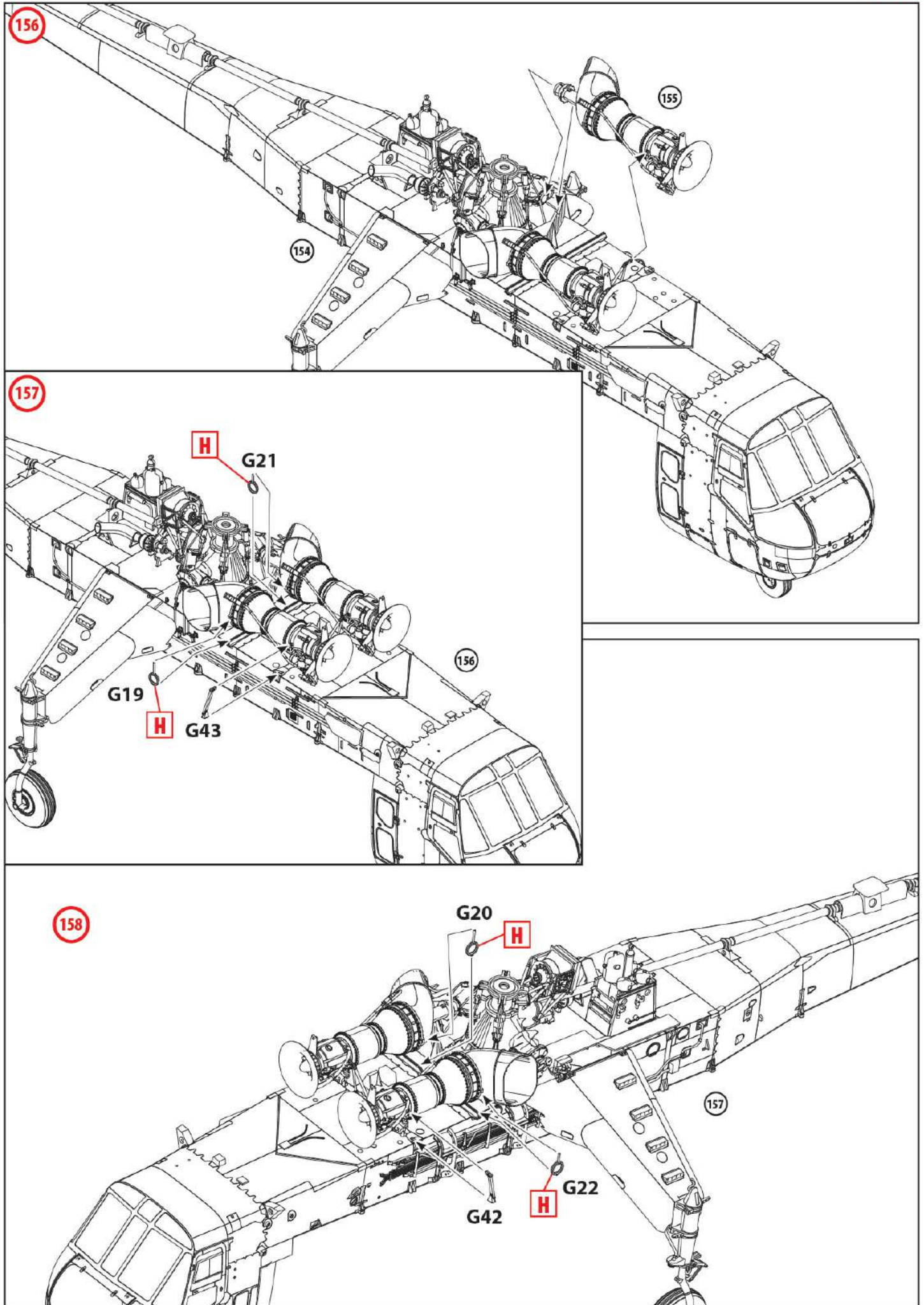

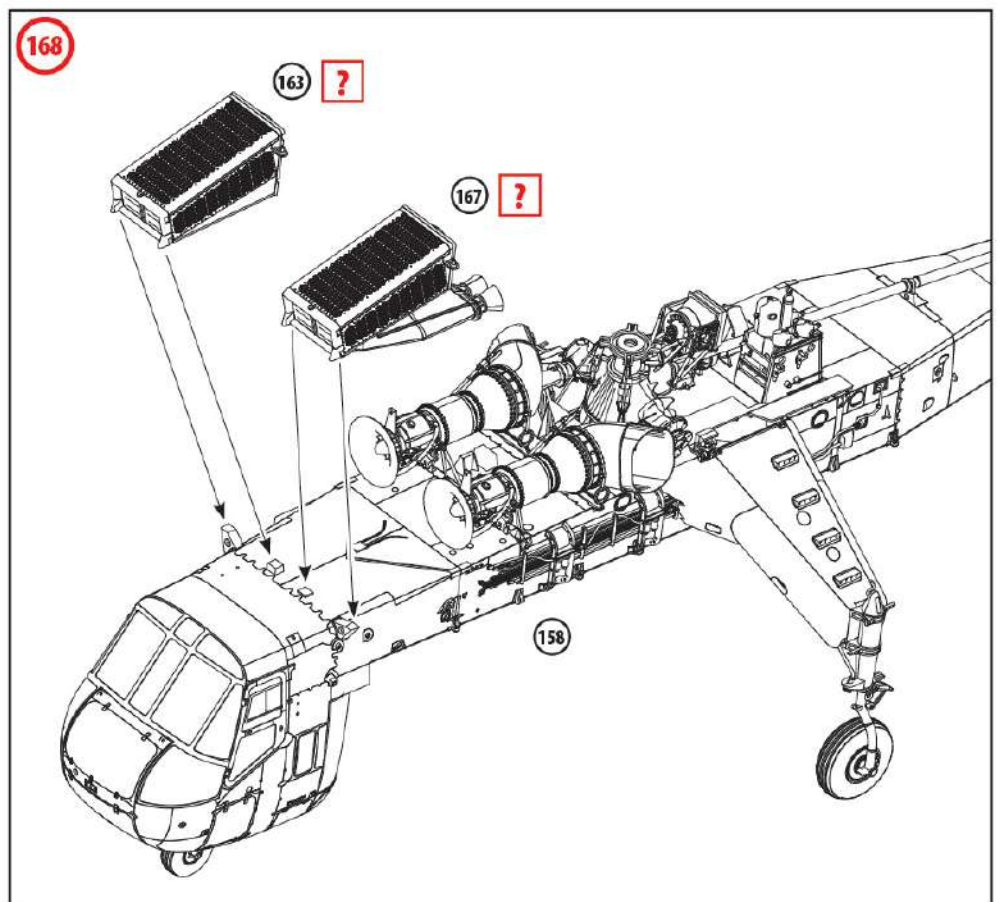
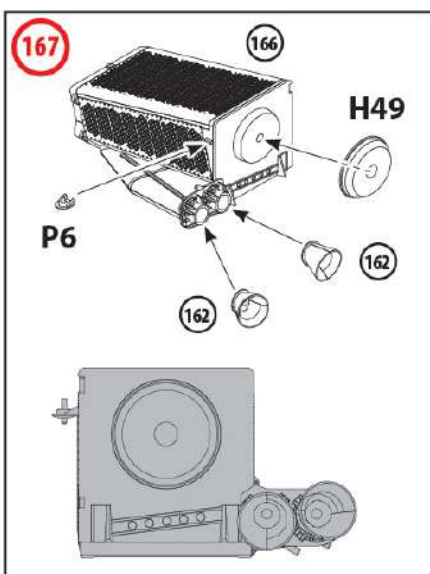
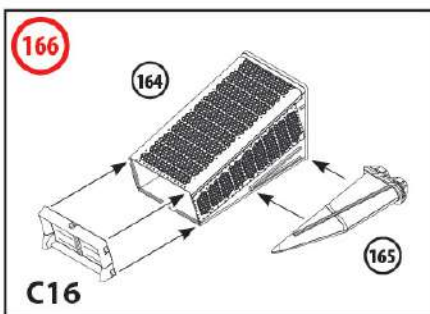
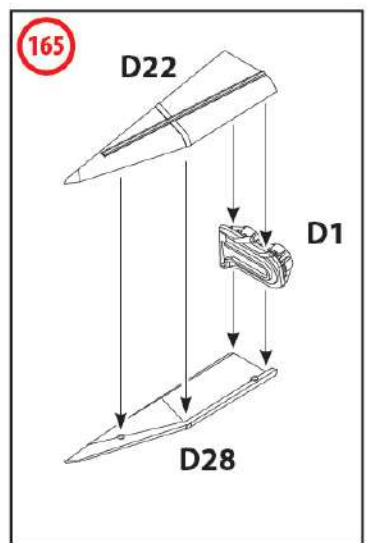
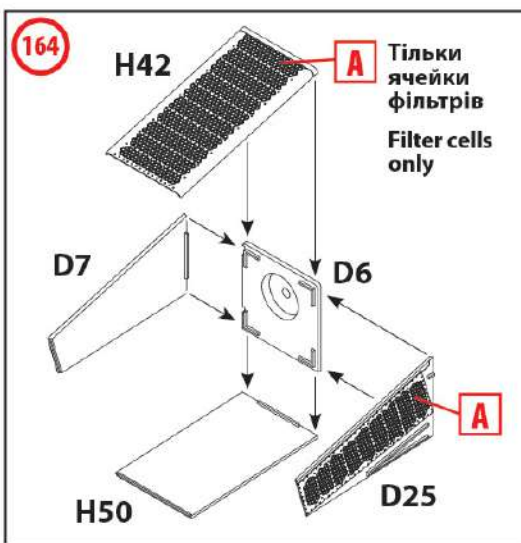
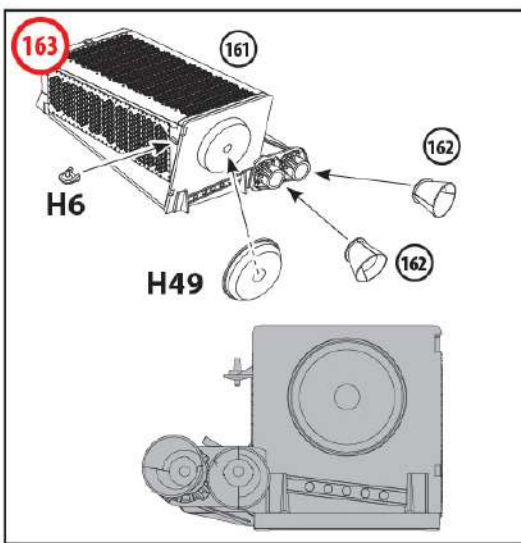
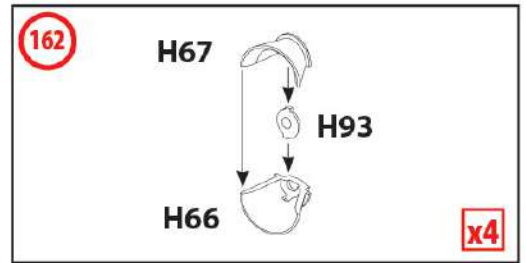
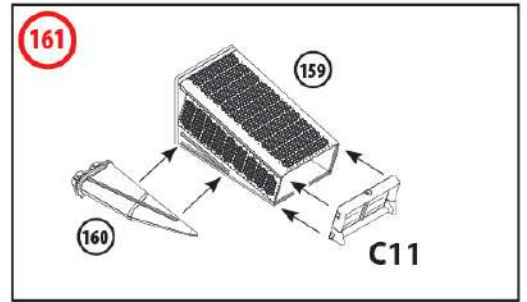
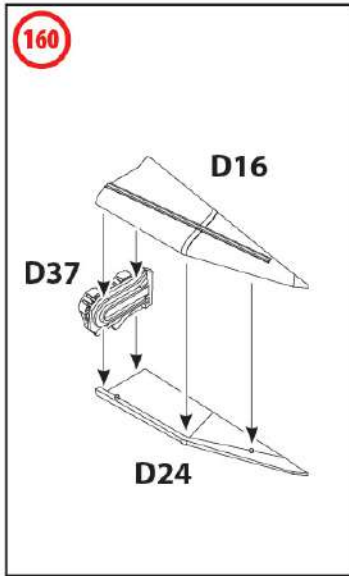
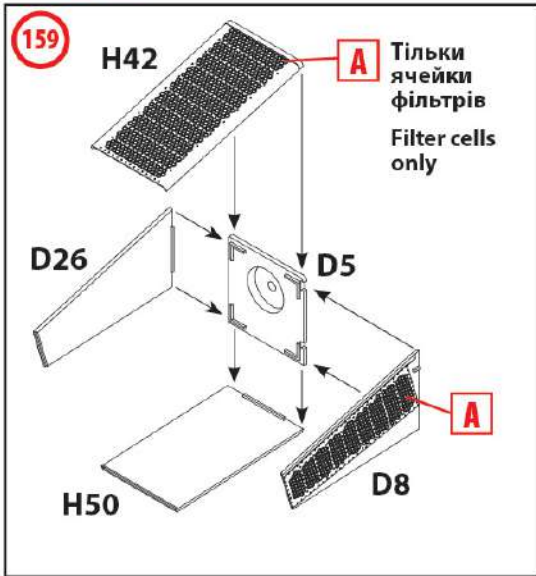

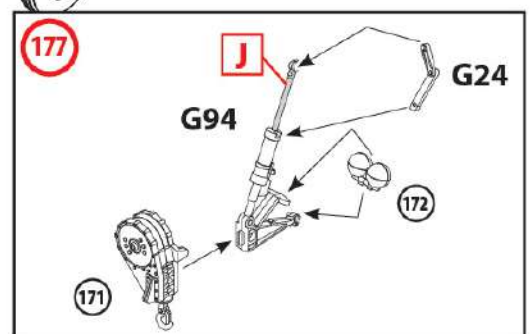
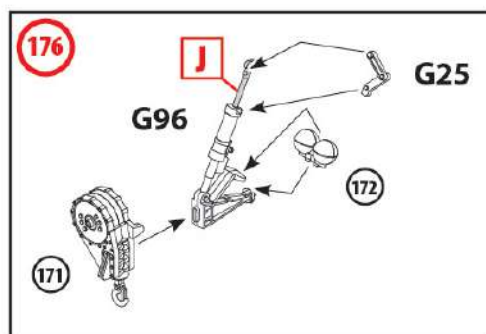
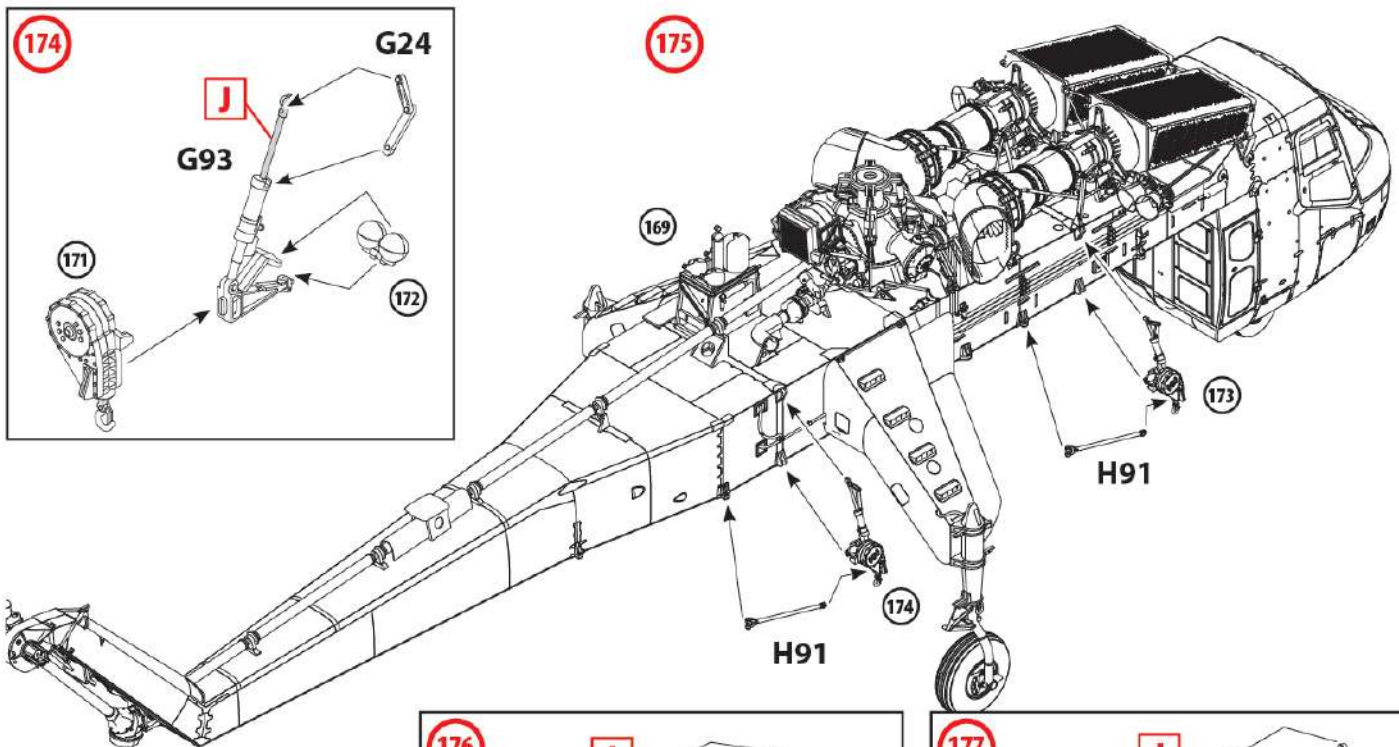
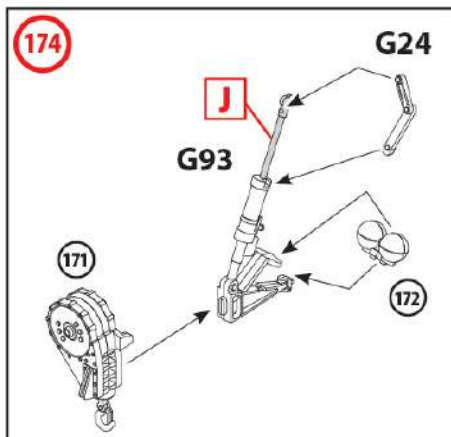
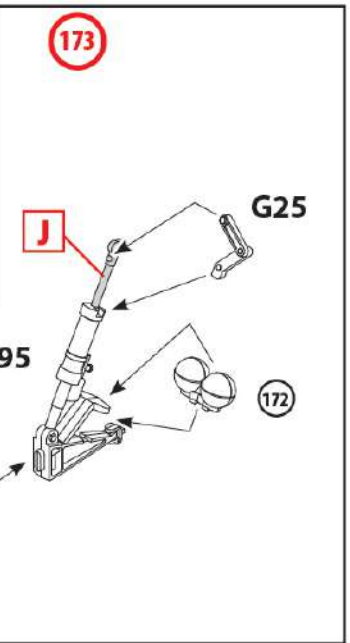
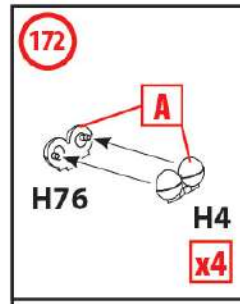
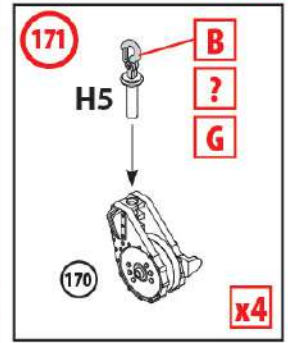
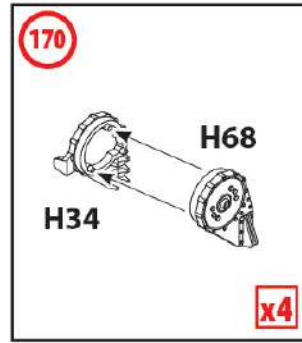
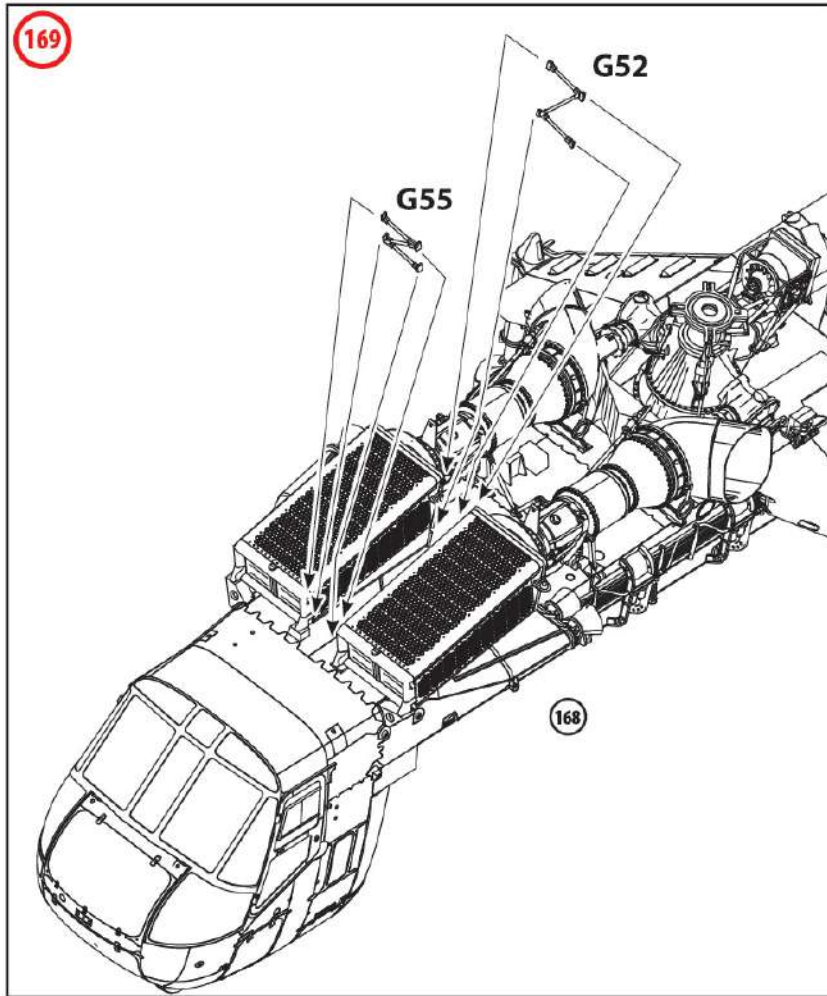

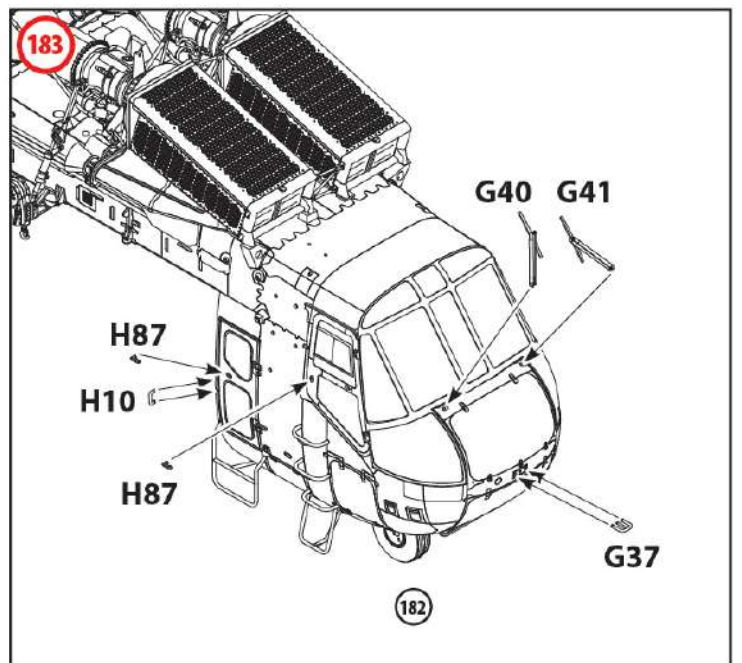
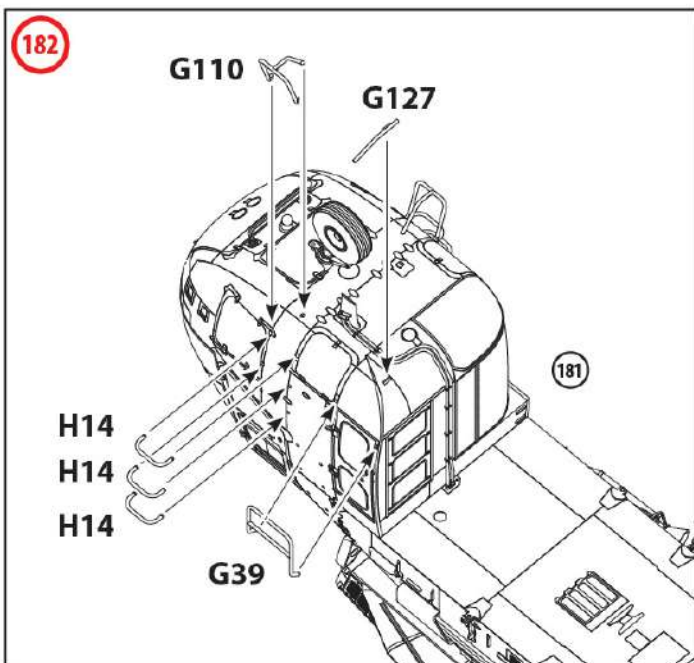
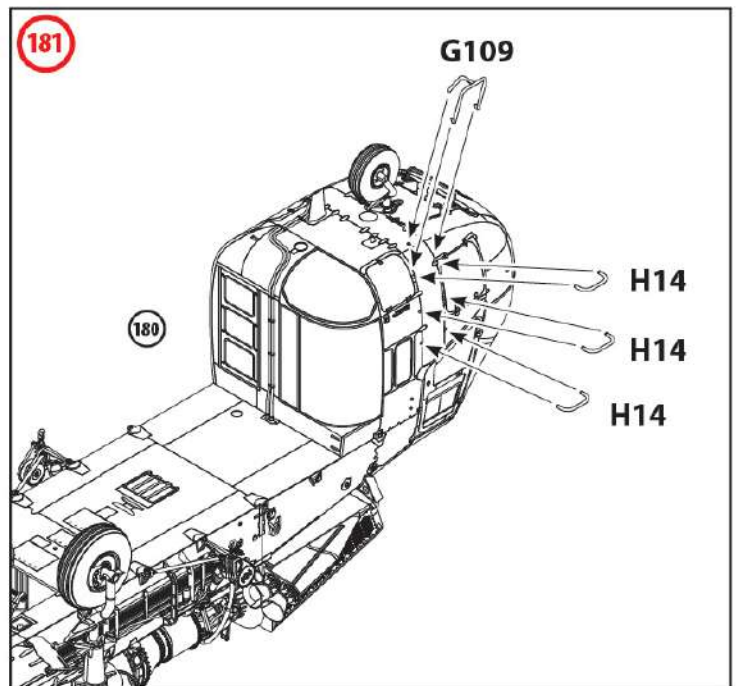
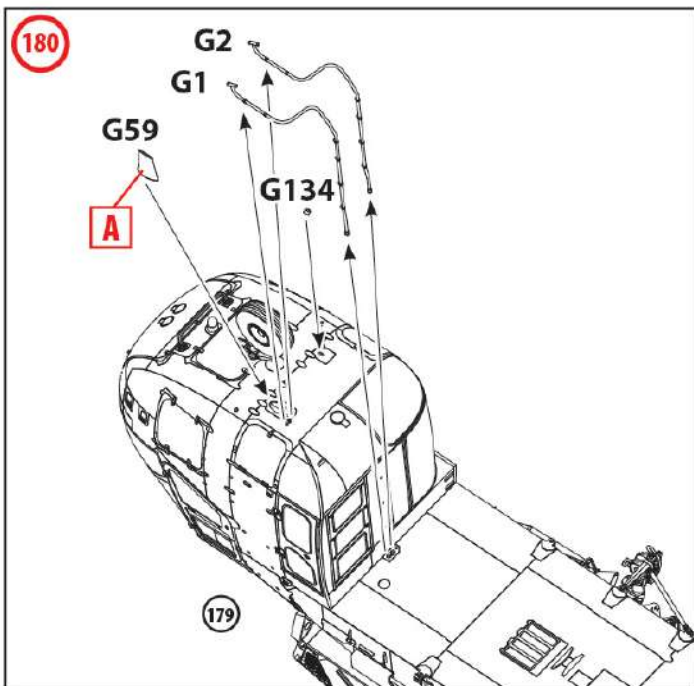
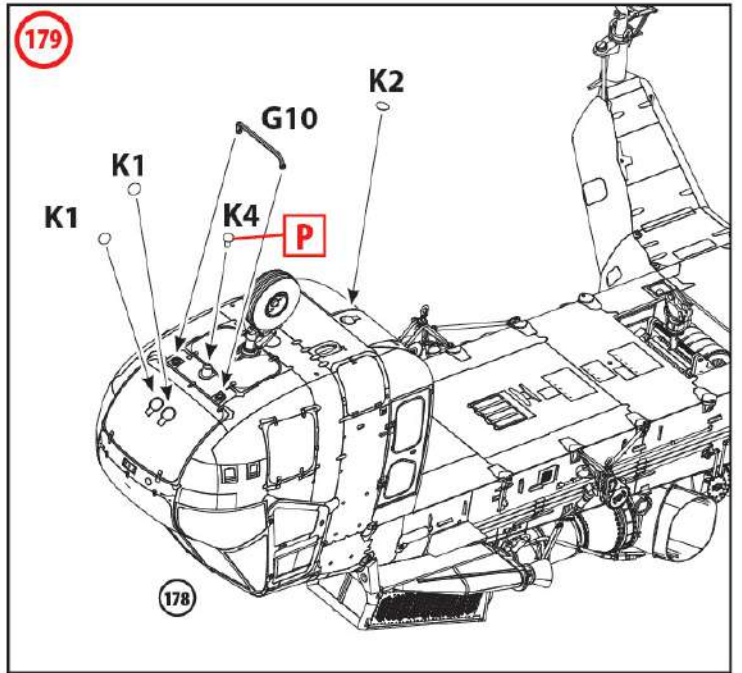
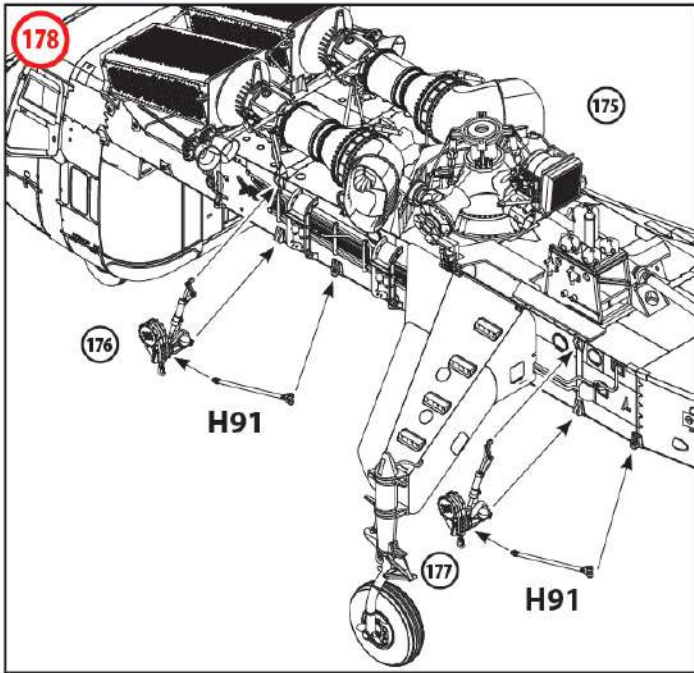

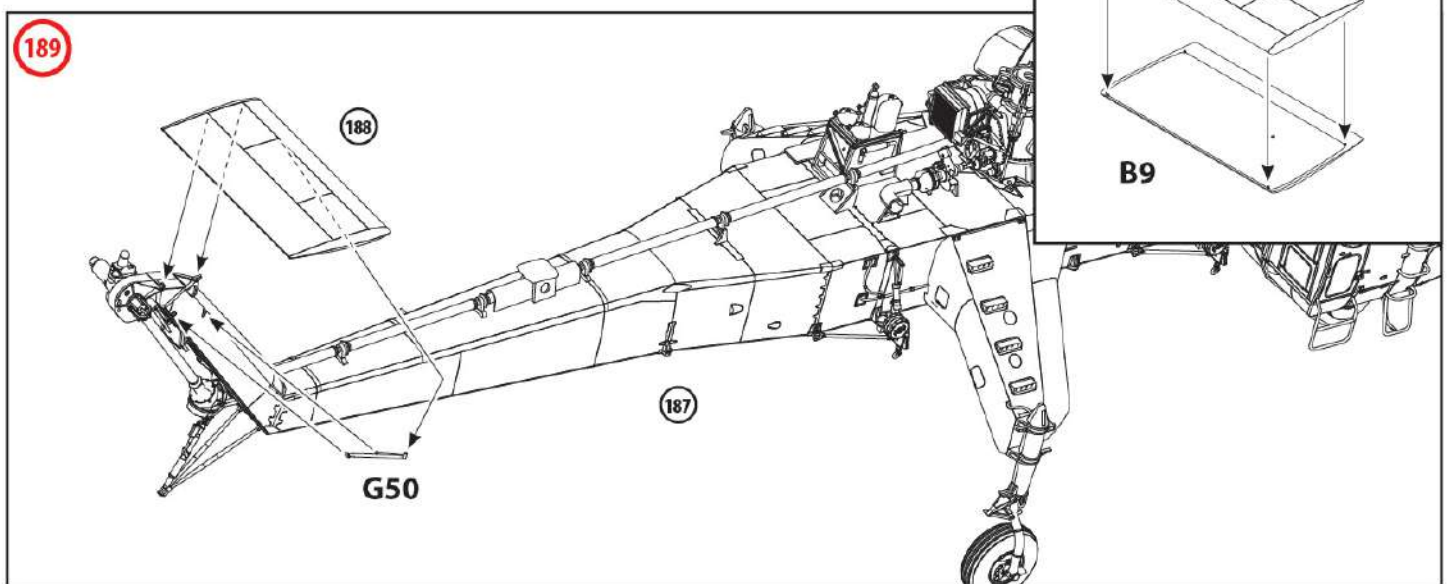
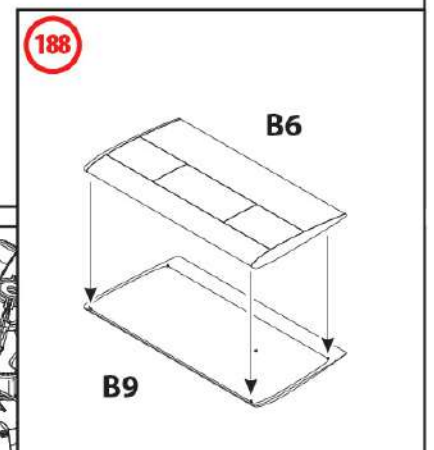
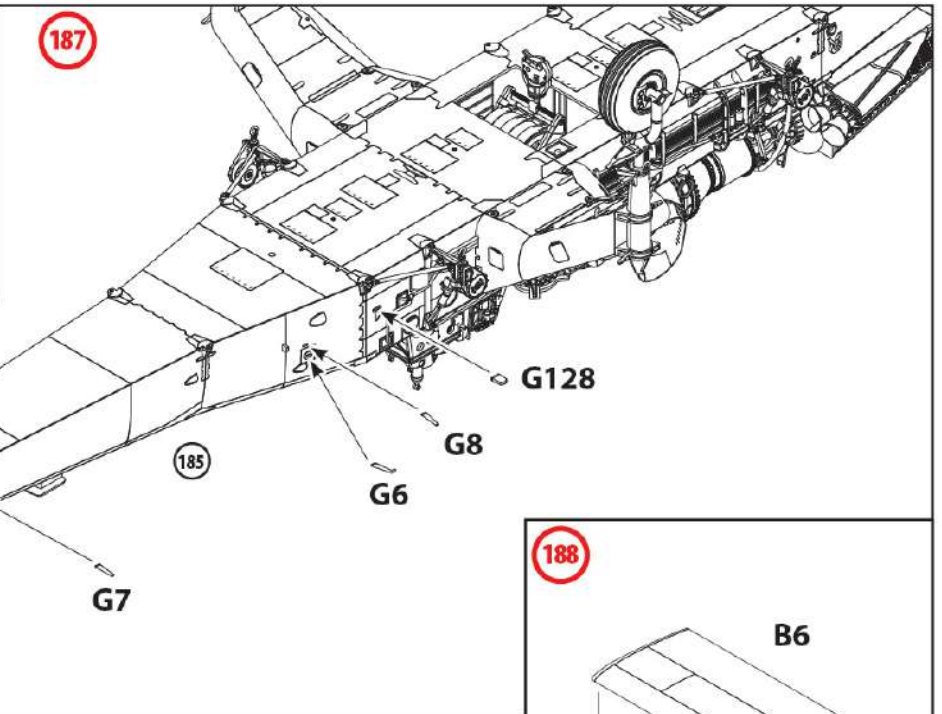
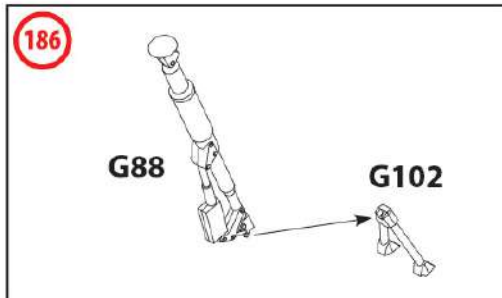
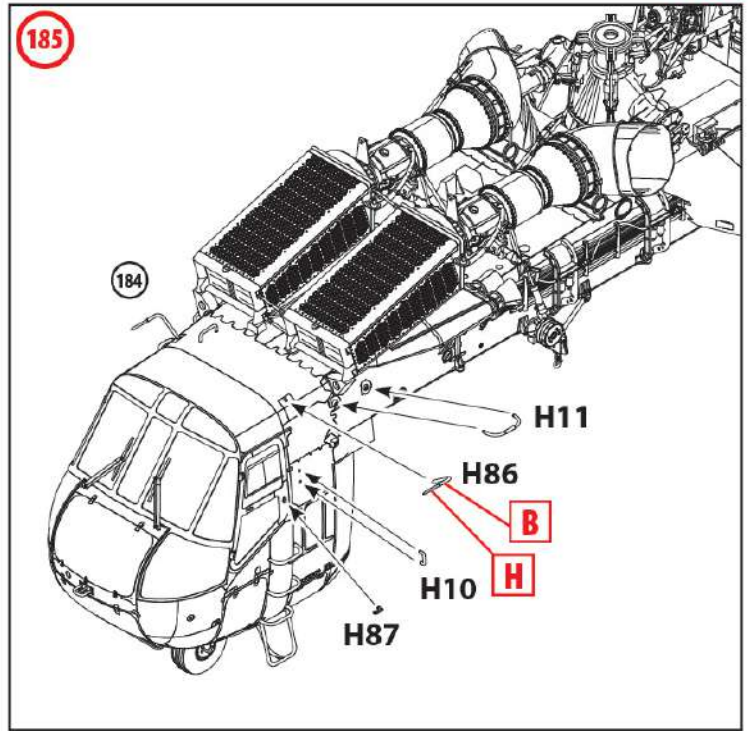
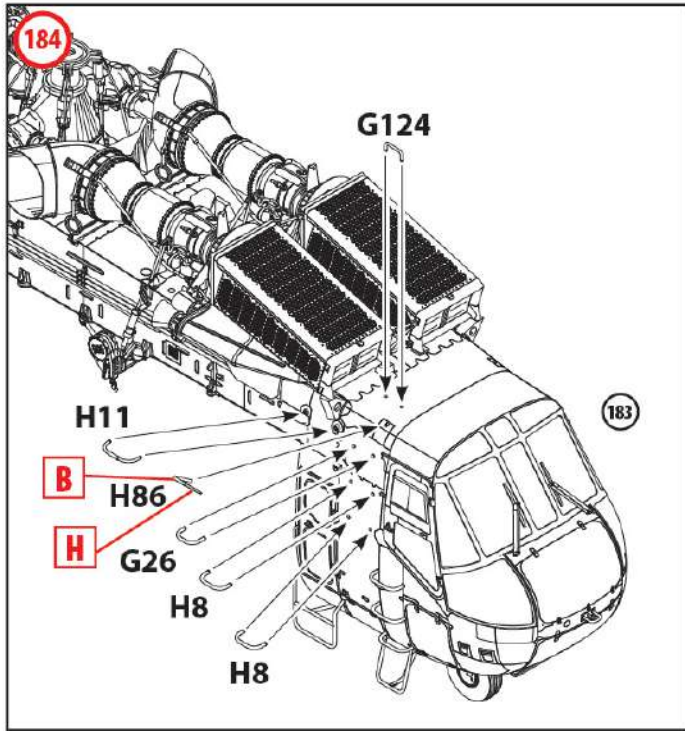

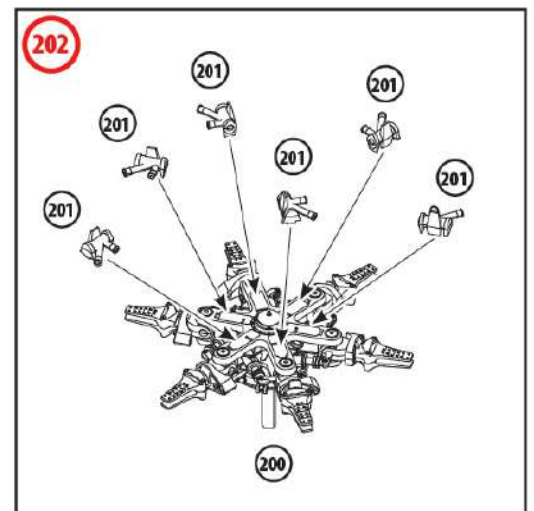
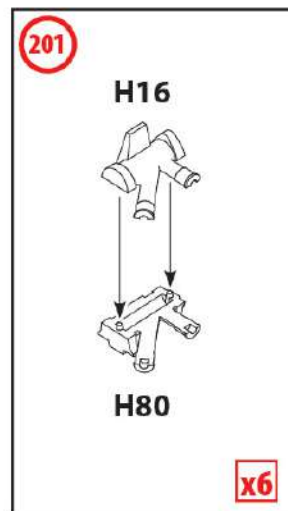
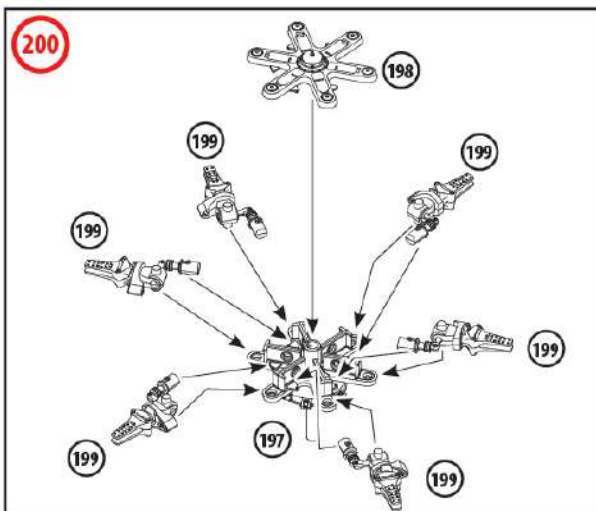
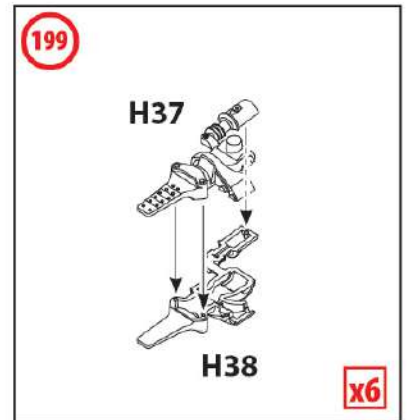
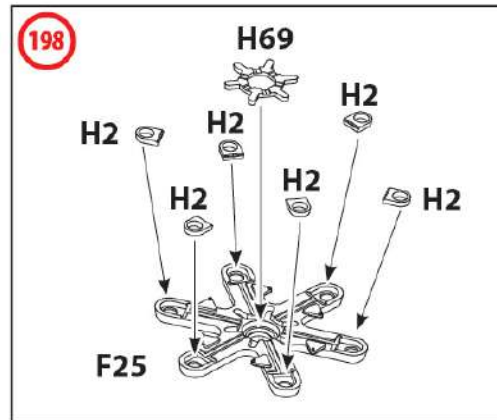
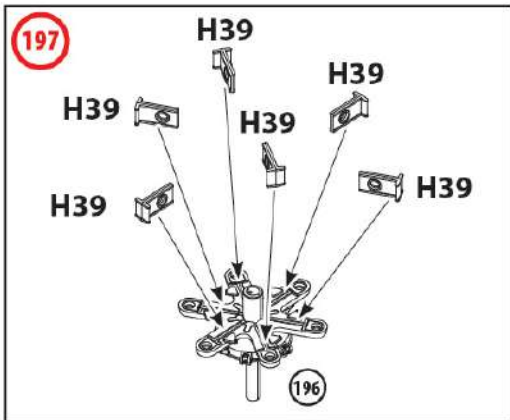
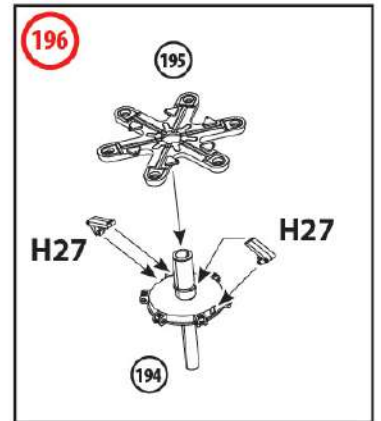
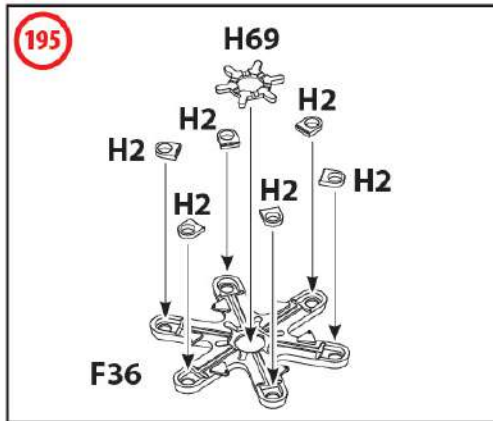
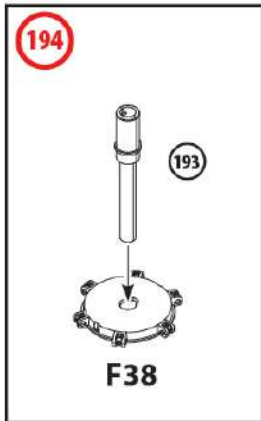
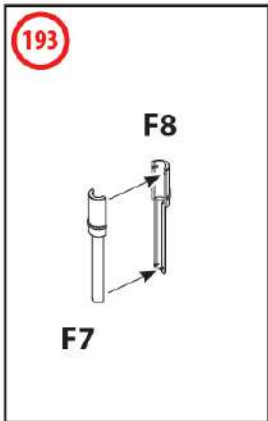
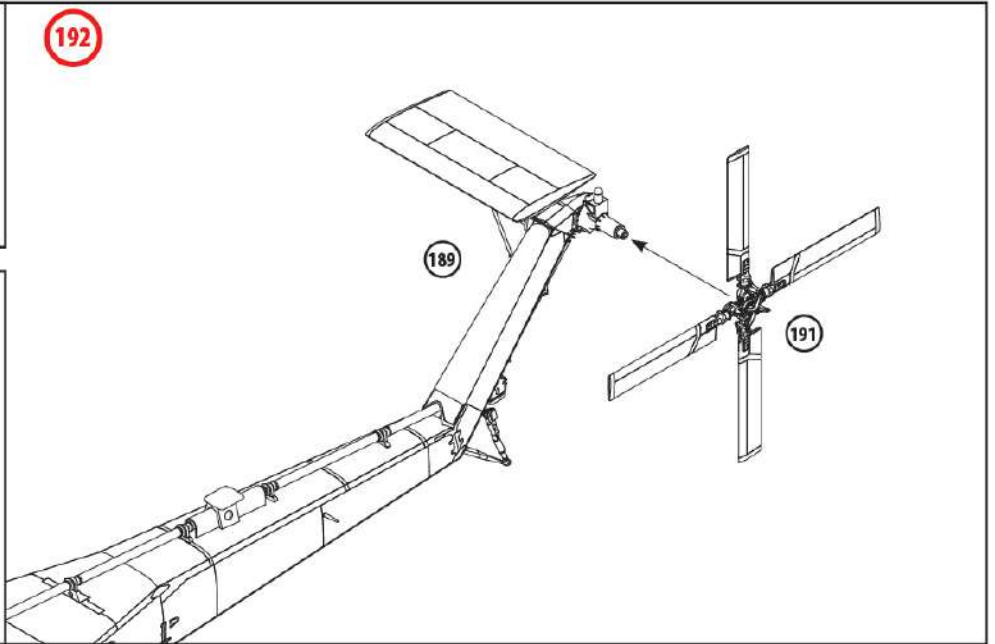
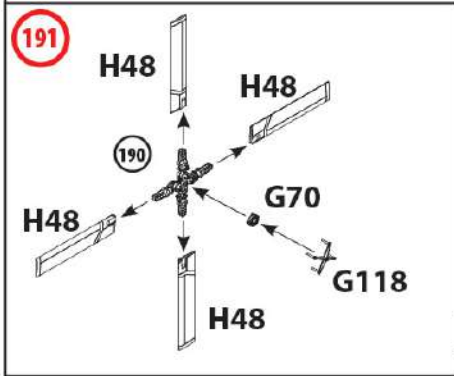
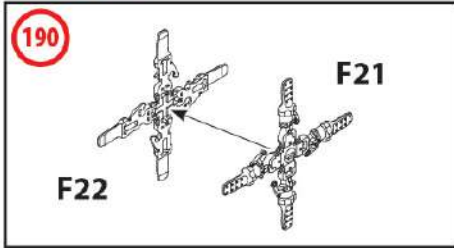

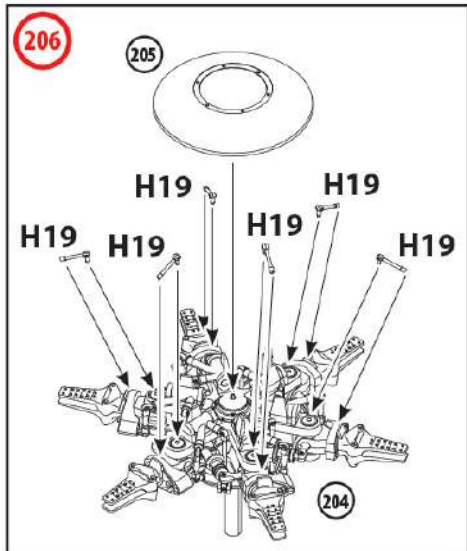
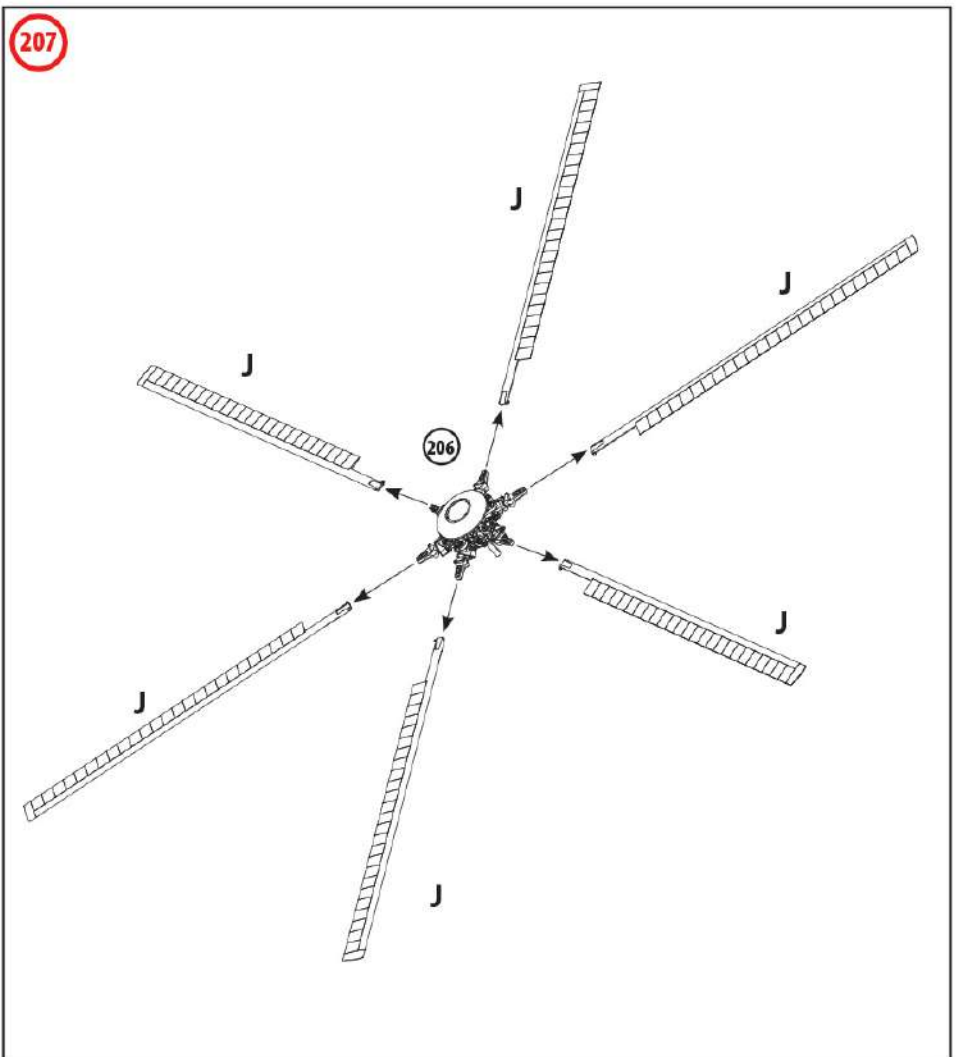
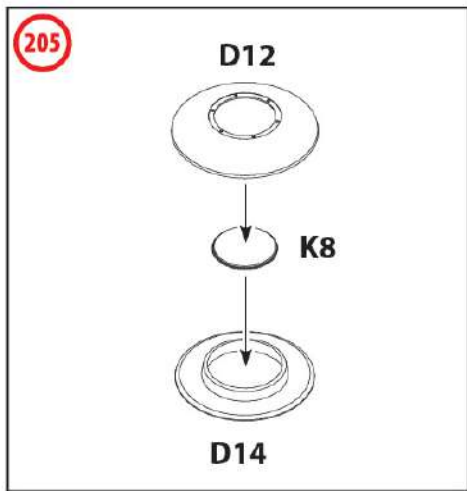
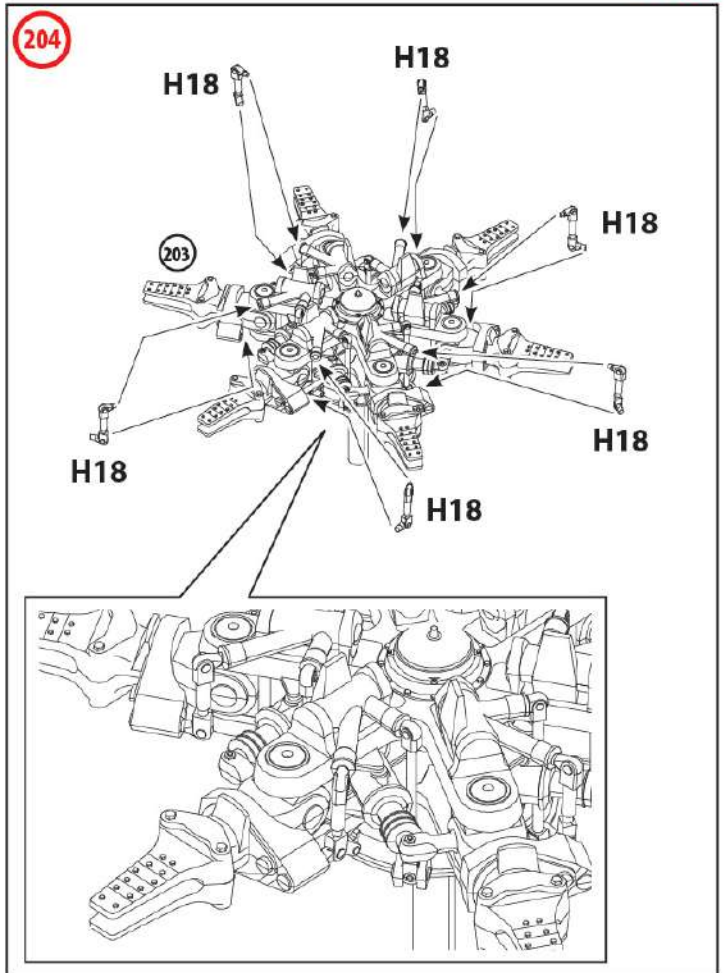
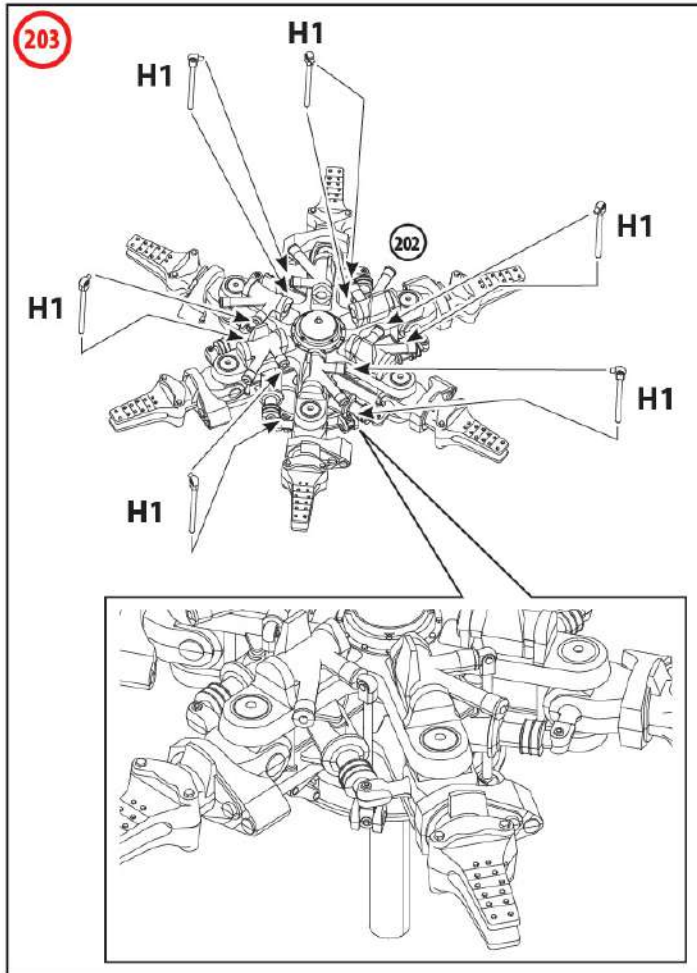

208

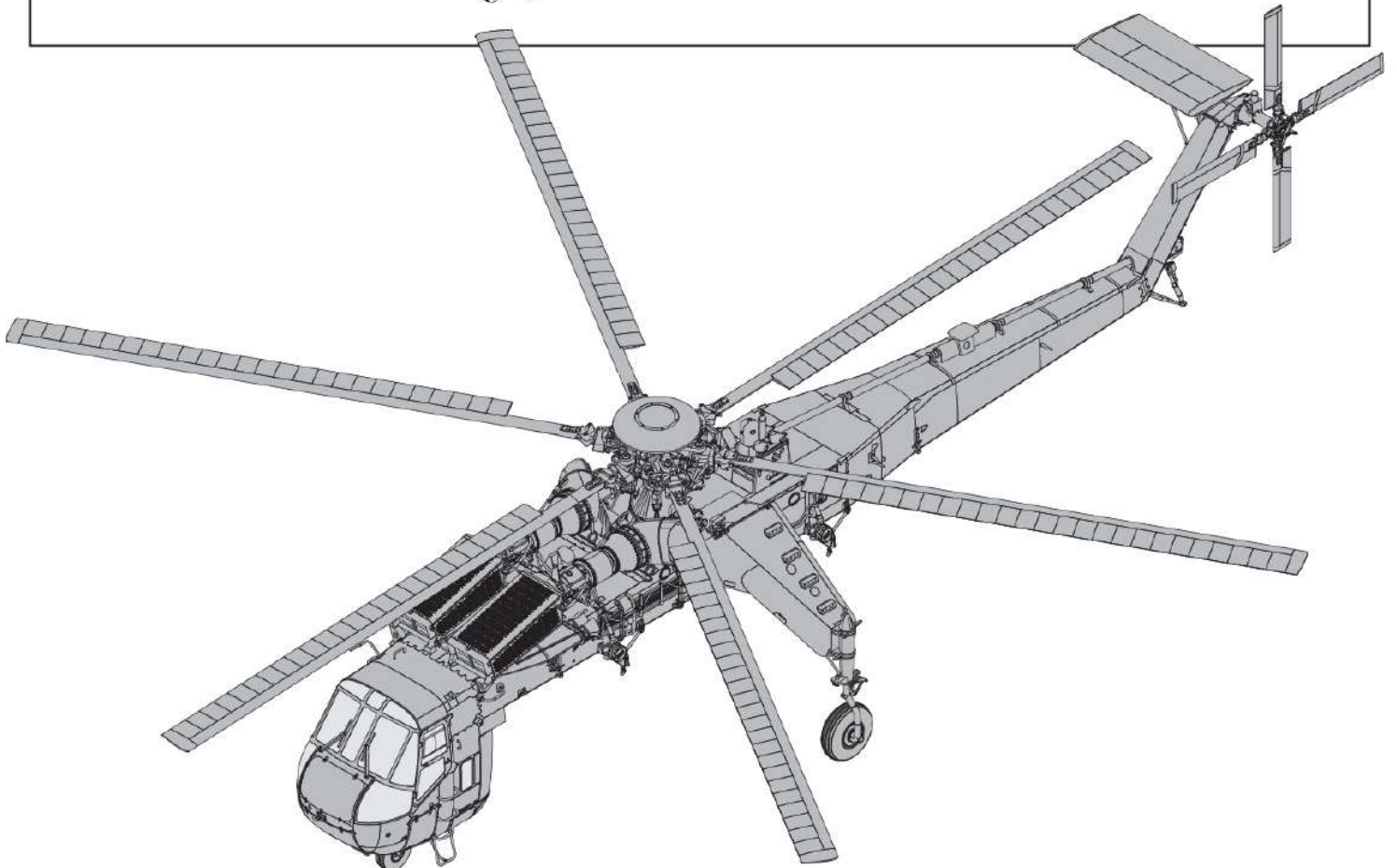
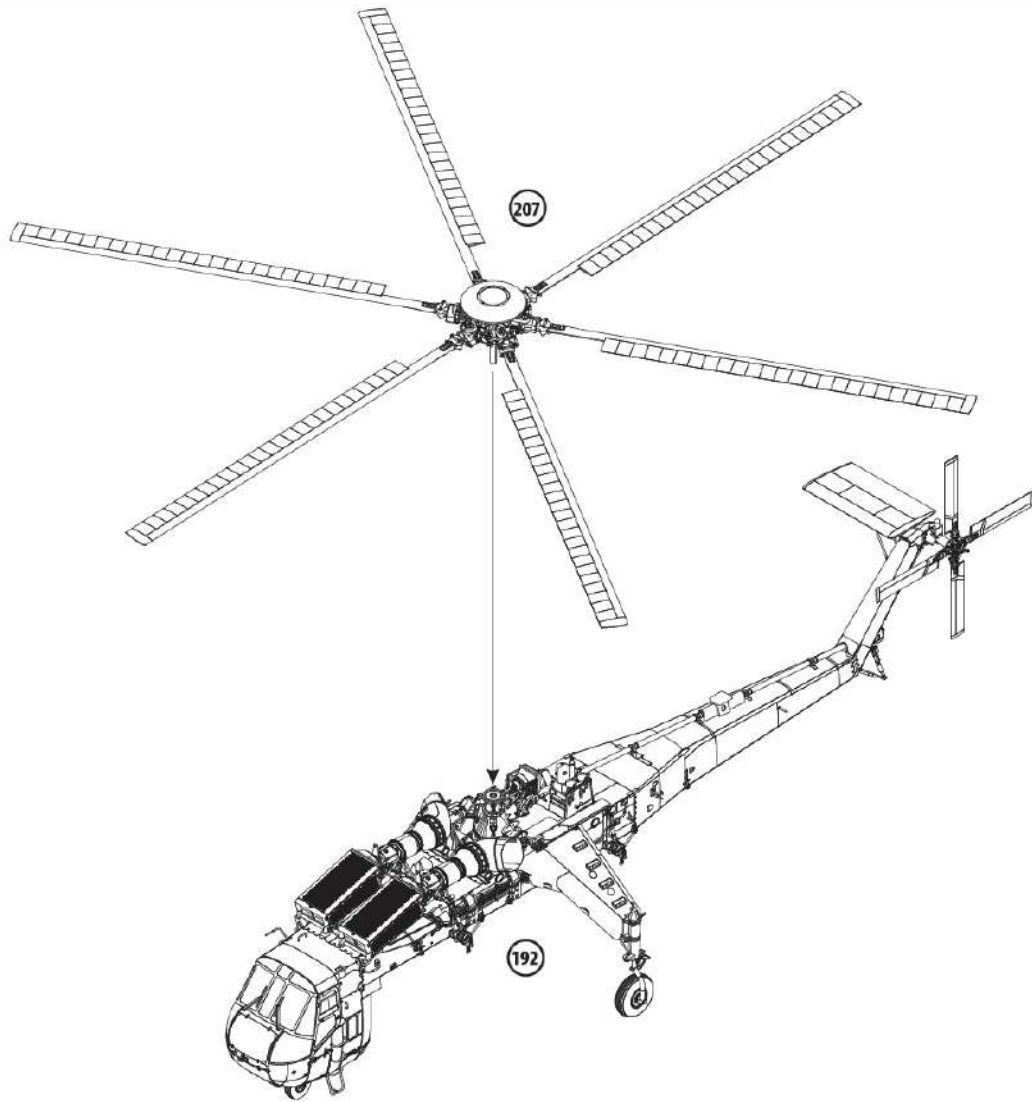

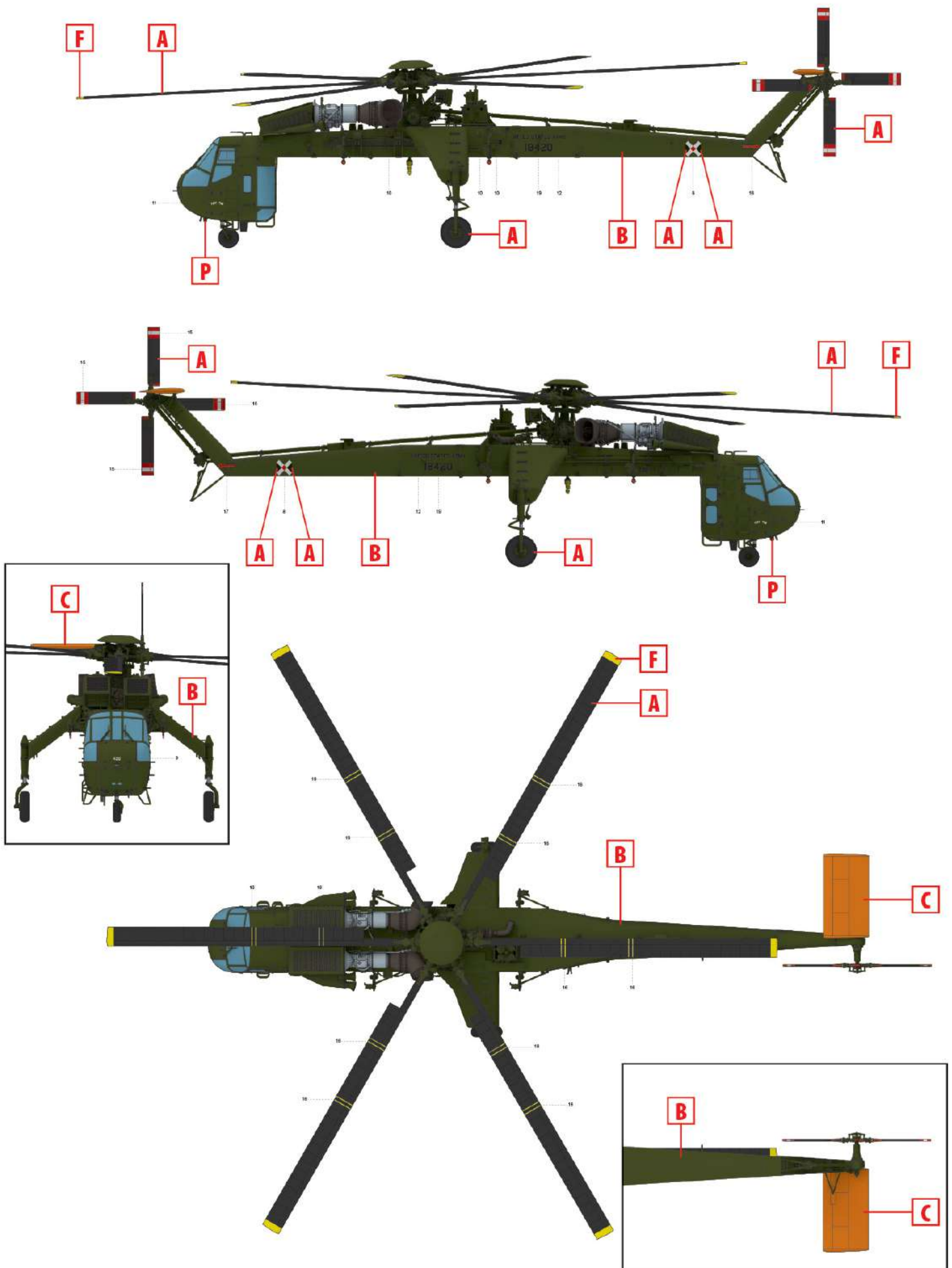

1) Sikorsky CH-54A Tarhe 67-18420, 273-я вертолітна рота штурмової підтримки, В'єтнам, 1968 рік

Sikorsky CH-54A Tarhe 67-18420, 273rd Assault Support Helicopter Company, Vietnam, 1968

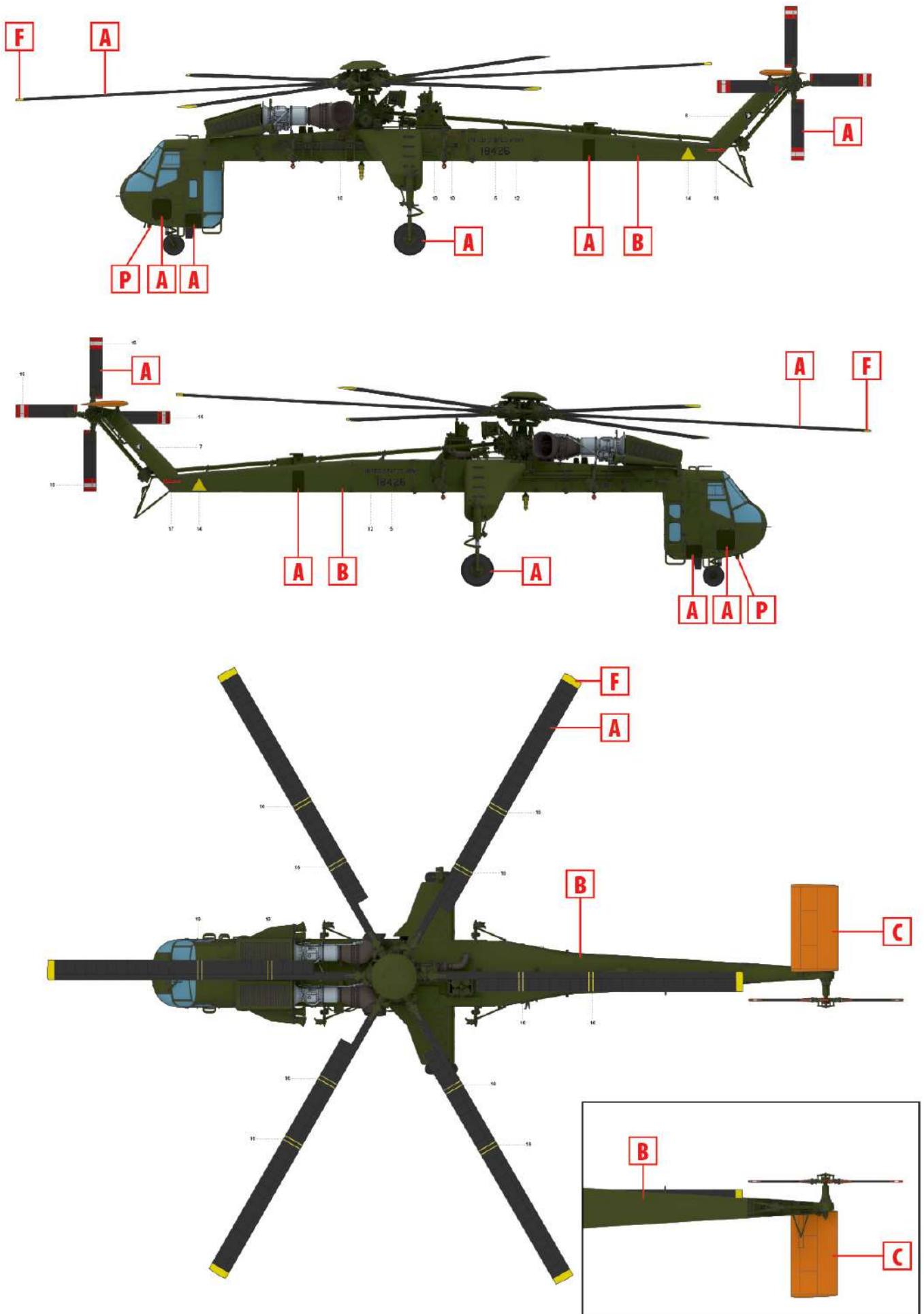

2) Sikorsky CH-54A Tarhe 67-18426, 101-ша повітряно-десантна дивізія, В'єтнам, 1969 рік

Sikorsky CH-54A Tarhe 67-18426, 101st Airborne Division, Vietnam, 1969