

Iveco Hi-Way 40th Anniversary

EN

Iveco, to celebrate the 40 years anniversary from its foundation, has created an exclusive special version of its famous heavy truck Stralis Hi-Way. The external design is characterized by a metallic blue livery with gray band that cuts the center grille. The interiors are really exclusive with a dedicated set of premium details. The Stralis Hi-Way is the latest evolution of the famous heavy duties truck produced by Iveco. The Stralis Hi-Way is characterized by several technological and aesthetic improvements compared to previous versions. The cabin offers a completely new design and is equipped with integrated electronic systems able to optimize the on-board comfort and to provide the highest safety standard. The evolution of the Stralis is also characterized by a completely new "powertrain" able to minimize the fuel consumption and the maintenance costs. In 2013 Iveco Stralis Hi-Way won the "International Truck of the Year" award assigned by a pool of journalists of the most important European trucks magazines.

IT

Iveco, per festeggiare i 40 anni di attività, ha realizzato una versione esclusiva e speciale del suo celebre trattore pesante stradale Stralis Hi-Way. Nell'aspetto esterno è caratterizzato da una livrea di colore blu metallizzato con fascia grigia che taglia al centro la calandra. Particolarmente curati anche gli interni con un allestimento dedicato. Lo Stralis Hi-Way è la più recente evoluzione del celebre trattore pesante stradale di Iveco. Lo Stralis Hi-Way si caratterizza per una serie importante di differenze tecnologiche ed estetiche se confrontate con le versioni precedenti. La cabina offre un design completamente rinnovato ed è dotata di sistemi elettronici integrati in grado di ottimizzare il comfort di bordo e la sicurezza. L'evoluzione dello Stralis si caratterizza inoltre per un "powertrain" in grado di minimizzare il consumo del carburante e di ridurre al minimo i costi di manutenzione. Nel 2013 Iveco Stralis Hi-way ha vinto il premio "International Truck of the Year" assegnato dai giornalisti delle più importanti riviste specializzate europee.

DE

Iveco hat anlässlich seines 40 jährigen Bestehens eine exklusive und spezielle Version seiner berühmten Straßenzugmaschine Stralis Hi-Way verwirklicht. Außen ist er durch eine Blaumetallic-Bemalung und einem grauen Band gekennzeichnet, das über die Mitte der Kühlerhaube verläuft. Besonders gepflegt ist auch das Innere mit einer speziellen Ausstattung. Der Stralis Hi-Way ist die neueste Entwicklung der berühmten Straßenzugmaschine und sie zeichnet sich im Vergleich zu den vorherigen Modellen durch eine Reihe wichtiger, technologischer und ästhetischer Unterschiede aus. Die Fahrkabine bietet ein vollkommen neues Design und ist mit integrierten elektronischen Anlagen, ausgestattet, die in der Lage sind, den Fahrkomfort und die Sicherheit zu optimieren. Die fortschrittliche Entwicklung des Stralis zeichnet sich außerdem durch einen "Powertrain" aus, der den Treibstoffverbrauch drastisch reduziert und die Wartungskosten auf ein Minimum beschränkt. Im Jahre 2013 gewann der Stralis Hi-Way von Iveco der Preis "International Truck of the Year", der von Journalisten der wichtigsten europäischen Fachzeitschriften verliehen wird.

FR

Pour fêter ses 40 ans d'activité, Iveco a réalisé une version exclusive et spéciale de son célèbre tracteur lourd routier Stralis Hi-Way. Son aspect extérieur est caractérisé par sa couleur bleu métallisé avec une bande grise qui tranche le centre de la calandre. Les détails internes sont particulièrement soignés avec un équipement dédié. Le Stralis Hi-Way est l'évolution la plus récente du célèbre tracteur lourd routier Iveco et il est caractérisé par une série importante d'innovations technologiques et esthétiques qui le différencient des versions précédentes. Le design de la cabine a été complètement revu ; elle est équipée de systèmes électroniques intégrés en vue de optimiser le confort à bord et la sécurité. L'évolution du Stralis se caractérise également dans l'adoption d'un "powertrain" qui permet de réduire la consommation de carburant et de minimiser les frais d'entretien. En 2013, Iveco Stralis Hi-way a reçu le prix "International Truck of the Year", décerné par les journalistes des revues spécialisées les plus importantes d'Europe.

ES

Iveco, para festejar los 40 años de trabajo, ha realizado una versión exclusiva y especial de la famosa tractora Stralis Hi-Way para grandes cargas. El aspecto externo está caracterizado por una livrea de color azul metalizado con una franja gris que corta al centro al calandra. También el interior es particularmente minucioso con un acabado específico. El Stralis Hi-Way es la evolución más reciente de la famosa tractora para grandes cargas de Iveco, y se caracteriza por una serie importante de diferencias tecnológicas y estéticas si se comparan con las versiones anteriores. La cabina tiene un diseño completamente renovado y dispone de sistemas electrónicos integrados capaces de optimizar el confort y la seguridad. La evolución del Stralis se caracteriza también por un "powertrain" capaz de minimizar el gasto de carburante y de reducir al mínimo los gastos de mantenimiento. En el 2013, Iveco Stralis Hi-way consiguió el premio "International Truck of the Year" asignado por los periodistas de las revistas especializadas europeas más importantes.

RU

Компания Iveco, чтобы отметить 40 лет деятельности, выпустила эксклюзивную и специальную версию своего знаменитого тяжелого магистрального тягача Stralis Hi-Way. Внешний вид характеризуется темно-синей металлизированной livреей с серой полосой, проходящей по центру решётки радиатора. Особое внимание уделено внутренним деталям, с особым оснащением. Stralis Hi-Way это самый современный вариант знаменитого тяжелого магистрального тягача компании Iveco характеризуется рядом важных технологических и эстетических характеристик, отличающих его от предыдущих версий. Кабина отличается совершенно новым дизайном и оснащена встроенными электронными системами, оптимизирующими комфорт на борту и безопасность. Эволюция Stralis отличается силовым агрегатом, позволяющим свести к минимуму потребление топлива и максимально сократить стоимость техобслуживания. В 2013 году тягач Iveco Stralis Hi-way получил премию "International Truck of the Year", присуждаемую журналистами наиболее важных специализированных журналов Европы.



- EN WARNING:** Model for adult collector age 14 and over
IT ATTENZIONE: Modello per collezionisti adulti di età superiore ai 14 anni
FR ATTENTION: Modèle pour modélistes de 14 ans et plus.
DE ACHTUNG: Modellbausatz Für Modellbauer über 14 Jahre.
NL WAARSCHWING: Geschikt voor 14 jaar en ouder.
ES ATENCION: Modelo para modelistas mayores de 14 años.

EN ATTENTION - Useful advice!

Study the instructions carefully prior to assembly. Remove parts from frame with a sharp knife or a pair of scissor and trim away excess plastic. Do not pull off parts. Assemble the parts in numerical sequence. Use plastic cement ONLY and use cement sparingly to avoid damaging the model. Black arrows indicate parts to be glued together. White arrows indicate on which frame the parts must be assembled WITHOUT using cement. These letters (A - B - C...) indicate on which frame the parts will be found. Paint small parts before detaching them from frame. Remove paint-where parts are to be cemented. Crossed out parts must not be used.

IT ATTENZIONE - Consigli utili!!

Prima di iniziare il montaggio studiare attentamente il disegno. Staccare con molta cura i pezzi dalle stampe, usando un taglia-balsa oppure un paio di forbici e togliere con una piccola lima o con carta vetro fine eventuali sbavature. Mai staccare i pezzi con le mani. Montarli seguendo l'ordine delle numerazioni delle tavole. Eliminare dalla stampata il numero del pezzo appena montato facendogli sopra una croce. Le frecce nere indicano i pezzi da incollare, le frecce bianche indicano i pezzi da montare senza colla. Usare solo colla per polistirolo. Le lettere (A - B - C...) ai lati dei numeri indicano la stampata ove si trova il pezzo da montare. I pezzi sbarrati da una croce non sono da utilizzare.

DE ACHTUNG - Ein nützlicher Rat!

Vor der Montage die Zeichnung aufmerksam studieren. Die einzelnen Montageteile mit einem Messer oder einer Schere vom Spritzling sorgfältig entfernen. Eventuelle Grate werden mit einer Klinge oder feinem Schmirgelpapier beseitigt. Keinesfalls die Montageteile mit den Händen entfernen. Bei der Montage der Tafelnummerierung folgen. Pfeile zeigen die zu klebenden Teile während die weissen Pfeile die ohne Leim zu montierenden Teile anzeigen. Bitte nur Plastikklebstoff verwenden. Die Buchstaben (A - B - C...) neben den Nummern zeigt, auf welchem Spritzling der zu montierende Teil zu finden ist. Die mit einem Kreuz markierten Teile sind nicht zu verwenden.

FR ATTENTION - Conseils utiles!

Avant de commencer le montage, étudier attentivement le dessin. Détacher avec beaucoup de soin les morceaux des moules en usant un massicot ou bien un pair de ciseaux et couper avec une petite lame avec de papier de verre fin ébarbés éventuels. Jamais détacher les morceaux avec les mains. Monter les en suivant l'ordre de la numération des tables. Éliminer de la moule le numéro de la pièce qui vient d'être montée, en la bifant avec une croix. Les flèches noires indiquent les pièces à coller, les flèches blanches indiquent les pièces à monter sans colle. Employer seulement de la colle pour polystyrol. Les lettres (A - B - C...) aux côtés des numéros indiquent la moule où se trouve la pièces à monter. Les pièces marquées par une croix ne sont pas à utiliser.

NL OPGELET - Belangrijke bemerkingen!

Bestudeer zorgvuldig het montageplan voor het bouwen. Breek nooit onderdelen van het kader. Maak ze los met een scherp mes of kleine angeltang. Verwijder daarna al het overtollige plastic en pas de delen afvoeren te lijmen. Gebruik alleen lijm voor plastic modellen. Werk zorgvuldig en spaarzaam, teveel lijm zal uw model beschadigen. Zwarte pijlen duiden de te lijmen delen aan. Witte pijlen verwijzen naar bewegende delen welke niet mogen worden gelijmd. Deze letters (A - B - C...) geven de kaders aan waarin de onderdelen zich bevinden. Schilder de kleine onderdelen voor ze van het kader te snijden. Verwijder de verf van de te lijmen oppervlakten.

ES ATENCION - Consejos útiles!

Estudiar las instrucciones cuidadosamente antes de comenzar el montaje. Separar las piezas de las bandejas con un cuchillo afilado o un par de tijeras y retirar el exceso de plástico o rebada. No arrancar las piezas. Montar las piezas en orden numérico. Utilizar SOLAMENTE pegamento para plástico y en poca cantidad para evitar que se dane el modelo. Las flechas negras indican las piezas que se deben pegar juntas. Las flechas blancas indican las piezas que deben ensamblarse SIN usar pegamento. Las letras (A - B - C...) indican en que bandeja se encuentran las piezas. Pintar las piezas pequeñas antes de separarlas de la bandeja. Retirar la pintura de los lugares por donde se deban pegar las piezas.

A

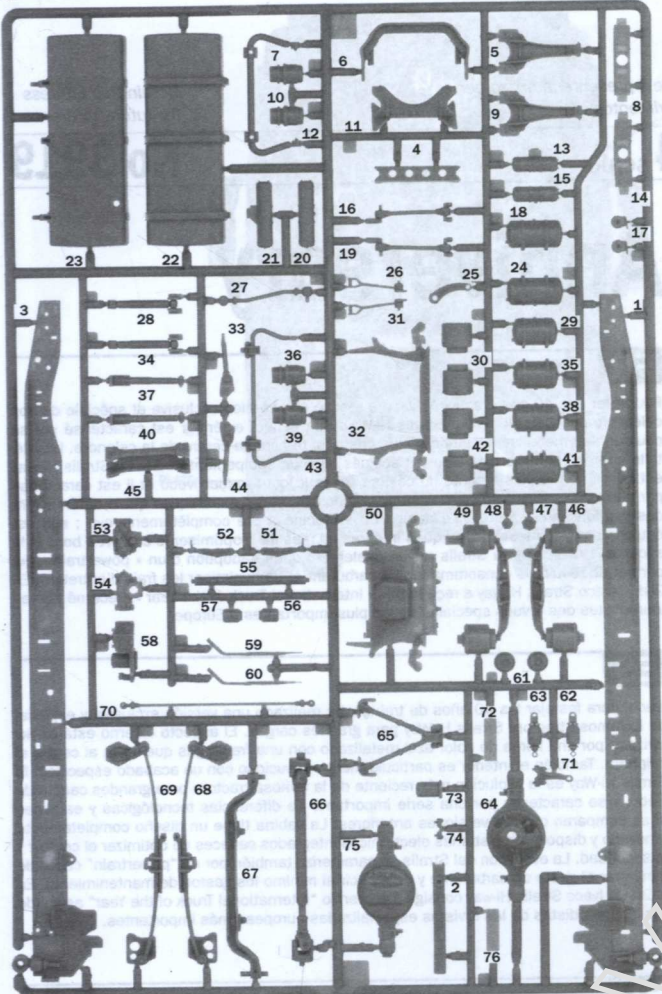

B

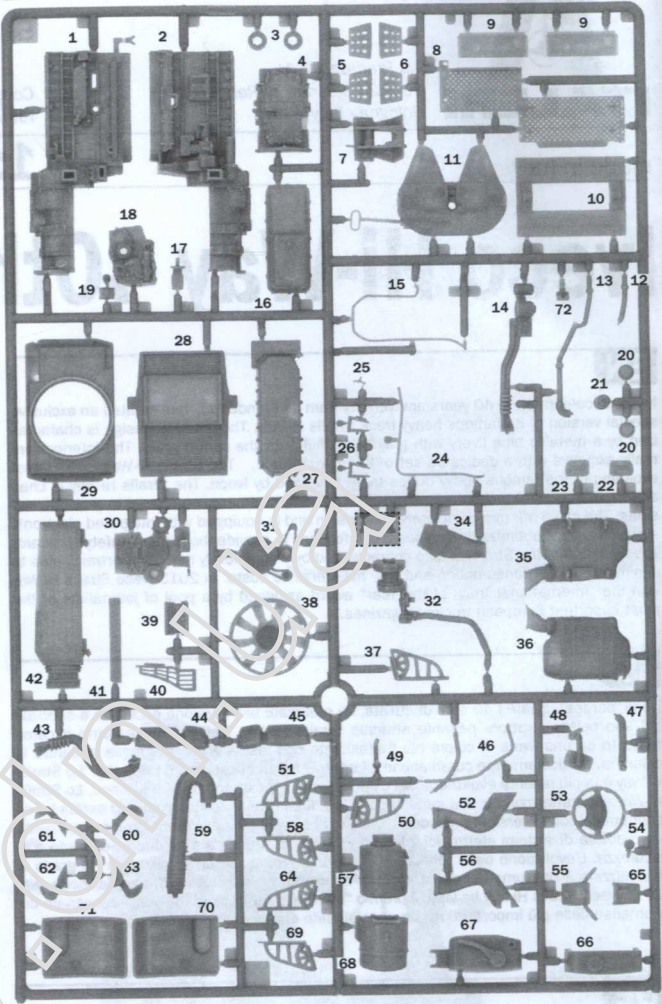

C

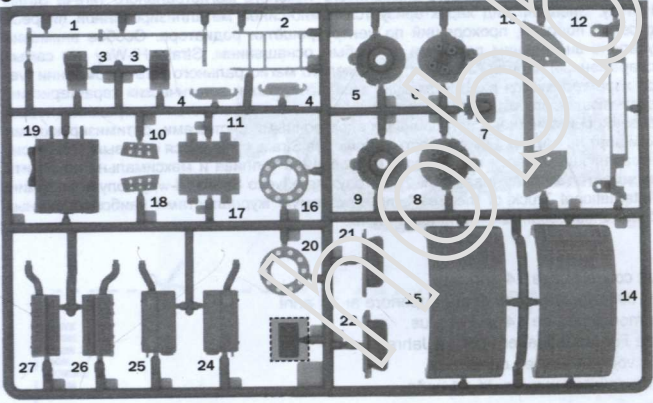

I

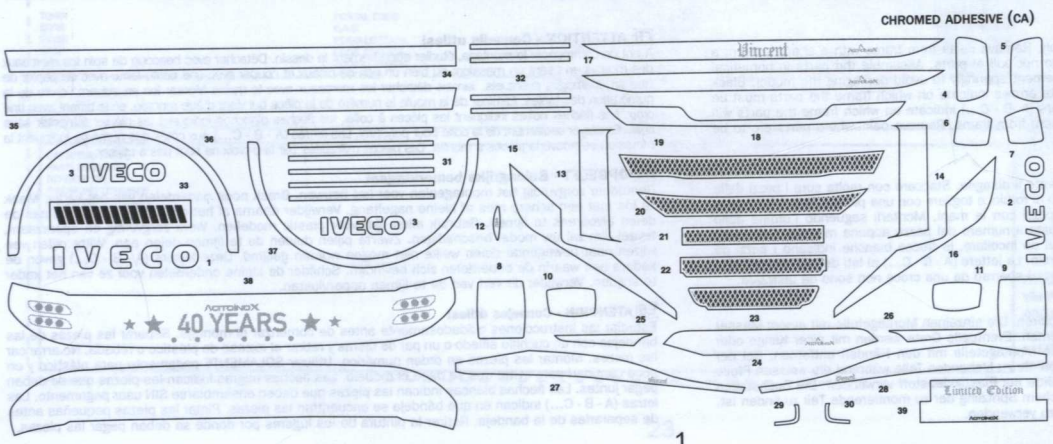
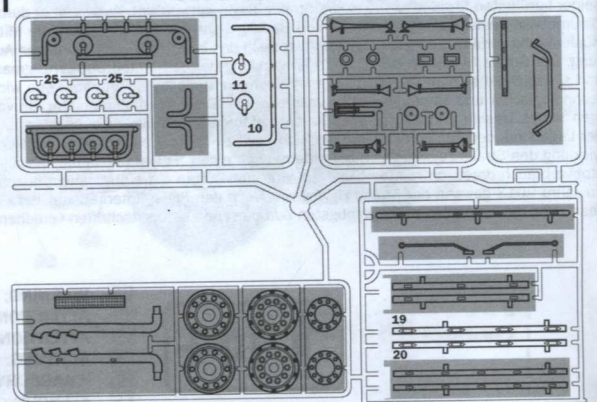

CHROMED ADHESIVE (CA)

TYRES 315/80 5X





TYRES 385/65 2X

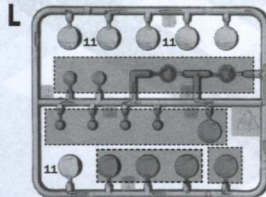
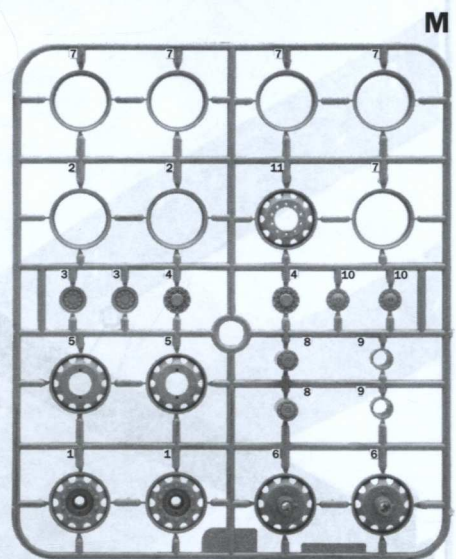
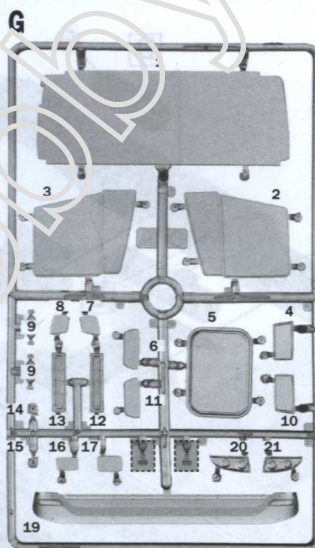
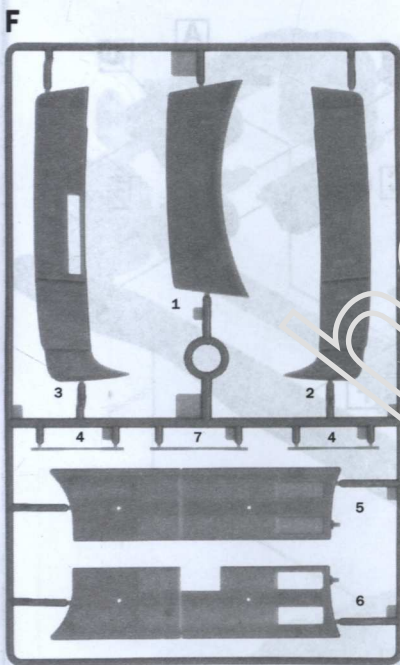
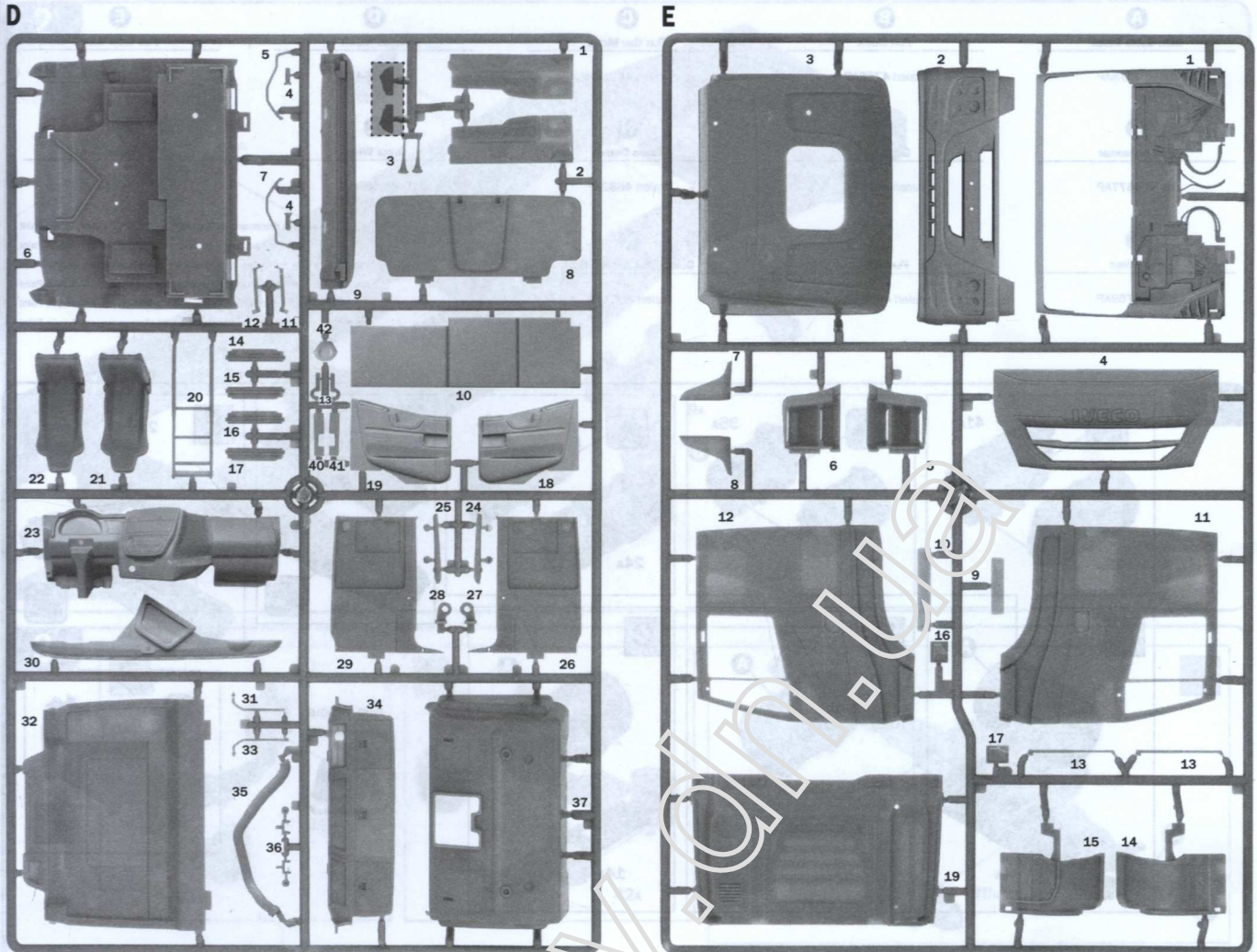





 Remove chrome paint where parts are to be glued together
 Raschiare la cromatura nei punti da incollare
 La peinture doit être retirée des portions à accoler
 Raspar el cromado de los puntos a encolar

 Aprire i fori
 Drill holes
 Ouvrir les trous
 Die Locher Ausbohren
 Perforar los agujeros
 Open gaten

 Aggiungere un peso
 Add weight
 Ajouter un poids
 Fügen Sie ein Gewicht
 Añadir un peso
 Voeg een gewicht

 Parti da non utilizzare
 Parts not for use
 Pièces à ne pas utiliser
 Telle werden niet verwendet
 Partes a no utilizar
 Onderdelen niet te gebruiken

 Ribadire a caldo
 Rivet hot
 Rivet à chaud
 Warm ennieten
 Reforzar al calor
 Versterking van hot

 Separare
 Cut
 Retirer
 Entfernen
 Separar
 Gesneden

A
MET. GLOSS SILVER

Italeri 4678AP

B
FLAT BLACK

Italeri 4768AP

C
FLAT GUN METAL

Italeri 4681AP

D
GLOSS YELLOW

Italeri 4642AP

E
FLAT LIGHT GRAY

Italeri 4765AP

F
FLAT ALUMINIUM

Italeri 4677AP

G
GLOSS RED

Italeri 4605AP

H
GLOSS ORANGE

Italeri 4682AP

I
GLOSS WHITE

Italeri 4696AP

J
FLAT MEDIUM GRAY

Italeri 4746AP

L
FLAT WHITE

Italeri 4769AP

M
FLAT RED

Italeri 4606AP

K
GLOSS (BLUE ANGELS) BLUE

Italeri 4687AP

I numeri si riferiscono all'assortimento colori Italeri Acrylic Paint
The indicated colour number refer to the Italeri Acrylic Paint
Les références indiquées concernent les peintures Italeri Acrylic Paint
Die angegebenen farbnummern beziehen sich auf die Italeri Acrylic Paint
Los números se refieren a los colores surtido Italeri Acrylic Paint
De nummers verwijzen naar het assortiment kleuren Italeri Acrylic Paint

1

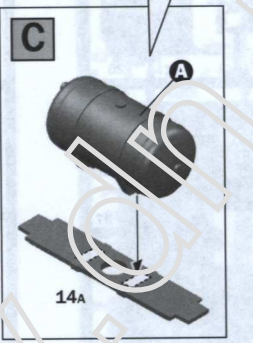
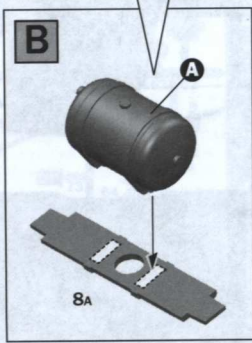
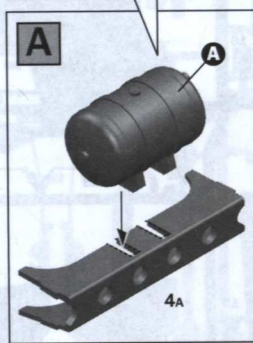
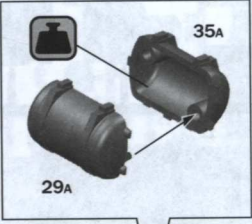

ADD WEIGHT

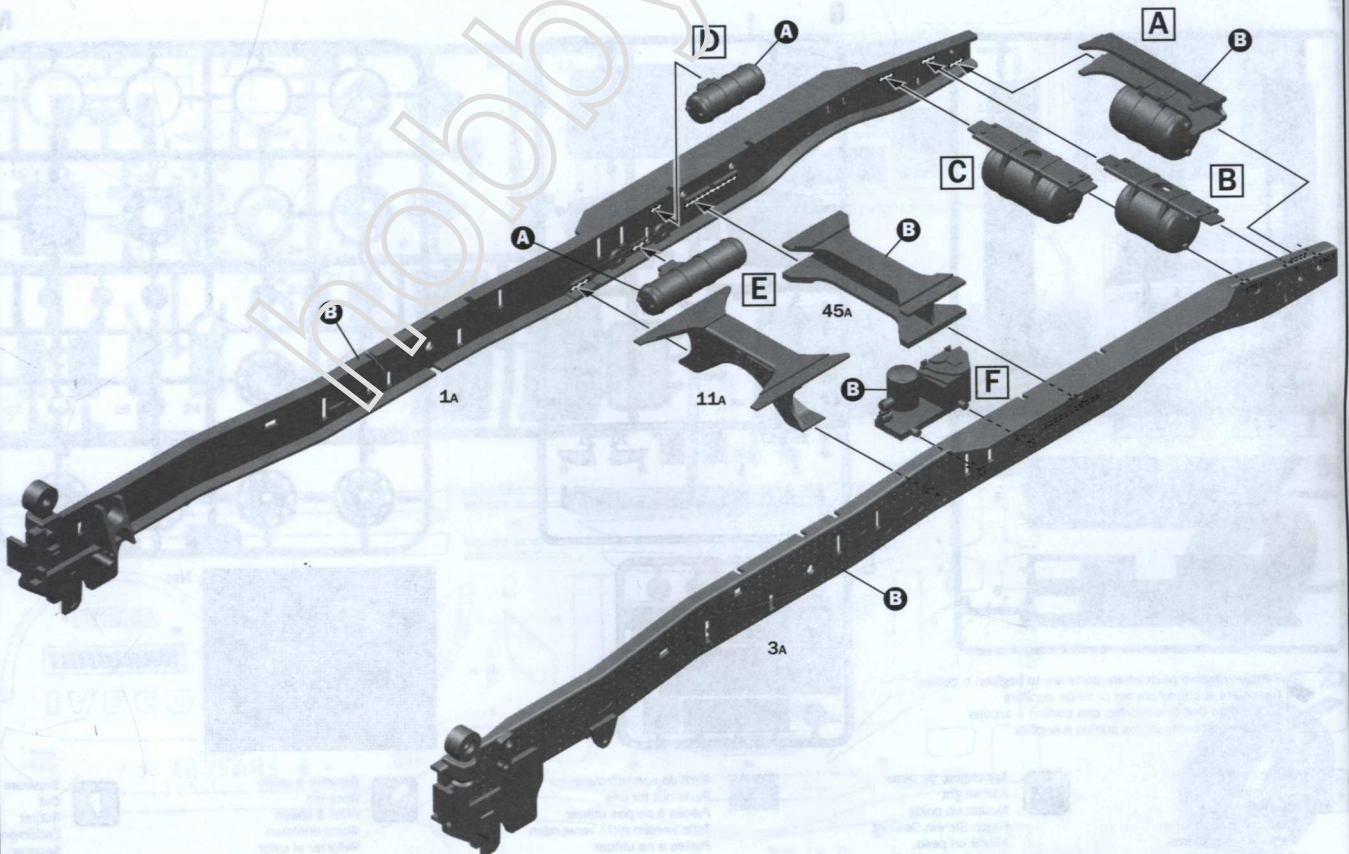
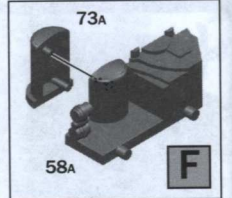

2

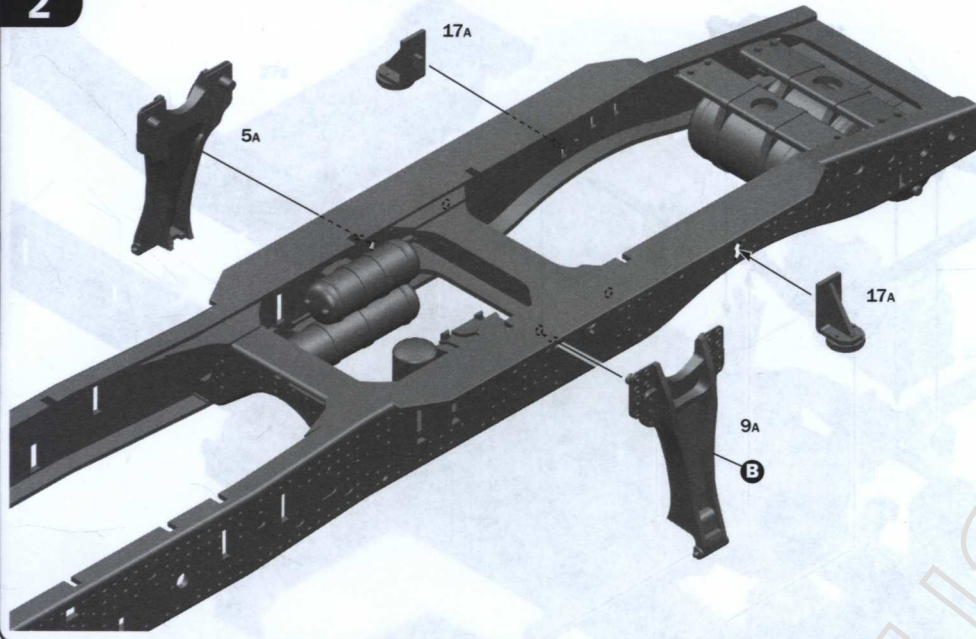

3

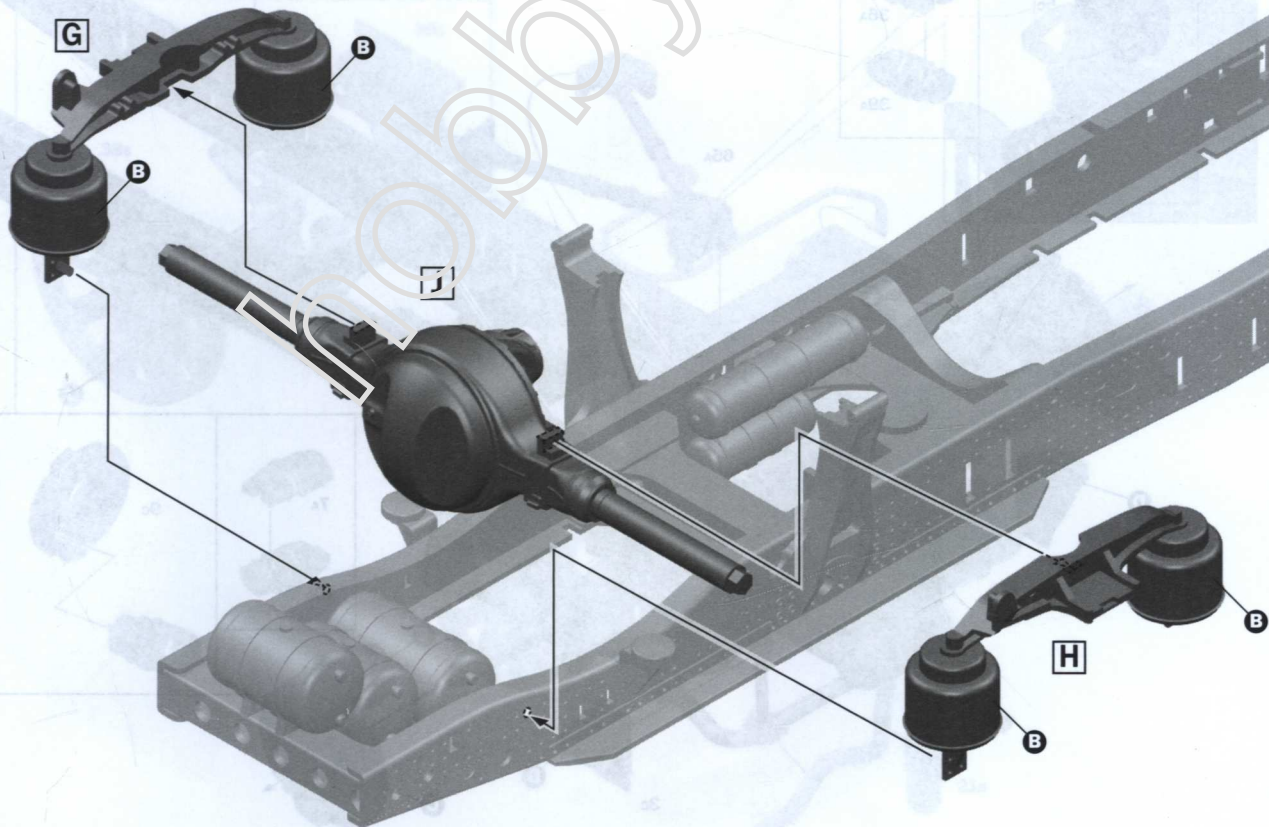
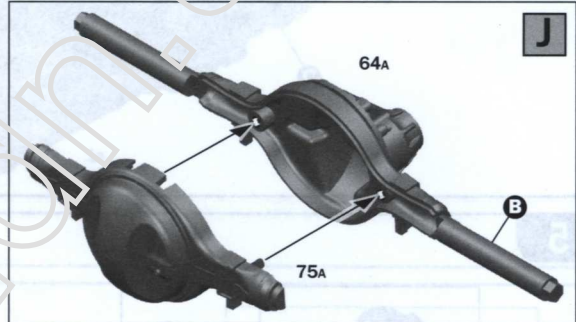
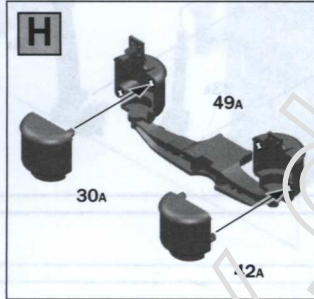
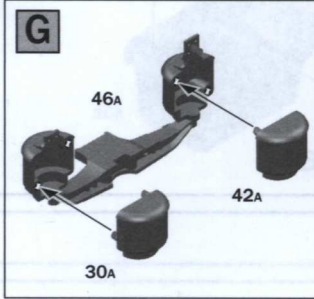

4

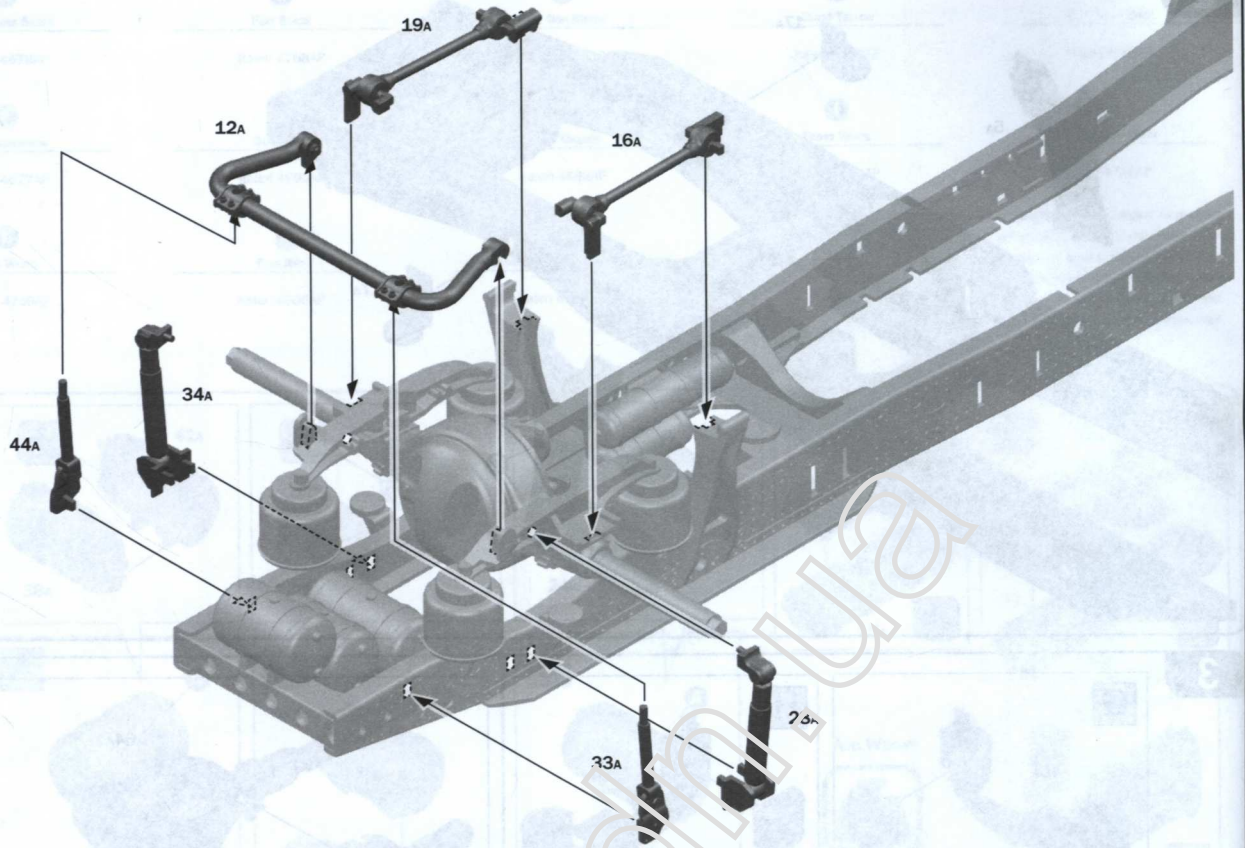

5

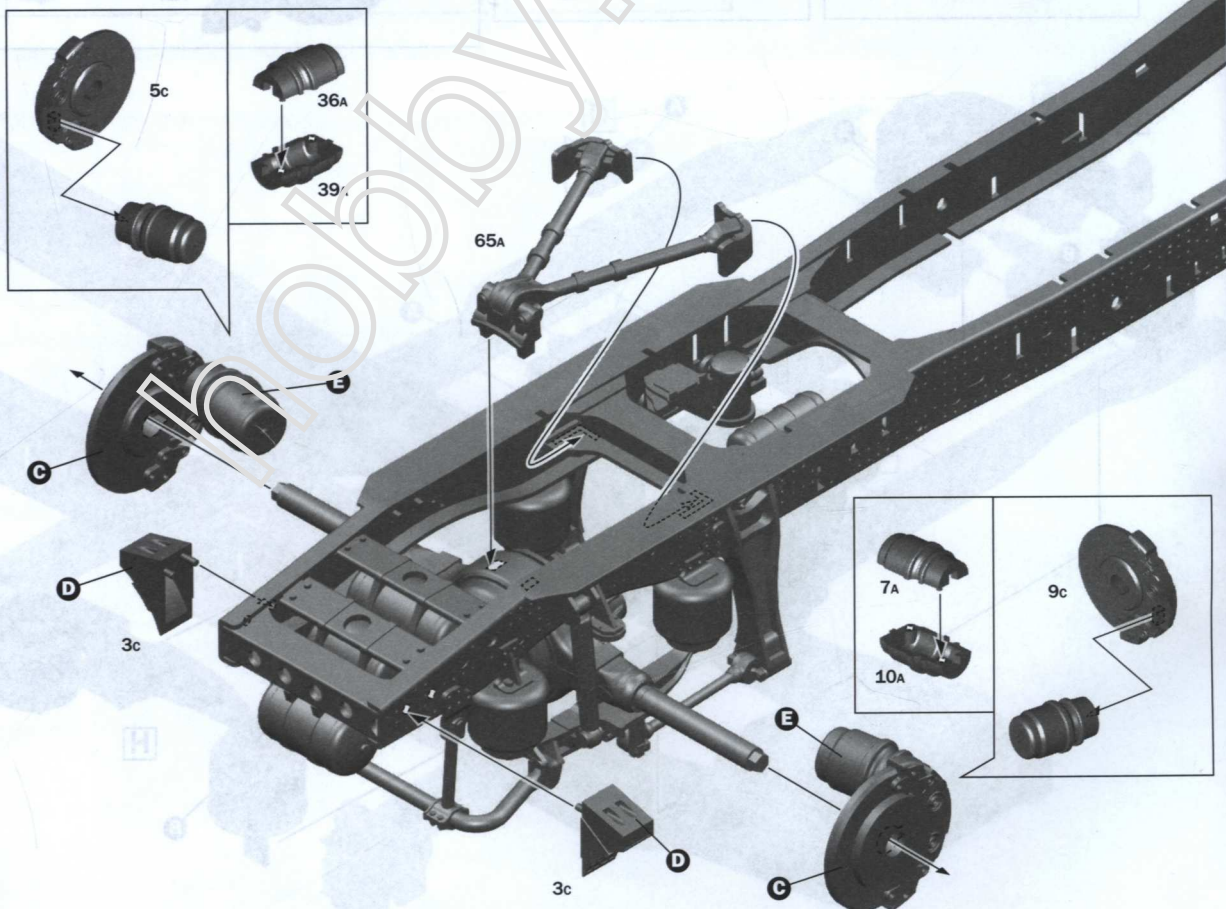

6

8

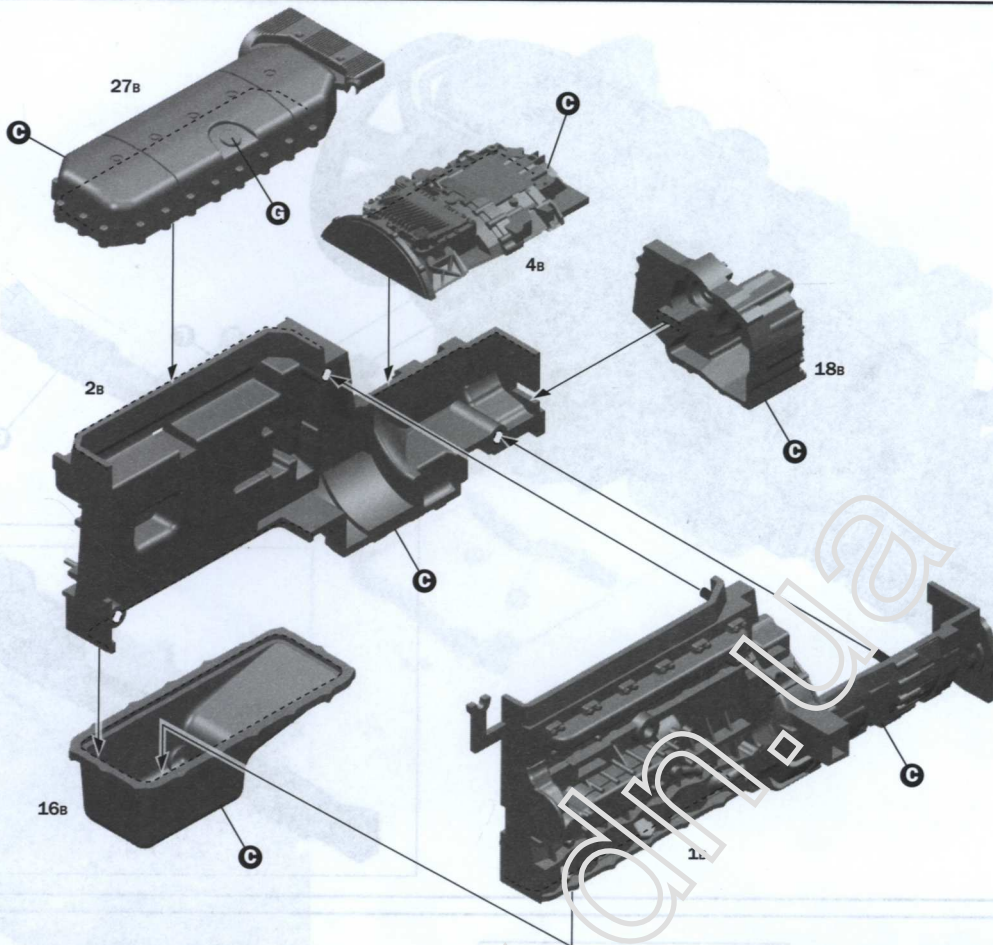

7

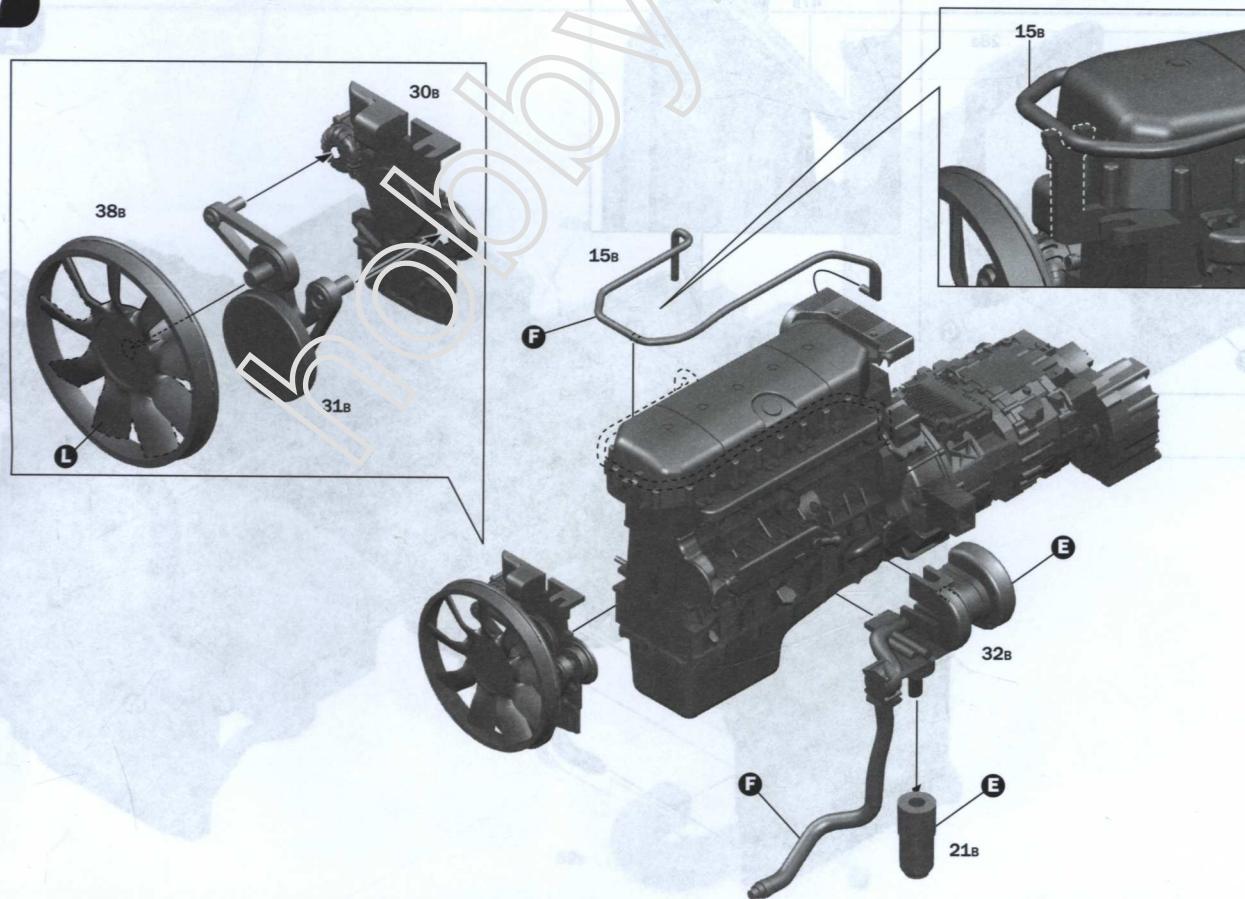

8

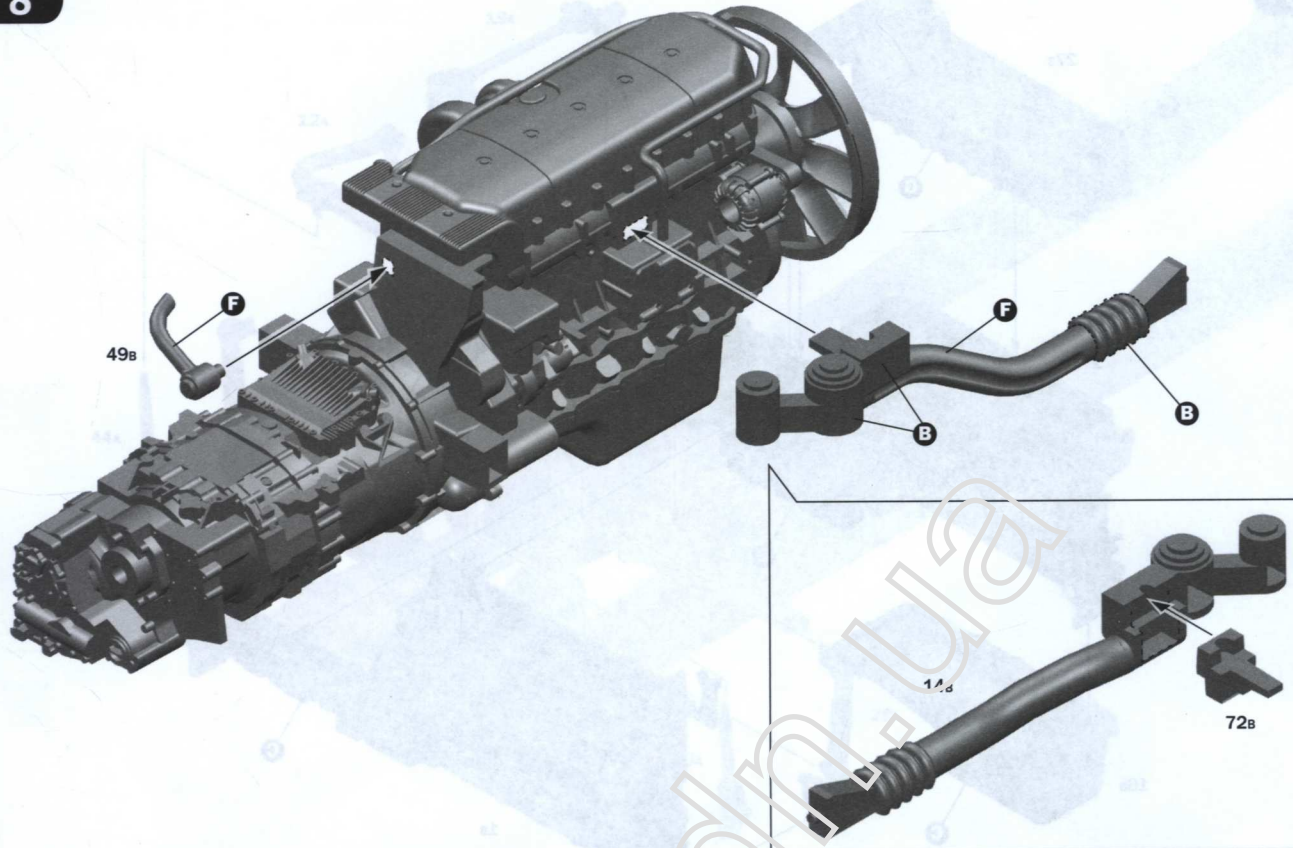

9

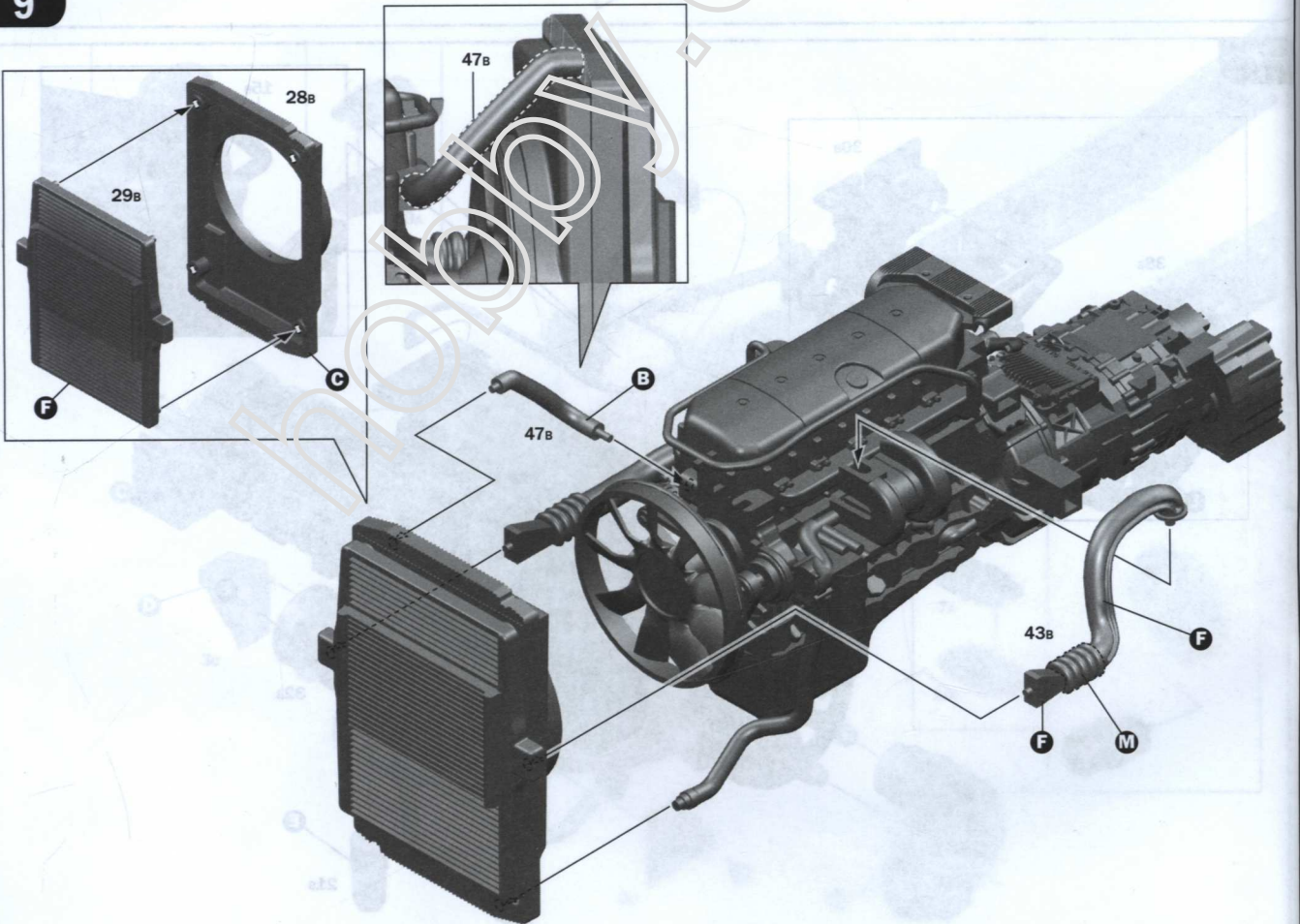

10

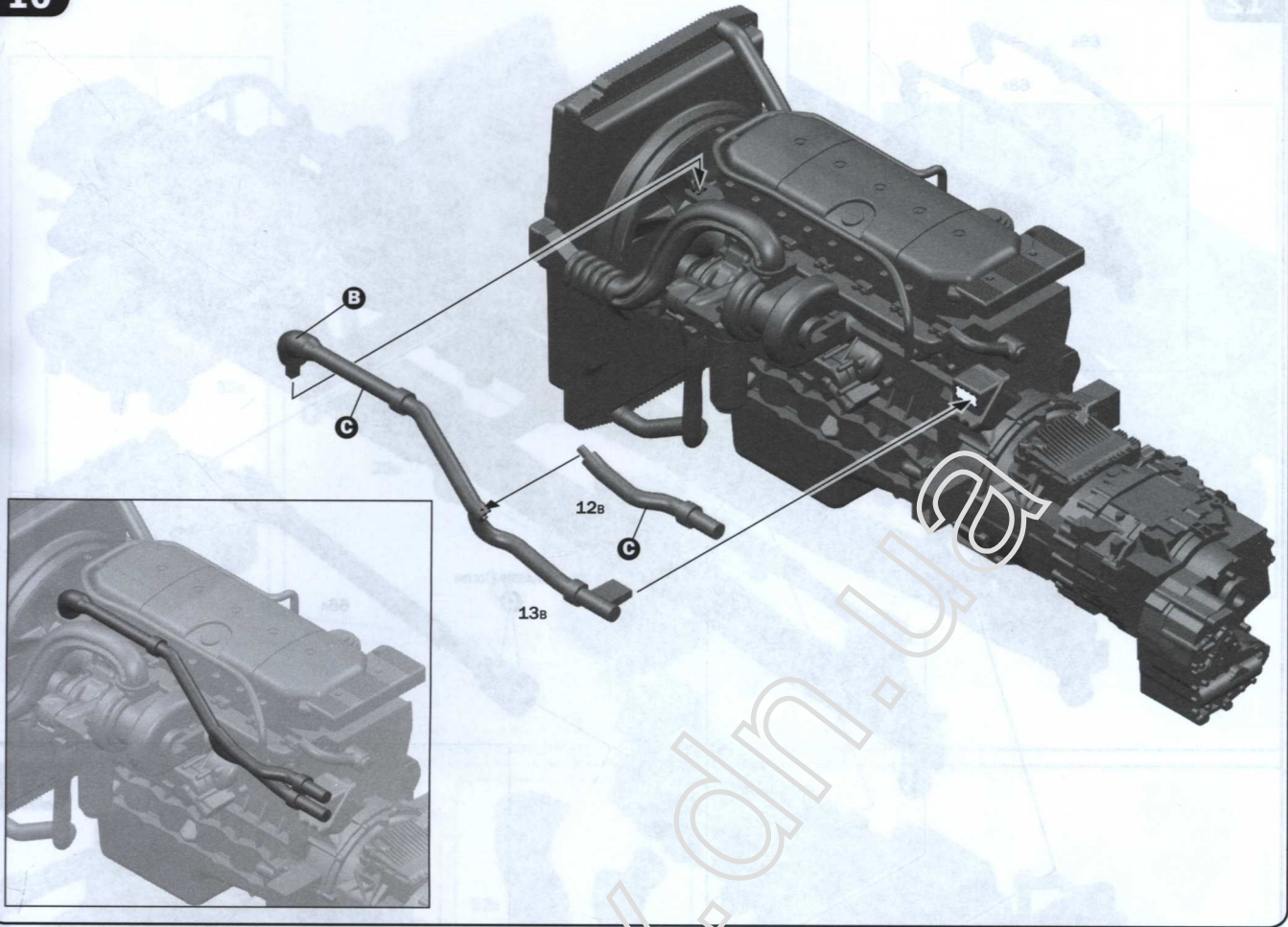

11

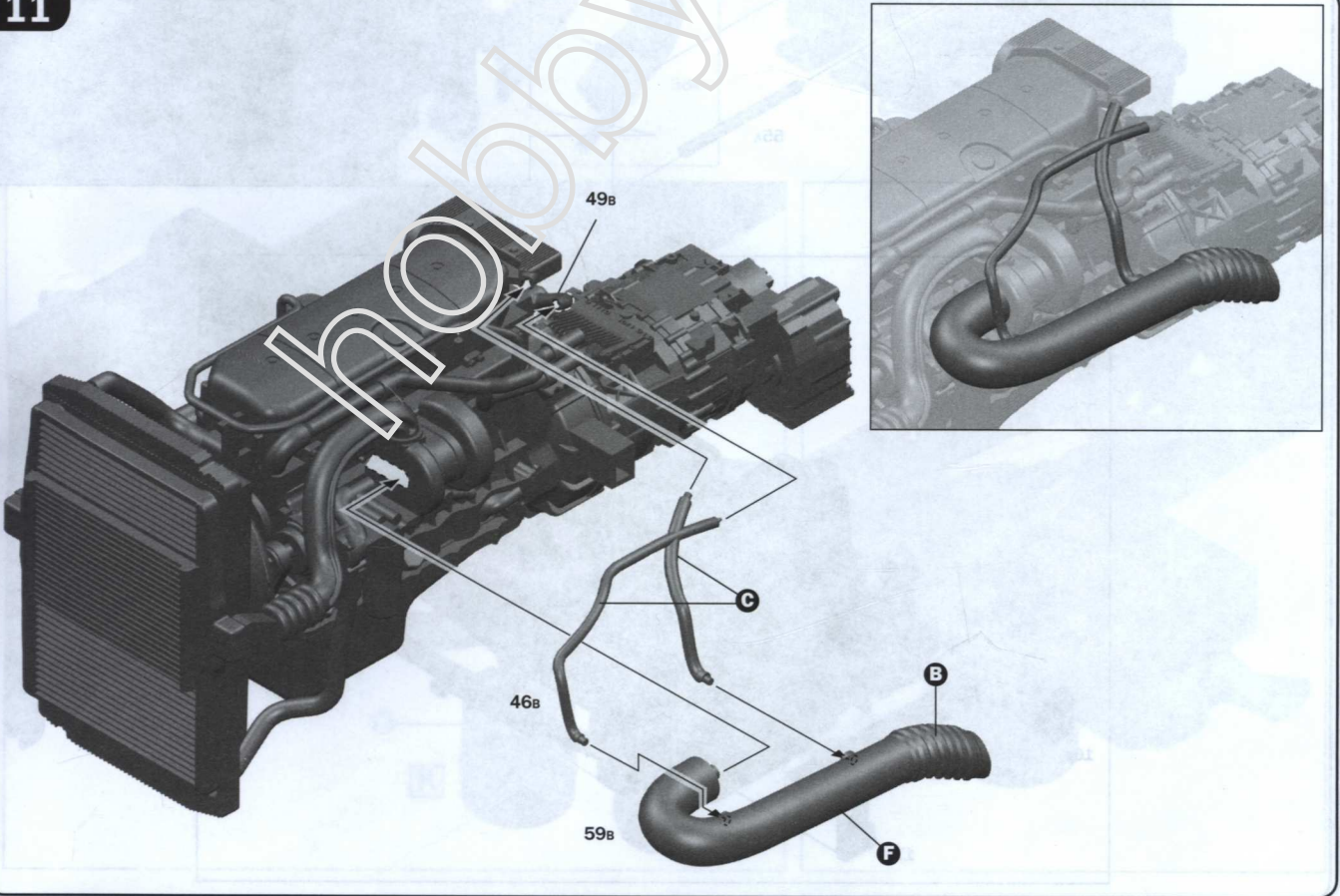

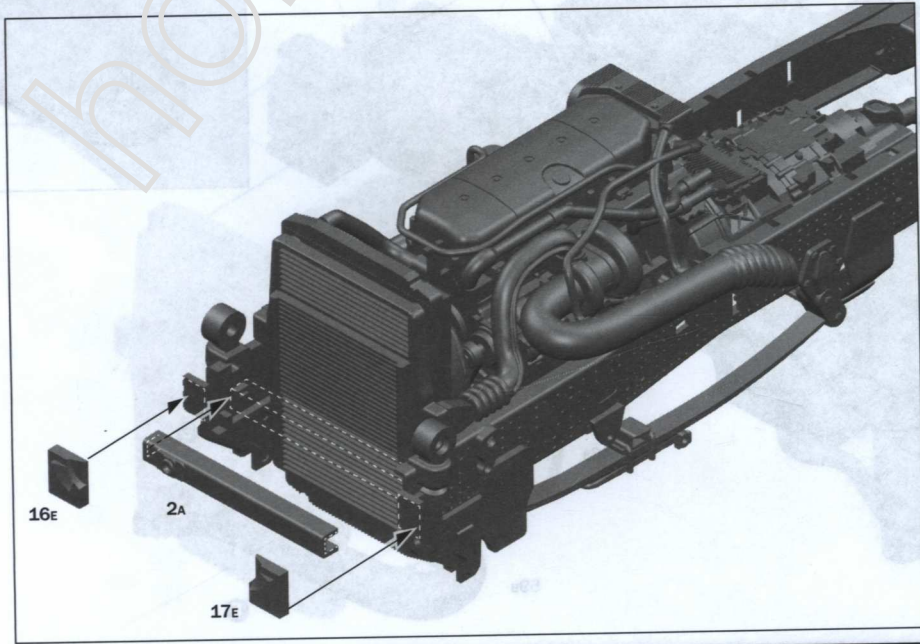
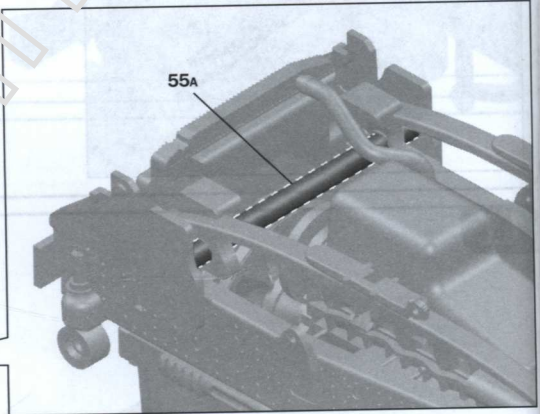
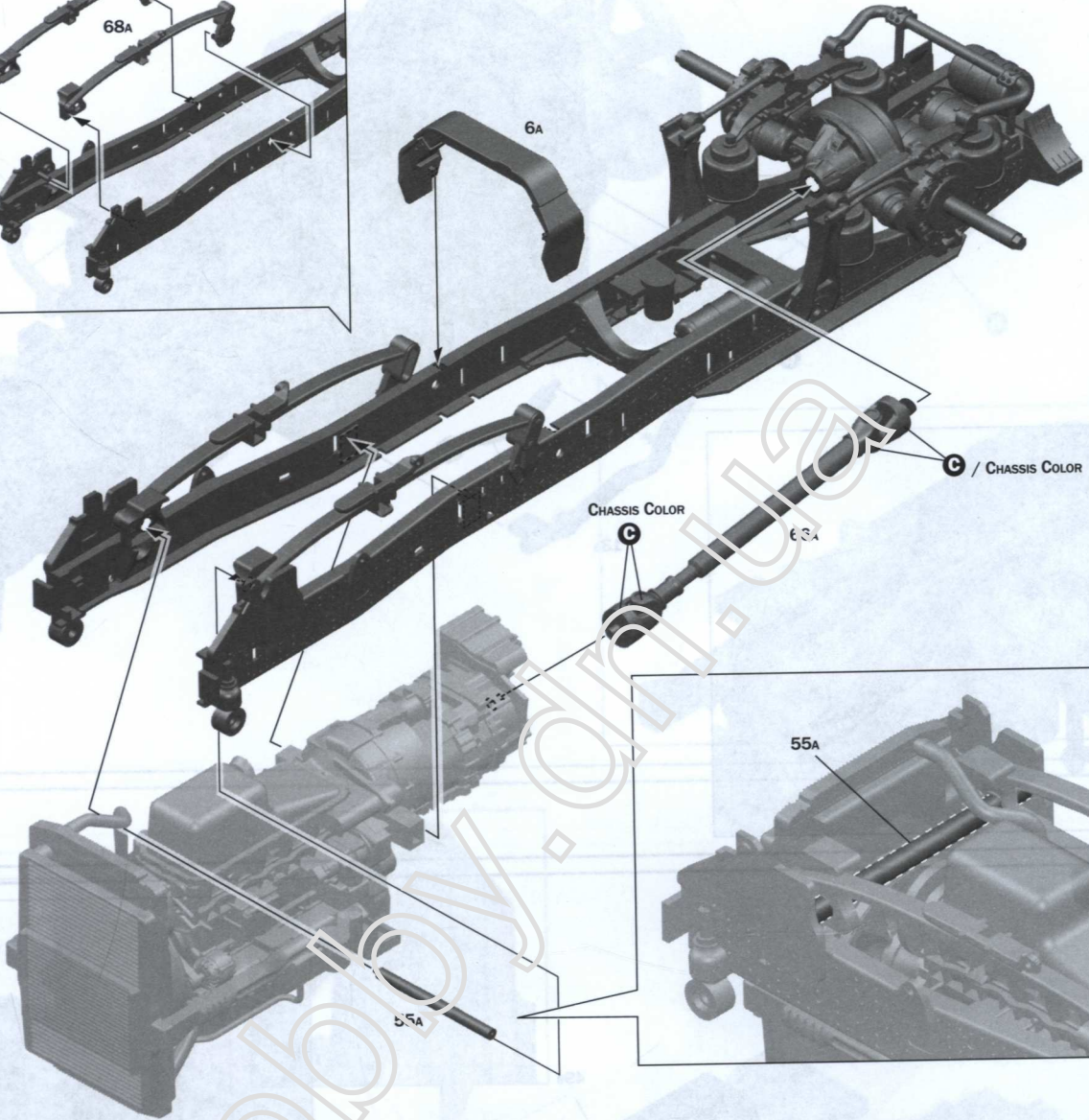
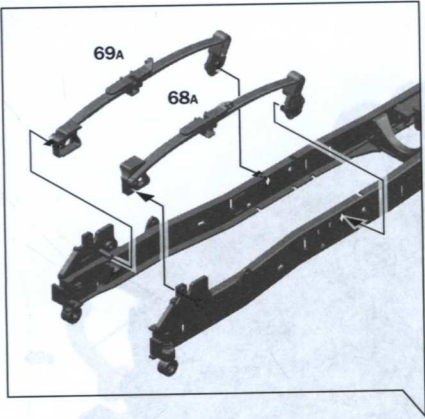

13

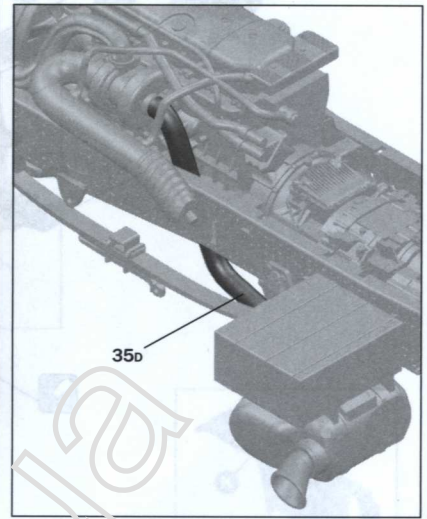
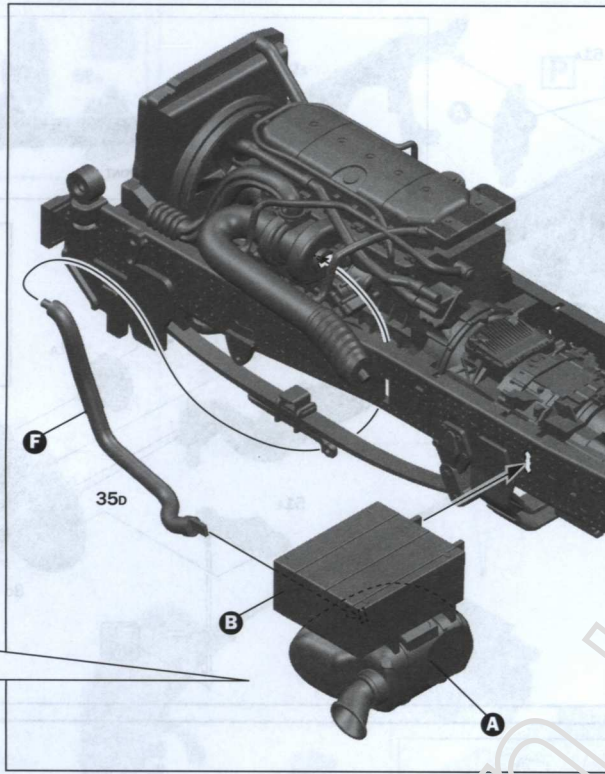

14

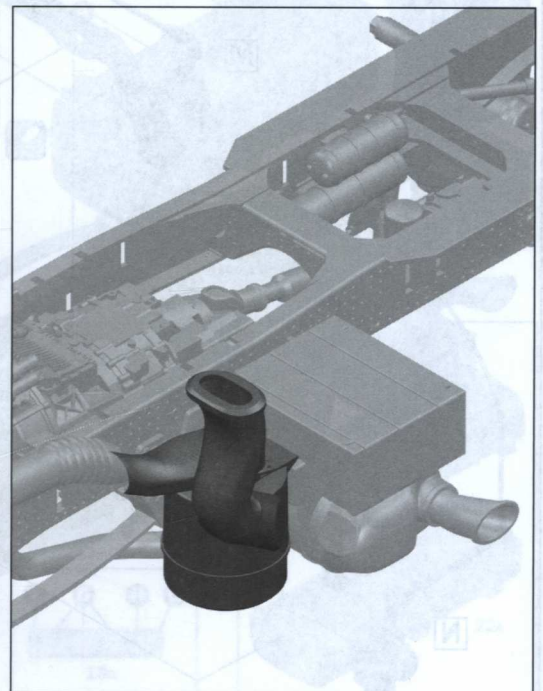
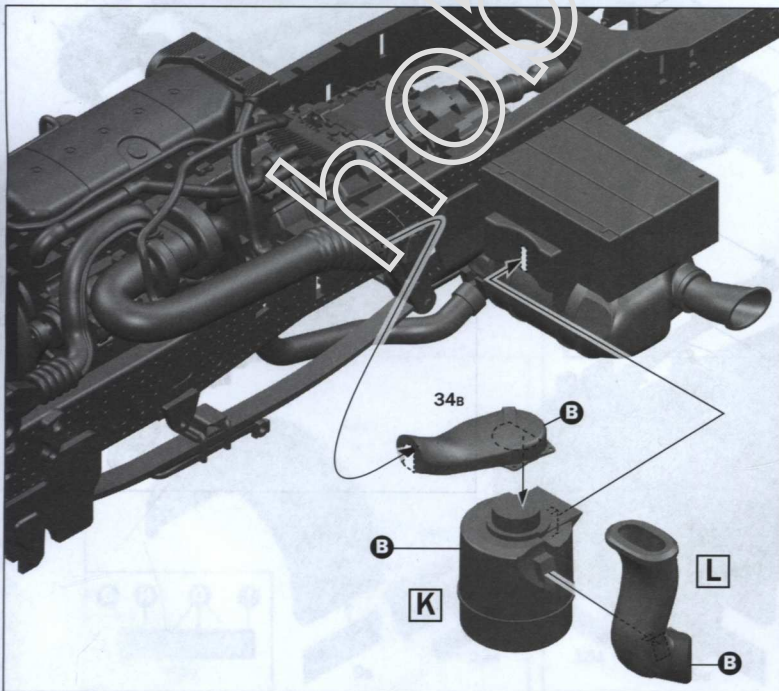
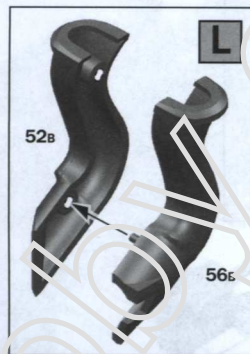
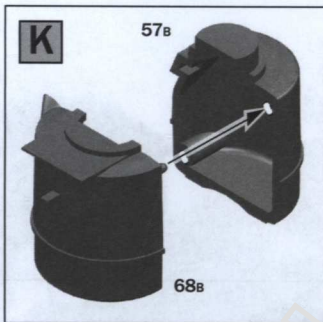

15

M

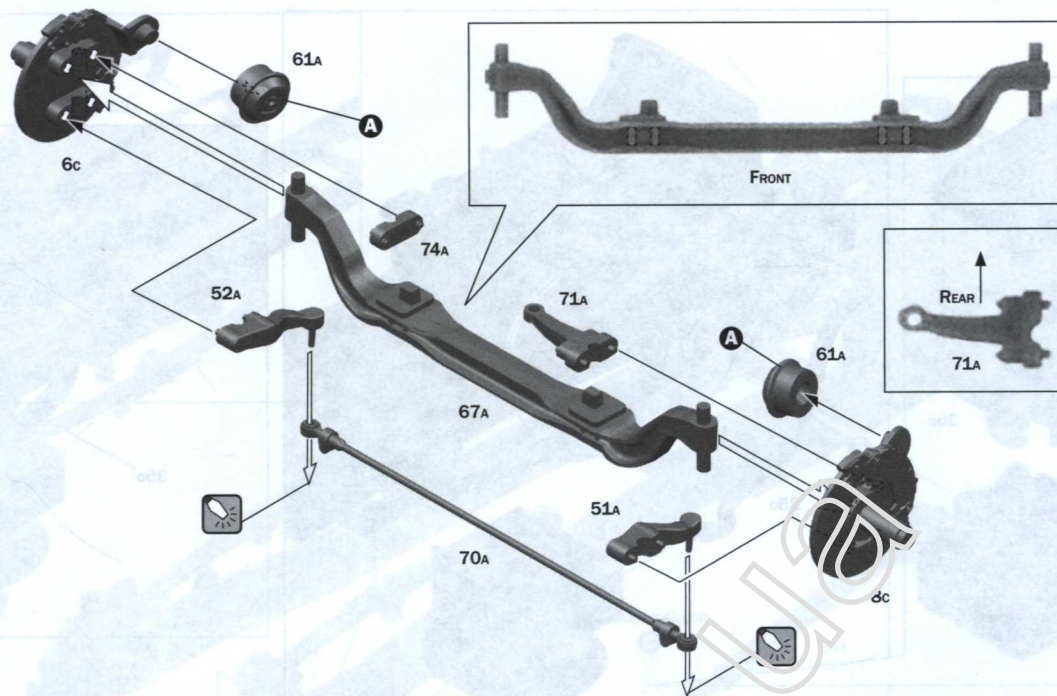

16

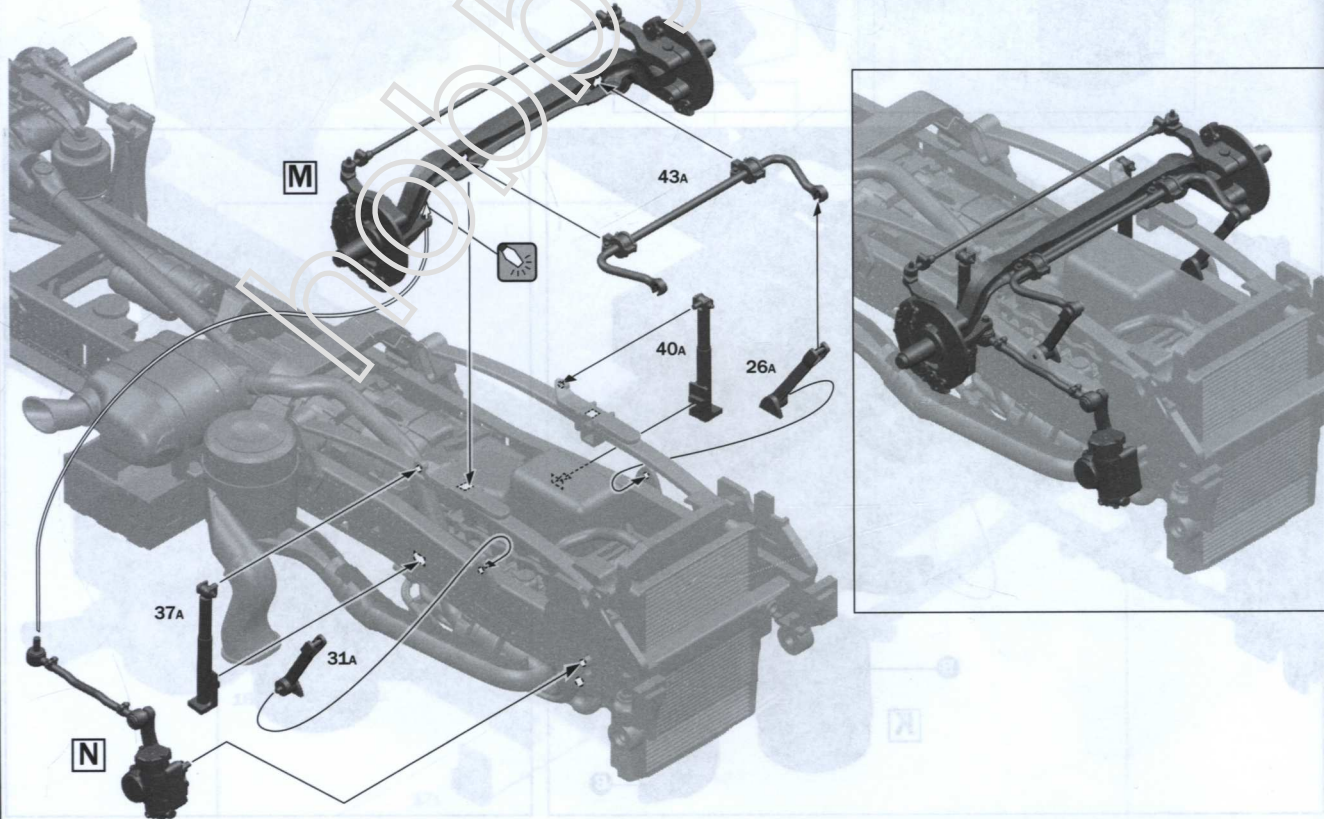
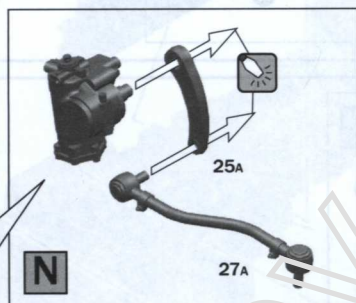
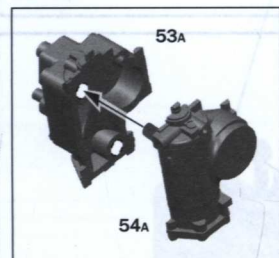

18

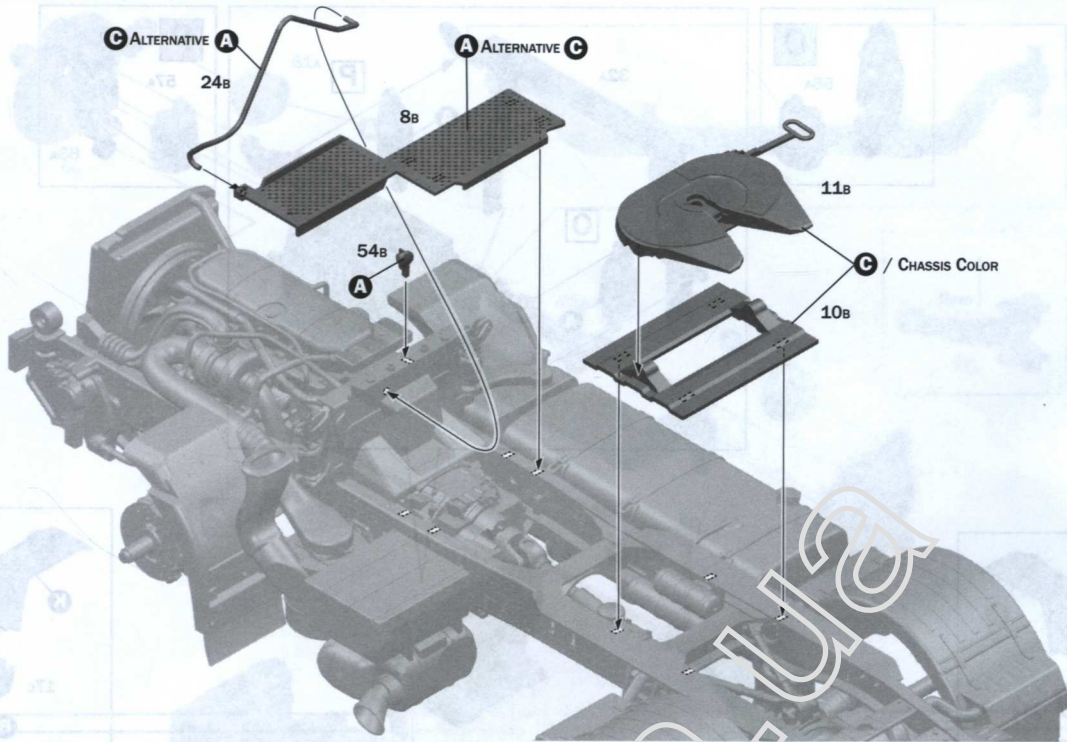

19

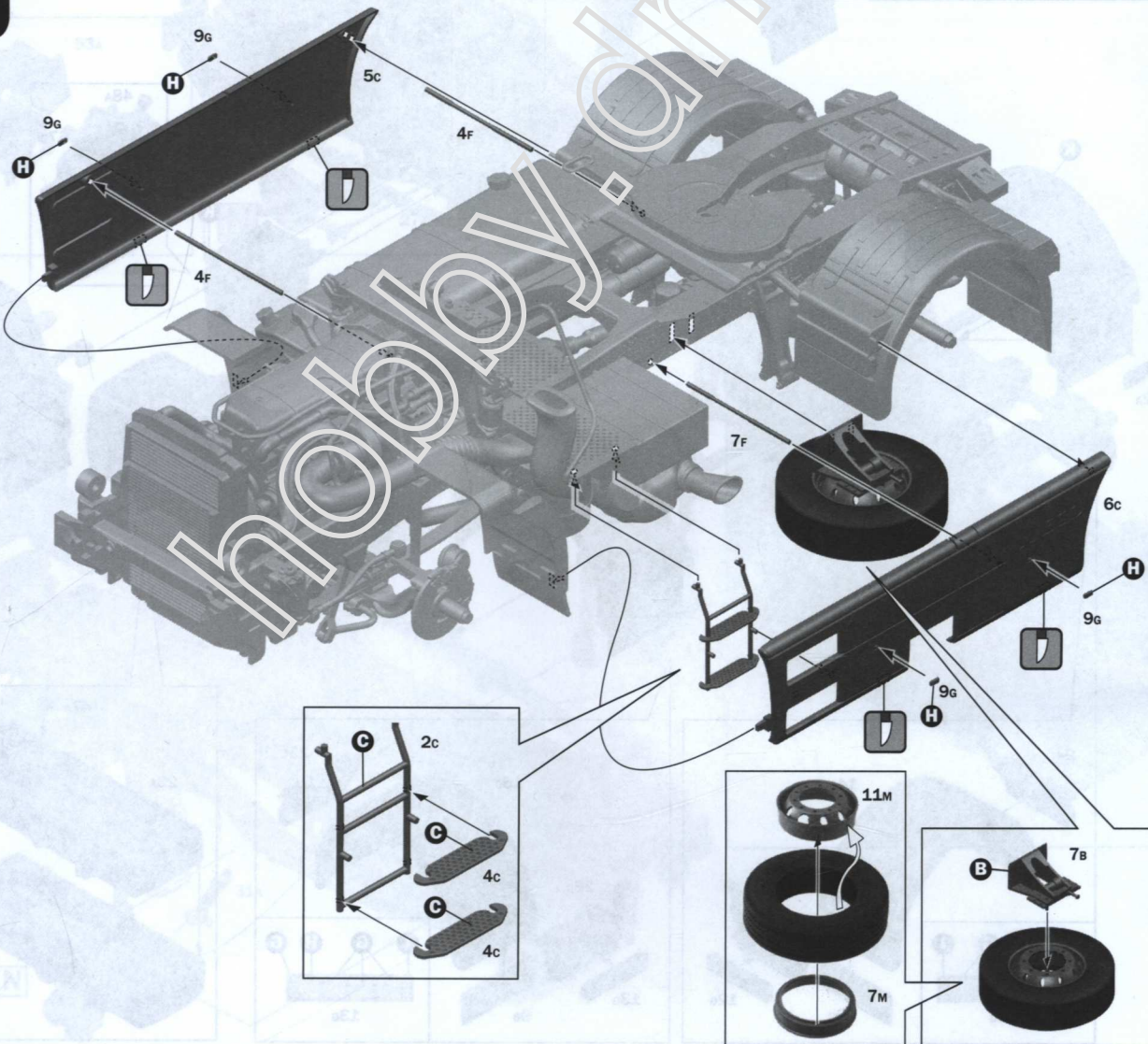

20

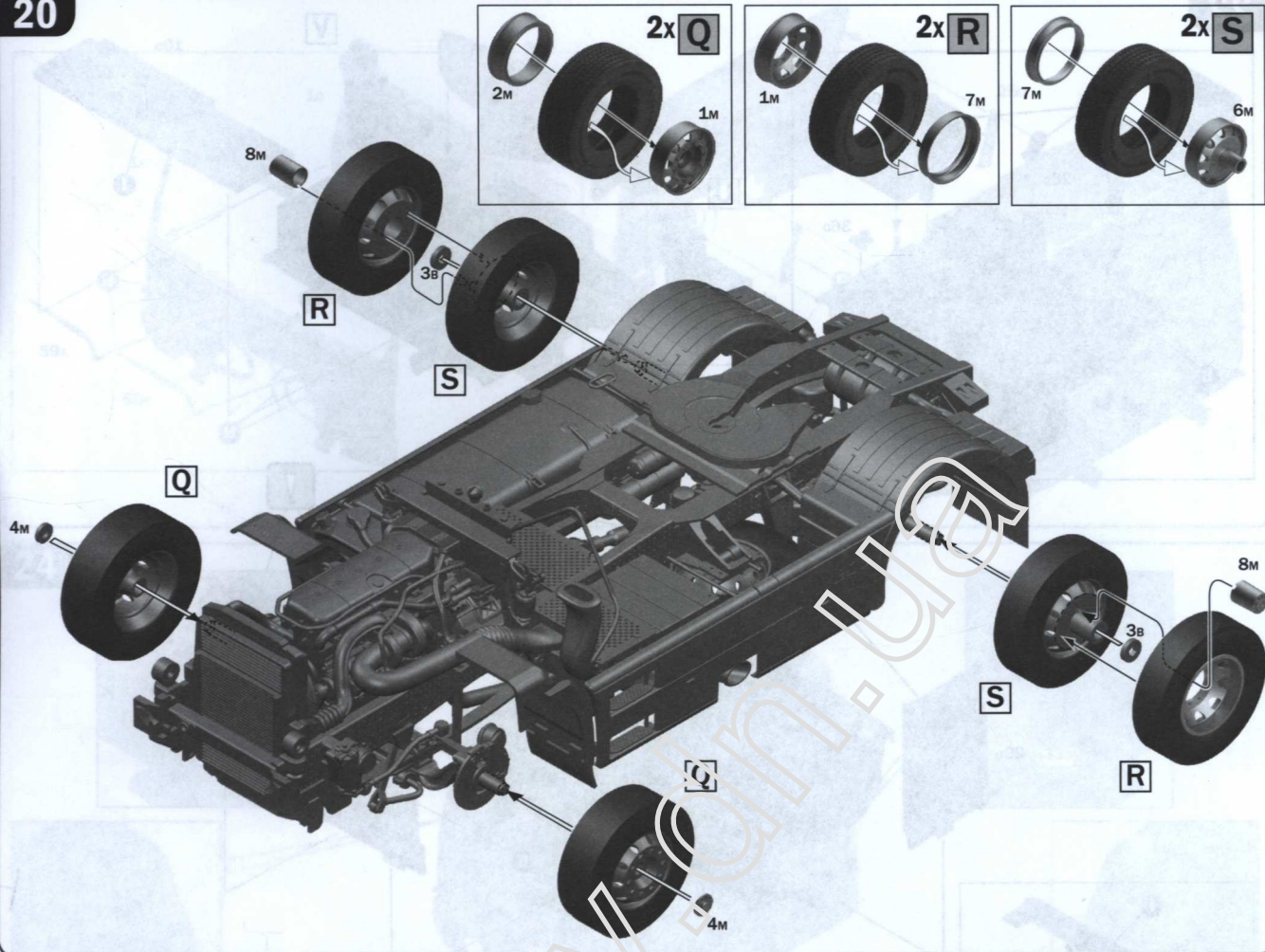

21

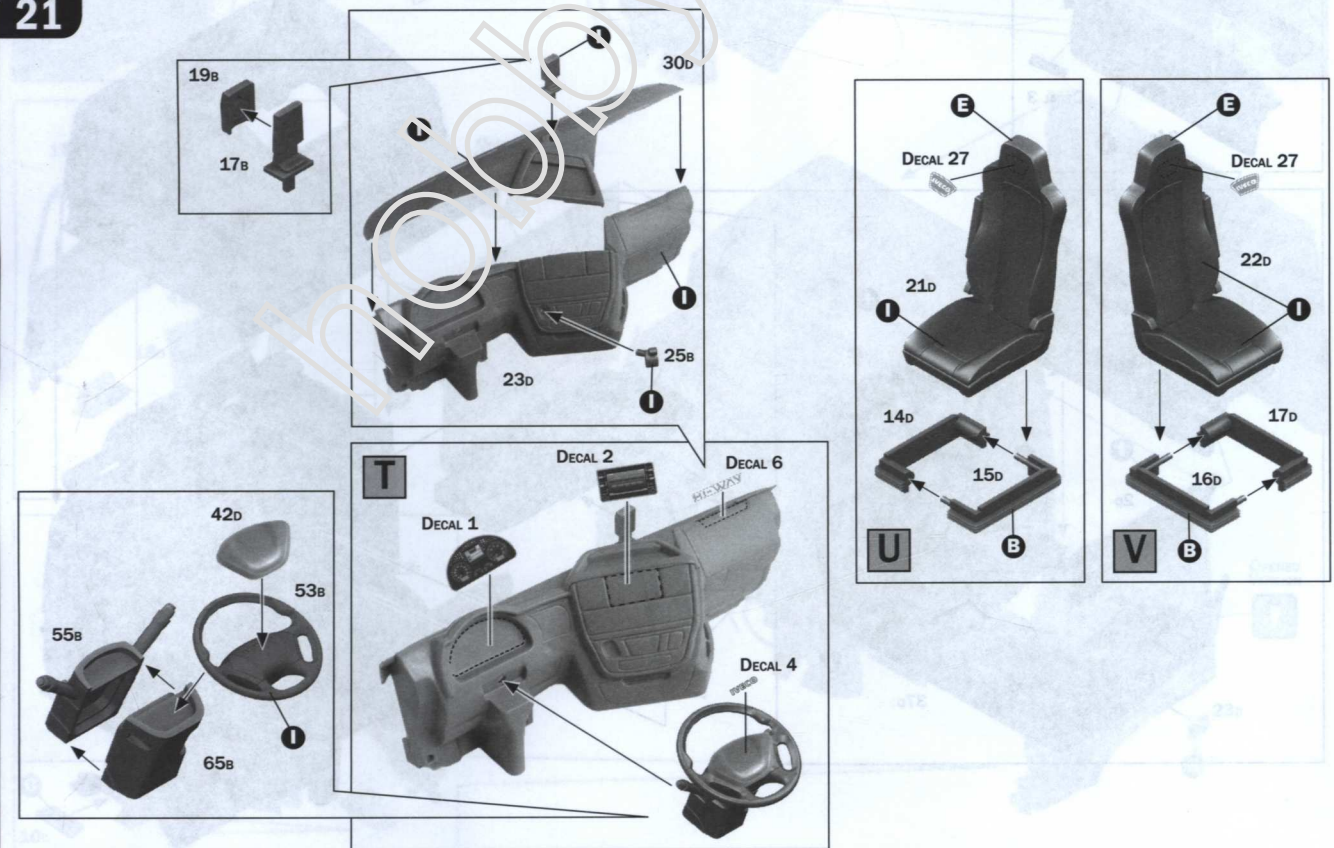

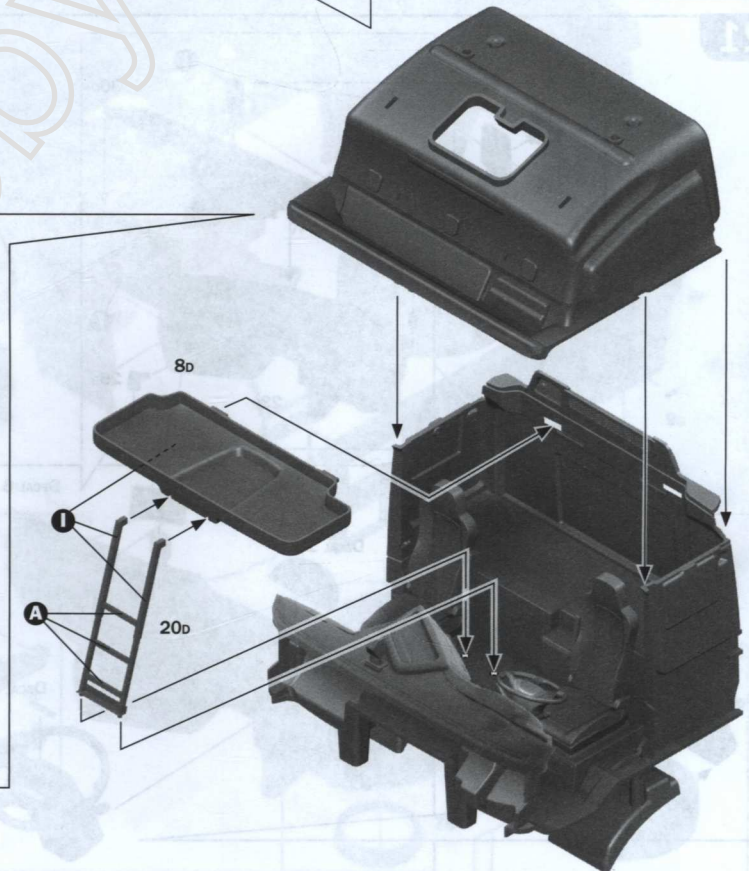
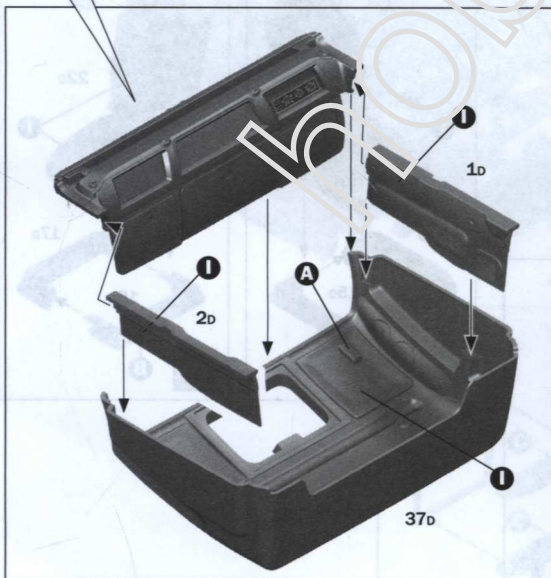
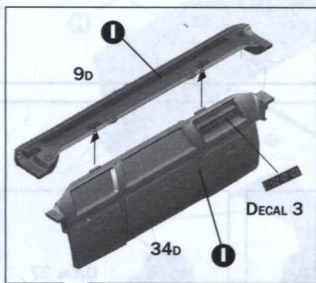
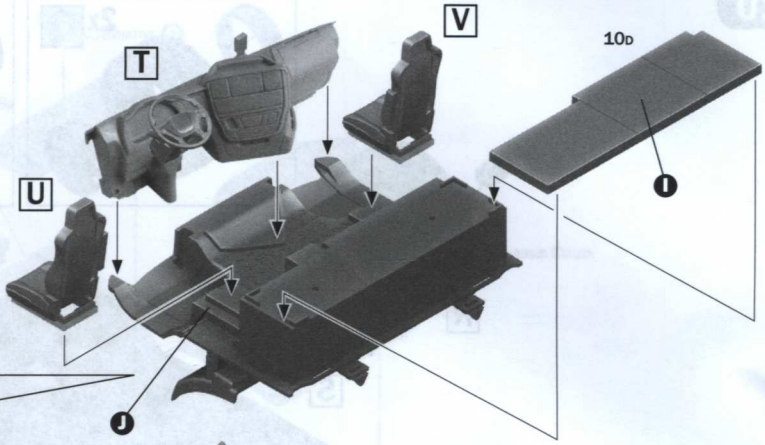
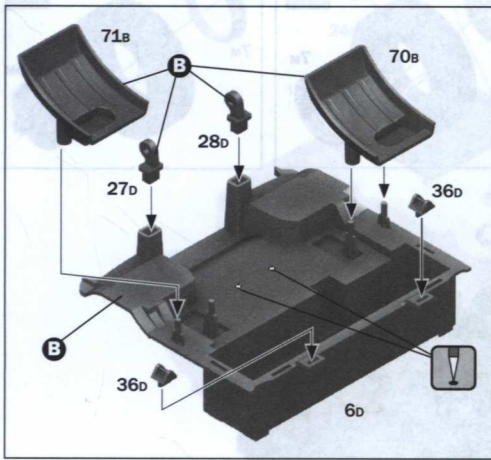

23

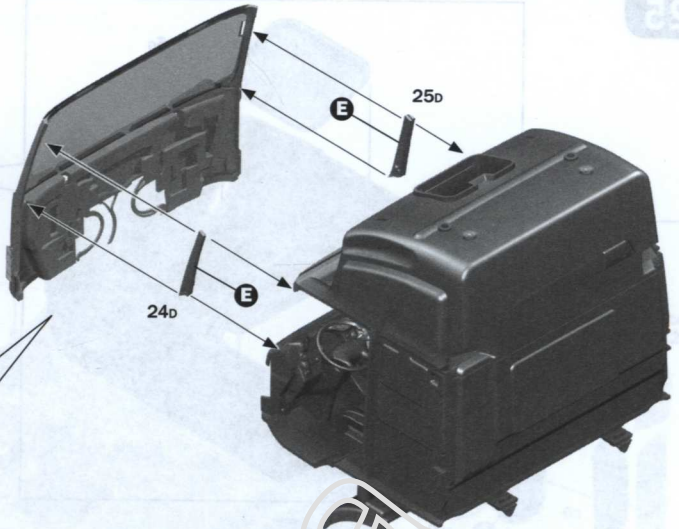
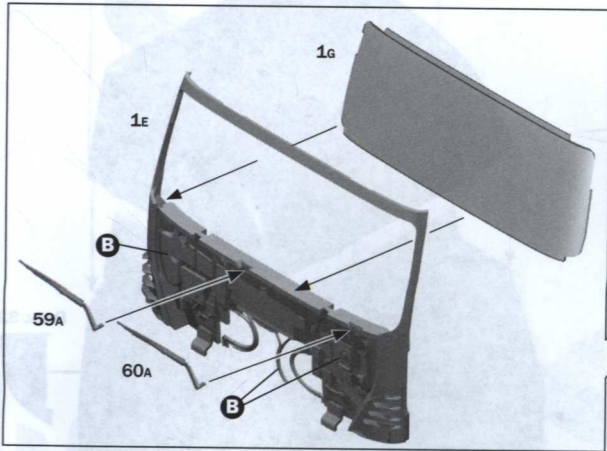

24

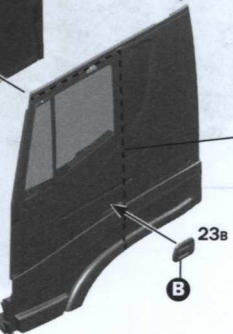
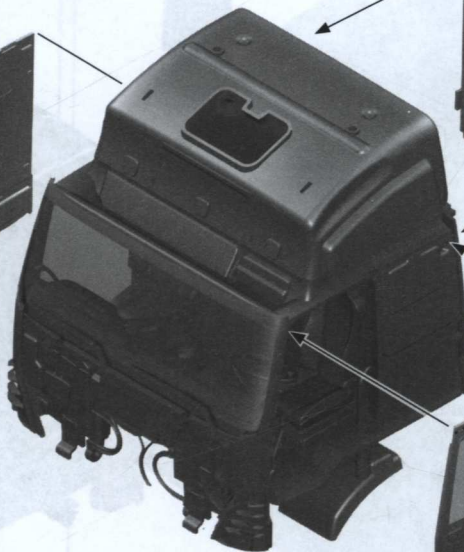
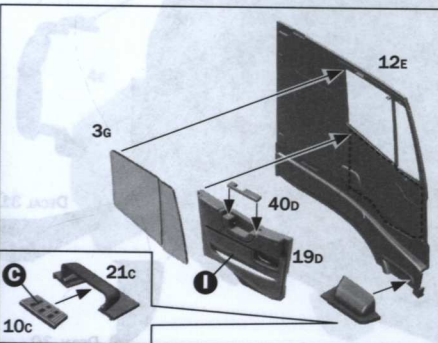
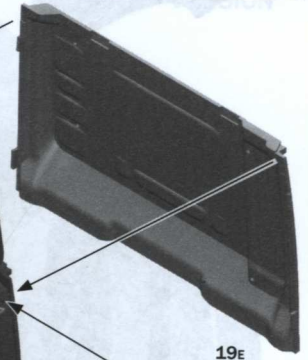
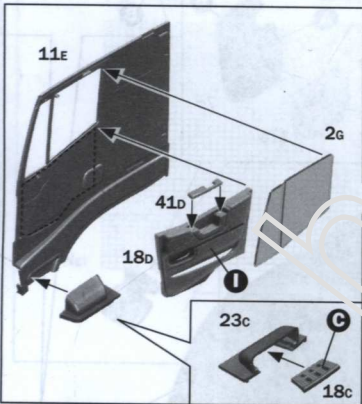
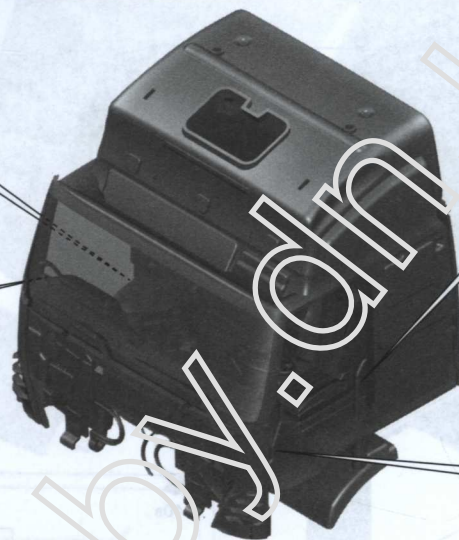
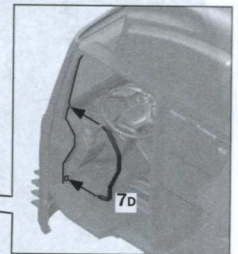
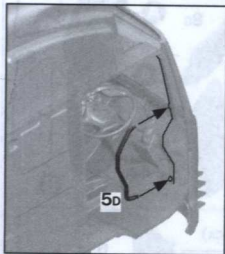
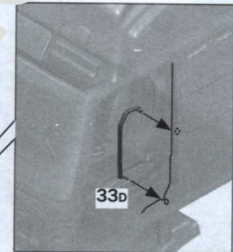
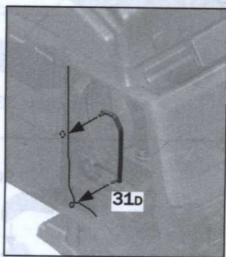

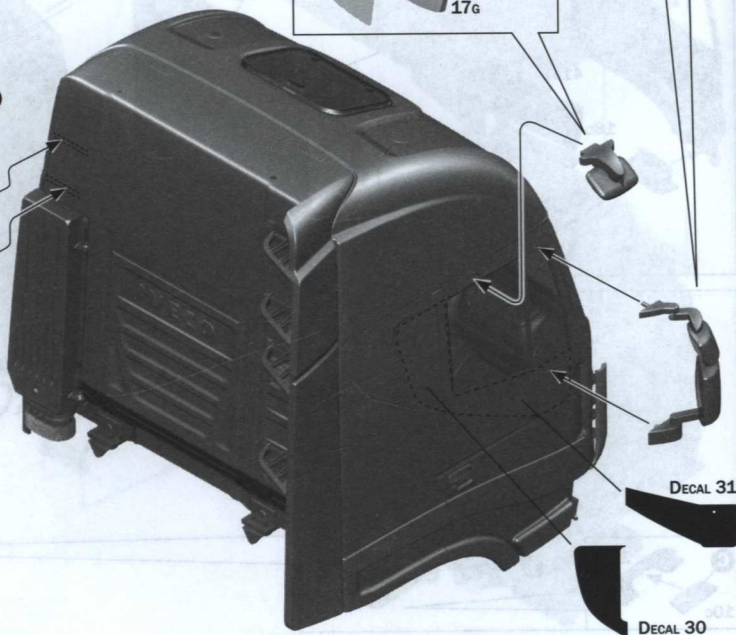
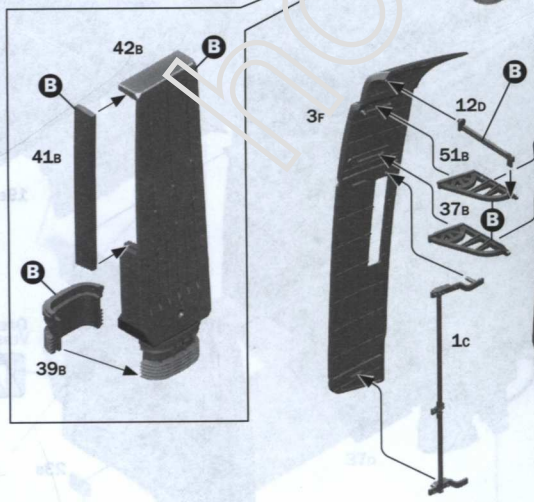
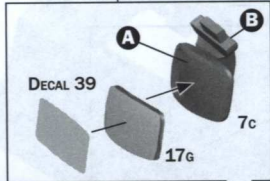
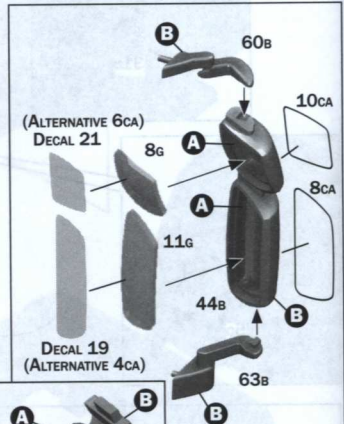
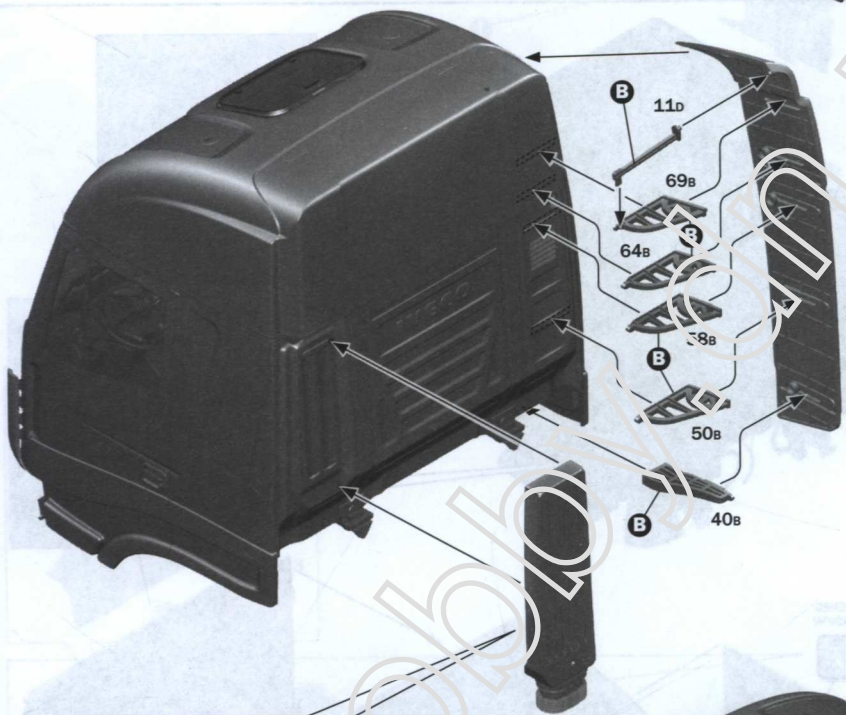
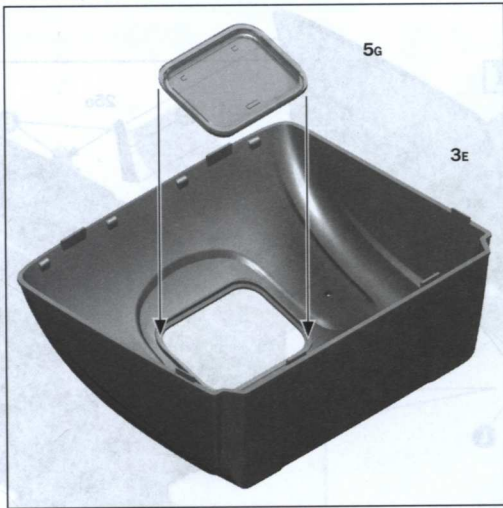

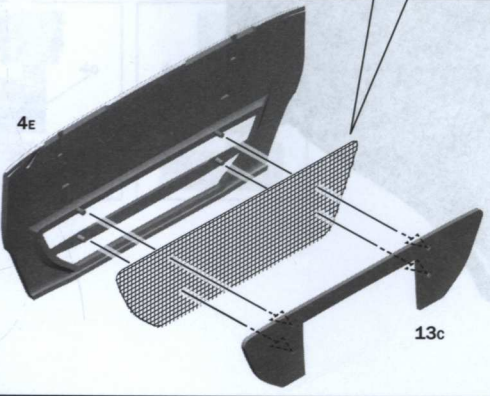
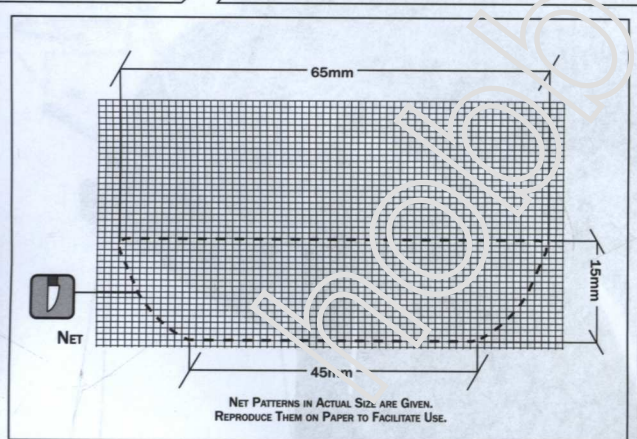
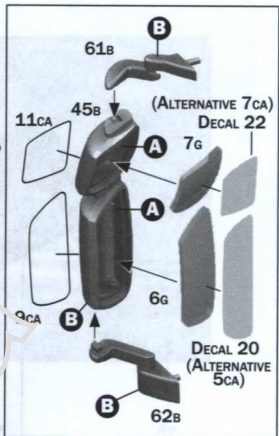
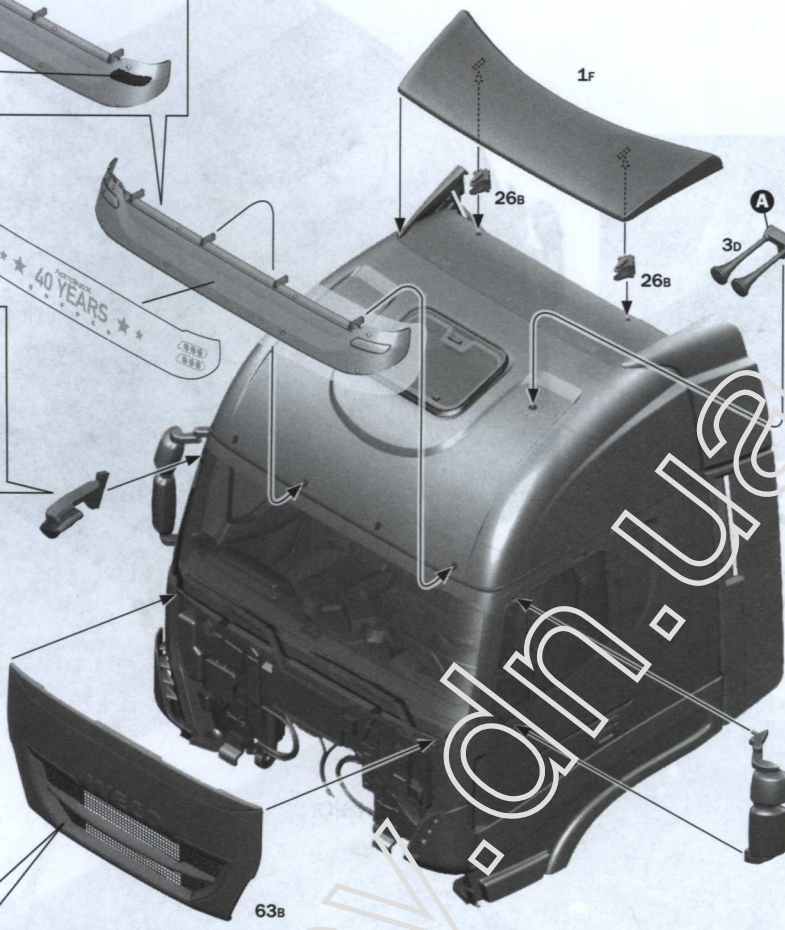
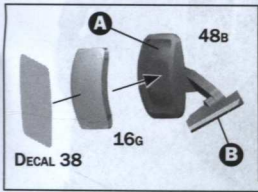
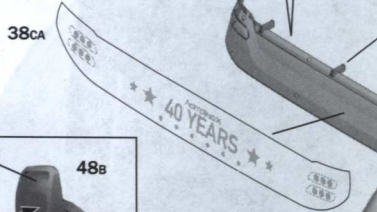
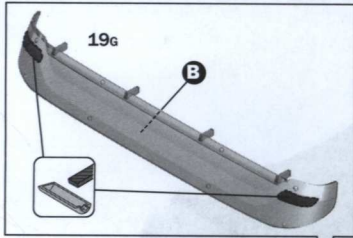

CLOSED VERSION



ALTERNATIVE

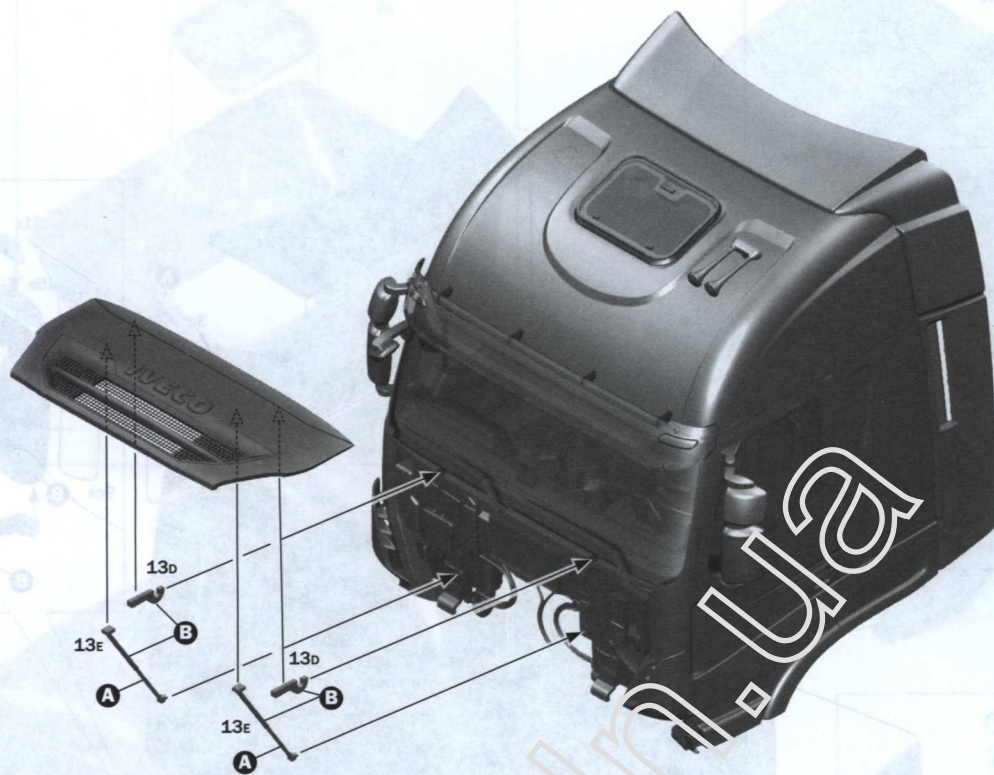

OPENED VERSION





GLUE IN POSITION WITH CARE

4d

4d

GLUE IN POSITION WITH CARE

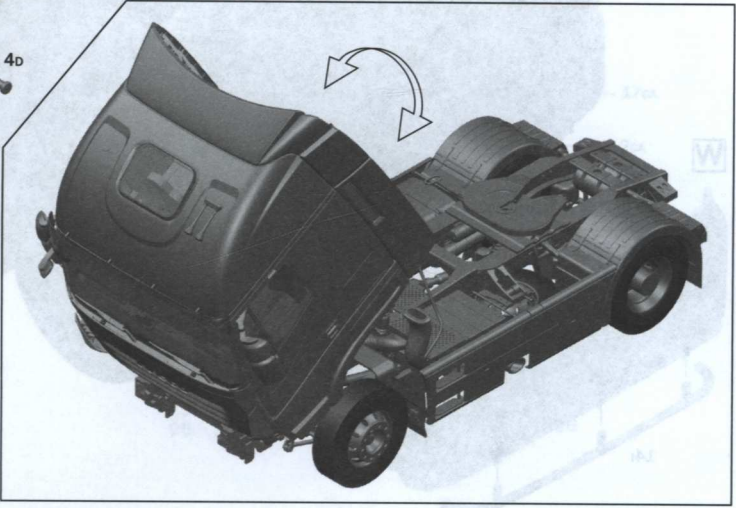
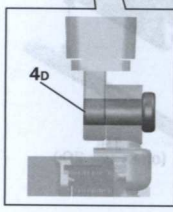
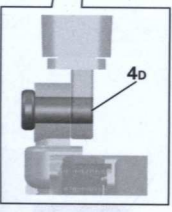

29

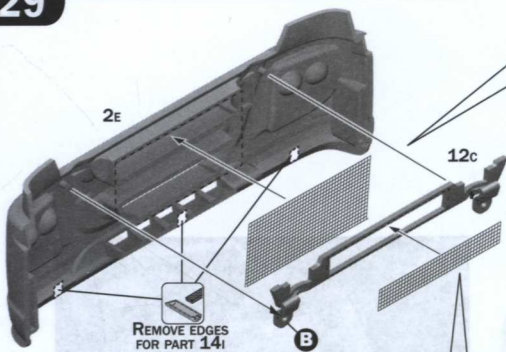

NET PATTERNS IN ACTUAL SIZE ARE GIVEN. REPRODUCE THEM ON PAPER TO FACILITATE USE.

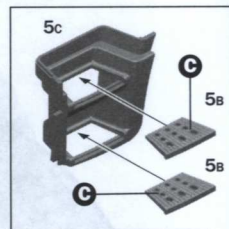
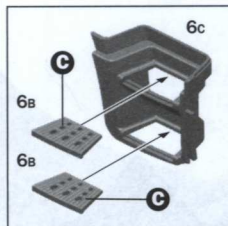
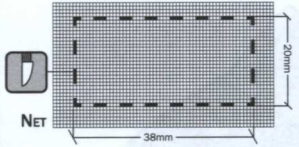

W

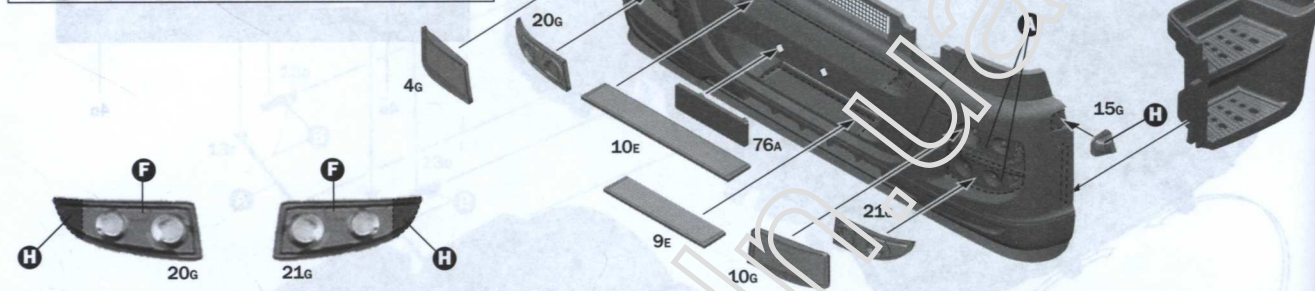
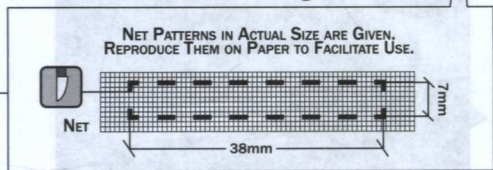

30

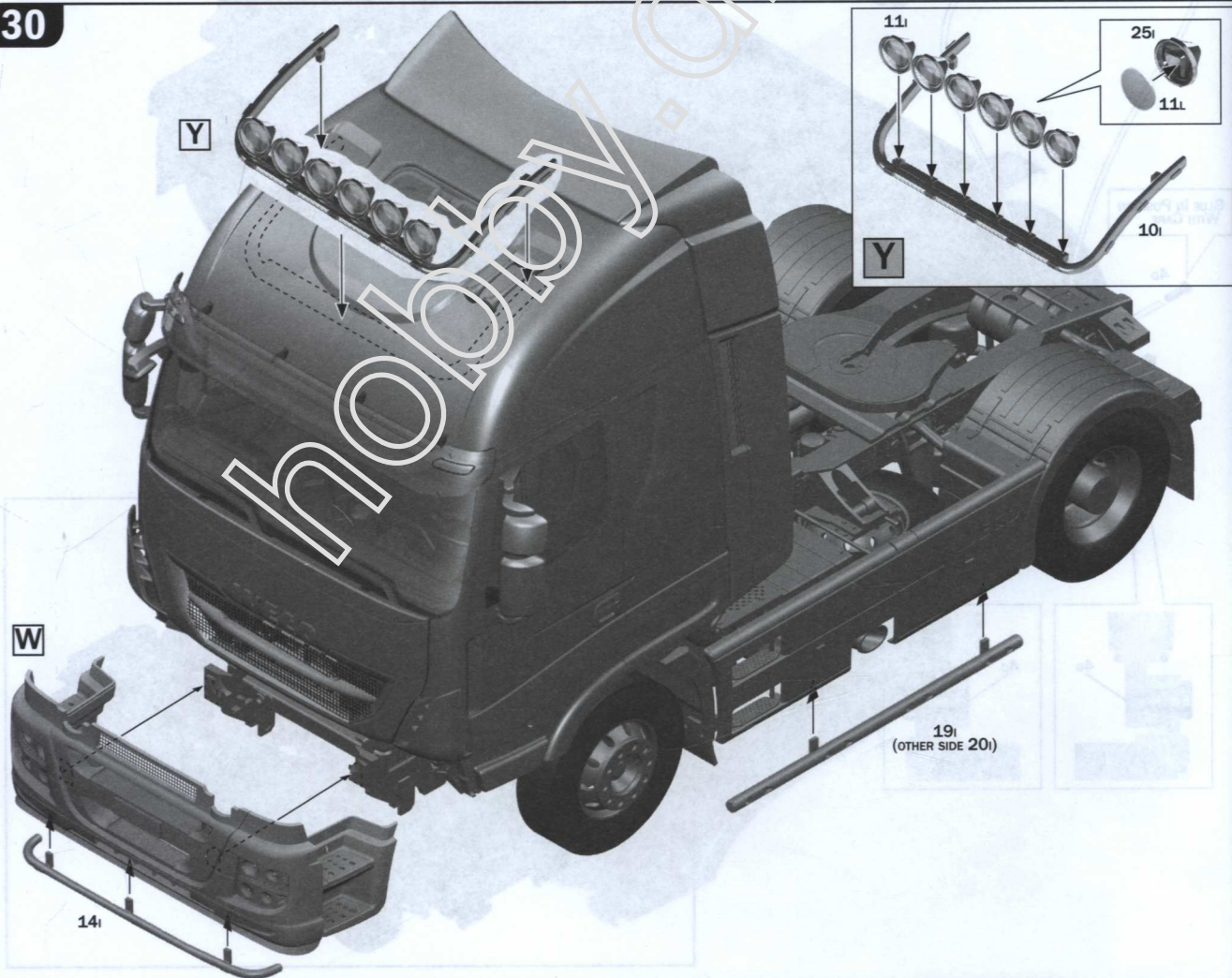

Istruzioni per l'applicazione delle decalcomanie. Ritagliare le decalcomanie occorrenti dal foglio, immergerle in un bicchiere di acqua pulita per circa 10", metterle in posizione sul modello e farle scivolare dalla carta: per una migliore aderenza comprimerle con una pezuola pulita.

Direction for applying the decals: cut the required decals out of the sheet; dip the into a glass of clean water for about 10"; position the decals on the kit, letting them slide from the paper. For a better adhesion, press them by means of a clean rag.

Påläggning av decalcer: klipp ut den decal som skall användas och doppa den i ett glas vatten under en 10". Sätt decalen på plats på modellen och låt den sakta glida av pappret. För att den skall sitta ordentligt, tryck till med en torr duk.



Anweisungen für Abziehbilder-Anbringung: Die benötigten Abziehbilder vom Blatt abscheiden, in ein Glas reines Wasser für etwa 10" eintauchen, auf das Modell legen und dann vom Papierbogen abnehmen. Um eine bessere Haftung zu erzielen, die Abziehbilder mit einem reinen Tuch andrücken.

Instruction pour l'application des décalcomanies. Couper les décalcomanies choisies et les plonger environ 10" dans un peu d'eau propre. Les placer sur le modèle en les faisant glisser de leur feuille et presser avec un morceau de chiffon pur éliminer les bulles d'air.

Istrucciones Para la aplicación de las calcomanías: cortar las requeridas, sumergirlas en un recipiente de agua limpia durante 10" colocar las calcomanías sobre el modelo, haciéndolas deslizar sobre el papel. Para una mejor adherencia, presionarlas con un trapico limpio.

Transfers: knip het benodigde deel uit, dempel et ca. 10" onder water, oud het transfer tegen het model en schuif het vanaf het papier op zijn plaats. Met een schoon doekje aandrukken.

デカール使用法 台紙から、それぞれのマークを切り取り、ぬるま湯に20秒くらいつけて、引き上げます。マークをすべらすようにして台紙からとり、指定の位置にはってください。やわらかな布でマーク上を押して気泡を取ってください。マーク面には、かわくまで手をふれないでください。

Указания по применению декалей: Отрежьте нужную вам часть декали от общего листа, поместите ее на 1/2 минуты в чистую воду, затем, выбрав необходимое место на модели, переведите туза изображение, сдвинув его с бумажной основы. Для лучшего прилипания промажьте декаль чистой тряпочкой.

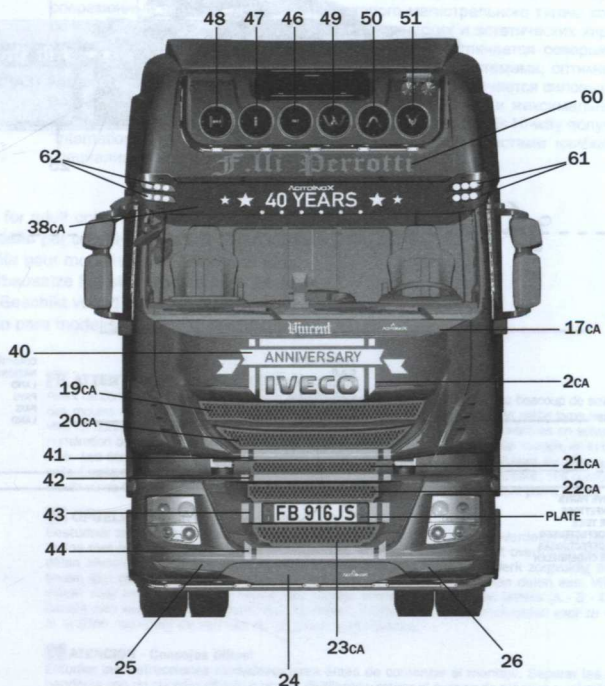
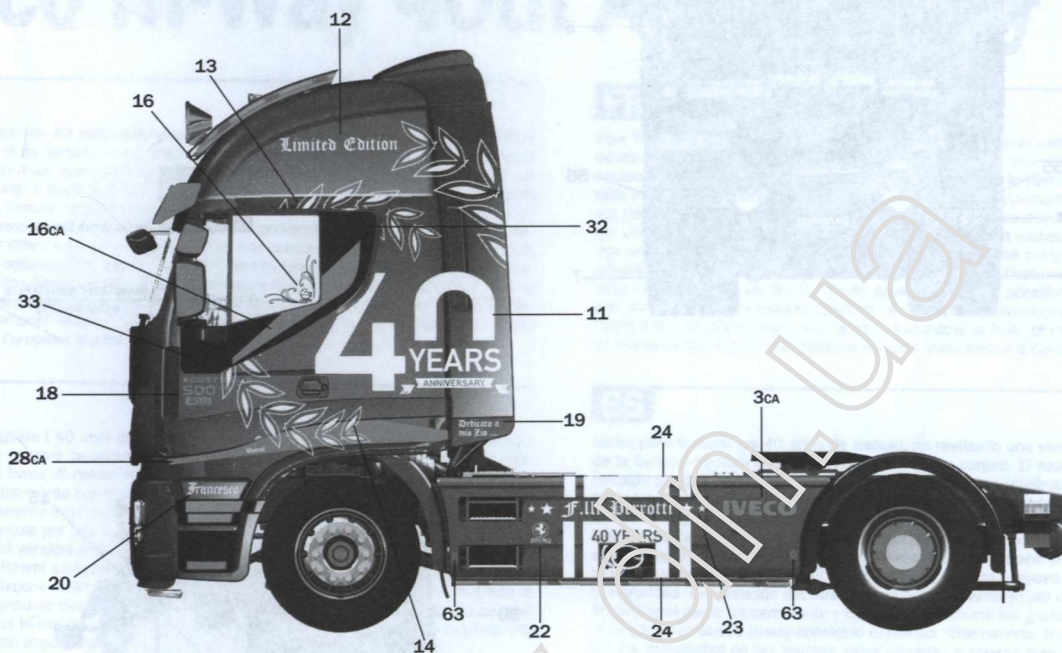

METAL GLOSS BLUE

ALTERNATIVE

GLOSS (BLUE ANGELS) BLUE
Italeri 4687AP

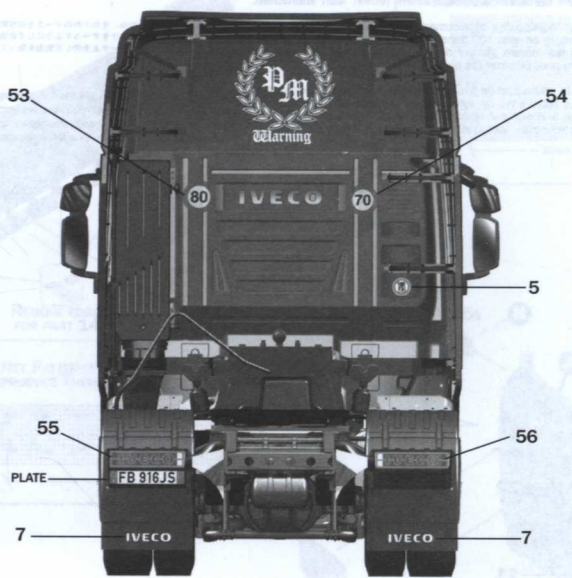

METAL GLOSS BLUE
 ALTERNATIVE **GLOSS (BLUE ANGELS) BLUE**
 Italeri 4687AP

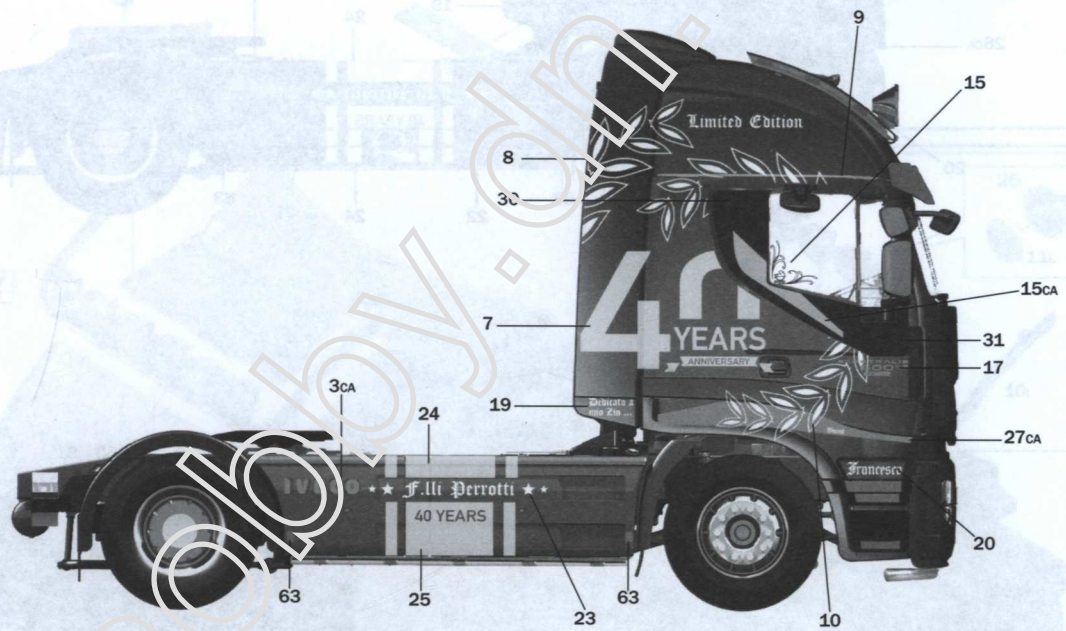

KIT No 3919 Scale 1:24 - Iveco Hi-Way 40th Anniversary

NAME
 NOME
 NAME
 NOM
 NOMBRE
 NAAM

TOWN
 CITTÀ
 STADT
 VILLE
 CIUDAD
 GEMEENTE

POSTAL CODE
 C.A.P.
 POSTALEITZAHL
 CODE POSTALE
 CODIGO POSTAL
 POSTCODE

ADDRESS
 INDIRIZZO
 ADRESSE
 ADRESSE
 DIRECCION
 ADRES

COUNTRY
 NAZIONE
 LAND
 PAYS
 PAIS
 LAND

DATE OF BIRTH
 DATA DI NASCITA
 GEBURTSDATUM
 DATE DE NAISSANCE
 NACIDO/A EL
 GEBORTE DATUM

E-MAIL

DEFECTIVE PARTS
 PARTI DIFETTOSI
 DEFEKTE TEILE
 PIÈCES DÉFECTUEUSES
 PIEZAS DEFECTUOSAS
 DEFECTE ONDERDELEN

PLACE OF PURCHASE
 ACQUISTATO PRESSO
 ORT DES KAUFES
 LIEU D'ACHAT
 LUGAR DE COMPRA
 PLAATS VAN AANKOOP

Retail Store
 Negozio
 Einzelhandel
 Detailant
 Detallista
 Detailhandel

Hyper Market
 Grande Magazzino
 Andere
 Grande Surface
 Gran Almacén
 Hypermarket

ITALERI S.p.A.
 Via Pradazzo, 6/B
 40012 - Calderara di Reno (BO) ITALY
 fax: 0039 51 726 459
 e-mail: italeri@italeri.com
 www.italeri.com