

RUSSIAN BMP-3E INFANTRY FIGHTING VEHICLE



ITEM NO: UA72034

The BMP-3 is a Soviet amphibious infantry fighting vehicle, successor to the BMP-1 and BMP-2. The abbreviation BMP stands for Boevaya Mashina Pehoty (Боевая Машина Пехоты, literally "Infantry Combat Vehicle")

The design of the BMP-3 or Obyekt 688M can be traced back to the Obyekt 685 light tank prototype with 100 mm gun 2A48-1 from 1975. This vehicle did not enter series production, but the chassis, with a new engine, was used for the next-generation infantry combat vehicle Obyekt 688 from A. Blagovoy's design bureau. The Ob.688 weapons configuration—an externally mounted 30 mm gun and twin Konkurs ATGM launcher—was rejected, instead the new 2K23 armament system was selected. The resulting BMP-3 was developed in the early 1980s and entered service with the Soviet Army officially in 1987. It was shown for the first time in public during the 1990 May Day parade and was given the NATO code IFV M1990/1.

The BMP-3 is designed and produced by the Kurganmashzavod ("Kurgan Machine Building Plant") some variants however are built by the Rubtsovsk Machine Building Plant (RMZ), for example the BRM-3M.

In May 2015, the Russian Defense Ministry signed a three-year contract to receive "hundreds" of BMP-3 vehicles to maintain its armored vehicle force until its replacement, the Kurganets-25, completes research and development. In the process of the BMP-3 serial production, the vehicle's design underwent 1,500 amendments.

The BMP-3 is one of the most heavily armed infantry combat vehicles in service, fitted with a low-velocity 2A70 100 mm rifled gun, which can fire conventional shells or 9M117 ATGMs (AT-10 Stabber). 40 100mm-rounds and 8 ATGMs are carried. A 2A72 30 mm dual feed autocannon with 500 (300 HEI and 200 APT) rounds and a rate of fire of 350 to 400 RPM, and a 7.62mm PKT machine gun with 2,000 rounds, all mounted coaxially in the turret. The main gun elevates from -5° to +60°. There are also two 7.62mm PKT bow machine guns, again with 2,000 rounds each. The BMP-3 is capable of engaging targets out to 5,000–6,000 meters with its ATGM weapon system 9K116-3 "Basnya". The minimum engagement distance, flight time and vulnerability of the launcher are typical of command-guided, rather than fire-and-forget, ATGM systems. With conventional ammunition, such as the HE-Frag shell 3OF32, the 2A70 gun has a range of 4,000 meters.

●READ BEFORE ASSEMBLY

1. When you use glue or paint, do not near flame, and use in a well-ventilated room.
2. Take extra care in handling photo etch parts in order to avoid injury
3. When you take parts off the runner frame, use modeling scissors and trim excess plastic with a cutter or a file.
4. Glue and paint are not included.
5. This product is only suitable for experienced more than 14 years old.



SUPERGLUE
强力胶



WEIGHT
配重



MAKE HOLE
钻孔



OPTION
选择



NO CEMENT
不涂胶水



DECAL
贴纸

DECAL APPLICATION

1. Cut off decal from sheet.
2. Dip the decal in tepid water 40° C for about 10 sec. and place on a clean cloth.
3. Hold the backing sheet edge and slide decal onto the model.
4. Move decal into position by wetting decal with finger.
5. Press decal gently down with a soft cloth until excess water and air bubbles are gone.

Specifications

Weight	18.7 tonnes (18.4 long tons, 20.6 short tons)
Length	7.14 m (23 ft 5 in)
Width	3.2 m (10 ft 6 in)
Height	2.4 m (7 ft 10 in)
Crew	3 (commander, gunner, driver) 7 troopers (+ 2 additional seats)
Armor	Aluminium alloy + steel, 35mm+ frontally, all around small arms fire protection
Main armament	100 mm gun/launcher 2A70 (able to fire shells or the 9M117 Bastion ATGM), 30 mm autocannon 2A72
Secondary armament	3x 7.62 mm PKT machine guns
Engine	UTD-29M diesel 500 hp (375 kW)
Suspension	Power/weight 27 hp/tonne
Operational Speed	Torsion bar
	Range 600 km (370 mi)
	72 km/h (45 mph) (road)
	45 km/h (28 mph) (off-road)
	10 km/h (6.2 mph) (water)

●装配之前仔细阅读:

1. 勿於近火处使用胶水或油漆, 并打开窗户保持空气流通。
2. 取蚀刻片时应特别注意安全, 防止利边划伤手指。
3. 从胶架中取出部件时, 应用模型专用剪, 并用界刀或小锉除去多余的胶料。
4. 请使用塑料胶水和油漆, 模型内不含。
5. 本产品不适合14岁以下没有经验的模型爱好者。

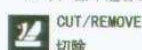

CUT/REMOVE
切除



BEND
弯曲



FILE/SAND
锉平

水贴纸的使用:

1. 从水贴纸上剪下印花。
2. 将印花放入温水中浸10秒, 然后放在干净布上。
3. 拿着印花纸板将印花移到模型上。
4. 手指蘸水将印花移到适当的位置。
5. 用软布轻压印花直至不干, 气泡消失。

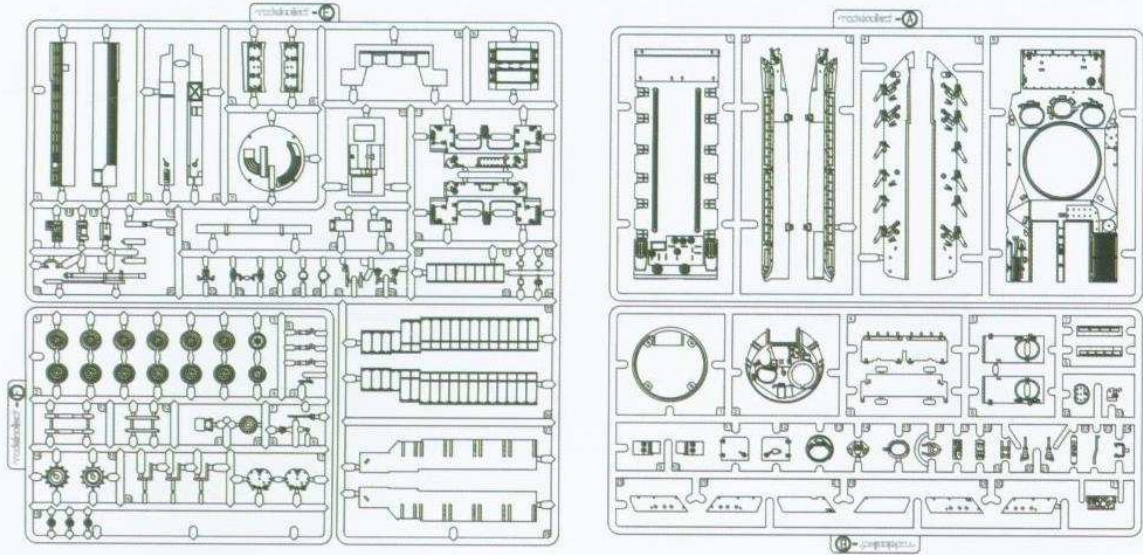

Fx2

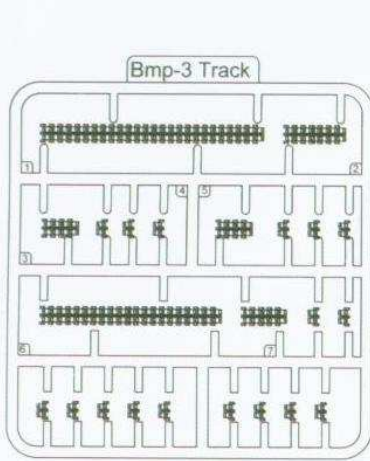

Bmp-3X 2

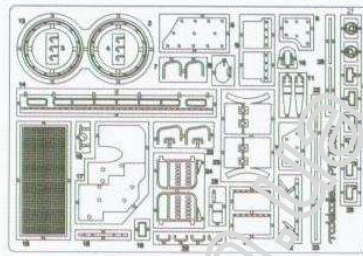

PE-72020

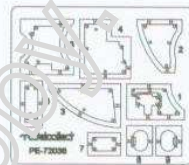

PE-72038



Decal

1 attaching turret parts 1

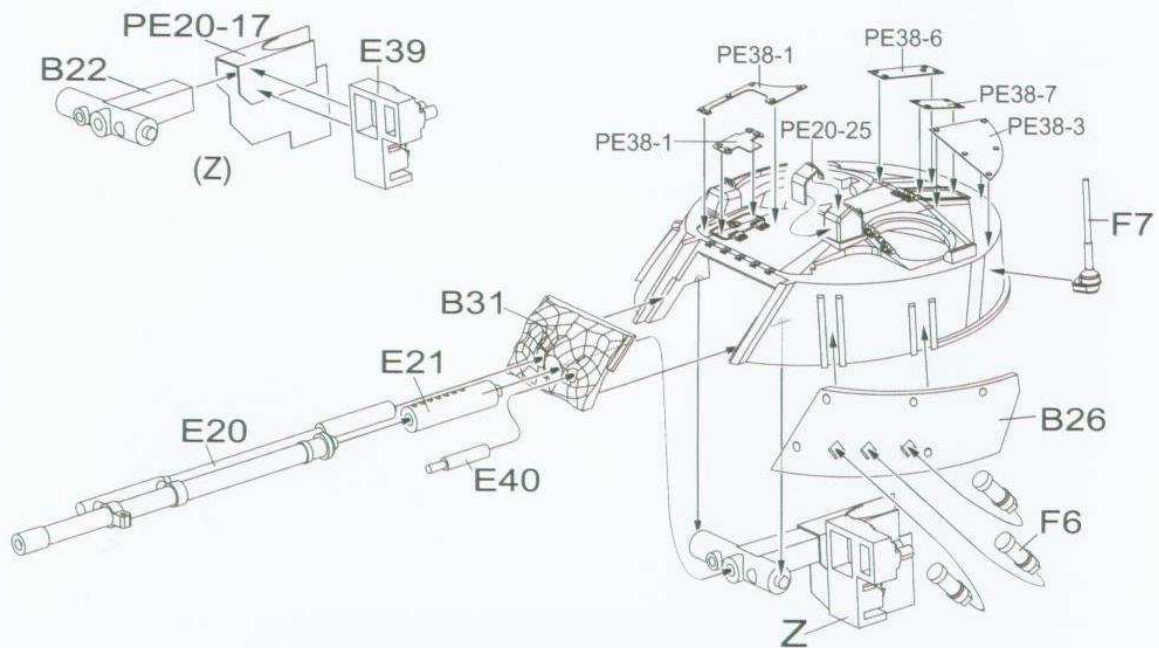

2 attaching turret parts 2

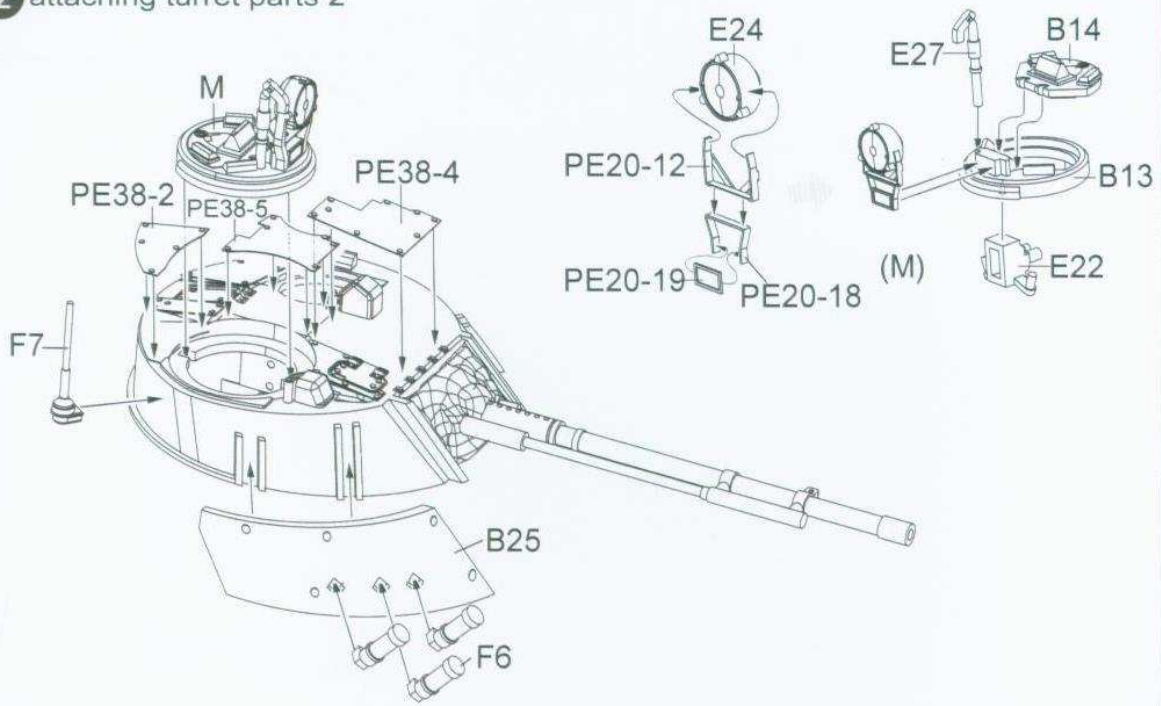

3 attaching turret parts 3

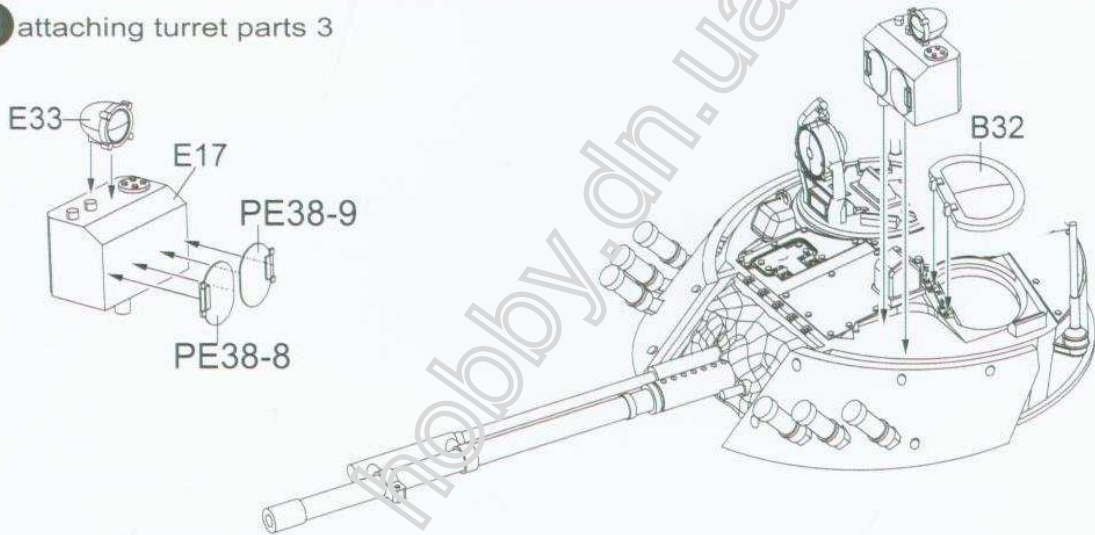

4 attaching turret internal parts 1

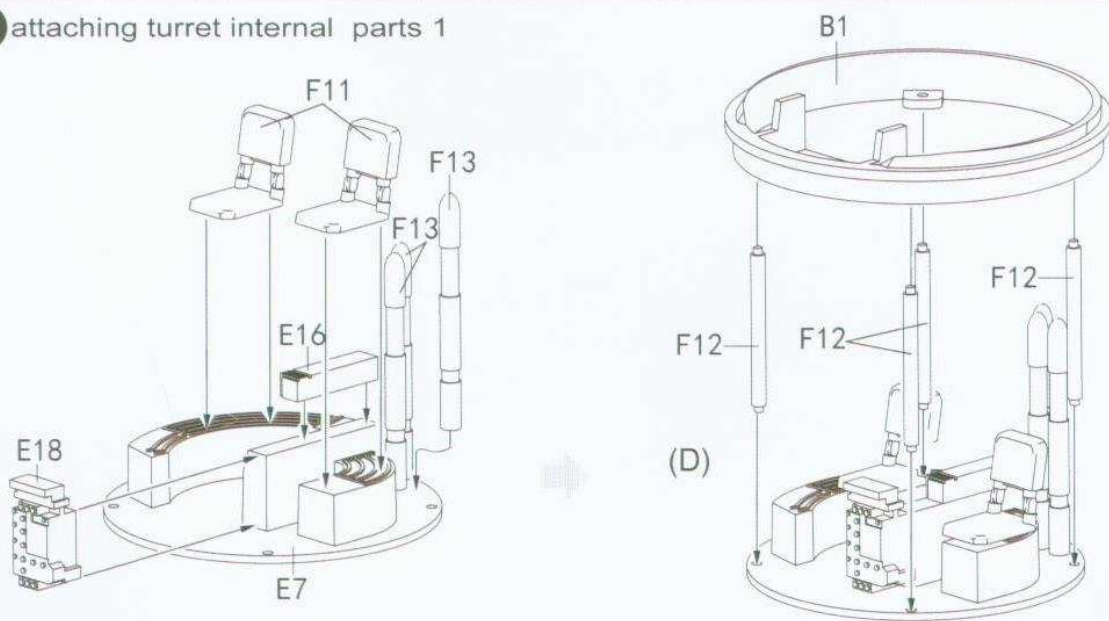

5 attaching up hull 1

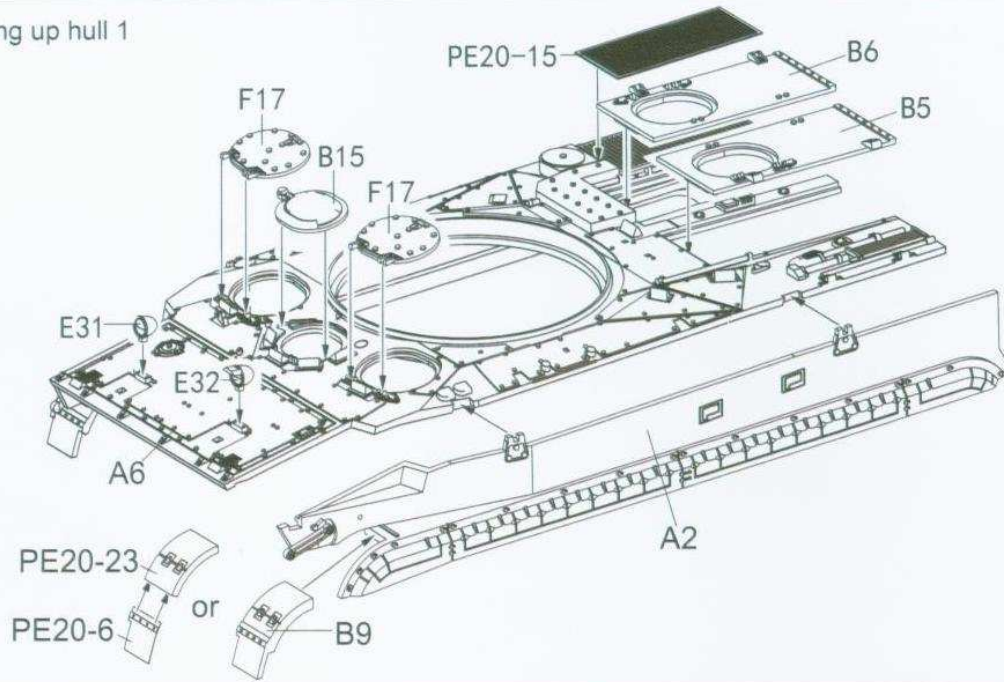

6 attaching up hull 2

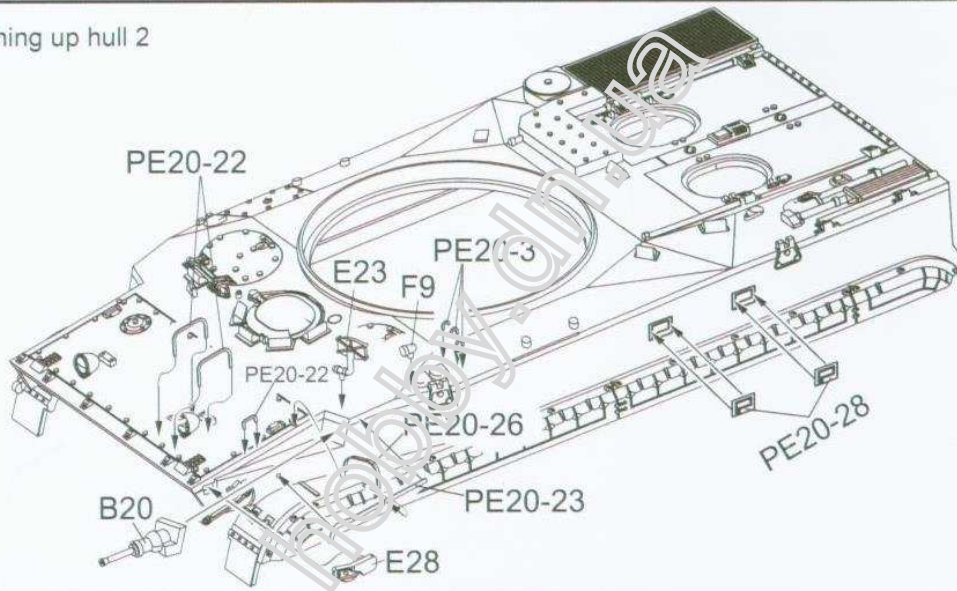

7 attaching up hull 3

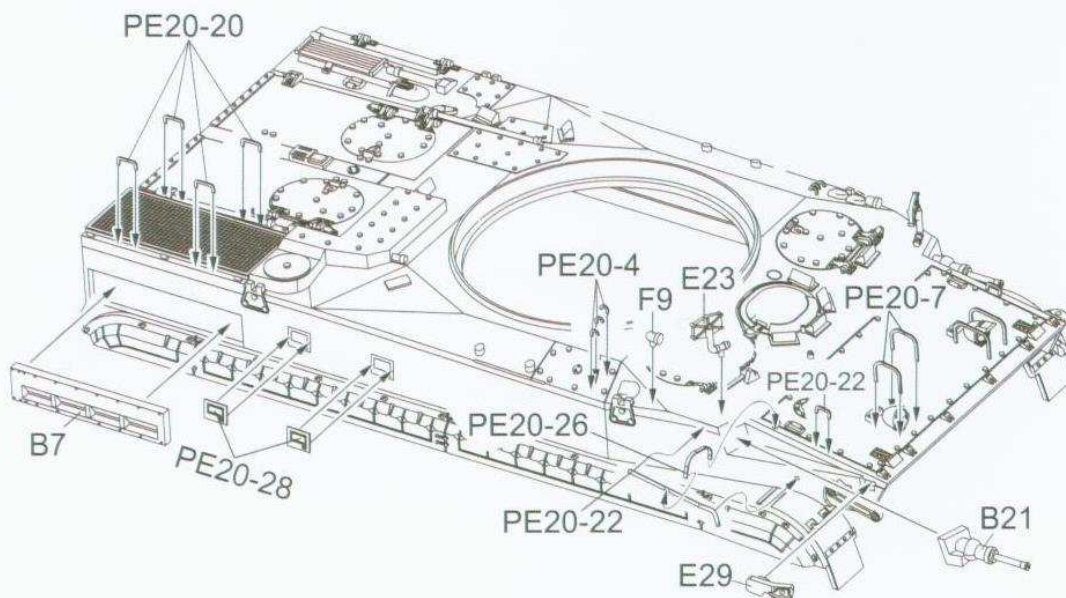

8 attaching wheels 1

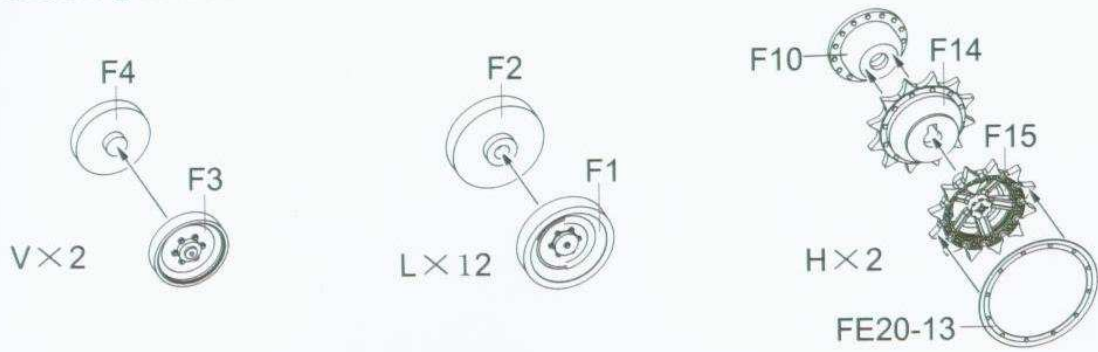

9 attaching wheels 2

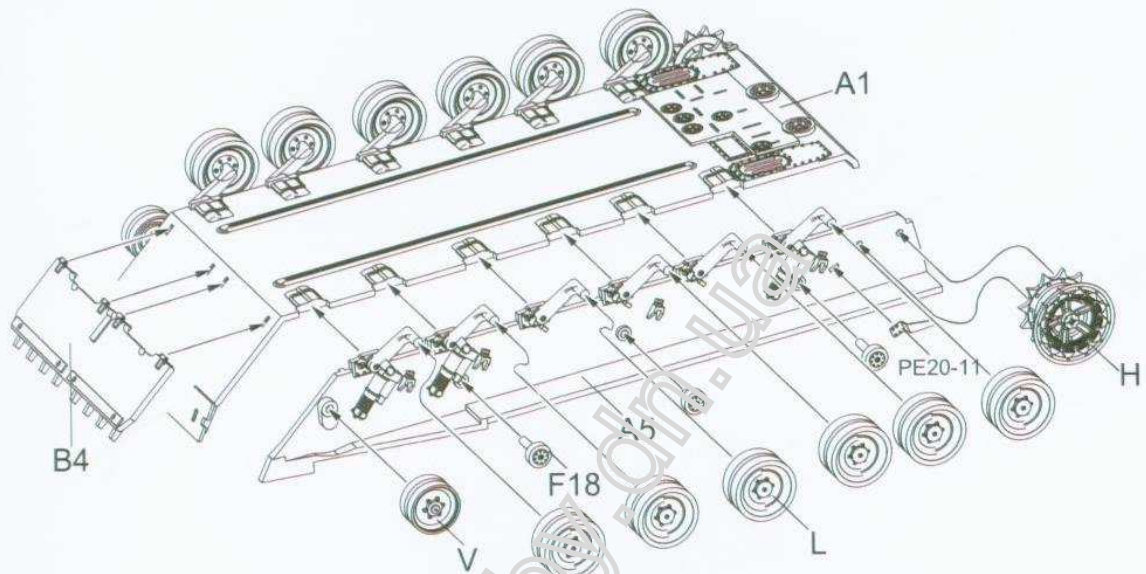

10 attaching tracks

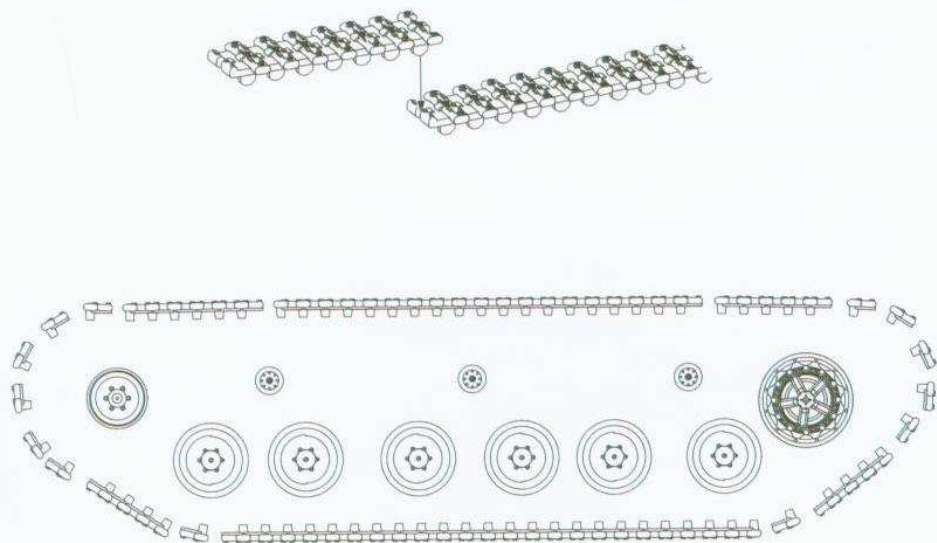

11 attaching tracks and hull internal

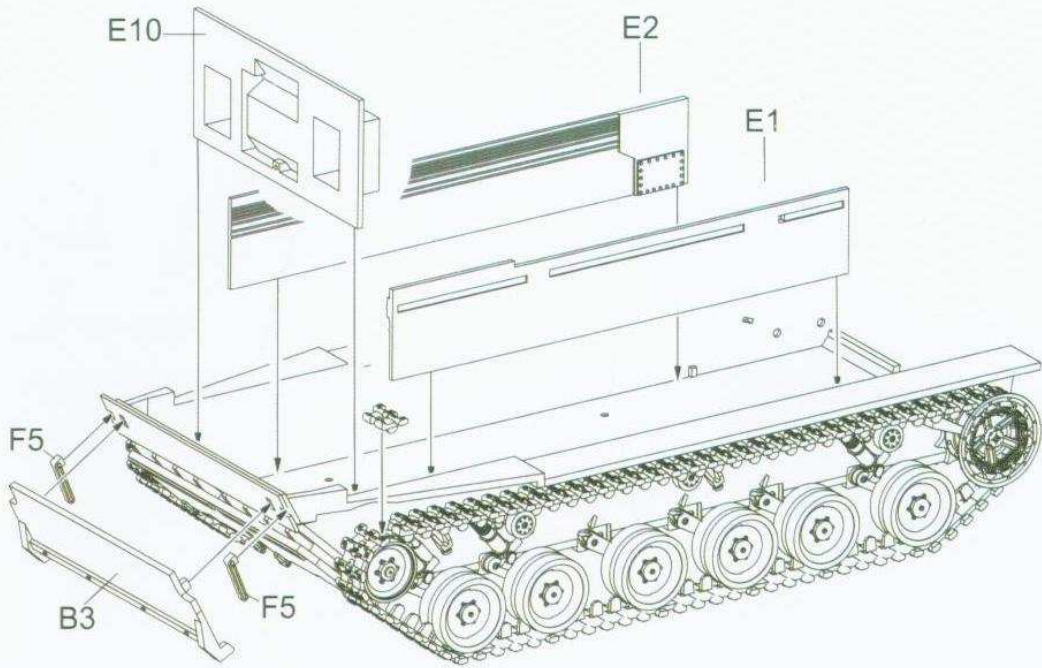

12 attaching hull internal 2

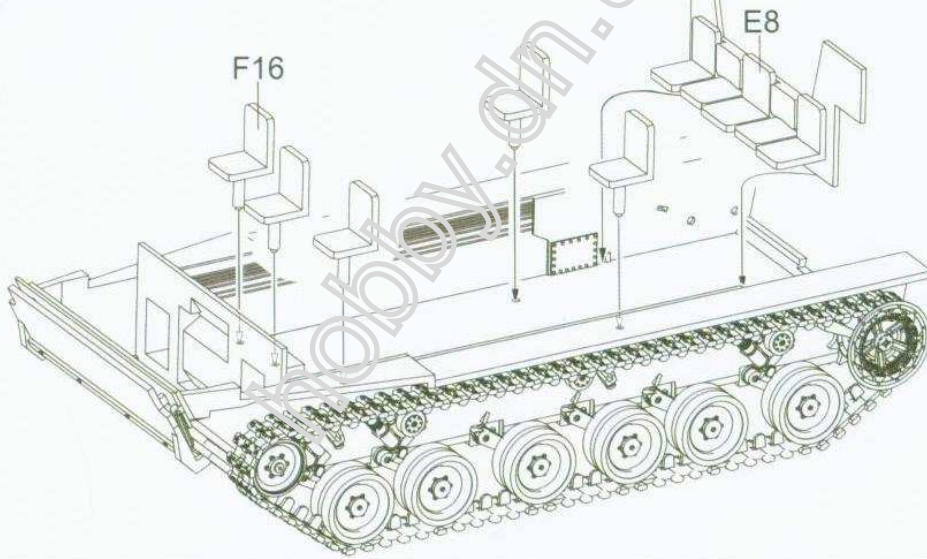

13 attaching hull internal 3

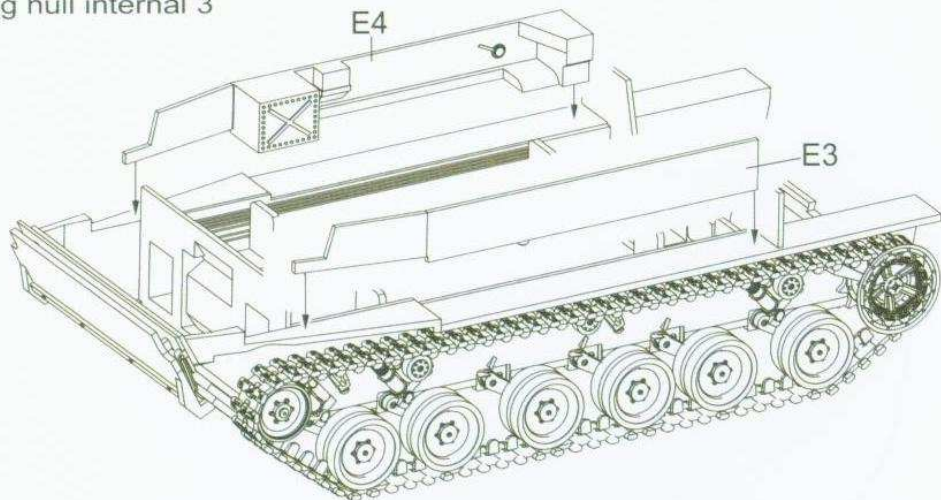

14 attaching hull internal 4 and hull

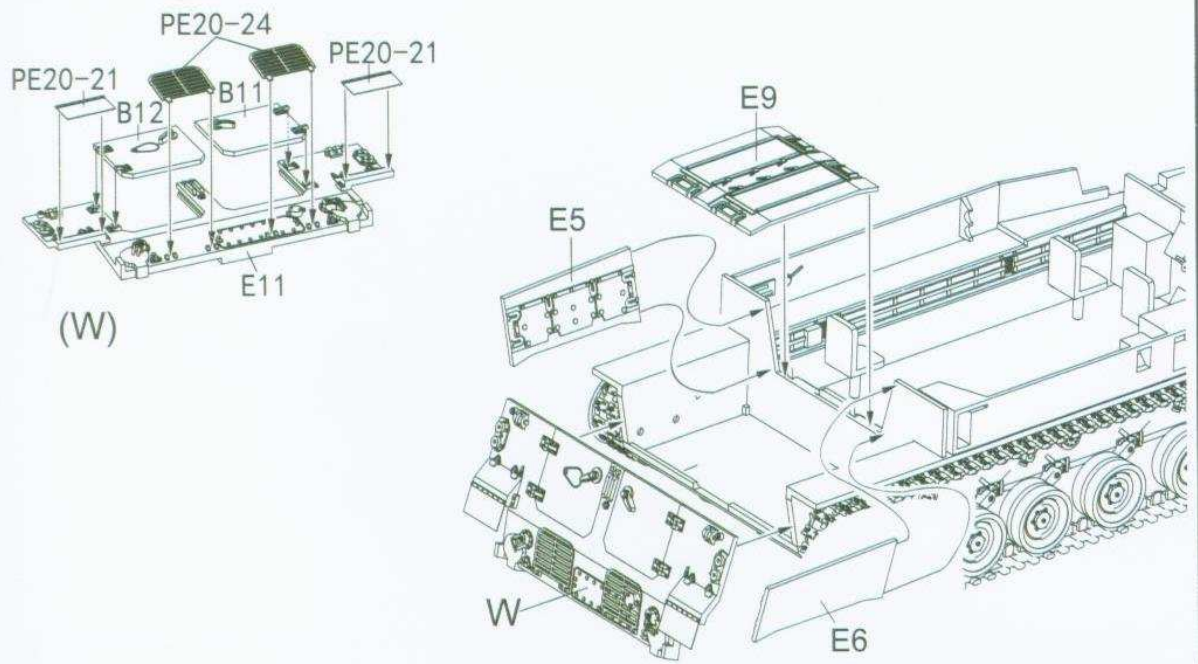

15 attaching turret

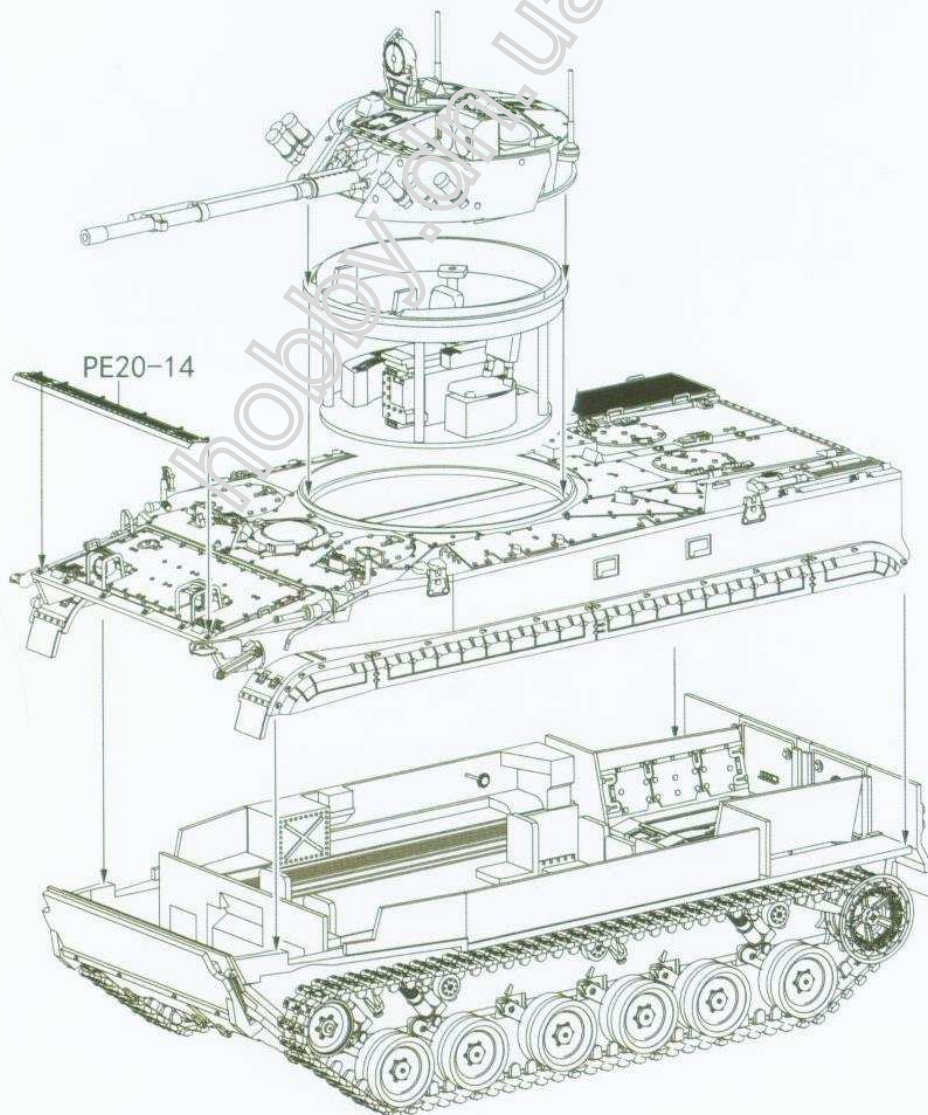

RUSSIAN BMP3E INFANTRY FIGHTING VEHICLE



A.MIG 011 RAL 7028 DUNKELGELB AUS '44 DG I A.MIG 014 RAL 8012 ROTBRAUN A.MIG 915 Dark Green A.MIG 033 Rubber & tires A.MIG 045 GUN METAL A.MIG 047 CRYSTAL SMOKE

