



07674-0379

LEVEL 5

1 2 3 4 5



VW T1 CAMPER

Beiliegenden Sicherheitstext beachten / Please note the enclosed safety advice

- Ⓢ Beiliegenden Sicherheitstext beachten und nachschlagbereit halten.
- Ⓢ Please note the enclosed safety advice and keep safe for later reference.
- Ⓢ Respecter les consignes de sécurité ci-jointes et les conserver à portée de main.
- Ⓢ Houdt u aan de bijgaande veiligheidsinstructies en hou deze steeds bij de hand.
- Ⓢ Seguire le avvertenze di sicurezza allegate e tenerle a portata di mano.
- Ⓢ Observar y siempre tener a disposición este texto de seguridad adjunto.
- Ⓢ Ter em atenção o texto de segurança anexo e guardá-lo para consulta.
- Ⓢ Overhold vedlagte sikkerhedsanvisninger og hav dem liggende i nærheden.
- Ⓢ Ha alltid vedlagt sikkerhetstekst klar til bruk.
- Ⓢ Beakta bifogad säkerhetstext och håll den i beredskap.
- Ⓢ Huomioi ja säilytä oheiset varoitukset.
- Ⓢ Соблюдать технику безопасности, сохранить инструкцию для дальнейших обращений.
- Ⓢ Przestrzegać załączonego tekstu dotyczącego bezpieczeństwa i mieć go zawsze pod ręką.
- Ⓢ Dodržujte tento příložený bezpečnostní text a mějte ho po ruce.
- Ⓢ A mellékelt biztonsági szöveget vegye figyelembe és tartsa fellapozásra készen.
- Ⓢ Respektujte příložený bezpečnostní text a uchovajte ho pre budúce použitie.
- Ⓢ Respectați textul de siguranță atașat și păstrați-l la îndemână.
- Ⓢ Спазвайте приложениа текст за безопасност и го дръжте под ръка за справки.
- Ⓢ Priložena varnostna navodila izvajajte in jih hranite na vsem dostopnem mestu.
- Ⓢ Λάβετε υπόψη σας το συνημμένο κείμενο ασφαλείας και φυλάξτε το ώστε να ανατρέχετε σε αυτό όποτε χρειάζεται.
- Ⓢ Ekteki güvenlik talimatlarını dikkate alıp, bakabileceğiniz bir şekilde muafaza ediniz.

© 2020 Revell GmbH, Henschelstr. 20-30, D-32257 Bünde.

REVELL IS THE REGISTERED TRADEMARK OF REVELL GMBH, GERMANY. www.revell.de

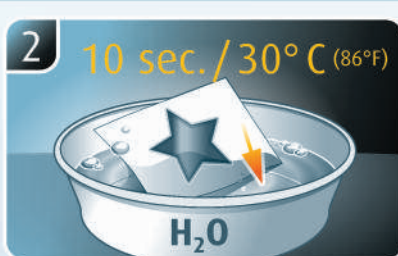
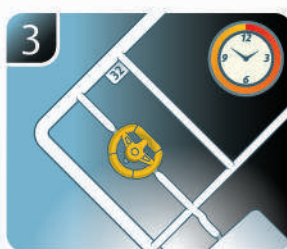
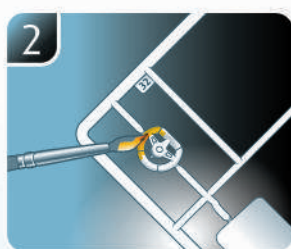
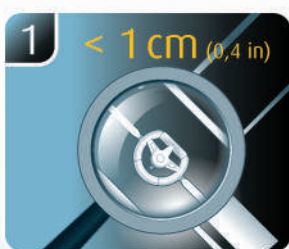
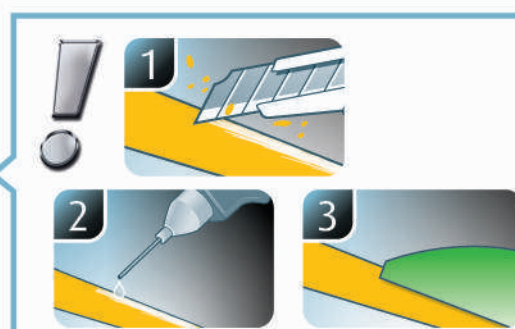
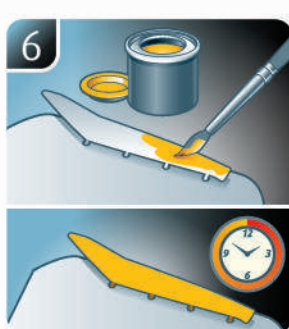
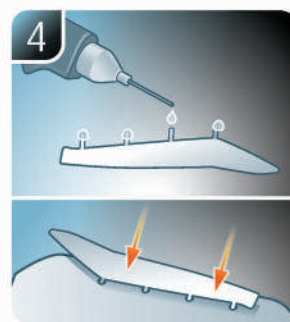
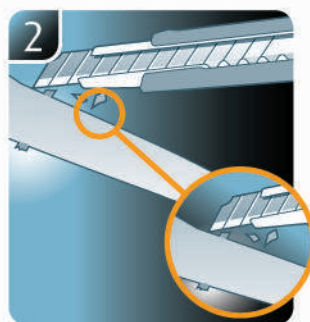
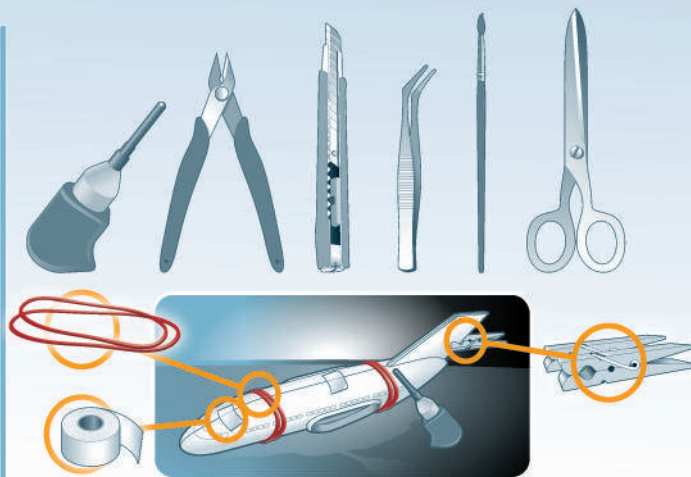

DE Weitere Tipps und Tricks.
 ES Additional tips and tricks.
 FR Conseils et astuces supplémentaires.
 NL Andere tips en trucs.
 IT Ulteriori consigli e suggerimenti.
 ES Consejos y sugerencias adicionales.
 PT Mais dicas e truques.

DE Flere tips og tricks.
 NO Flere tips og tricks.
 SE Ytterligare tips och tricks.
 FI Lisää vinkkejä ja niksejä.
 PL Dobre rady i sztuczki.
 RU Другие советы и хитрости.
 DA Dalsze wskazówki i sugestie.
 CZ Další tipy a rady.
 HU További ötletek és fogások.
 SK Ďalšie tipy a triky.
 RO Alte sfaturi și trucuri.

DE Други полезни съвети и трикове.
 SI Nadaljnji nasveti in zvijače.
 GR Πρόσθετες συμβουλές και κόλποι.
 TR Diğer öneriler ve ipuçları.

www.revell.de



- DE Kleben
- GB Glue
- FR Coller
- NL Lijmen
- IT Incollare
- ES Pegamento
- PT Colar
- DK Lim
- NO Lime
- SE Limma
- FI Liimaa
- RU Клеить
- PL Przykleić
- CZ Slepiti
- HU Ragassza rá
- SK Lepiť
- NO Lipiti
- OS Залепете
- SI Prilepite
- GR Κολλήσετε
- TR Yapıştırma



- DE Nicht kleben
- GB Don't glue
- FR Ne pas coller
- NL Niet lijmen
- IT Non incollare
- ES No pegamento
- PT Não colar
- DK Lim ikke
- NO Ikke lime
- SE Limma inte
- FI Älä liimaa
- RU Не клеить
- PL Nie przyklejać
- CZ Nelepiti
- HU Ne ragassza rá
- SK Nelepiti
- NO Nu lipiti
- OS Не лепете
- SI Ne prilepite
- GR Μη κολλήσετε
- TR Yapıştırmayın



- DE Bemalen
- GB Paint
- FR Peindre
- NL Beschilderen
- IT Colorare
- ES Pintar
- PT Pintar
- DK Mal
- NO Male
- SE Måla
- FI Maalaa
- RU Раскрасить
- PL Pomalować
- CZ Pomalovat
- HU Fesse be
- SK Natrief
- NO Vopsiti
- OS Боядисайте
- SI Robarvajte
- GR Βάψτε
- TR Boyama



- DE Wahlweise
- GB Optional
- FR Facultatif
- NL Naar keuze
- IT Facoltativamente
- ES Opcional
- PT Opcional
- DK Valgfri
- NO Valgfritt
- SE Valfri
- FI Valinnaisesti
- RU На выбор
- PL Opcjonalnie
- CZ Volitelně
- HU Választás szerint
- SK Alternativne
- NO Opjonal
- OS По избор
- SI Izbirno
- GR Προαιρετικά
- TR Opsiyonel



- DE Bauteile trocknen lassen.
- GB Allow the parts to dry.
- FR Laisser sécher les pièces.
- NL Oorderdelen laten drogen.
- IT Lasciare asciugare i componenti.
- ES Dejar secar las piezas.
- PT Deixar as peças secar.
- DK Lad delene tørre.
- NO Tørk komponenter.
- SE Låt komponenterna torka.
- FI Anna rakenneosien kuivua.
- RU Дайте деталям высохнуть.
- PL Pozostawić elementy konstrukcji do wyschnięcia.
- CZ Nechte díly uschnout.
- HU Hagyja megszáradni az alkatrészeket.
- SK Konštrukčné diely nechajte vyschnúť.
- NO Lásalj componentele să se usuce.
- OS Оставете сложените части да изсъхнат.
- SI Osušite sestavne dele.
- GR Αφήστε τα μέρη να στεγνώσουν.
- TR Yarı parçalarıni kurumaya bırakın.



- DE Zusammenbau Reihenfolge.
- GB Sequence of assembly.
- FR Ordre d'assemblage.
- NL Volgorde van montage.
- IT Sequenza di assemblaggio.
- ES Secuencia de montaje.
- PT Sequência de montagem.
- DK Samlerækkefølge.
- NO Monteringsrekkefølge.
- FI Montering ordningsføljd.
- PL Kokoamisjärjestys.
- RU Последовательность сборки.
- PL Kolejność montażu.
- CZ Pořadí složení.
- HU Összerakási sorrend.
- SK Poradie zostavenia.
- NO Ordinea asamblării.
- OS Последовательност на сглобяване.
- SI Vrstni red sestavljanja.
- GR Σειρά τοποθέτησης.
- TR Parçaları birleştirme sırası.



- DE Anzahl der Arbeitsgänge.
- GB Number of working steps.
- FR Nombre d'étapes de travail.
- NL Het aantal bouwstappen.
- IT Numero di fasi di lavoro.
- ES Número de pasos de trabajo.
- PT Número de passos de trabalho.
- DK Antal arbejds gange.
- NO Antall arbeidstrinn.
- FI Työvaiheiden määrä.
- RU Количество операций.
- PL Liczba cykli roboczych.
- CZ Počet pracovních kroků.
- HU A munkamenetek száma.
- SK Počet pracovných operácií.
- NO Numărul etapelor de lucru.
- OS Број работни стъпки.
- SI Številno delovnih postopkov.
- GR Αριθμός βημάτων εργασιών.
- TR Çalışma adımı sayısı.



- DE Gleichen Vorgang auf der gegenüberliegenden Seite wiederholen.
- GB Repeat same procedure on opposite side.
- FR Opérer de la même façon sur l'autre face.
- NL Dezelfde handeling herhalen aan de tegenoverliggende kant.
- IT Ripetere il procedimento dall'altra parte.
- ES Repetir el mismo procedimiento en el lado contrario.
- PT Repetir alguns procedimentos no lado oposto.
- DK Gentag proceduren på den modstående side.
- NO Gjenta samme forlop på motliggende side.
- SE Upprepa samma process på motsatta sidan.
- FI Toista menettely vastakkaisella puolella.
- RU Повторить такие же действия на противоположной стороне.
- PL Powtórzć te same czynności po przeciwnej stronie.
- CZ Stejný postup opakujte na protilehlé straně.
- HU Ismételje meg a műveletet az ellentétes oldalon.
- SK Rovnaký postup opakujte na protilahlej strane.
- NO Repetați același procedeu pe latura opusă.
- OS Повторете същите стъпки на срещуположната страна.
- SI Enak postopek ponovite na nasprotni strani.
- GR Επαναλάβετε την ίδια διαδικασία στην αντίθετη πλευρά.
- TR Aynı işlem adımlarını diğer tarafta da uygulayın.



- DE Loch bohren.
- GB Make a hole.
- FR Faire un trou.
- NL Maak een gat.
- IT Praticare un foro.
- ES Hacer un agujero.
- PT Fazer um furo.
- DK Lav et hul.
- NO Bor et hull.
- SE Borra hål.
- FI Poraa reikä.
- RU Просверлить отверстие.
- PL Wywiercić otwór.
- CZ Vyrvtajte otvor.
- HU Fúrjon lyukat.
- SK Vyrvtajte otvor.
- NO Faceți o gaură.
- OS Пробийте дупка.
- SI Izvrtajte izvrtino.
- GR Ανοίξτε οπή.
- TR Delik açın.



- DE Mit einem Messer abtrennen.
- GB Detach with knife.
- FR Détacher au couteau.
- NL Met een mesje afsnijden.
- IT Separare con un coltello.
- ES Separar con cuchillo.
- PT Separar com uma faca.
- DK Skær af med en kniv.
- NO Separer med kniv.
- SE Skall skiljas av med en kniv.
- FI Erotta veitsellä.
- RU Отделить ножом.
- PL Oddzielić za pomocą noża.
- CZ Oddělte nožem.
- HU Válassza le késsel.
- SK Oddelte nožom.
- NO Desprindeți cu un cuțit.
- OS Откъснете с нож.
- SI Odrežite z ustreznim rezilom.
- GR Αφαιρέστε με ένα μαχαίρι.
- TR Bir bıçak ile kesin.



- DE Abziehbild in Wasser einweichen und anbringen.
- GB Soak and apply decals.
- FR Mouiller et appliquer les décalcomanies.
- NL Transfer in water even laten weken en aanbrengen.
- IT Immergere la decalcomania nell'acqua e applicarla.
- ES Mojar y aplicar calcomanías.
- PT Amolecer o decalque em água e aplicar.
- DK Gør overførbilledet vådt og sæt det på.
- NO Myk opp avtrekkingsbildet i vann og sett på.
- SE Blötlägg dekalen i vatten och sätt på den.
- FI Pehmitä siirtokuva vedessä ja siirrä paikalleen.
- RU Опустите переводную картинку в воду и нанесите ее.
- PL Namoczyć kalkmanię w wodzie i przykleić.
- CZ Nechte obtisk odmočit ve vodě a přilepte.
- HU Merítse vízbe és helyezze fel a matricát.
- SK Otblačkový obrázok namočte do vody a priložte na plochu.
- NO Immuiați abtibildul în apă și aplicați-l.
- OS Погответе ваденката във вода и я поставете.
- SI Prelepnicu namakajte v vodi. In namestito.
- GR Μουσκεψτε σε νερό και τοποθετήστε τις χαλκομανίες.
- TR Çikartmayı suda yumuşatın ve takın.



- DE Wegfeilen
- GB File off
- FR Enlever avec une lime
- NL Wegvijlen
- IT Rimuovere con una lima
- ES Limar
- PT Remover com uma lima
- DK Fil af
- NO File av
- SE Skall filas bort
- FI Hio pois
- RU Сточить напильником
- PL Odrpłować
- CZ Odrpílovat
- HU Reszelje le
- SK Odrpílovat
- NO Piliți
- OS Изпилете
- SI Odrpilito
- GR Λιμάρετε
- TR Zımparalama



- DE Bauanleitung sorgfältig lesen.
- GB Read the assembly instructions carefully.
- FR Lisez attentivement les instructions de montage.
- NL Bouwinstructies zorgvuldig doorlezen.
- IT Leggere attentamente le istruzioni per il montaggio.
- ES Lea cuidadosamente las instrucciones de montaje.
- PT Ler atentamente as instruções de montagem.
- DK Læs byggevejledningen omhyggeligt.
- NO Les byggeanvisningen nøye.
- SE Monteringsinstruktionerna skall läsas noggrant.
- FI Lue kokoamisohje huolellisesti.
- RU Внимательно прочитайте инструкцию по сборке.
- PL Dokładnie przeczytać instrukcję montażu.
- CZ Přečtěte si pečlivě návod k obsluze.
- HU Figyelmesen olvassa el a szerelési útmutatót.
- SK Návod na montáž starostlivo prečítajte.
- NO Citiți cu atenție instrucțiunile de montare.
- SE Прочетете внимателно утъването за монтаж.
- SI Skrbno preberite navodila za sestavo.
- GR Διαβάστε προσεκτικά τις οδηγίες κατασκευής.
- TR Yarı kılavuzunu dikkatle okuyun.



- DE Ausschneiden
- GB Cut out
- FR Découper
- NL Uitsnijden
- IT Ritagliare
- ES Cortar
- PT Recortar
- DK Klip du
- NO Skjære ut
- SE Skall klippas ut
- FI Leikkaa irti
- RU Вырезать
- PL Wyciąć
- CZ Vyřiznout
- HU Vágja ki
- SK Vystrihnúť
- NO Decupați
- SE Изрязване
- SI Izrezžite
- GR Κόψτε
- TR Kesin



- DE Chromteile
- GB Chrome parts
- FR Pièces chromées
- NL Chrom onderdelen
- IT Parti cromate
- ES Piezas cromadas
- PT Peças de cromo
- DK Forkromede dele
- NO Kromdeler
- SE Kromdetaljer
- FI Kromiosat
- RU Хромированные детали
- PL Części chromowane
- CZ Chromované díly
- HU Róm alkatrészek
- SK Chromované diely
- NO Piese cromate
- SE Хромови части
- SI Kromirani deli
- GR Μέρη χρωμίου
- TR Krom parçalar



- DE Klarsichtteile
- GB Clear parts
- FR Pièces transparentes
- NL Transparente onderdelen
- IT Parti trasparenti
- ES Piezas transparentes
- PT Peças transparentes
- DK Klare dele
- NO Klare deler
- SE Genomskinliga detaljer
- FI Läpinäkyvät osat
- RU Прозрачные детали
- PL Przejrocyste części
- CZ Průhledné díly
- HU Átlátszó alkatrészek
- SK Číre diely
- NO Piese transparente
- SE Прозрачни части
- SI Prozorni deli
- GR Διάφανα μέρη
- TR Şeffaf parçalar



- DE Öffnungen mit Spachtelmasse verschließen und Oberfläche mit Schleifpapier angleichen.
- GB Close openings with putty and sand down surface.
- FR Reboucher les orifices avec du mastic et uniformiser les surfaces avec du papier à poncer.
- NL Dicht de openingen af met plamuur en maak het oppervlak glad met schuurpapier.
- IT Chiudere le aperture con del mastice e uniformare la superficie utilizzando della carta vetrata.
- ES Cerrar los extremos con masilla y lijar la superficie.
- PT Fechar as aberturas com argamassa e alisar a superfície com uma lixa.
- NO Luk åbningerne med spartelmasse, og slib overflaten i venstre side ned.
- SE Lökk åpningene med sparkelmasse og jevn ut overflaten med slippepapir.
- FR Förslut öppningarna med spackelfärg och jämna till ytan med slippapper.
- FI Sulje aukot pakkelilla ja tasoita yläpinta hiekkapaperilla.
- RU Заделать отверстия шпаклёвкой и выровнять поверхность наждачной бумагой.
- PL Zapelnąć otwory masą szpachlową i wyrównać powierzchnię, używając papieru ściernego.
- CZ Otvory uzavřete tmelem a povrch vybrusíte brusným papírem.
- HU Zárja le a nyílásokat glettelanyaggal, és a felületet simítsa le csiszolópapírral.
- SK Otvory vyplňte tmeľacom a povrch vyrovnaťte brusným papierom.
- NO Închideți orificiile cu material de spaclu și șlefuiți suprafața cu hârtie abrazivă.
- SE Китуйте отворице и изравнайте повърхността с шкурка.
- SI Odprtino zaprite z maso-lopatico in izravnajte površino z brusnim papirjem.
- GR Κλείστε τα ανοίγματα με στόκο και ξύστε την επιφάνεια με υαλοχαρτό.
- TR Boşlukları macun ile kapatın ve yüzeyi zımpara kağıdı ile düzleştirin.



- DE Zur Anbringung der Abziehbilder empfohlen.
- GB Recommended for affixing the decals.
- FR Recommandé pour l'application des décalcomanies.
- NL Aanbevolen voor het aanbrengen van de transfers.
- IT Raccomandato per l'applicazione delle decalcomanie.
- ES Recomendado para fijar bien las calcomanías.
- PT Recomendado para a fixação dos autocolantes.
- NO Anbefales til anbringelse af overføringsbillederne.
- SE Anbefales til å feste avtrekksbilder.
- RU Рекoмeндуется для нанесения переводных картинок.
- PL Zalecane do przyklejenia kalkomanii.
- CZ Doporučujeme k umístění obtiskovacích obrázků.
- HU A matrica felhelyezéséhez ajánlható.
- SK Odporúčame sa pre umiestnenie obťažkovačového obrázku.
- NO Recomandat pentru aplicarea abjibildurilor.
- SE Препоръчва се за поставяне на ваденки.
- SI Pri nameščanju nalepnice priporočamo.
- GR Συνιστάται για την τοποθέτηση των χαλκομανιών.
- TR Çikartmaların takılması için önerilir.



- DE Zur Anbringung der Chromteile empfohlen.
- GB Recommended for attaching the chrome parts.
- FR Conseillé pour le montage des pièces chromées.
- NL Aanbevolen voor monteren chromedelen.
- IT Consigliato per applicare le parti cromate.
- ES Recomendado para la fijación de piezas de cromo.
- PT Recomendado para a aplicação das peças em cromo.
- DK Anbefales til placering af kromdelene.
- NO Anbefales til montering av kromdeler.
- SE Rekommenderad för montering av kromdetaljerna.
- FI Suositellaan kromiosien siirtämiseen.
- RU Рекoмeндуется для крепления хромированных деталей.
- PL Zalecane do mocowania elementów chromowanych.
- CZ Doporučujeme k umístění chromových dílů.
- HU A róm darabok felhelyezéséhez ajánlott.
- SK Odporúčame sa pre umiestnenie chromových dielov.
- NO Recomandat pentru atașarea pieselor din crom.
- SE Препоръчва се за поставяне на хромови части.
- SI Pri nameščanju kromiranih delov priporočamo.
- GR Συνιστάται για την τοποθέτηση των εξαρτημάτων χρωμίου.
- TR Krom parçaların yapıştırılması için önerilir.



- DE Zur Anbringung der Klarteile empfohlen.
- GB Recommended to fix clear parts.
- FR Recommandé pour fixer les pièces transparentes.
- NL Aanbevolen voor het aanbrengen van transparante delen.
- IT Raccomandato per l'applicazione delle parti trasparenti.
- ES Recomendado para fijar las piezas transparentes.
- PT Recomendado para a aplicação das peças transparentes.
- DK Anbefales til anbringelse af de klare dele.
- NO Anbefales til å feste klare deler.
- SE Rekommenderad för montering av de genomskinliga detaljerna.
- FI Suositellaan läpinäkyvien osien siirtämiseen.
- RU Рекoмeндуется для крепления прозрачных деталей.
- PL Zalecane do przyklejenia przezroczystych części.
- CZ Doporučujeme k umístění průhledných dílů.
- HU Az átlátszó darabok felhelyezéséhez ajánlható.
- SK Odporúčame sa pre umiestnenie priehľadných dielov.
- NO Recomandat pentru aplicarea pieselor transparente.
- SE Препоръчва се за поставяне на прозрачни части.
- SI Pri nameščanju prozornih delov priporočamo.
- GR Συνιστάται για την τοποθέτηση των διάφανων μερών.
- TR Şeffaf parçaların takılması için önerilir.

- * DE Nicht enthalten
- GB Not included
- FR Non fourni
- NL Behoort niet tot de levering
- IT Non incluso
- ES No incluido
- PT Não incluído
- DK Medfølger ikke
- NO Ikke inkludert
- SE Ingår ej
- FI Ei sisälly
- RU Не содержится
- PL Nie wchodzi w zakres dostawy
- CZ Není obsaženo
- HU Nem tartalmazza
- NO Neobsahuje
- SI Nu este inclus
- SE Не се включва в комплекта
- SI Ni priloženo
- GR Δεν περιλαμβάνεται
- TR İçerilmiyor

Benötigte Farben / Required colours

- FR Peintures nécessaires
NL Benodigde kleuren
IT Colori necessari
ES Colores necesarios
PT Cores necessárias
NO Nødvendige farver
NO Nødvendige farger
SE Erforderliga färger
FI Tarvittavat värit
RU Необходимые краски
PL Potrzebne kolory
CZ Potřebné barvy
HU Szükséges színek
SK Požadované farby
NO Colori necesare
NO Нeобходими цветове
SI Potrebne barve
GR Απαιτούμενα χρώματα
TR Gerekl renkler

99

A

- DE Aluminium metallic
GB Aluminium metallic
FR Aluminium métallique
NL Aluminium metallic
IT Alluminio metallico
ES Aluminio metálico
PT Alumínio metálico
NO Aluminium metallisk
NO Aluminium metallisk
SE Aluminium metallisk
FI Alumiini metallinen
RU Аллюминий металлический
PL Aluminium metaliczny
CZ Hliníková metalizovaný
HU Alumínium metál
SK Hliníková metaliza
NO Aluminium metallic
NO Алюминий металлик
SI Aluminijasta kovinska
GR Αλουμίνο μεταλλικό
TR Alüminyum grisi metalik

302

B

- DE Schwarz seidenmatt
GB Black silk matt
FR Noir satiné mat
NL Zwart zijdemat
IT Nero opaco satinato
ES Negro mate satinado
PT Preto mate sedoso
NO Sort silkematt
NO Sort silkematt
SE Svart sidenmatt
FI Musta silkkimatta
RU Чёрный шелковисто-матовый
PL Czarny jedwabiscie matowy
CZ Černá jemně matný
HU Fekete, fakóselymes
SK Čierna hodvábne matný
NO Negru satinat
NO Черно коприненоматово
SI Črna svileno-mat
GR Μαύρο σατινέ
TR Siyah ipeksi mat

90

C

- DE Silber metallic
GB Silver metallic
FR Argent métallique
NL Zilver metallic
IT Argento metallico
ES Plata metálico
PT Prata metálico
NO Sølv metallisk
NO Sølv metallisk
SE Silver metallisk
FI Hopea metallinen
RU Серебрянный металлилик
PL Srebrny metaliczny
CZ Stříbrná metalizovaný
HU Ezüstmetál
SK Strieborná metaliza
NO Argintiu metalic
NO Сребро металлик
SI Srebrna kovinska
GR Ασημί μεταλλικό
TR Gümüş rengi metalik

09

D

- DE Anthrazit matt
GB Anthracite matt
FR Anthracite mat
NL Antraciet mat
IT Antracite opaco
ES Antracita mate
PT Antracite mate
NO Antrasitt matt
NO Antrasitt matt
SE Antracitgrå matt
FI Antrasiitinharmaa matta
RU Антрацит матовый
PL Antracyt matowy
CZ Antracitová šedá matný
HU Antracit, fénytelen
SK Čierna uhlová matný
NO Antracit mat
NO Антрацит матово
SI Antracit mat
GR Γκρι ανθρακί ματ
TR Antrazit mat

91

E

- DE Eisen metallic
GB Iron metallic
FR Fer métallique
NL IJzer metallic
IT Ferro metallico
ES Acero metálico
PT Aço metálico
NO Stål metallisk
NO Jern metallic
SE Stål metallic
FI Teräs metallinen
RU Сталь металлик
PL Grafít metaliczny
CZ Ocelová metalizovaný
HU Acélmetál
SK Ocelová metaliza
NO Fier metallic
NO Железо металик
SI Železna kovinska
GR Χρώμα σιδήρου μεταλλικό
TR Metalik metalik

50

F

- DE Lichtblau glänzend
GB Light blue gloss
FR Bleu clair brillant
NL Lichtblauw glanzend
IT Blu luce lucido
ES Azul claro brillante
PT Azul claro brilhante
NO Lyseblå blank
NO Lyseblå glansende
SE Lysande blå blank
FI Vaaleansininen kiiltävä
RU Светло-синий гляцевый
PL Rozświetlony niebieski błyszczący
CZ Světla modrá lesklý
HU Halványkék, fényes
SK Svetlo modrá lesklý
NO Alabastru-deschis strălucitor
NO Личностисньо гланцово
SI Svetlo-modra sijoča
GR Μπλε ανοιχτό γυαλιστερό
TR Açık mavi parlak

382

G

- DE Holzbraun seidenmatt
GB Wood brown silk matt
FR Brun bois satiné mat
NL Houtbruin zijdemat
IT Marrone legno opaco satinato
ES Marrón madera mate satinado
PT Castanho madeira mate sedoso
NO Træbrun silkematt
NO Trebrun silkematt
SE Tråbrun sidenmatt
FI Puunruskea silkkimatta
RU Древесно-коричневый шелковисто-матовый
PL Brązowy w odcieniu drewna jedwabiscie matowy
CZ Dřevěná hnědá jemně matný
HU Fa barna, fakóselymes
SK Drevená hnědá hodvábne matný
NO Maro lemnos satinat
NO Дървеснокафяво коприненоматово
SI Lesno-rjava svileno-mat
GR Καφέ ανοιχτό σατινέ
TR Ahşap rengi ipeksi mat

04

H

- DE Weiß glänzend
GB White gloss
FR Blanc brillant
NL Wit glanzend
IT Bianco lucido
ES Blanco brillante
PT Branco brilhante
NO Hvid blank
NO Hvit glansende
SE Vit blank
FI Valkoinen kiiltävä
RU Белый гляцевый
PL Biały błyszczący
CZ Bílá lesklý
HU Fehér, fényes
SK Biela lesklý
NO Alb strålucitor
NO Бяло гланцово
SI Bela sijoča
GR Λαπρο γυαλιστερό
TR Beyaz parlak

76

I

- DE Hellgrau matt
GB Light grey matt
FR Gris clair mat
NL Lichtgrijs mat
IT Grigio chiaro opaco
ES Gris claro mate
PT Cinza claro mate
NO Lysegrå mat
NO Lysegrå matt
SE Ljusgrå matt
FI Vaaleanharmaa matta
RU Светло-серый матовый
PL Jasnoszary matowy
CZ Světlá šedivá matný
HU Világosszürke, fénytelen
SK Svetlo sivá matný
NO Gri-deschis mat
NO Светлосиво матово
SI Svetlo-siva mat
GR Γκρι ανοιχτό ματ
TR Açık gri mat

371

J

- DE Hellgrau seidenmatt
GB Light grey silk matt
FR Gris clair satiné mat
NL Lichtgrijs zijdemat
IT Grigio chiaro opaco satinato
ES Gris claro mate satinado
PT Cinza claro mate sedoso
NO Lysegrå silkematt
NO Lysgrå silkematt
SE Ljusgrå sidenmatt
FI Vaaleanharmaa silkkimatta
RU Светло-серый шелковисто-матовый
PL Jasnoszary jedwabiscie matowy
CZ Světlá šedá jemně matný
HU Világosszürke, fakóselymes
SK Svetlo sivá hodvábne matný
NO Gri-deschis satinat
NO Светлосиво коприненоматово
SI Svetlo-siva svileno-mat
GR Γκρι ανοιχτό σατινέ
TR Açık gri ipeksi mat

301

K

- DE Weiß seidenmatt
GB White silk matt
FR Blanc satiné mat
NL Wit zijdemat
IT Bianco opaco satinato
ES Blanco mate satinado
PT Branco mate sedoso
NO Hvid silkematt
NO Hvit silkematt
SE Vit sidenmatt
FI Valkoinen silkkimatta
RU Белый шелковисто-матовый
PL Biały jedwabiscie matowy
CZ Bílá jemně matný
HU Fehér, fakóselymes
SK Biela hodvábne matný
NO Alb satinat
NO Бяло коприненоматово
SI Bela svileno-mat
GR Λαπρο σατινέ
TR Beyaz ipeksi mat

07

L

- DE Schwarz glänzend
GB Black gloss
FR Noir brillant
NL Zwart glanzend
IT Nero lucido
ES Negro brillante
PT Preto brilhante
NO Sort blank
NO Sort glansende
SE Svart blank
FI Musta kiiltävä
RU Чёрный гляцевый
PL Czarny błyszczący
CZ Černá lesklý
HU Fekete, fényes
SK Čierna lesklý
NO Negro-strålucitor
NO Черно гланцово
SI Črna sijoča
GR Μαύρο γυαλιστερό
TR Siyah parlak

1. 378 **M** 01 2.

DE Dunkelgrau seidenmatt
GB Dark grey silk matt
FR Gris foncé satiné mat
NL Donkergrijs zijdemat
IT Grigio scuro opaco satinato
ES Gris oscuro mate satinado
PT Cinza escuro mate sedoso
DK Mørkegrå silkematt
NO Mørk grå silkematt
SE Mörkgrå sidenmatt
FI Tummanharmaa silkkimatta
RU Темно-серый шелковисто-матовый
PL Ciemnoszary jedwabście matowy
CZ Tmavá šedá jemně matný
HU Sötétszürke, fakóselymes
SK Tmavo sivá hodvábné matný
RO Gri-închis satinat
BG Тъмносиво коприненоматово
SI Temno-siva svilenlo-mat
GR Γκρι σκούρο σατινέ
TR Koyu gri ipeksi mat

DE Farblos glänzend
GB Clear gloss
FR Incolore brillant
NL Kleurloos glanzend
IT Incolore lucido
ES Incolore brillante
PT Verniz brilhante
DK Klarlak blank
NO Klar glansende
SE Klarlack blank
FI Värítön kiiltävä
RU Бесцветный гляцевый
PL Przewroczystry blyszczący
CZ Bezbarvá lesklý
HU Színtelen, fényes
SK Priehľadný lesklý
RO Transparent strălucitor
BG Безцветно гланцово
SI Brezbarvna sijoca
GR Διαφανο υαλιστερό
TR Rensiz parlak

52 **N**

DE Blau glänzend
GB Blue gloss
FR Bleu brillant
NL Blauw glanzend
IT Blu lucido
ES Azul brillante
PT Azul brilhante
DK Blå blank
NO Blå glansende
SE Blå blank
FI Sininen kiiltävä
RU Синий гляцевый
PL Niebieski blyszczący
CZ Modrá lesklý
HU Kék, fényes
SK Modrá lesklý
RO Albastru strălucitor
BG Синьо гланцово
SI Modra sijoca
GR Μπλε υαλιστερό
TR Mavi parlak

730 **O**

DE Orange klar
GB Orange clear
FR Orange clair
NL Oranje helder
IT Arancio chiaro
ES Naranja claro
PT Laranja transparente
DK Orange klar
NO Oransje klar
SE Orange klar
FI Oranssi kirkas
RU Оранжевый прозрачный
PL Pomarańczowy przezroczysty
CZ Oranžová bezbarvý
HU Narancs, világos
SK Oranžová číry
RO Oranj curat
BG Оранжево бистро
SI Oranžna čista
GR Πορτοκαλί διάφανο
TR Turuncu canli

731 **P**

DE Rot klar
GB Red clear
FR Rouge clair
NL Rood helder
IT Rosso chiaro
ES Rojo claro
PT Vermelho transparente
DK Rødbrun klar
NO Rød klar
SE Rödbrun klar
FI Punainen kirkas
RU Красный прозрачный
PL Czerwony przezroczysty
CZ Červená bezbarvý
HU Piros, világos
SK Červená číry
RO Roșu curat
BG Червено бистро
SI Rdeča čista
GR Κόκκινο διάφανο
TR Kırmızı canli

50% 330 **Q** 382 50%

DE Feuerrot seidenmatt
GB Fiery red silk matt
FR Rouge feu satiné mat
NL Vuurood zijdemat
IT Rosso fuoco opaco satinato
ES Rojo fuego mate satinado
PT Vermelho fogo mate sedoso
DK Ildrød silkematt
NO Ildrød silkematt
SE Eldröd sidenmatt
FI Tulenpunainen silkkimatta
RU Огненно-красный шелковисто-матовый
PL Ognistoczerwony jedwabście matowy
CZ Ohnivě červená jemně matný
HU Tűzpiros, fakóselymes
SK Ohnivá červená hodvábné matný
RO Roșu aprins satinat
BG Огненочервено коприненоматово
SI Ognjeno-rdeča svilenlo-mat
GR Κόκκινο φωτιάς σατινέ
TR Alev kırmizisi ipeksi mat

DE Holzbraun seidenmatt
GB Wood brown silk matt
FR Brun bois satiné mat
NL Houtbruin zijdemat
IT Marrone legno opaco satinato
ES Marrón madera mate satinado
PT Castanho madeira mate sedoso
DK Træbrun silkematt
NO Trebrun silkematt
SE Träbrun sidenmatt
FI Puunruskea silkkimatta
RU Древесно-коричневый шелковисто-матовый
PL Brązowy w odcieniu drewna jedwabście matowy
CZ Dřevěná hnědá jemně matný
HU Fa barna, fakóselymes
SK Drevená hnědá hodvábné matný
RO Maro lemnos satinat
BG Дървеснокафяво коприненоматово
SI Lesno-rjava svilenlo-mat
GR Καφέ αροσιχτό σατινέ
TR Ahşap rengi ipeksi mat

50% 90 **R** 94 50%

DE Silber metallic
GB Silver metallic
FR Argent métallique
NL Zilver metallic
IT Argento metallico
ES Plata metálico
PT Prata metálico
DK Sølv metallic
NO Sølv metallic
SE Silver metallic
FI Hopea metallinen
RU Серебряный металлик
PL Srebrny metaliczny
CZ Stříbrná metalizový
HU Ezüstmetál
SK Strieborná metaliza
RO Argintiu metalic
BG Сребро металик
SI Srebrna kovinska
GR Ασημί μεταλλικό
TR Gümüş rengi metalik

DE Gold metallic
GB Gold metallic
FR Or métallique
NL Goud metallic
IT Oro metallico
ES Oro metálico
PT Ouro metálico
DK Guld metallisk
NO Gull metallic
SE Guld metallic
FI Kultta metallinen
RU Золото металлик
PL Złoty metaliczny
CZ Zlatá metalizový
HU Aranymetál
SK Zlatá metaliza
RO Auriiu metalic
BG Злато металик
SI Zlata kovinska
GR Χρυσοαφι μεταλλικό
TR Altın rengi metalik

374 **S**

DE Grau seidenmatt
GB Grey silk matt
FR Gris satiné mat
NL Grijs zijdemat
IT Grigio opaco satinato
ES Gris mate satinado
PT Cinzento mate sedoso
DK Grå silkematt
NO Grå silkematt
SE Grå sidenmatt
FI Harmaa silkkimatta
RU Серый шелковисто-матовый
PL Szary jedwabście matowy
CZ Šedá jemně matný
HU Szürke, fakóselymes
SK Sivá hodvábné matný
RO Gri satinat
BG Сиво коприненоматово
SI Siva svilenlo-mat
GR Γκρι σατινέ
TR Gri ipeksi mat

378 **T**

DE Dunkelgrau seidenmatt
GB Dark grey silk matt
FR Gris foncé satiné mat
NL Donkergrijs zijdemat
IT Grigio scuro opaco satinato
ES Gris oscuro mate satinado
PT Cinza escuro mate sedoso
DK Mørkegrå silkematt
NO Mørk grå silkematt
SE Mörkgrå sidenmatt
FI Tummanharmaa silkkimatta
RU Темно-серый шелковисто-матовый
PL Ciemnoszary jedwabście matowy
CZ Tmavá šedá jemně matný
HU Sötétszürke, fakóselymes
SK Tmavo sivá hodvábné matný
RO Gri-închis satinat
BG Тъмносиво коприненоматово
SI Temno-siva svilenlo-mat
GR Γκρι σκούρο σατινέ
TR Koyu gri ipeksi mat

330 **U**

DE Feuerrot seidenmatt
GB Fiery red silk matt
FR Rouge feu satiné mat
NL Vuurood zijdemat
IT Rosso fuoco opaco satinato
ES Rojo fuego mate satinado
PT Vermelho fogo mate sedoso
DK Ildrød silkematt
NO Ildrød silkematt
SE Eldröd sidenmatt
FI Tulenpunainen silkkimatta
RU Огненно-красный шелковисто-матовый
PL Ognistoczerwony jedwabście matowy
CZ Ohnivě červená jemně matný
HU Tűzpiros, fakóselymes
SK Ohnivá červená hodvábné matný
RO Roșu aprins satinat
BG Огненочервено коприненоматово
SI Ognjeno-rdeča svilenlo-mat
GR Κόκκινο φωτιάς σατινέ
TR Alev kırmizisi ipeksi mat

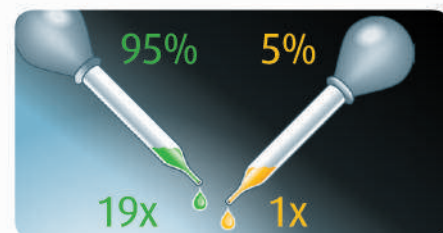

DE Beispiel: mischen
GB Example: mixing
FR Exemple: mélanger
NL Voorbeeld: mengen
IT Esempio: mescolare
ES Ejemplo: mezcla
PT Exemplo: misturar
DK Eksempel: blanding
NO Eksempel: blanda
SE Exempel: blanda
FI Esimerkki: sekoittaminen

RU Пример: смешивание
PL Przykład: mieszać
CZ Příklad: míchat
HU Példa: keverés
SK Příklad: miešanie
RO Exemplu: amestecare
BG Пример: смесване
SI Primer: mešanje
GR Παράδειγμα: ανάμειξη
TR Örnek: karıştırma

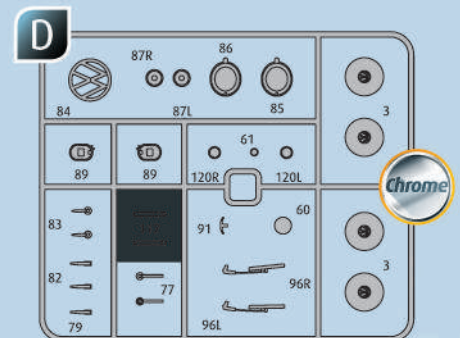
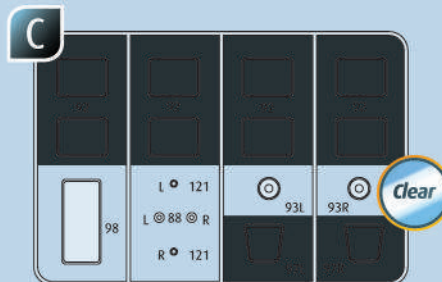
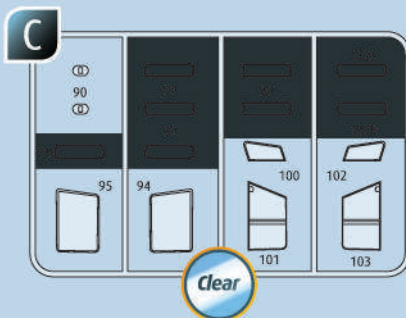
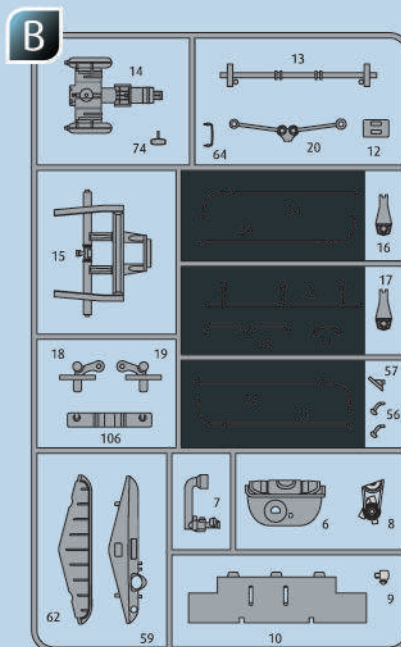
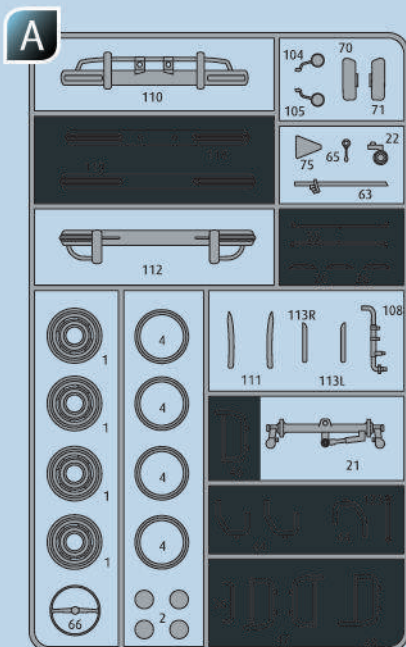

- ⊖ Nicht benötigte Teile
- ⊖ Parts not used.
- ⊖ Pièces non utilisées.
- ⊖ Niet benodigde onderdelen.
- ⊖ Parti non necessarie.
- ⊖ Piezas no utilizadas.
- ⊖ Peças não utilizadas.

- ⊖ Dele der ikke skal bruges.
- ⊖ Deler som ikke er nødvendige.
- ⊖ Ej nödvändiga delar.
- ⊖ Tarpeetomat osat.
- ⊖ Неиспользуемые детали.
- ⊖ Niepotrzebne części.
- ⊖ Nepotřebné díly.

- ⊖ Szükségtelen alkatrészek.
- ⊖ Nepotrebne diely.
- ⊖ Piese care nu sunt necesare.
- ⊖ Ненужни детали.
- ⊖ Nepotrebni deli.
- ⊖ Μη χρησιμοποιούμενα μέρη.
- ⊖ Gerekti olmayan parçalar.

Ersatzteile benötigt?

Kein Problem. Einfach den Revell-Service mit Angabe von Artikel- und Teilenummer kontaktieren. Entweder unter service@revell.de oder Revell GmbH, Abteilung X, Henschelstr. 20-30, 32257 Bünde.*

*Wir bitten um Verständnis, dass eine Gewährleistung nur bei aktuellen Artikeln, die im Zeitraum der letzten 24 Monate erworben wurden, übernommen werden kann. Mit der Ersatzteil-Bestellung können Kosten z.B. für Verpackung und Versand entstehen. Ob diese Kosten anfallen wird im Vorfeld schriftlich durch unseren Service mitgeteilt. Das Angebot kann dann angenommen oder abgelehnt werden. Unfrei eingesandte Ersatzteil-Bestellungen werden von uns nicht angenommen! Dieser Direktservice gilt für die Länder Deutschland, Benelux, Österreich, Frankreich, Großbritannien. Ersatzteil-Bestellungen aus den übrigen Ländern werden über die jeweiligen Distributeure abgewickelt. Bitte kontaktieren Sie Ihren Händler.

Besoin de pièces de rechange ?

Il vous suffit de contacter le service Revell et d'indiquer la référence de l'article et de la pièce. Soit en écrivant par mail à france@revell.de (uniquement pour la France) ou par courrier à Revell GmbH, Département X, Henschelstr. 20-30, D-32257 Bünde.*

*La garantie s'applique pour les articles présents au catalogue et achetés au cours des 24 derniers mois. Merci de votre compréhension. La commande de pièces de rechange peut donner lieu à des frais supplémentaires, par ex. pour l'emballage et le port. Notre service client vous en informera au préalable par écrit. Vous pourrez accepter ou refuser le devis. Nous n'acceptons pas les commandes de pièces de rechange envoyées sans affranchissement ! Ce service direct est valable pour les pays suivants : Allemagne, Benelux, Autriche, France, Grande-Bretagne. Les commandes de pièces en provenance d'autres pays sont traitées par les distributeurs correspondants. Veuillez contacter votre revendeur.

Need spare parts?

No problem. Contact Revell Service with the item number and part numbers you need: service@revell.de or Revell GmbH, Unit 10, Old Airfield Industrial Estate, Cheddington Lane, Tring, Herts, HP23 4QR, Great Britain.*

*We request your understanding that a warranty can only be accepted for current articles which have been purchased in the last 24 months. Orders for spare parts may also be subject to costs for packaging and shipping. You will be notified in advance by our Service department if such costs are incurred. The offer can then be accepted or rejected. We will not be able to process any postal requests unless correct postage has been applied to mailing! This direct service applies to the countries: Germany, Benelux, Austria, France, and the United Kingdom. Spare part orders from other countries are processed by the local distributors. Please contact your dealer.

Hebt u reserveonderdelen nodig?

Geen probleem! Neem eenvoudig contact op met de klantenservice van Revell en geef ons het artikel- en onderdeelnummer door. U kunt ons bereiken op service@revell.de of per post: Revell GmbH, Afdeling X, Henschelstr. 20-30, D-32257 Bünde.*

*Wij vragen uw begrip voor de omstandigheid, dat er alleen garantie kan worden geboden voor actuele artikelen, die in de afgelopen 24 maanden zijn gekocht. Met het bestellen van reserveonderdelen kunnen kosten gemoeid zijn, bijv. voor verpakking en verzending. U wordt vooraf schriftelijk door onze klantenservice op de hoogte gesteld als er kosten zouden ontstaan. Het aanbod kan dan worden aangenomen of afgewezen. Wij nemen geen ongefrankeerde bestellingen van reserveonderdelen aan! Deze rechtstreekse service wordt verleend in de landen Duitsland, de Benelux, Oostenrijk, Frankrijk en Groot-Brittannië. Bestellingen van reserveonderdelen in de overige landen worden afgewikkeld via de betreffende distributeurs. Neem hiervoor contact op met uw verkoper.

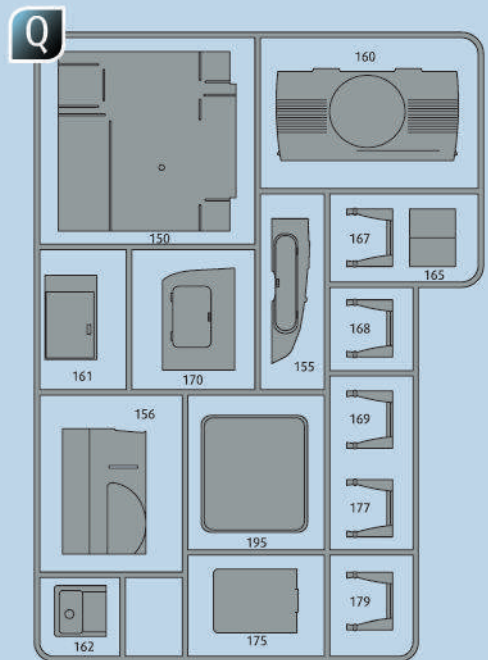
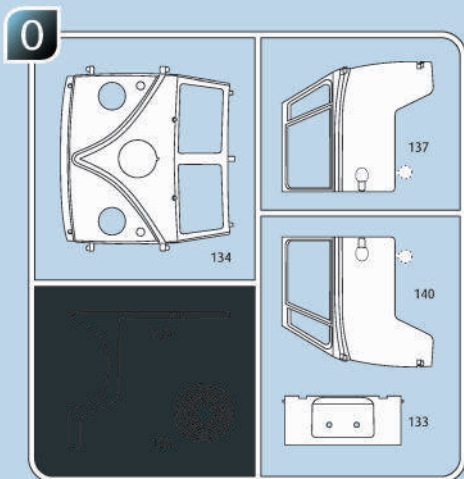
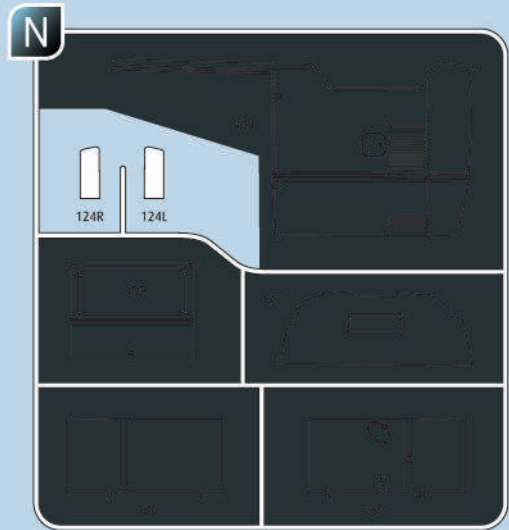
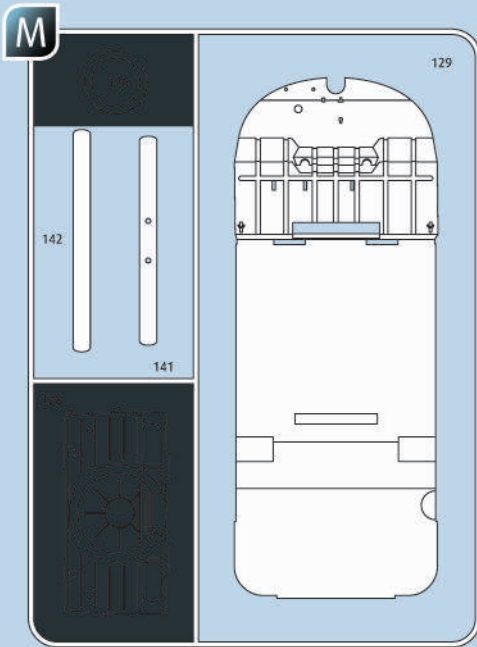
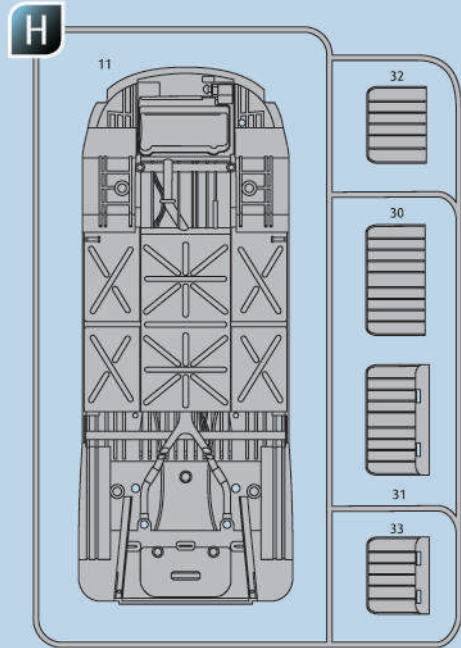
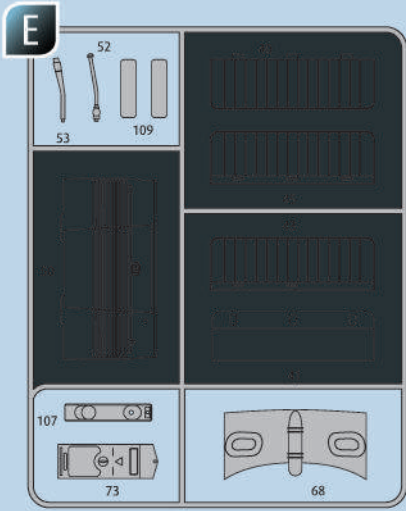

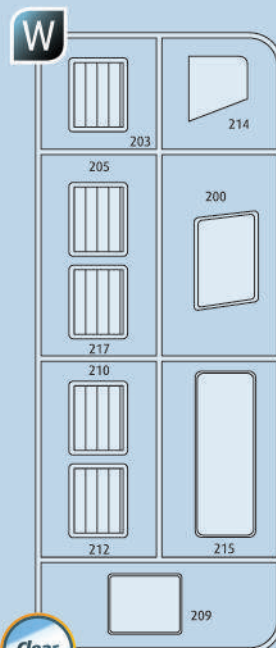
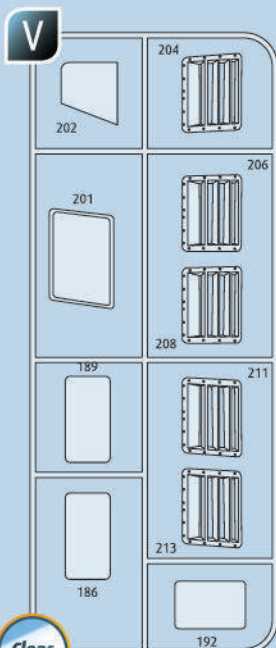
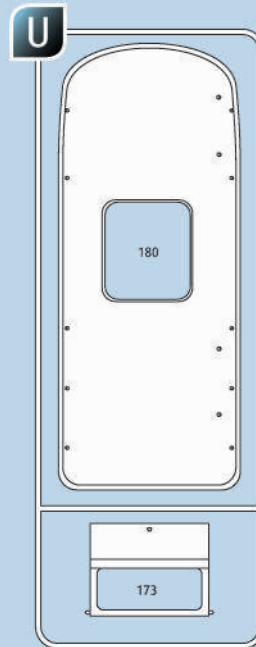
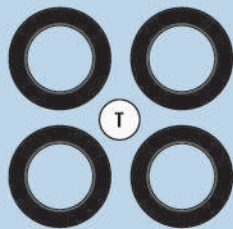
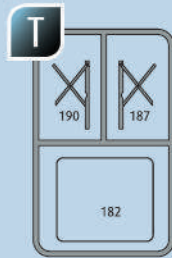
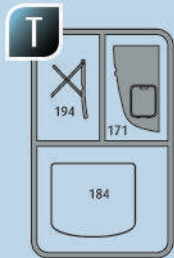
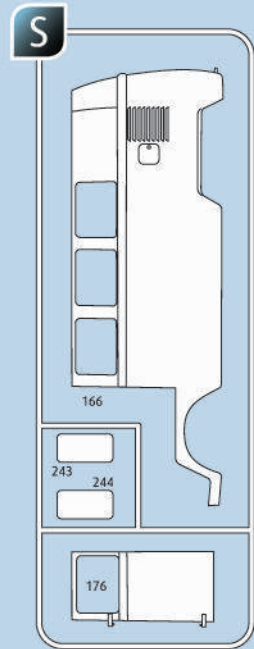
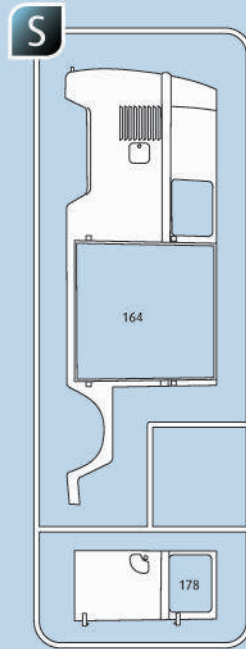
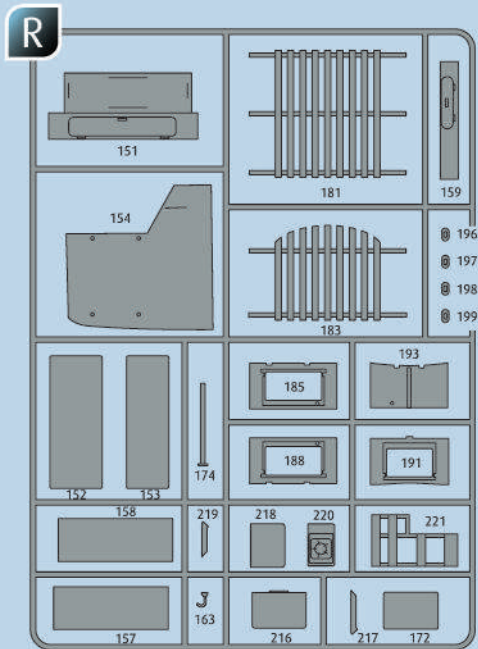

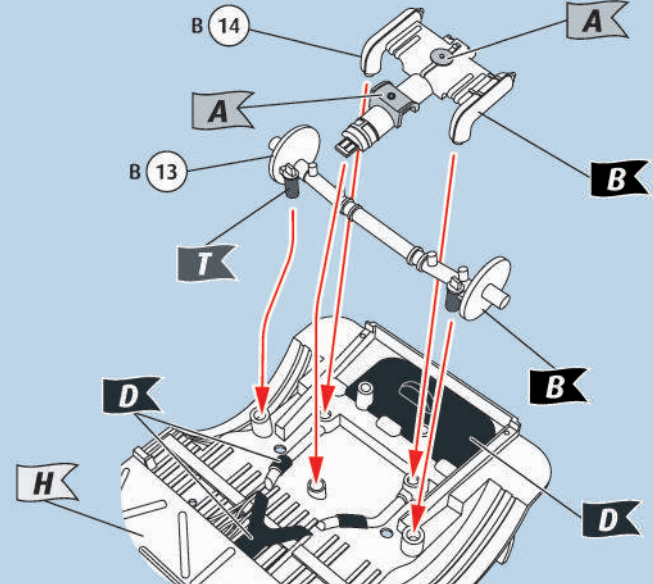
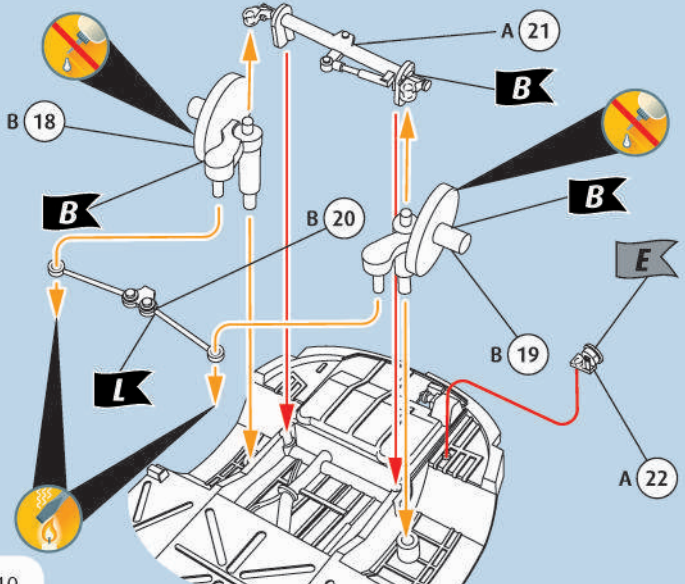
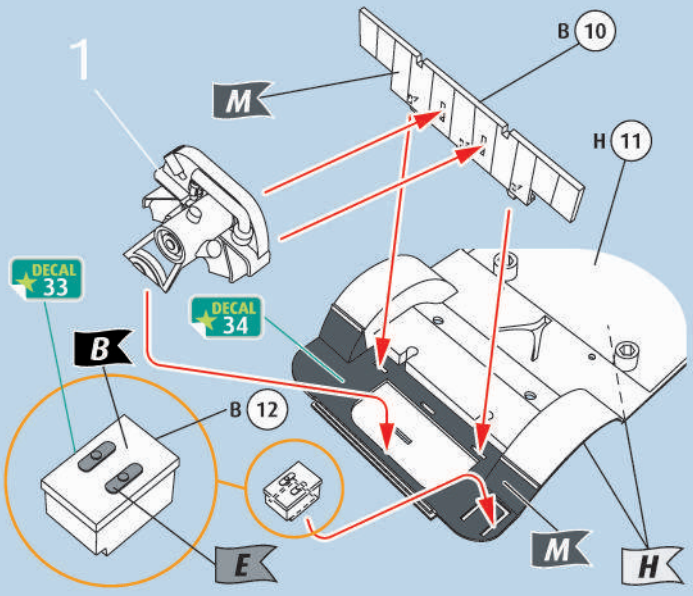
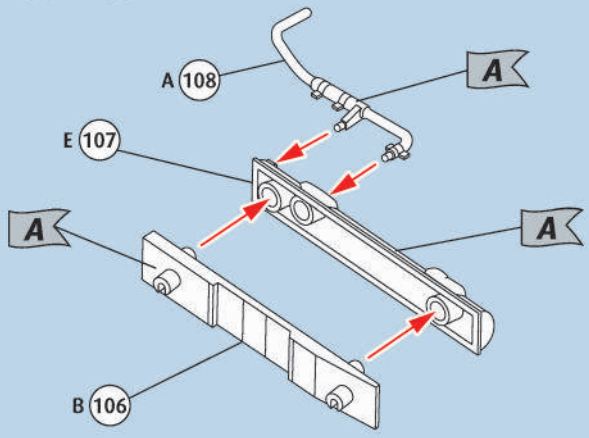
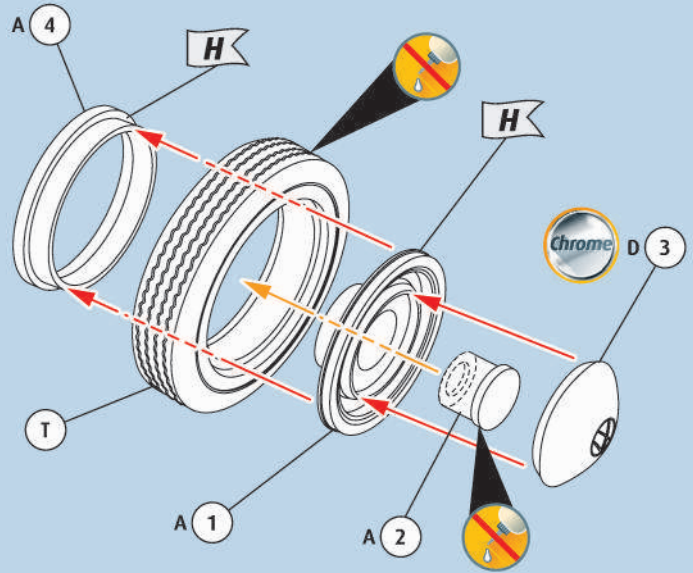
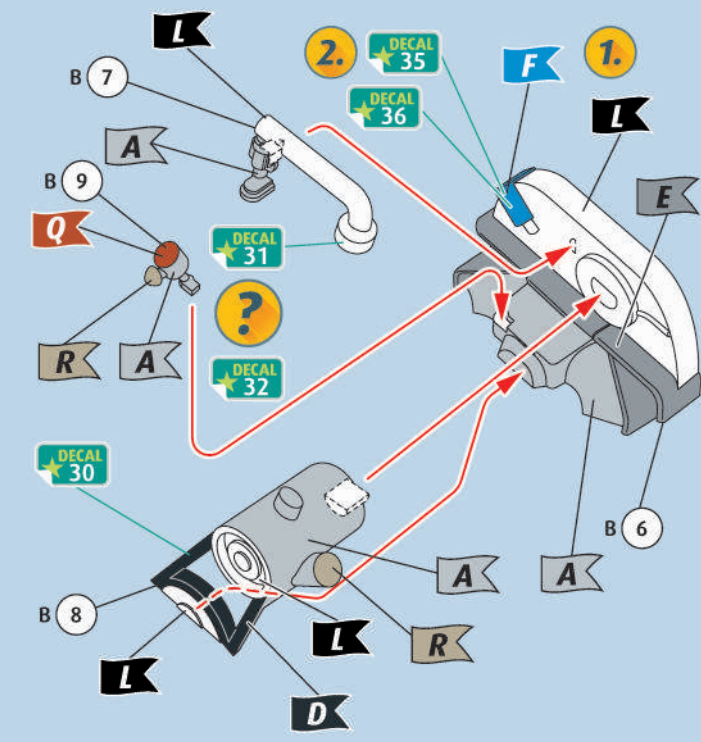

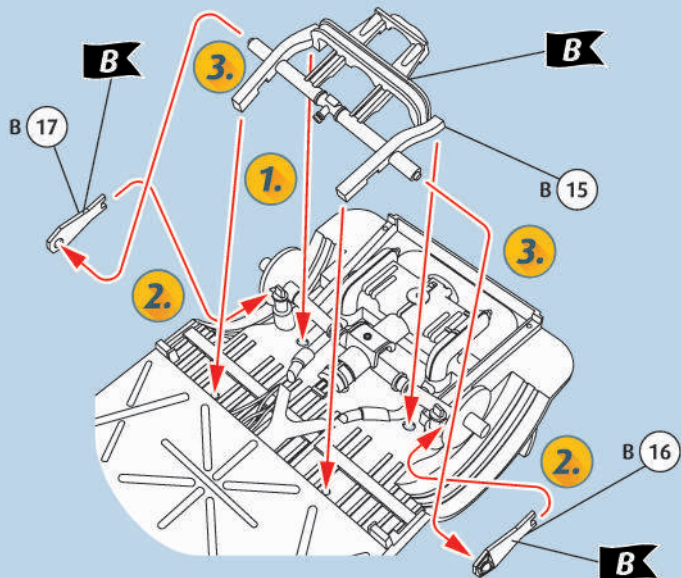
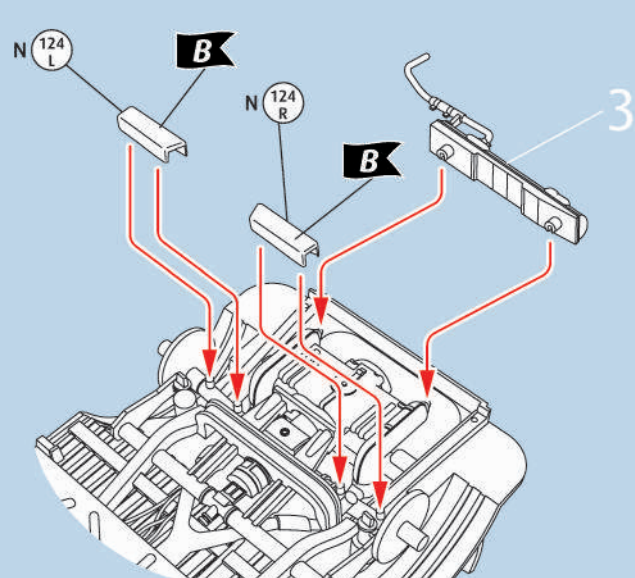
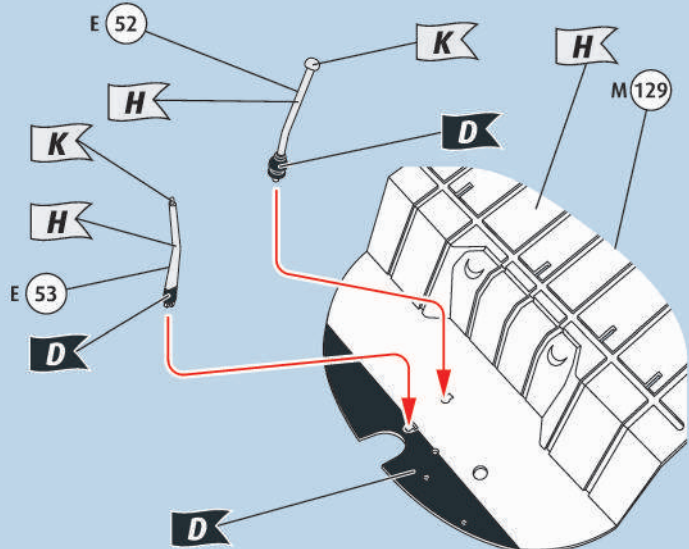
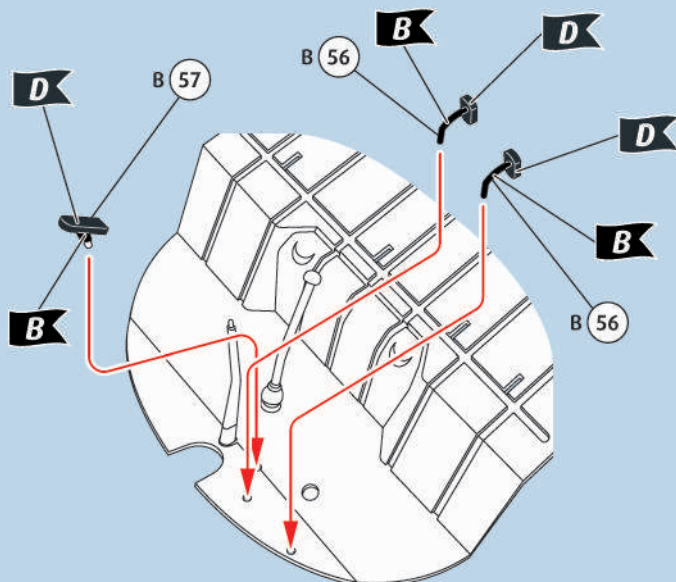
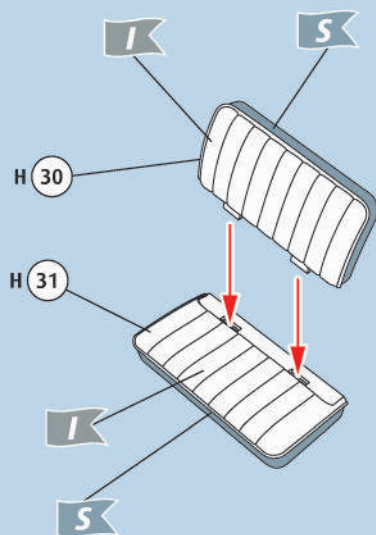
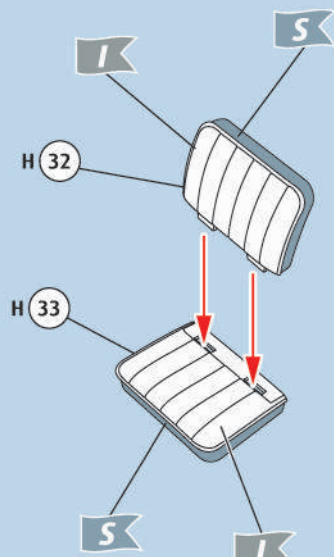
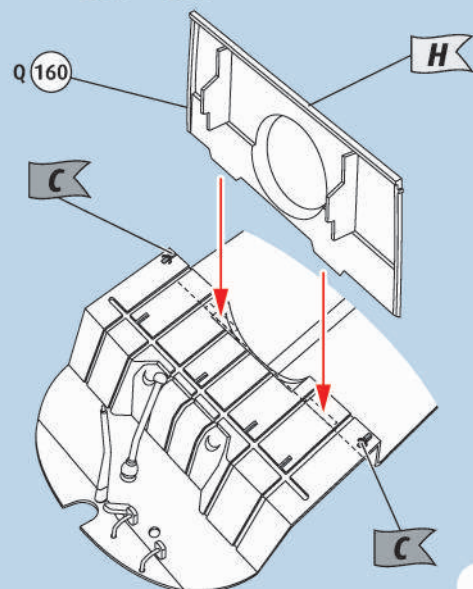
7  8  9  10  11  12  13  

14 

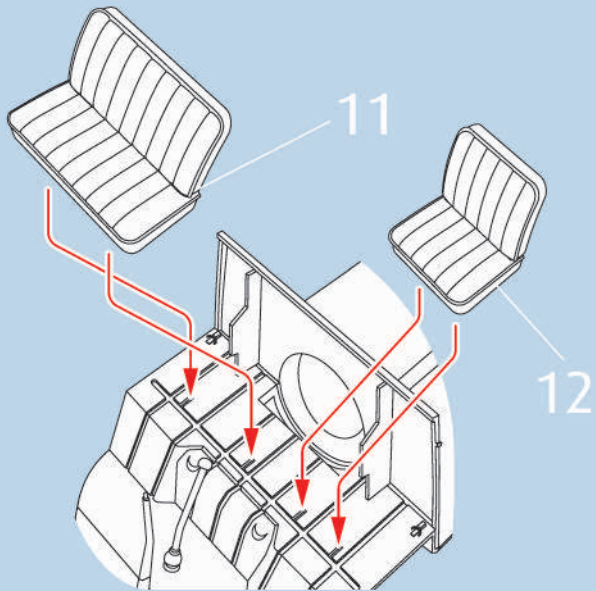

15  

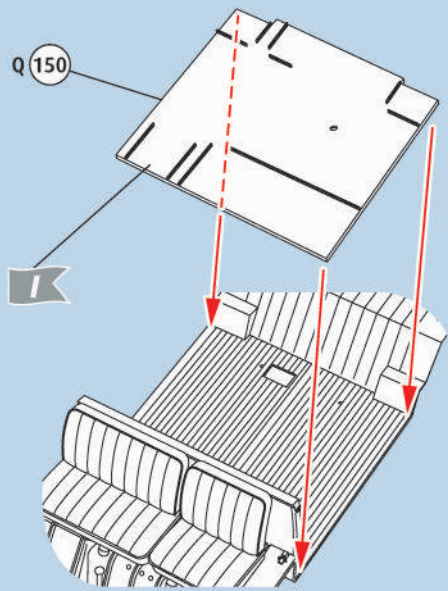

16    

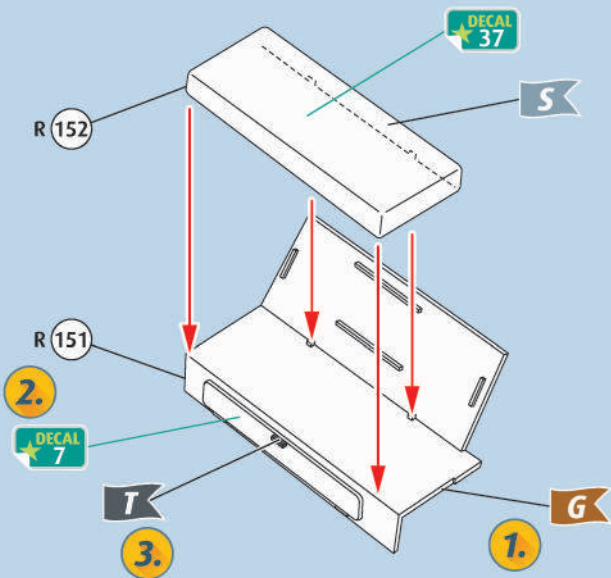

17    

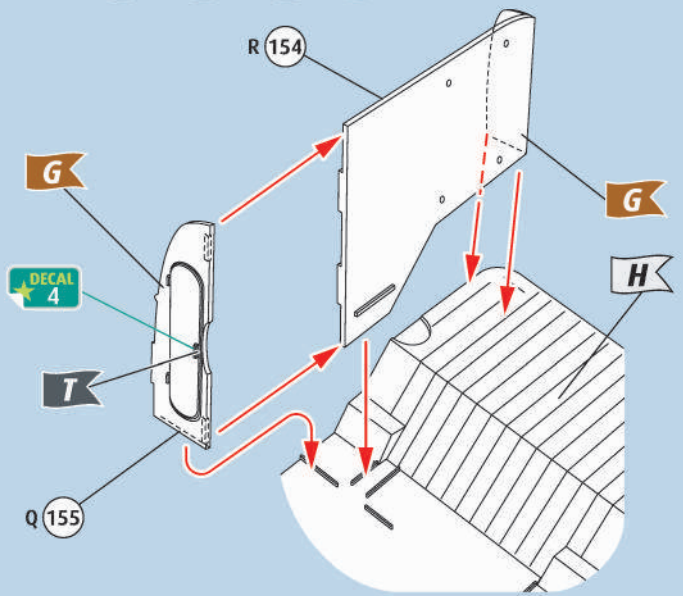

18    

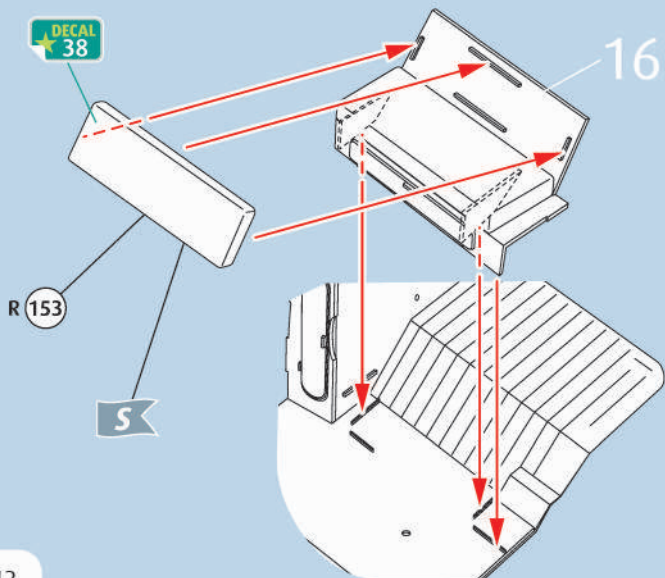

19    

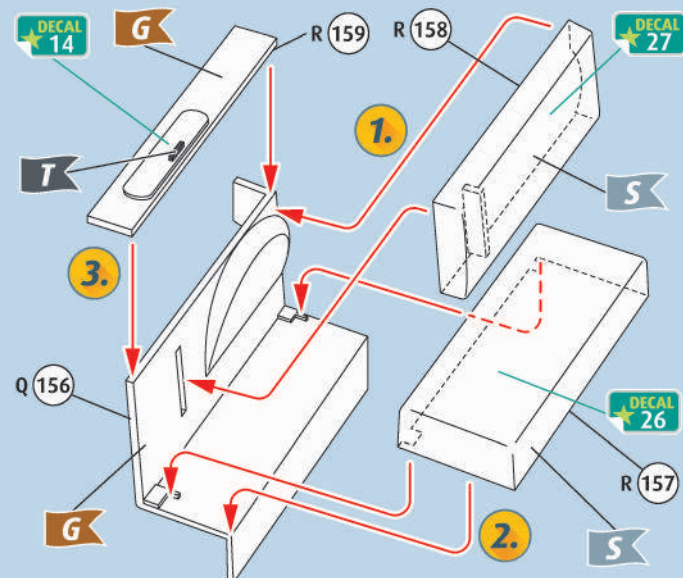

20     

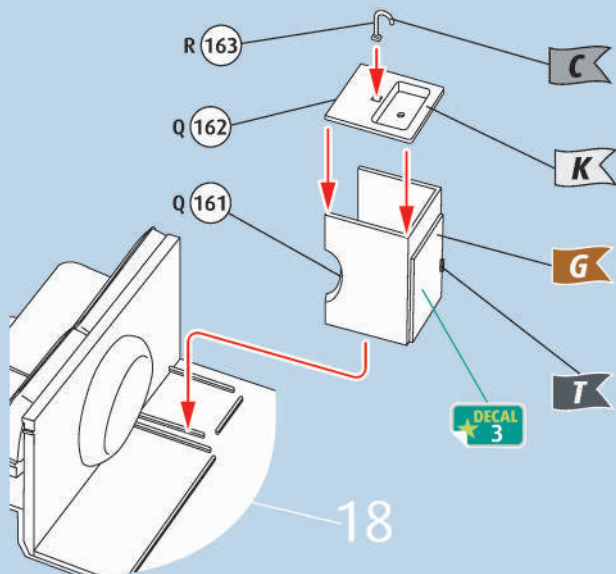

21 

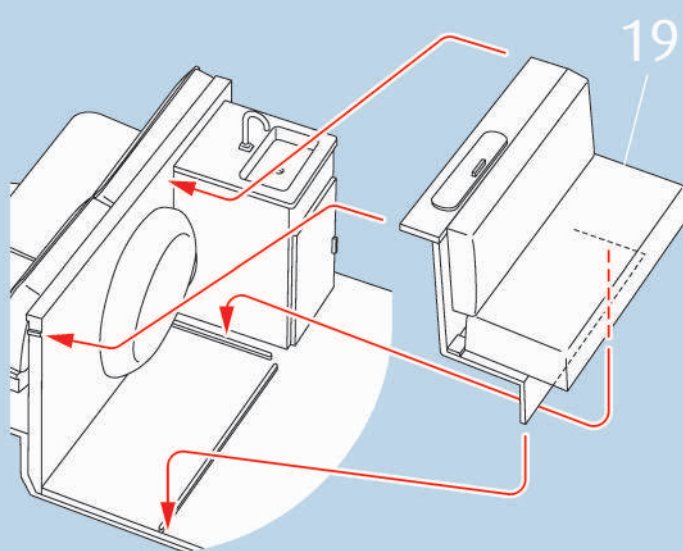

22 

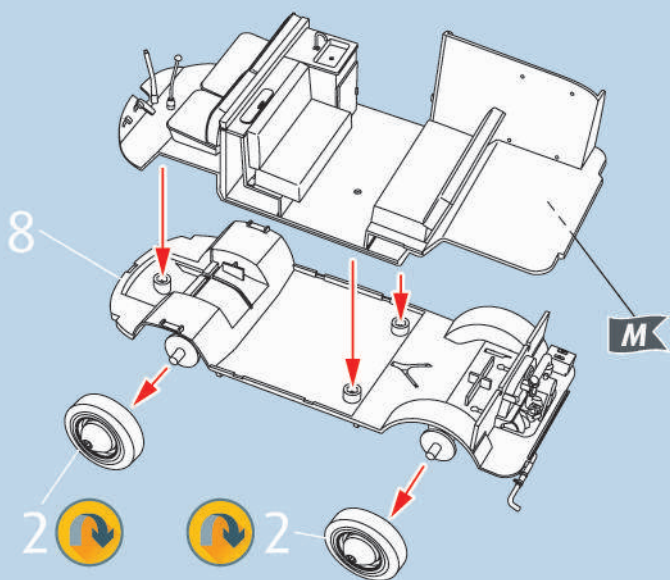

23   

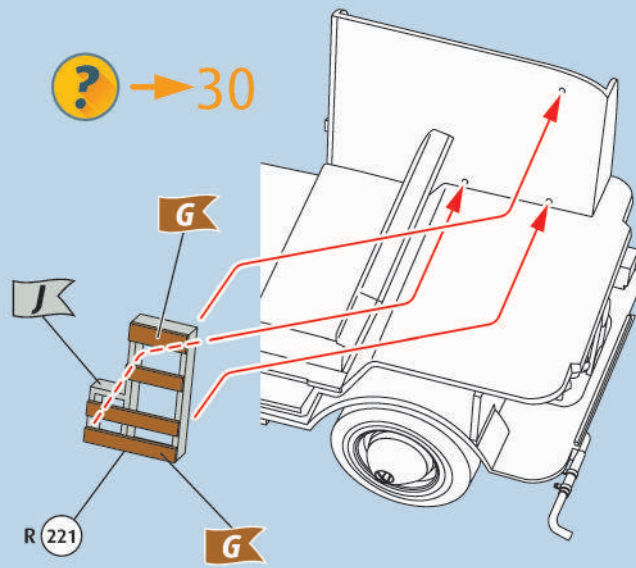

24    

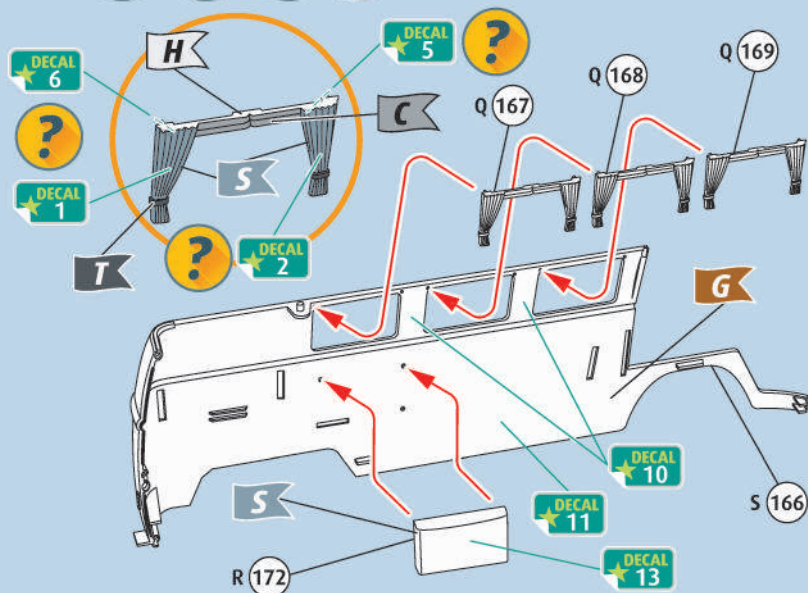

25    

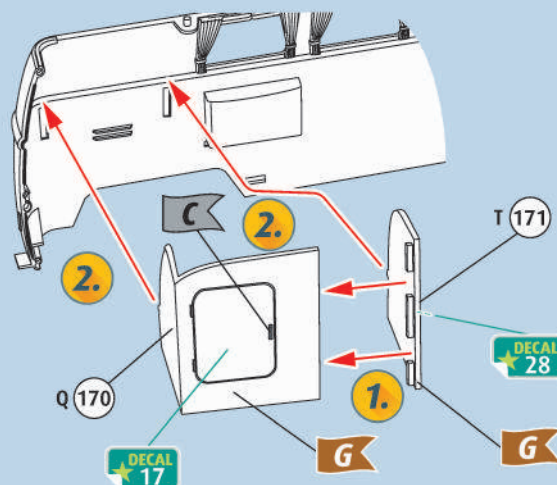

26    

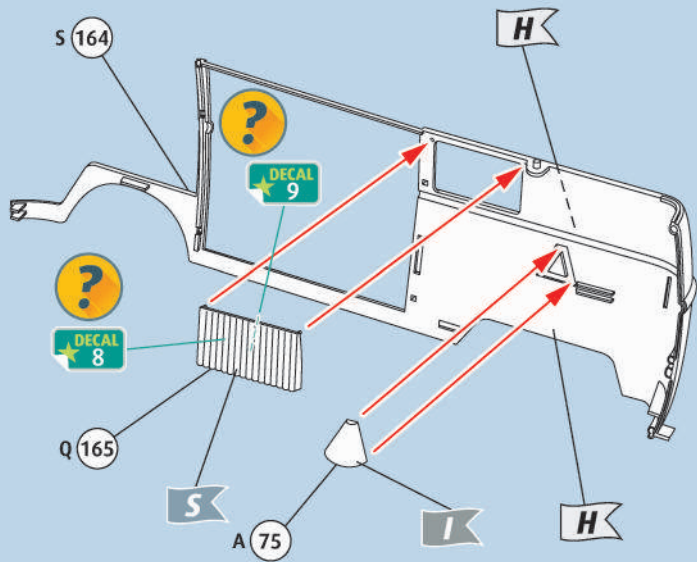

27  

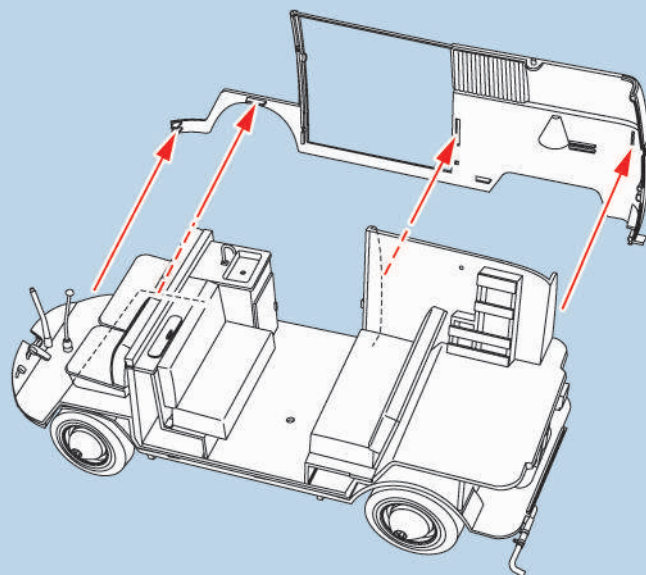

28   

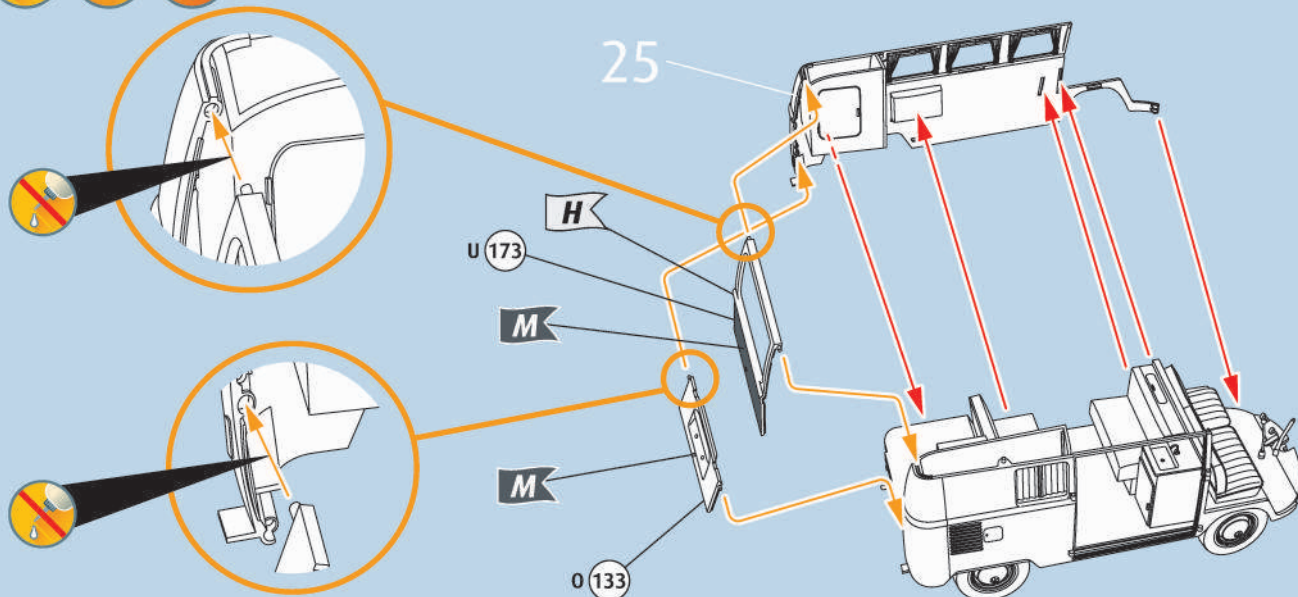

29  

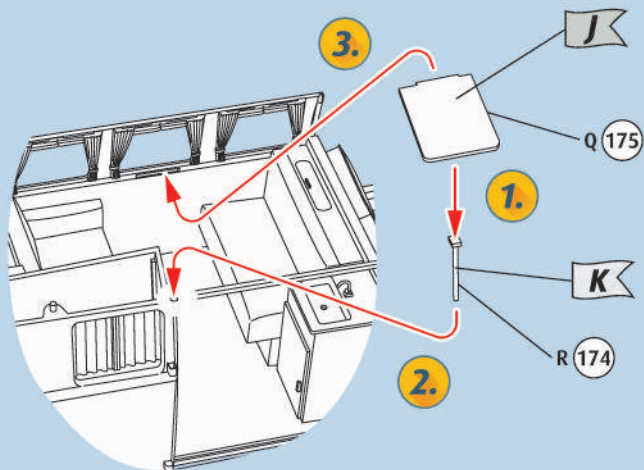

30     

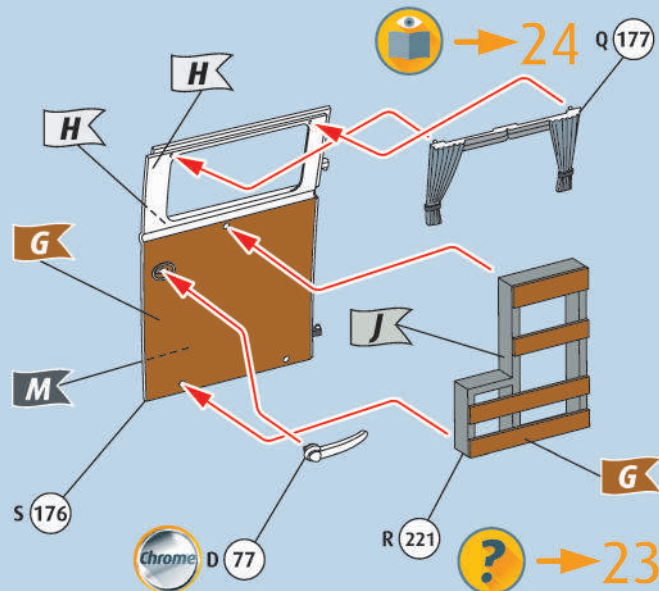

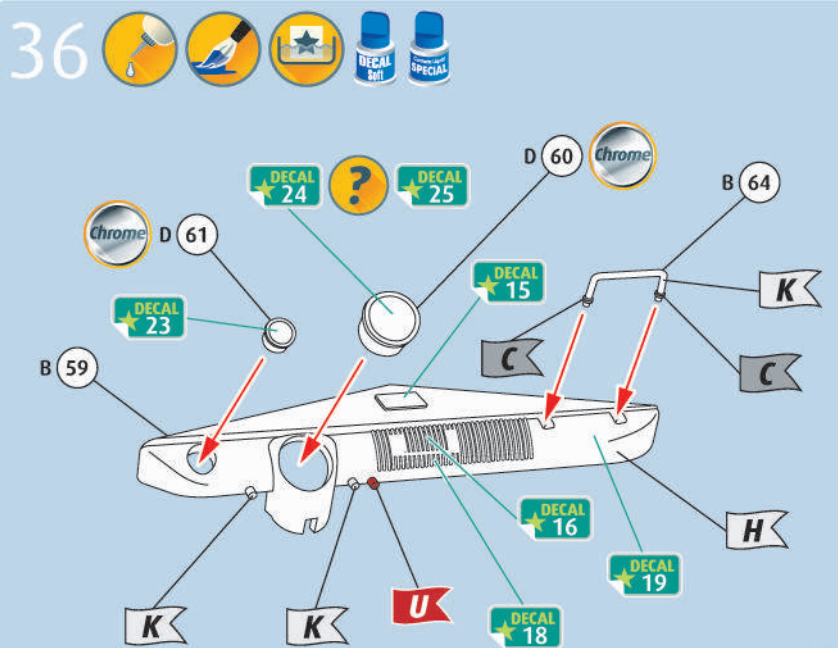
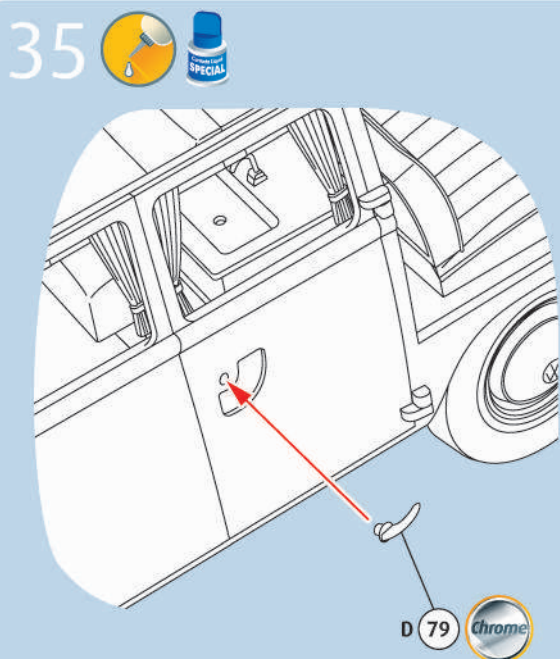
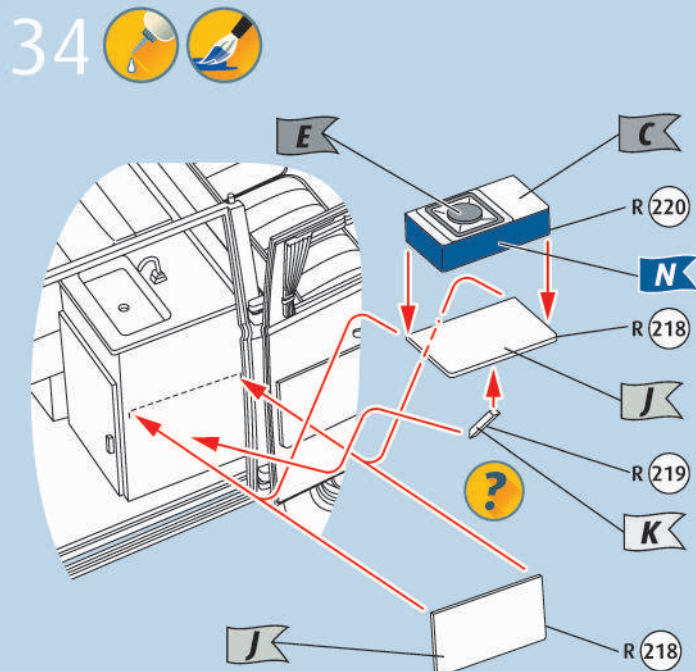
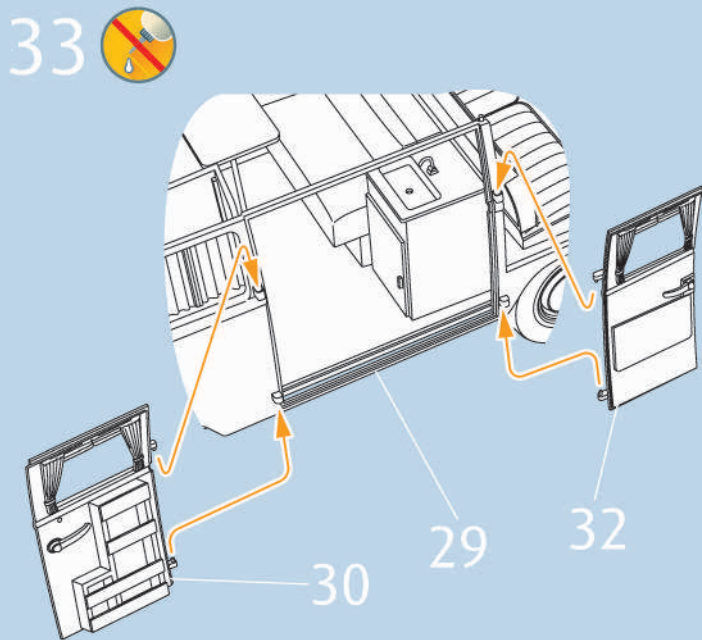
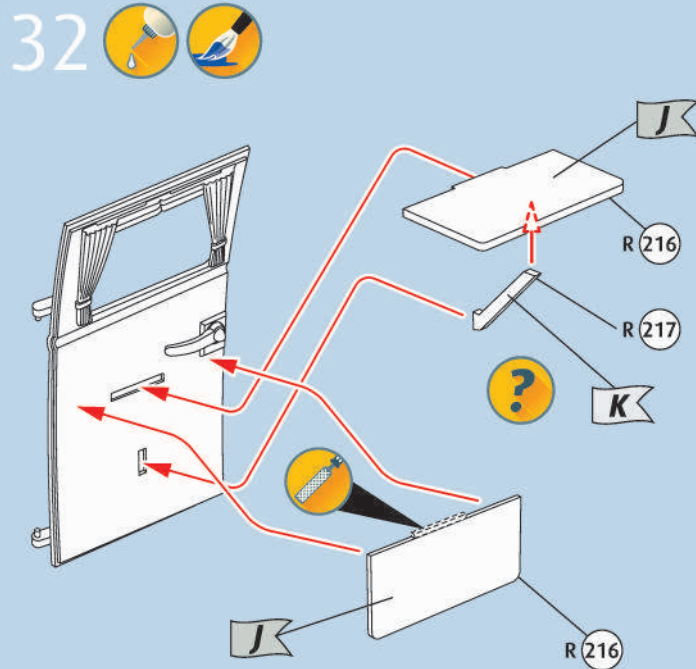
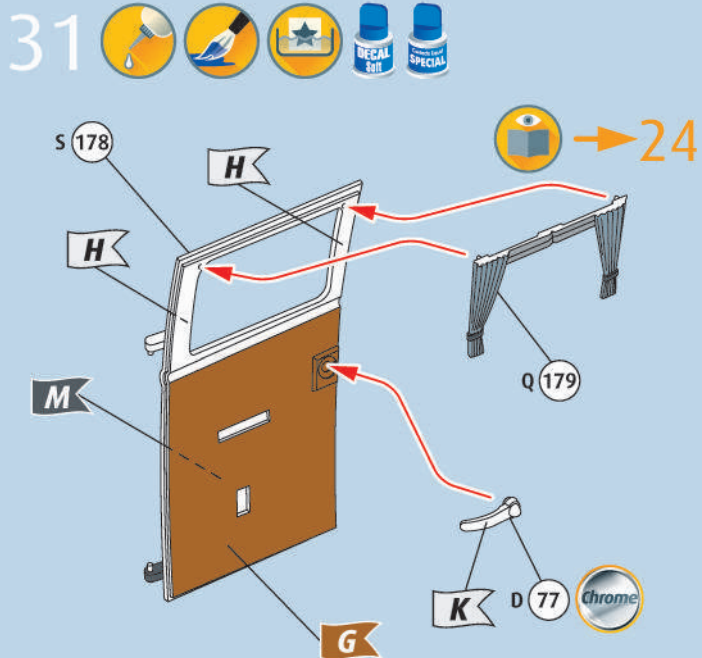

37

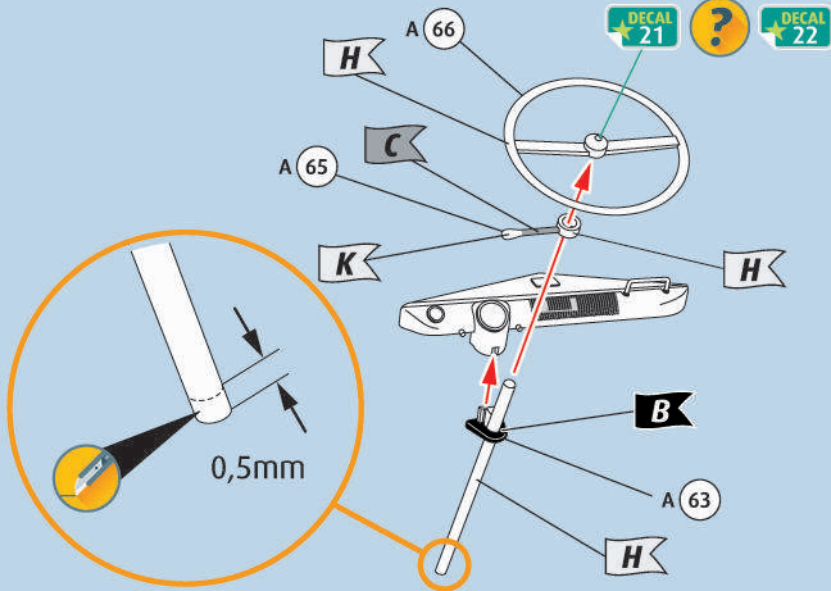

38

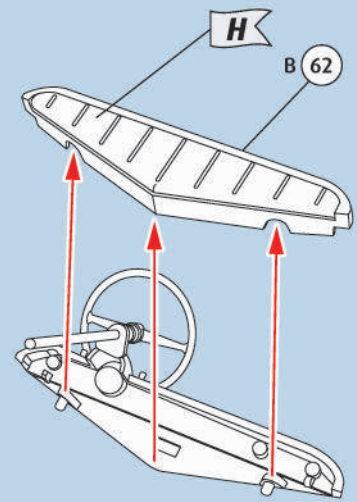

39

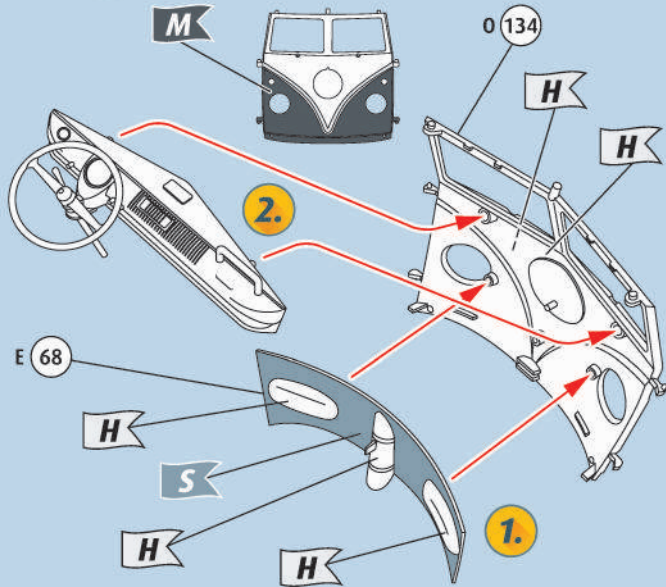

40

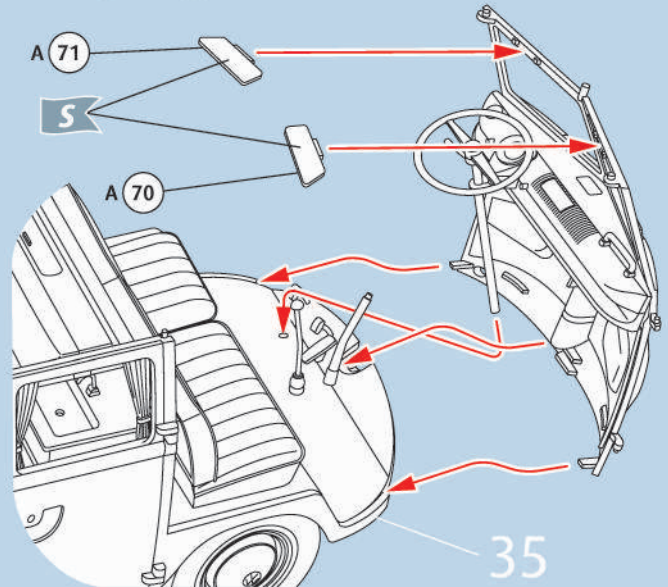

41

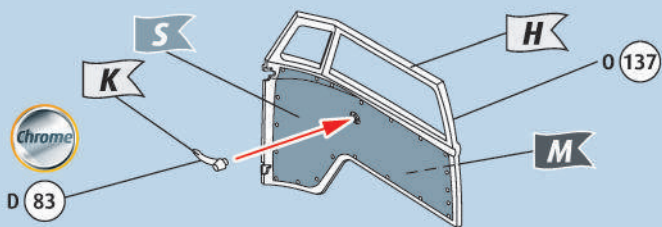

43

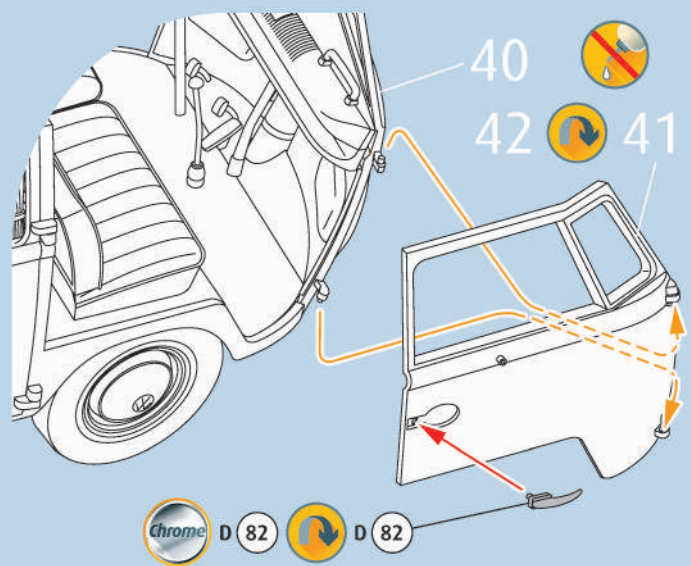

42

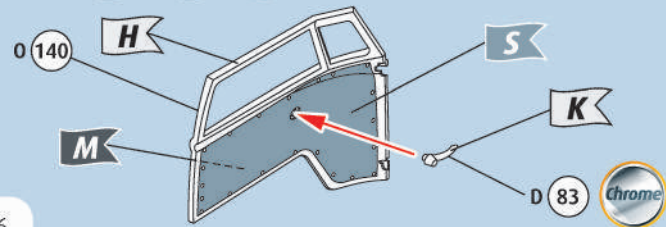

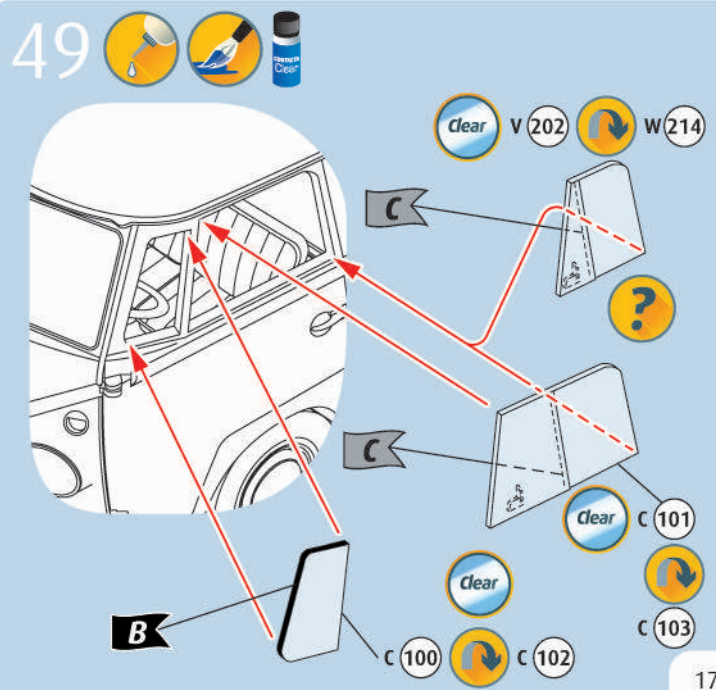
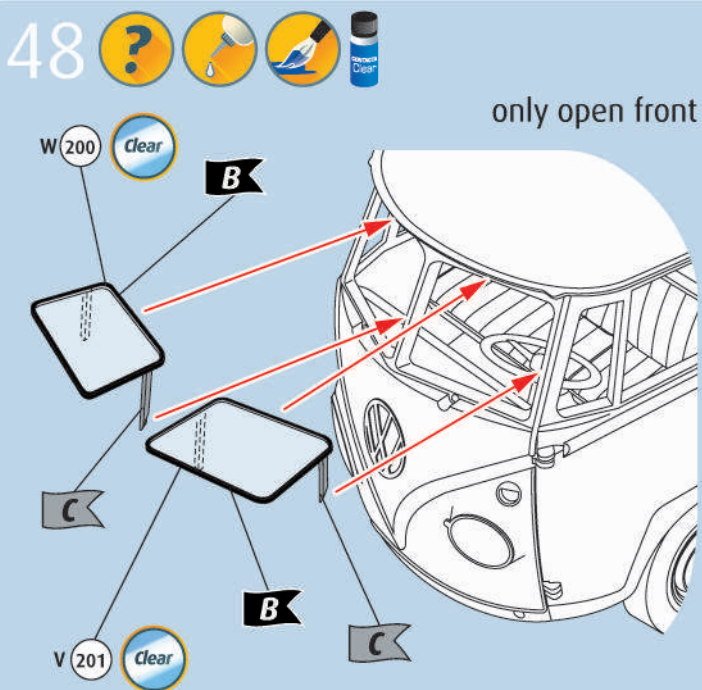
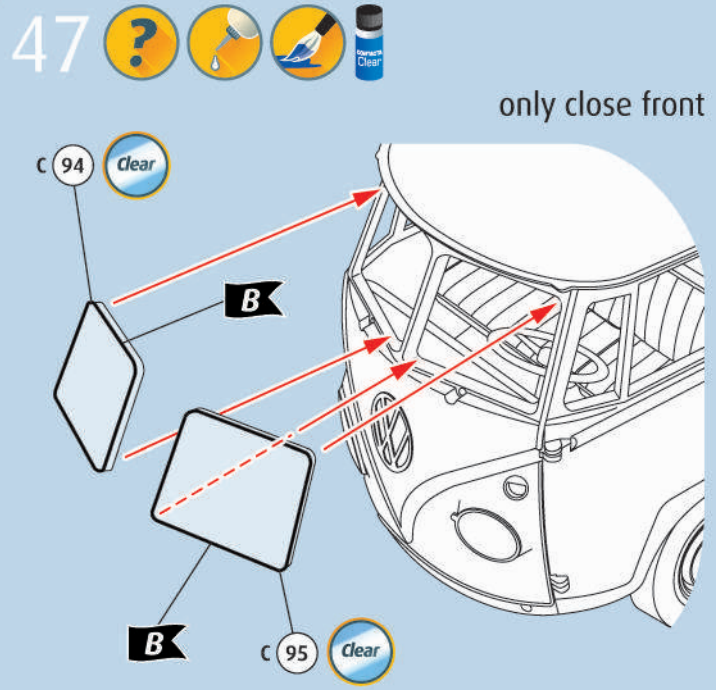
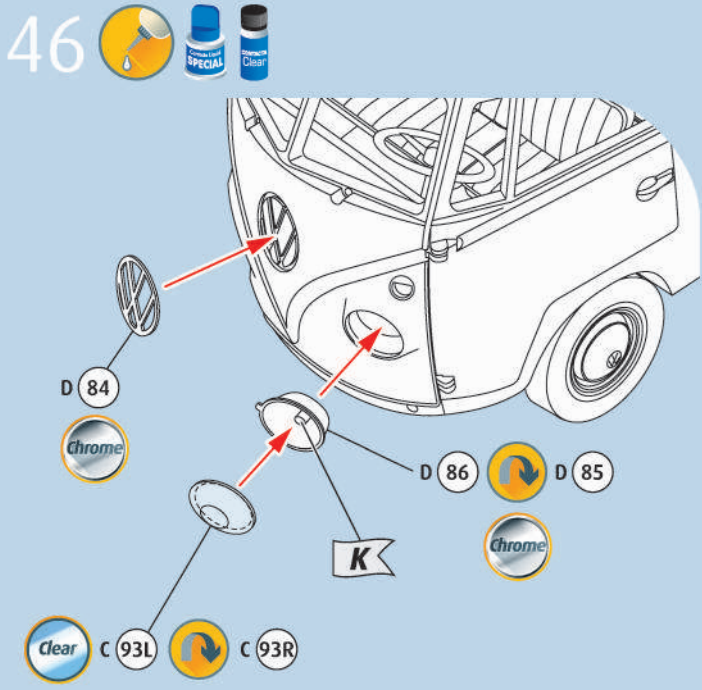
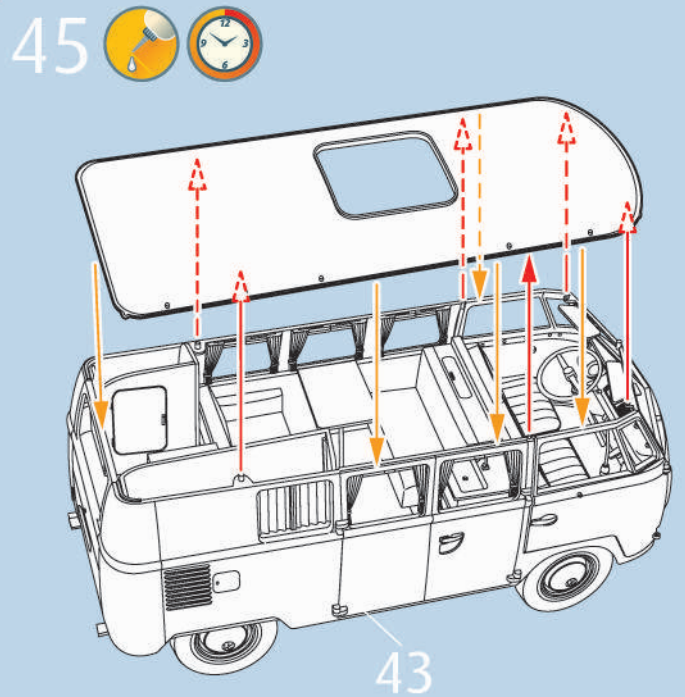
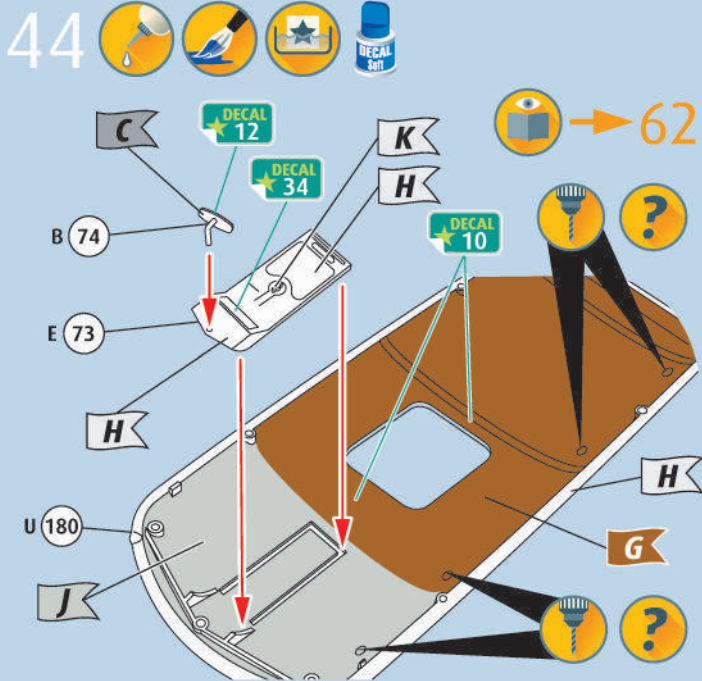

50 

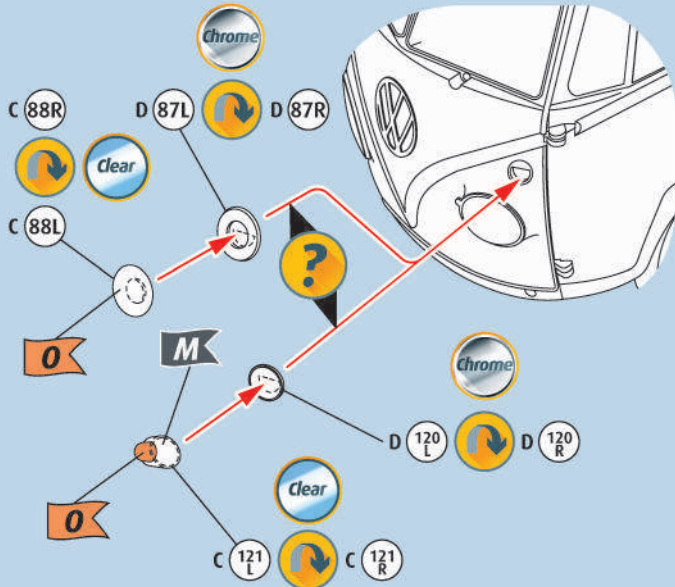

51 

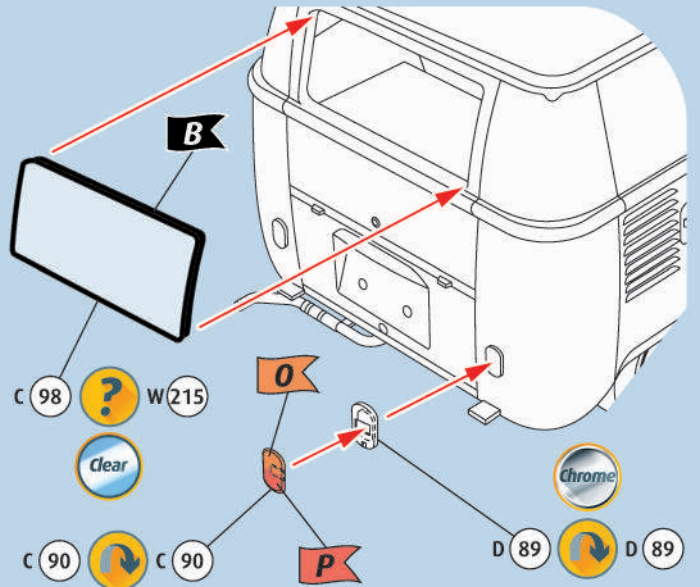

52 

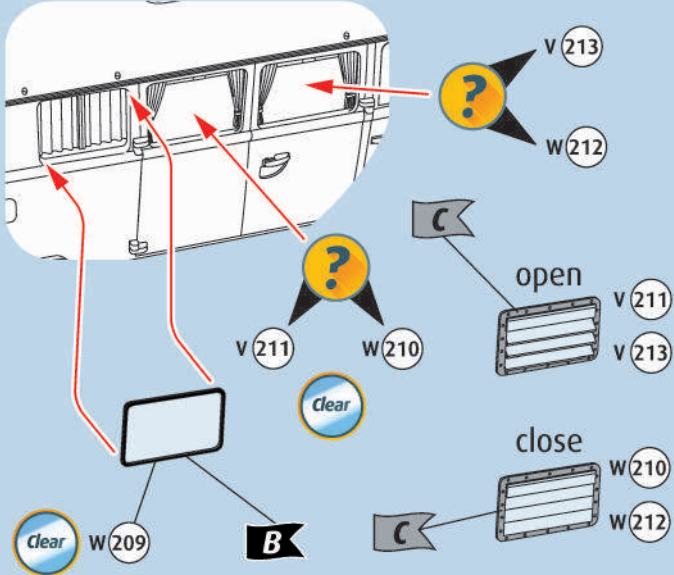

53 

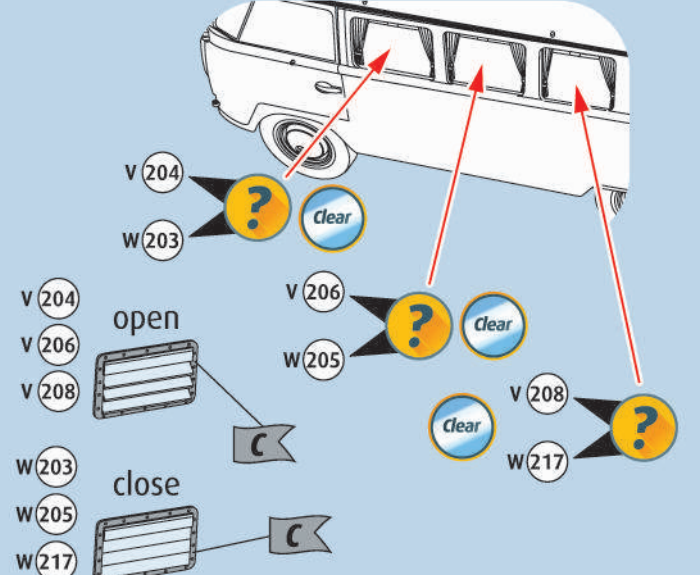

54 

only open roof

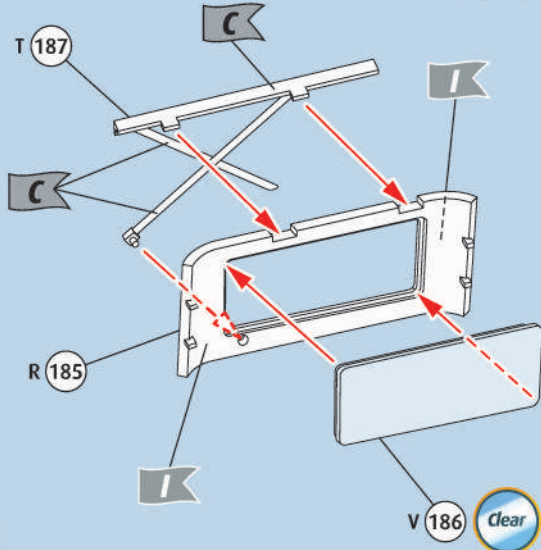

55 

only open roof

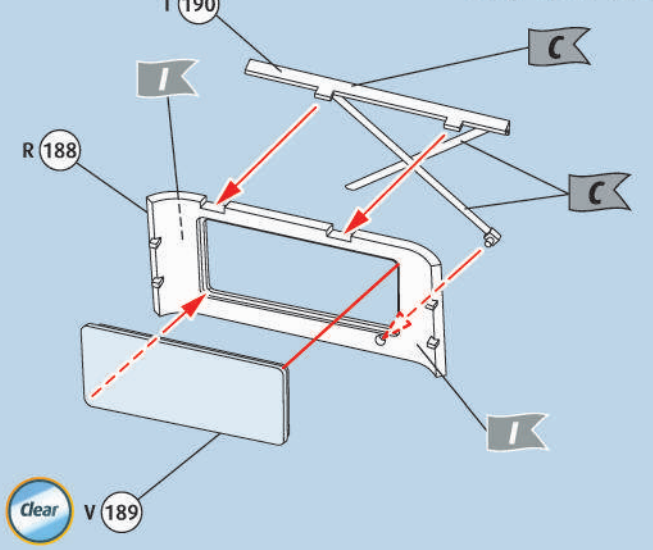

56



only open roof

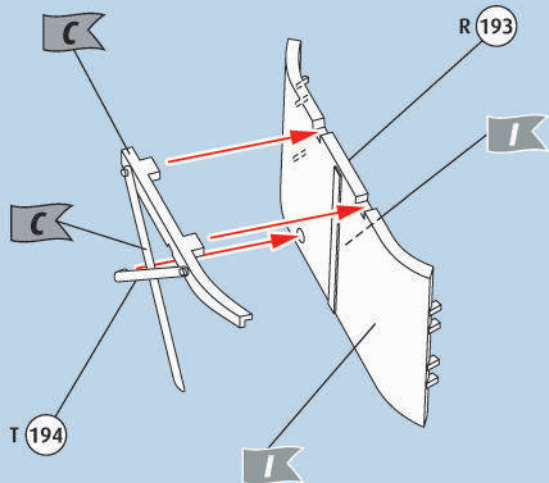

57



only open roof

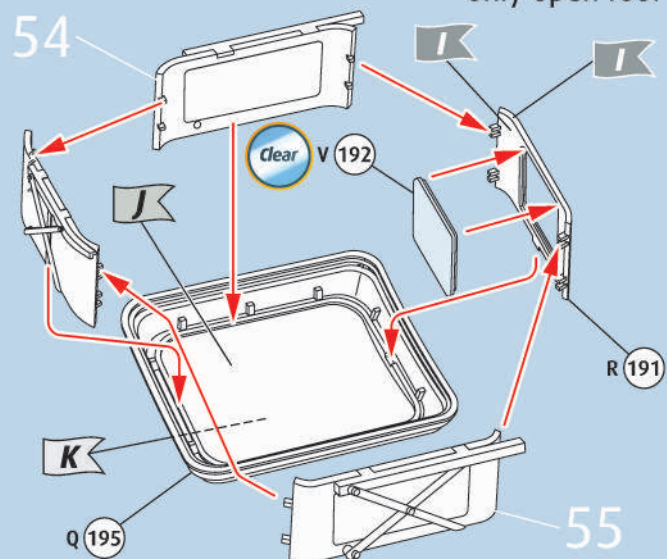

58

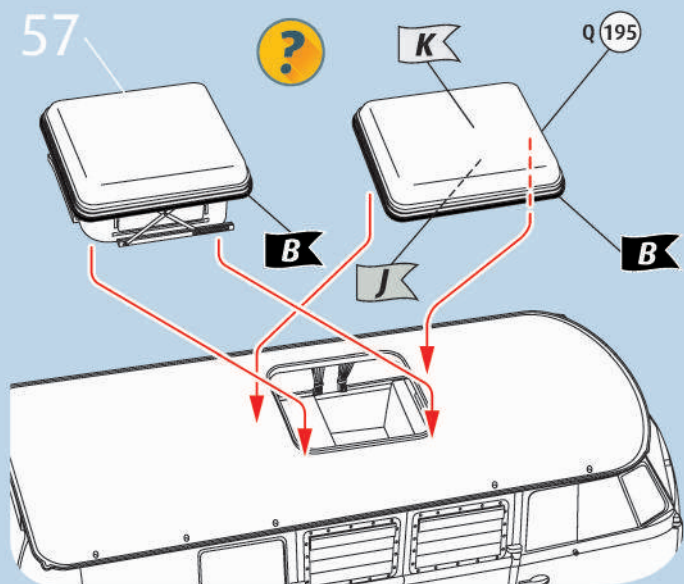

59

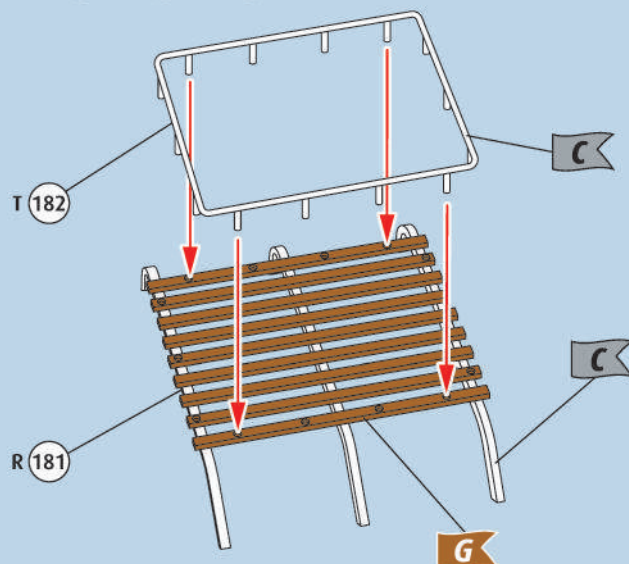

60

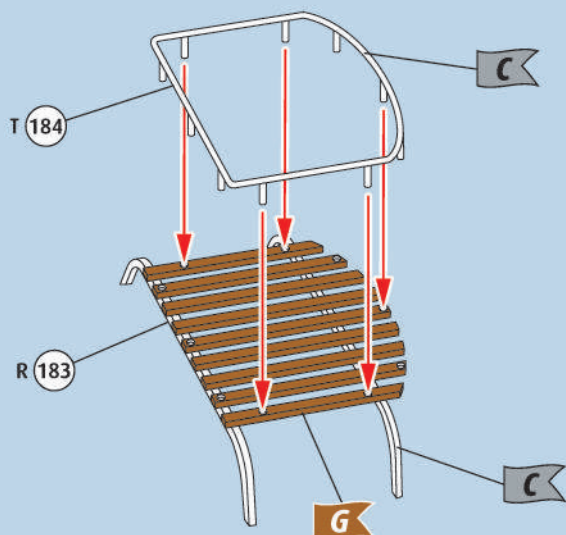

61

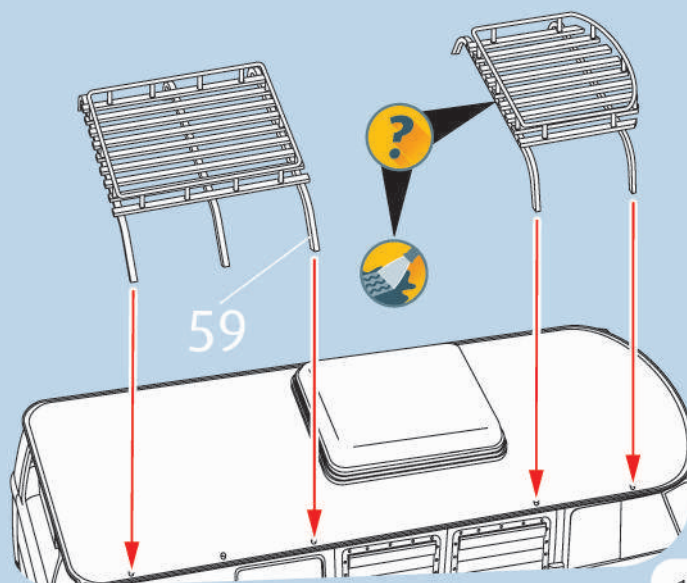

62

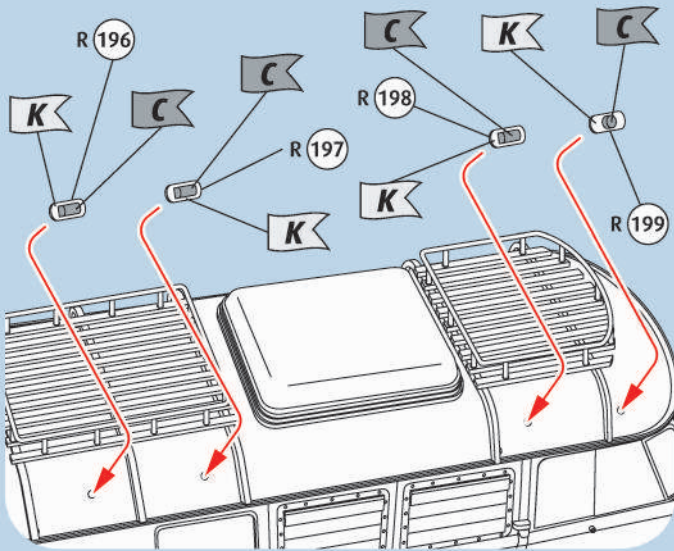

63

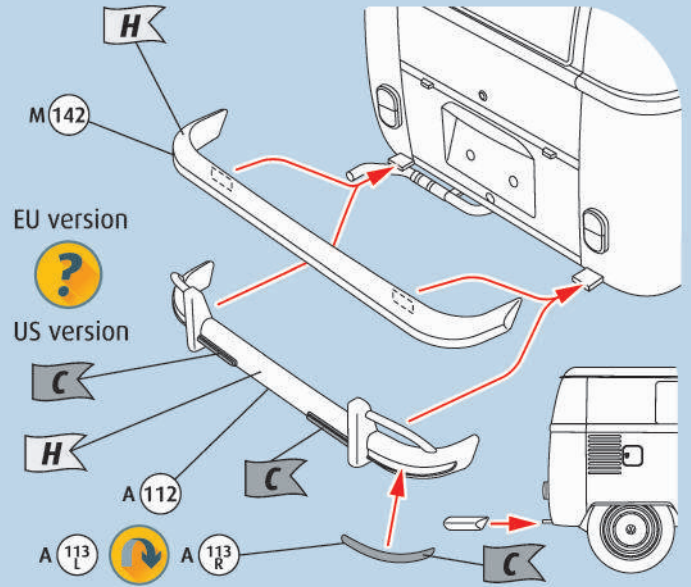

64

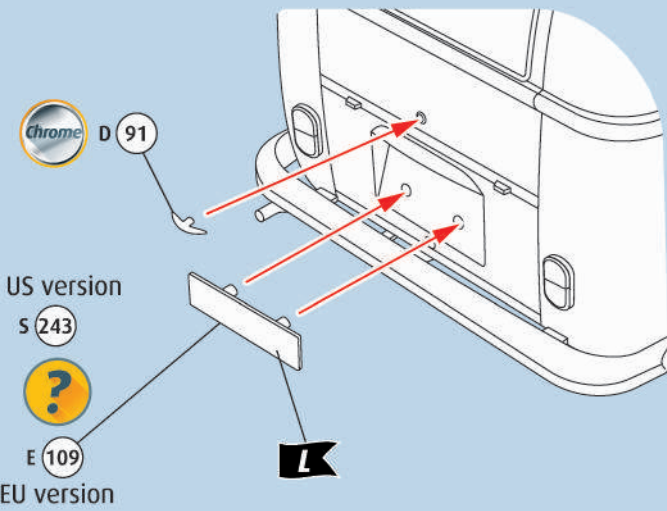

65

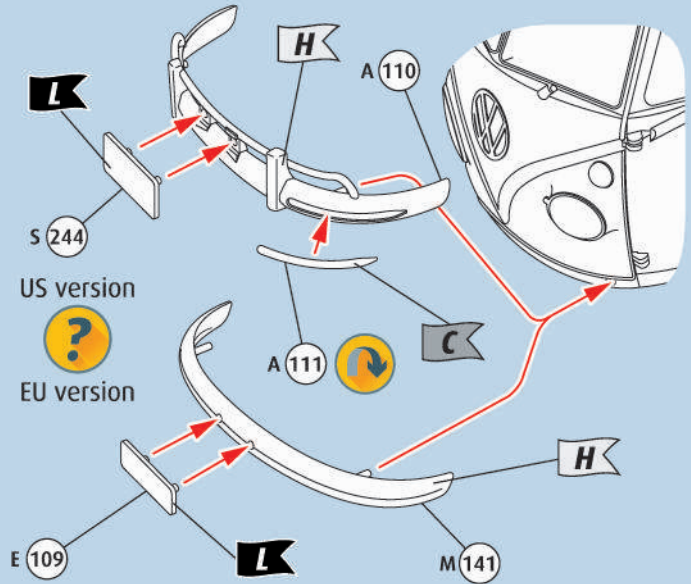

66

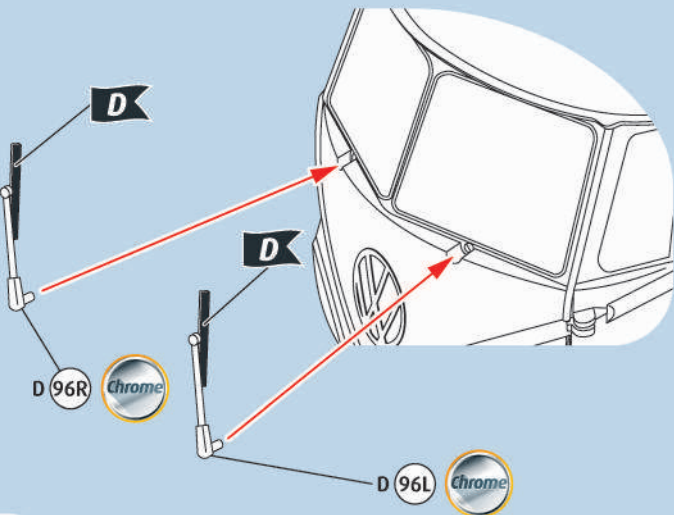

67

