

Historie

Firma Short byla jednou z největších firem, které se věnovaly vývoji a výrobě létajících člunů. Ve třicátých létech minulého století, kdy celokovové jednoplošníky začaly vytlačovat dvouplošníky, Short vyvinul několik variant civilních čtyřmotorových celokovových létajících člunů S.23, 30 a 33, souhrnně označovaných C-Class nebo Empire Class. Část z nich dostala vojenské vybavení a používaly se i bojově. Zkušenosti s výrobou a provozem těchto člunů se projeví v konstrukci stroje Short S.25. Ten byl navržen podle specifikací R.2/33, požadujících létající člun dalekého doletu určený k protiponorkovému hlídkování a k průzkumu. Čtyřmotorový celokovový stroj, jehož první prototyp vzletl poprvé 16. října 1937 dostal pojmenování Sunderland Mk.I. Sunderlany Mk.I byly vybaveny motory Pegasus Mk.XXII, střeleckými věžemi v přídi a zádi a otevíratelnými střelišti na hřbetě trupu. Bylo jich vyrobeno 90 ks, část z nich u firmy Blackburn. Verze Sunderland Mk.II dostala hřbetní střeleckou věž a silnější motory Pegasus Mk.XVIII. Společná výroba u Shortu a Blackburnu dal vzniknout 43 kusům této verze. Na některých kusech této verze byly použity první verze radarů se stromečkovitými anténami ASV Mk.II. Zkušenosti z bojů vedly k úpravám Sunderlandu. Výroba přešla na verzi Mk.III/IIIA. Trup této verze dostal nové, aerodynamicky výhodnější stupně křídla, ASV radar Mk.III v kapkovitém výstupku pod křídlem. Pozdější vyrobené kusy dostaly do příde výzbroj čtyř pevných kulometů určených k boji s obsluhami protiletadlových zbraní na vypoňených ponorkách. Celkem bylo vyrobeno 456 kusů trojek. Vzhledem k tomu, že zvětšená verze Sunderland Mk.IV, později přeznačená na Seaford Mk.I se nevyráběla sériově, poslední verzi Sunderlandu v sériové výrobě se stala verze Sunderland Mk.V. Dostala americké motory P&W R-1830-90B a radar ASV Mk.VIC. Výroba byla ukončena až v červnu 1946 po vyrobení 150 kusů. Sériové Sunderlany Mk.I dostala jako první No.230 sqn. RAF v roce 1938. Na konci války se Sunderlany létalo dvacet squadron pod velením RAF a další squadrony pod velením spojeneckým. Bojovaly od prvního dne války až do jejího konce. Během válečných let se nesporně osvědčily. Nasazeny byly v nad oceány od Atlantiku, přes Indický oceán až po Pacifik. Spolehlivě sloužily na chladném severu v polárních oblastech, stejně jako v tropech. Vysloužily si, pro svou obrannou výzbroj, pojmenování létající dikobraz. Konec války neznamenal konec jejich služby. Sunderlany RAF se mohou pochlubit mimo jiné účastí v Korejském konfliktu, Berlinském mostu nebo bojů s komunistickými bojovkami v Malajsku. Kromě britského RAF létaly v řadách australského, novozélandského, norského, jihoafrického a kanadského letectva, francouzského a portugalského námořnictva. U většiny zahraničních uživatelů již během války. Poslední novozélandské Sunderlany byly přitom vyřazeny až v roce 1967!

CZ

TTD verze Mk.II

Rozpětí: 34.39 m, Délka: 26.11 m, Výška: 10.01 m, Max. rychlost: 329 km/h v 1900 m, Operační dostup: 5243 m, Dolet: 3027 km v 1880 m, Vytrvalost: 10/21 hodin při rychlosti 260/220 km/h, Výzbroj: 2000 kg bomb či hlubinych bomb, 8x kulomet 7.7 mm

History

Short Brothers were one of the largest aircraft producers to undertake the development and manufacturing of multi engine flying boats. In the 1930s, when monoplanes of all metal construction were beginning to have the upper hand over biplane aircraft designs, Short Brothers developed a couple of all metal, four engine flying boats for the civilian market - these aircraft were known as the S.23, S.30 and S.33, or generally as the C-Class or Empire Class. Some of the machines were fitted with military equipment and saw service in the force. The experience gained during the production and operational service of these boats proved to be essential for the development of their successor, the Short S.25, which was designed to Specification R.2/33 that called for a long range flying boat suitable for anti submarine patrol and reconnaissance missions. The prototype of this aeroplane first took to the air on 16 October 1937 and got the name Sunderland Mk.I. The production machines were powered by Pegasus Mk.XXII engines and had gun turrets in the bow and stern and a pair of manually operated machine guns on either side of the upper fuselage. As many as ninety of them were produced, some of them at the Blackburn plant. The following variety, the Mk.II was fitted with a dorsal gun turret and more powerful engines in the shape of the Pegasus Mk.XVIII. The Short and Blackburn plants produced in total 43 airframes of this mark, some of which were experimentally equipped with the first generation of ASV Mk.II radars with an array of tree-like antennae. Combat experience gained in the field even led to a couple more improvements which enabled the production of the Mk.III/IIIA version. The hull was reshaped at the keel step and got a much smoother profile and the machines also had a new type of ASV radar fitted under their wings, where the radar dishes were placed in large teardrop-shaped housings. Later machines were even equipped with four fixed machine guns in their nose sections, which were meant to be used against anti-aircraft defence of emerged German submarines. In total, 456 of the Sunderland Mk.III were produced. A production of an enlarged variety, known as the Sunderland Mk.IV (later renamed to Seaford Mk.I) was also planned, though it never materialised. The final version of this flying boat was the Mk.V, which was powered by American P&W R-1830-90B units, used ASV Mk.VIC radar equipment and was in production until June 1946, giving in total 150 machines. The first production Mk.I machines saw operational service with No.230 Sqn of the RAF, and by the end of the War, twenty RAF units operated the Sunderland along with a few more of the Allied forces. The Sunderland proved useful for the Allied war effort right from the outset of the hostilities and remained so until the end of the conflict. These flying boats were operated over the vast expanses of the Atlantic Ocean as well as the Indian Ocean and the Pacific and proved to provide reliable service in such different environments as the cold polar areas and over the tropical seas. For their heavy armament, they got the nickname the 'Flying Porcupine'. The end of the horrible world conflict did not manage to bring the faithful service of the Sunderland to an end. These magnificent flying boats went on serving with the RAF in the Korean war, during the Berlin Airlift Operation and even fighting communist insurgents in Malaya. Besides the RAF, they flew with the Australian, New Zealandian, South African, Norwegian and Canadian air forces as well as with the French and Portuguese navies, in most cases already during the war. The last Sunderlands to fly were those operated by the RNZAF and they were struck off charge as late as 1967.

EN

Mk.II Specification / Performance

Wingspan: 34.39 m, Length: 26.11 m, Height: 10.01 m, Max. speed: 329 kph (1900 m), Service ceiling: 5243 m, Range at cruising speed: 3027 km (1880 m), Endurance: 10/21 hours at 260/220 km/h, Offensive ordnance: 2000 kg, Defensive armament: 8x 7.7 mm

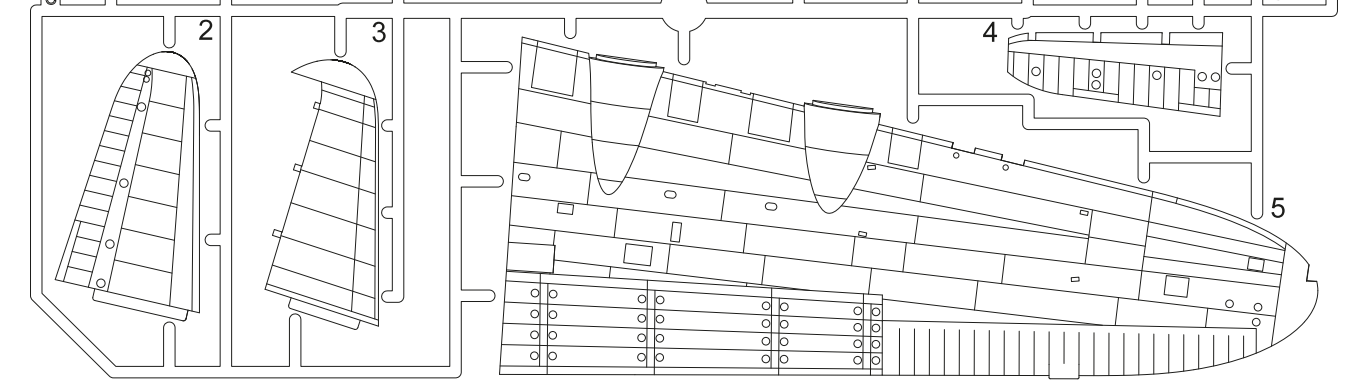
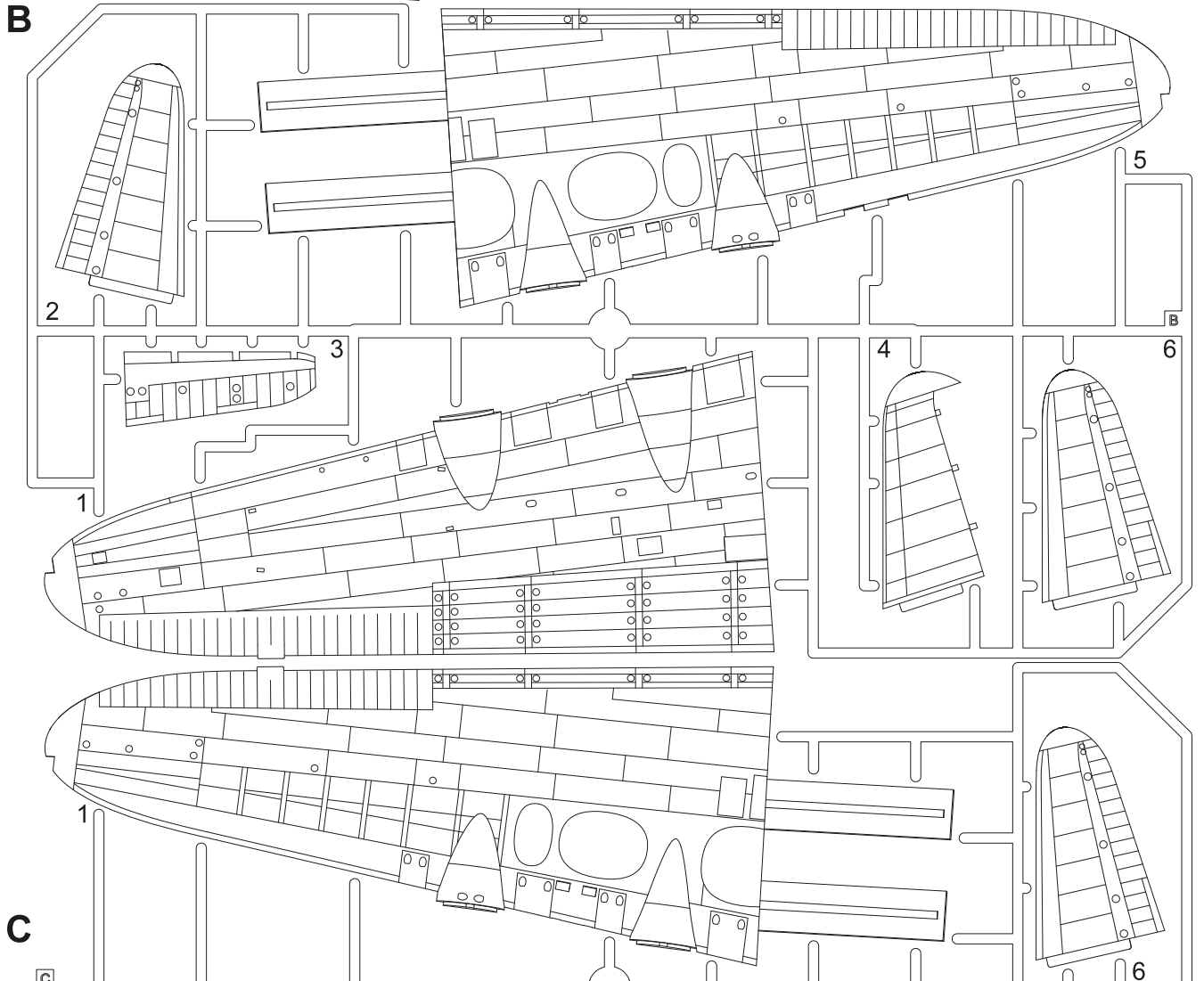
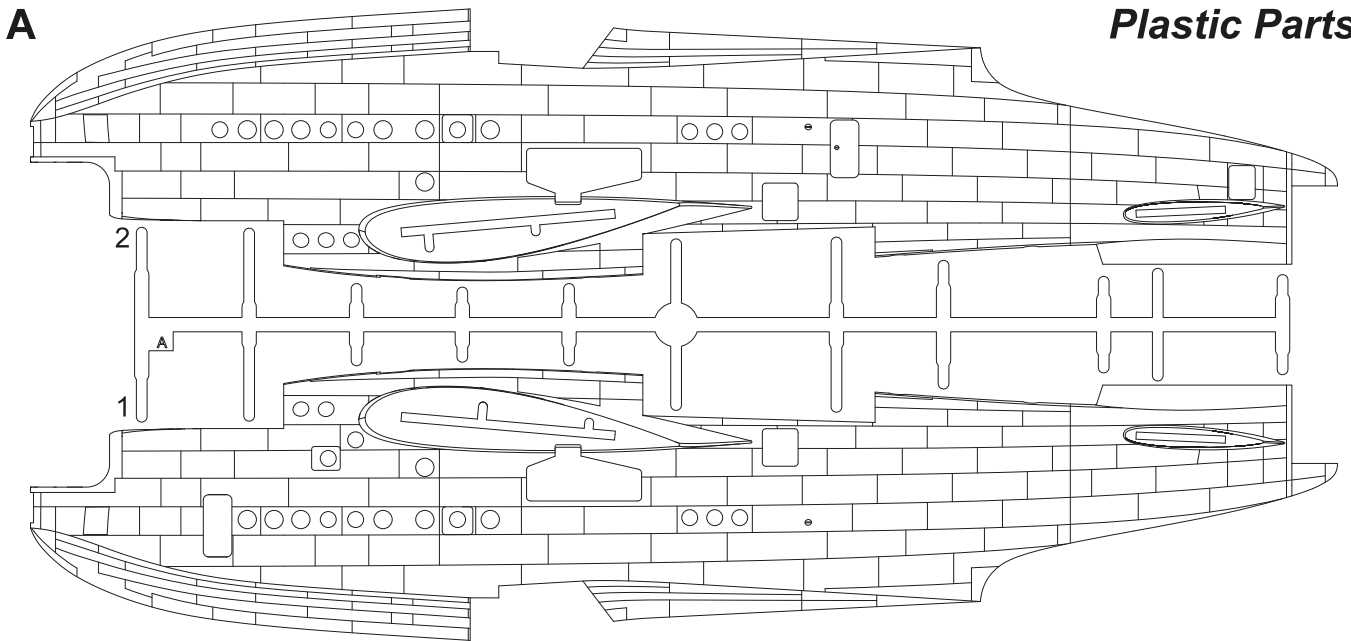

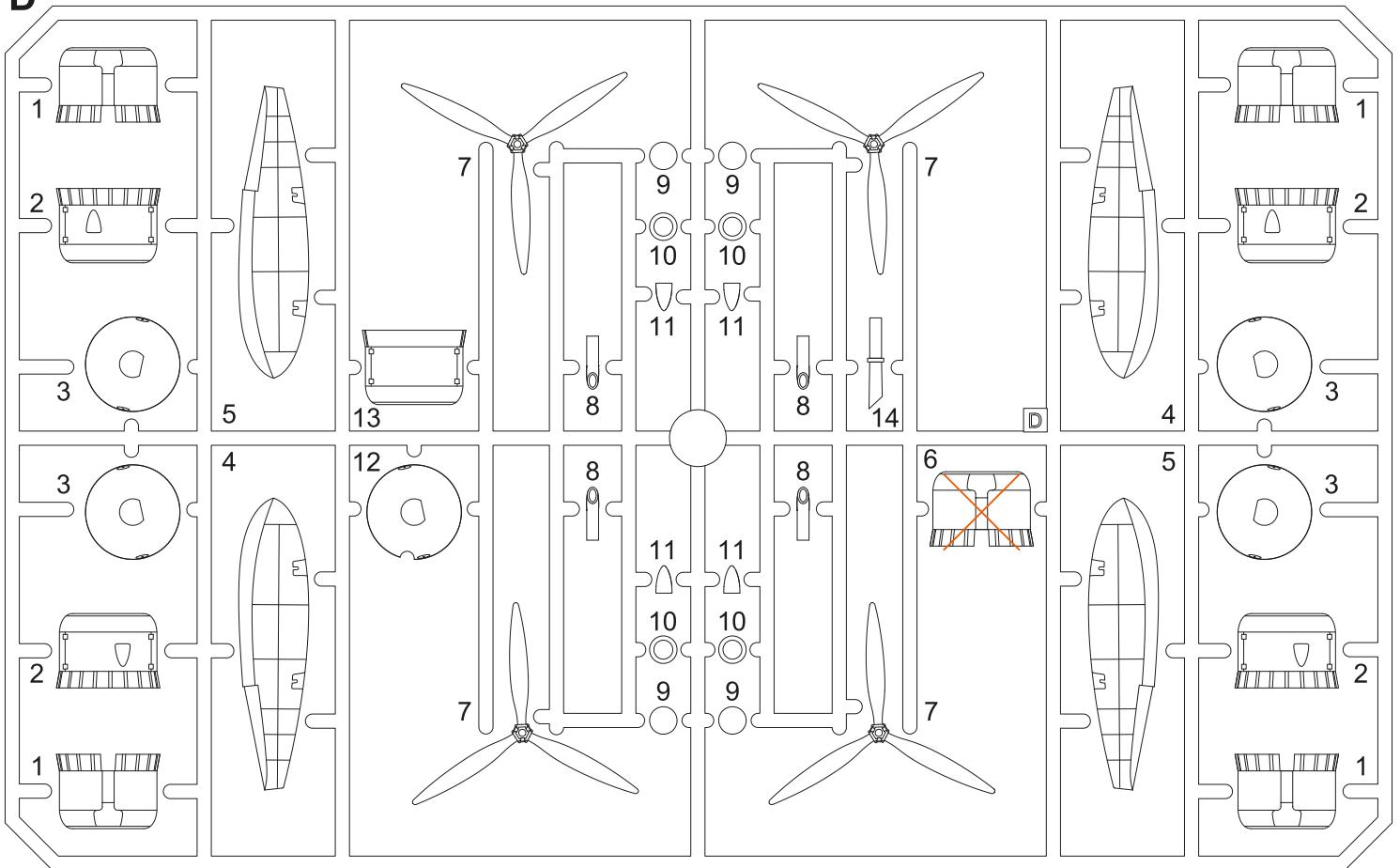
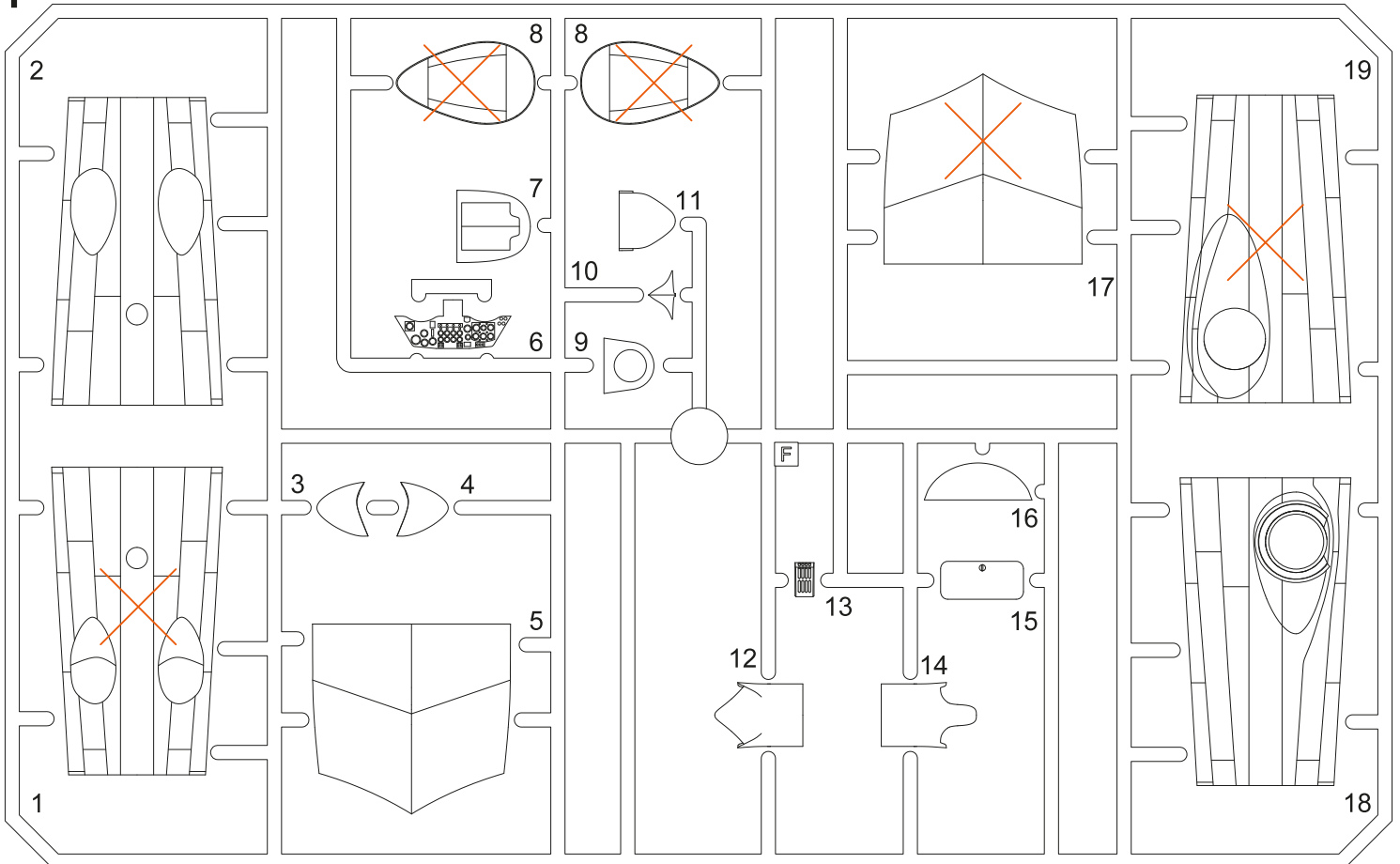
D**F****SYMBOLS**

 MOŽNOST VOLBY
OPTIONAL
NACH BELIEBEN
OPTION

 POUŽÍT KYANOAKRYLÁTOVÉ LEPIDLO
INSTANT CYANOACRYLATE GLUE
ZYANOAKRYLÁTKLEBER
COLLE CYANOACRYLAT

 OHNOUT
BEND
BIEGEN
COURBER

 ZHOTOVIT NOVÉ
SCRATCH BUILD
FERTIGSTELLEN
ACHEVER



ŘEZAT/VRTAT
CUT OFF/DRILL
ENTFERNEN
DETACHER

 GSI
colour code

 NATŘÍT
COLOUR
FARBEN
PEINDRE

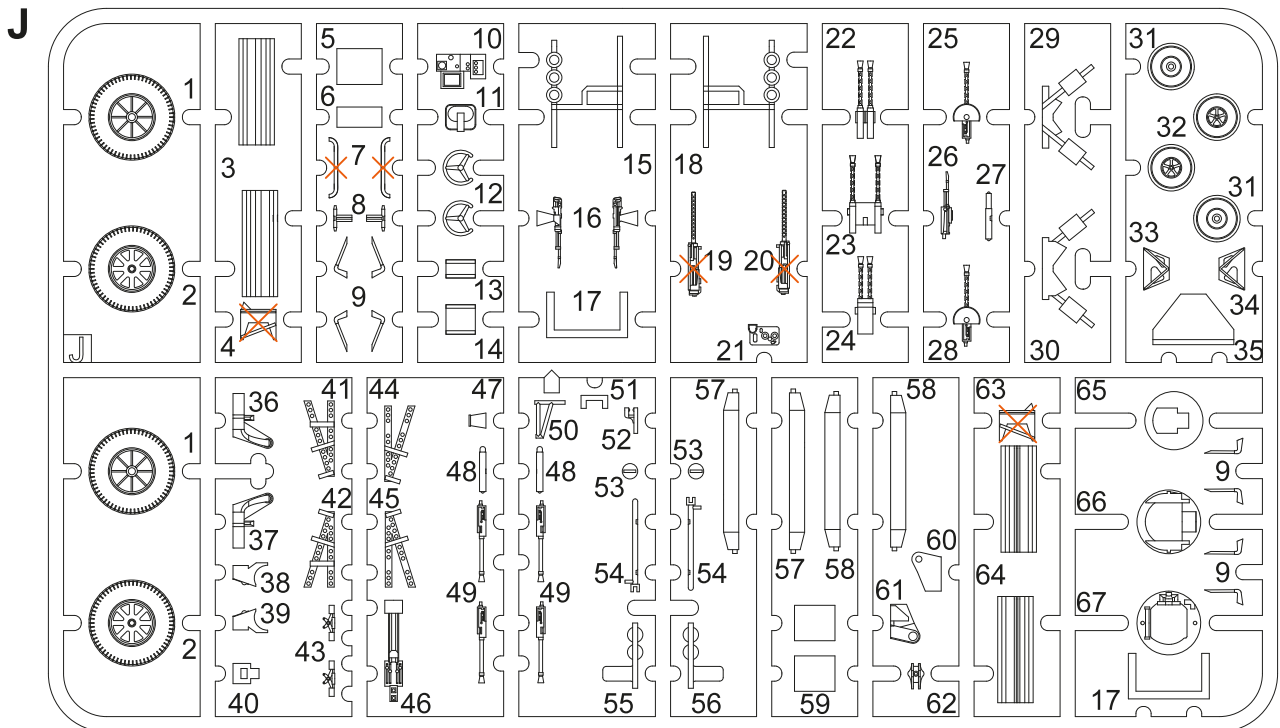
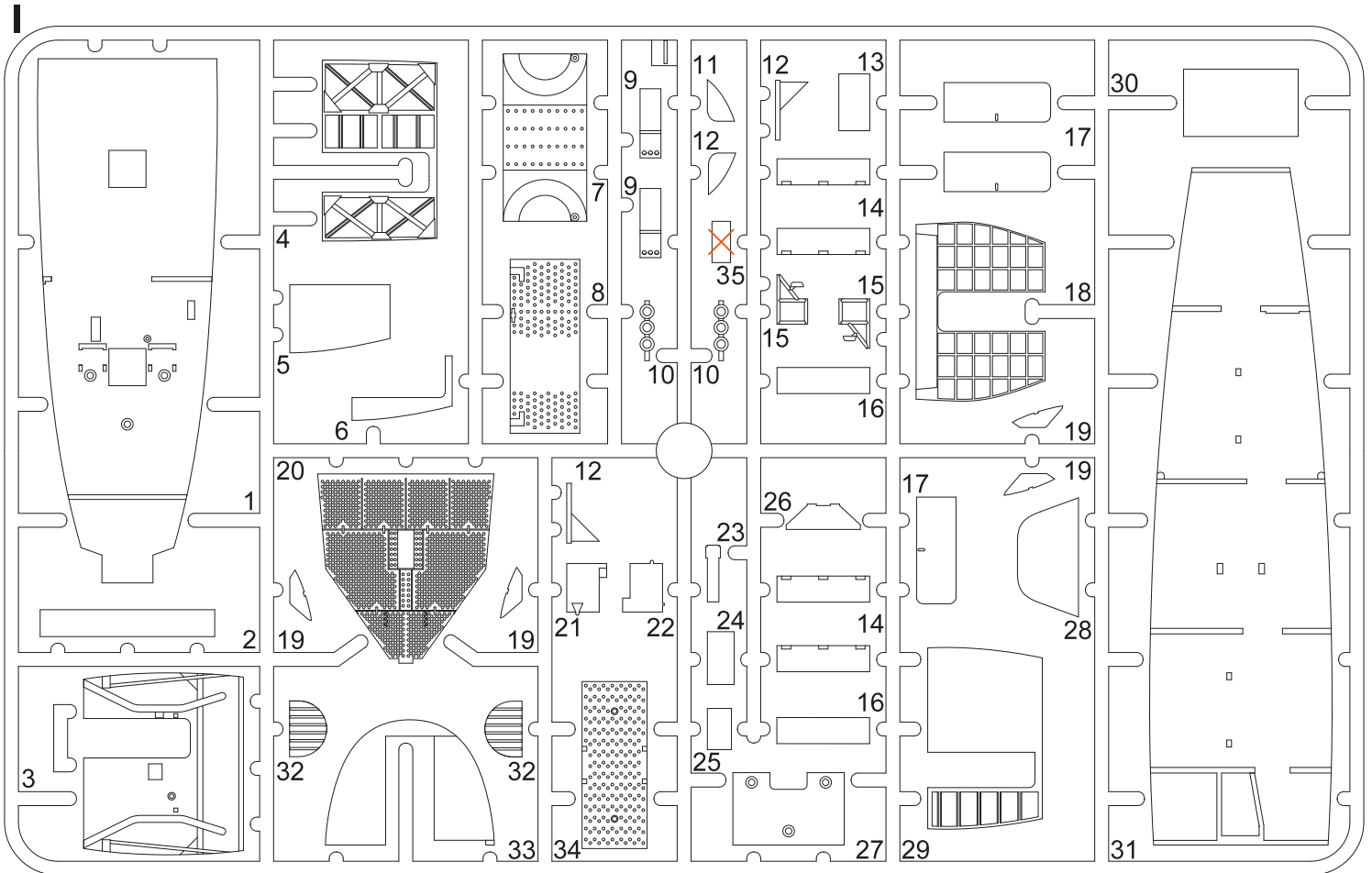

Tento díl nepoužít  Do not use this part

Barvy GUNZE/ GUNZE Colour No.

A Černá/ Black	H12/ C33	H Žlutá/ Yellow	H4/ C4
B Barva pneu/ Tire Black	H77/ C137	I Barva plátna/ Tan	H27/ C44
C Tmavý kov/ Dark Iron	H28/ C78	J Bílá/ White	H28/ C78
D Hliník/ Aluminium	H8/ C8	K Dřevo/ Wood	H37/ C43
E Inter. šedozelená/ Inter. Grey Green	C364	L Opálený kov/ Burnt Iron	H76/ C61
F Motorová šedá/ Engine Grey	H339/ C339	M Barva kůže/ Red Brown	H17/ C29
G Červená/ Red	H43/ C100		

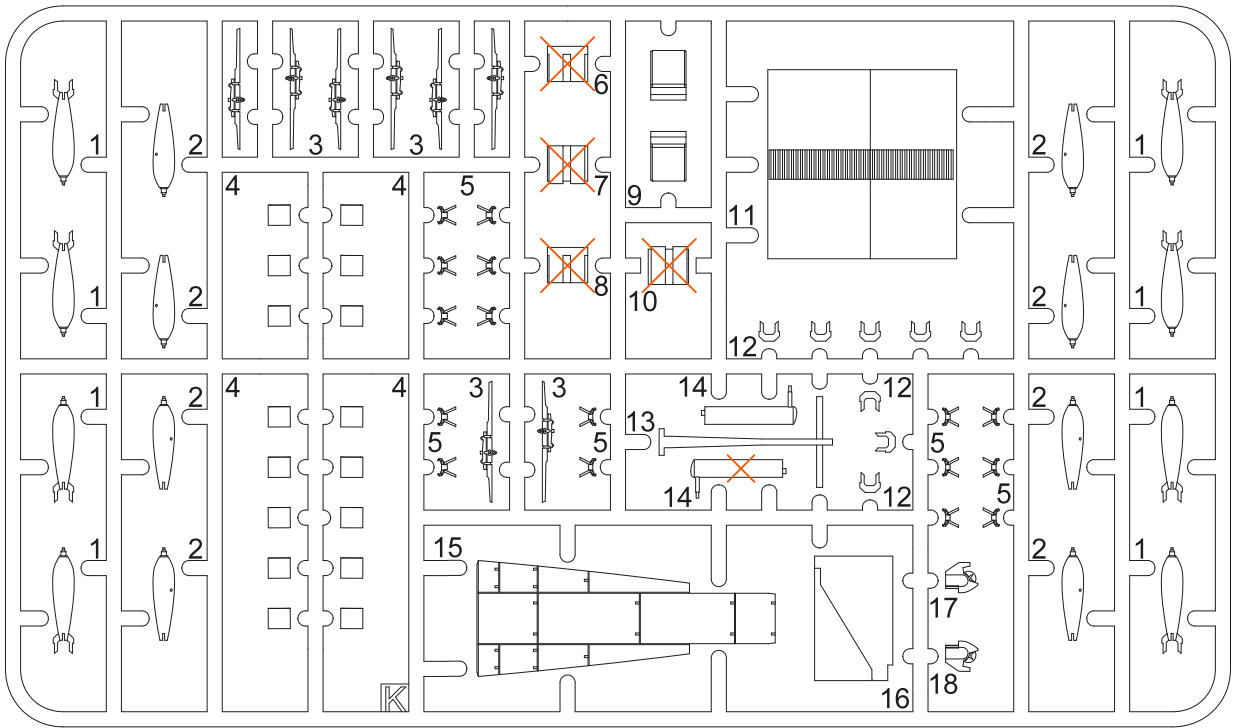
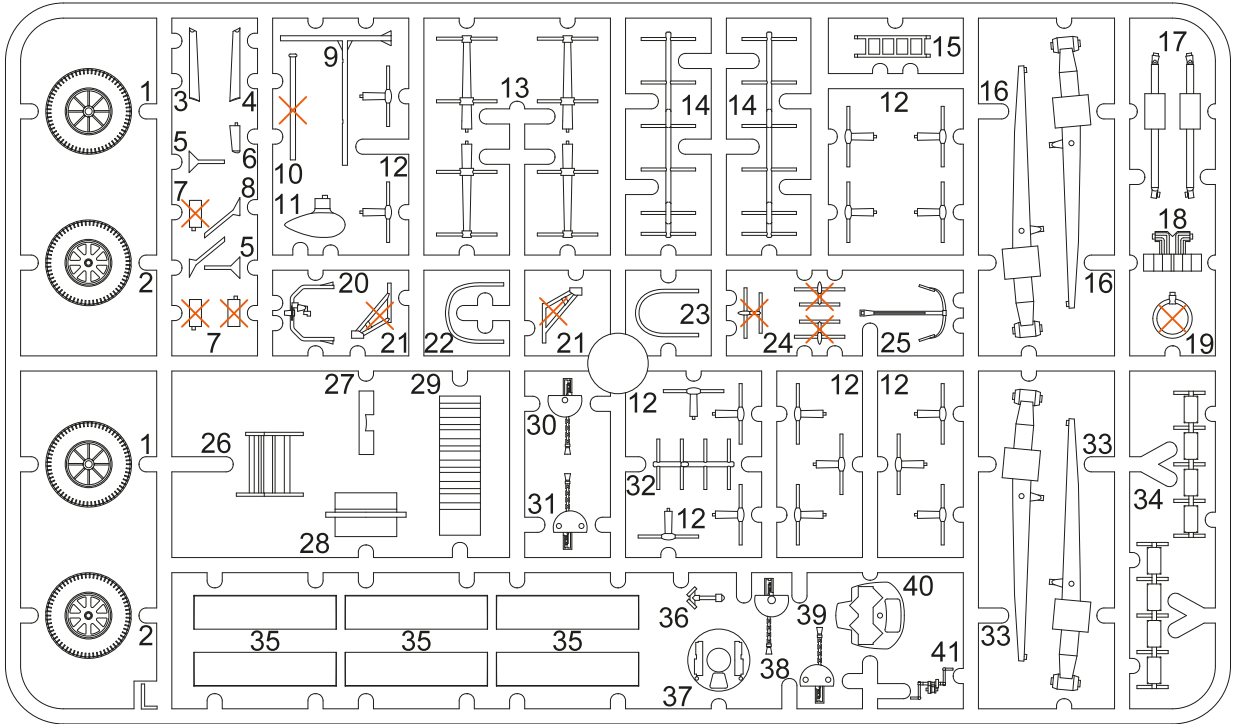
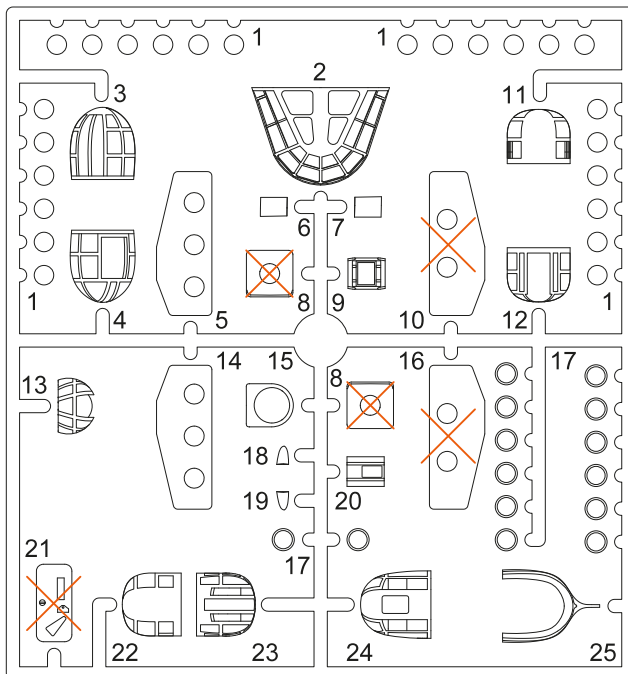
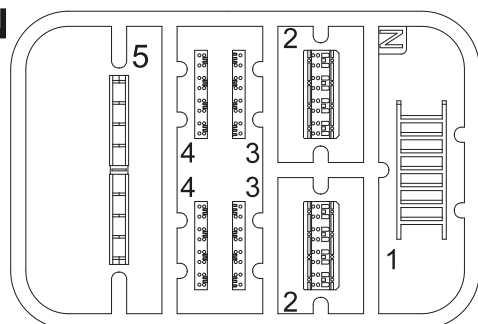
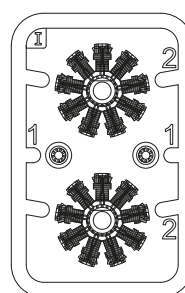
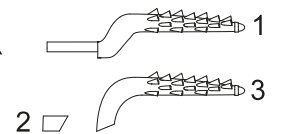
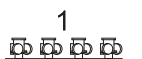
K**L****CP
(Clear
Parts)****N****2x I****PUR****PRINT (P)**

STEP 1

Assembly

STEP 2

STEP 3

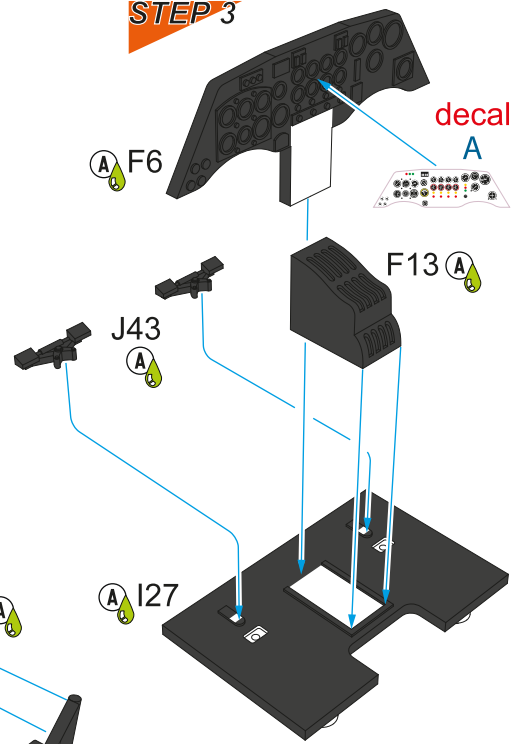
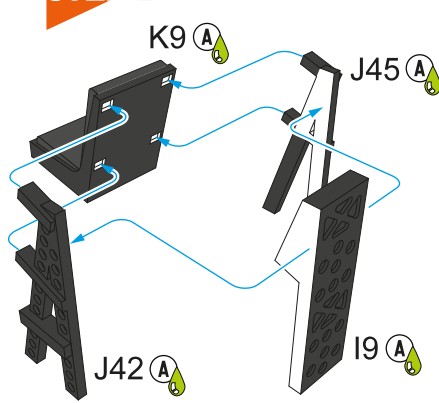
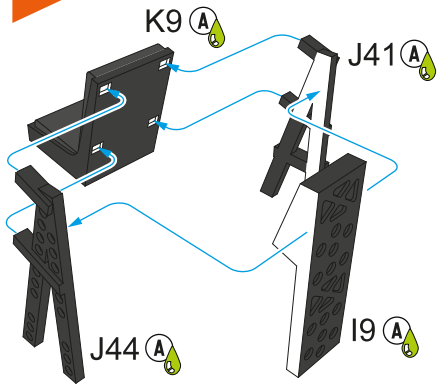

STEP 4

STEP 5

STEP 7

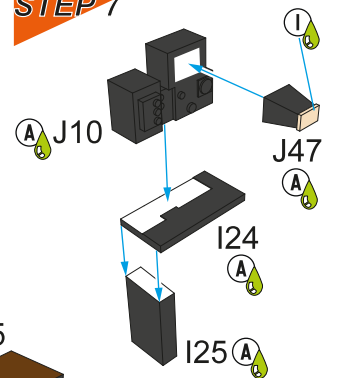
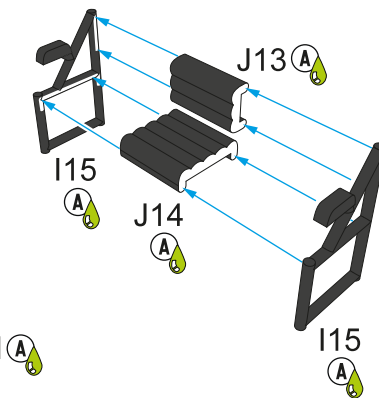
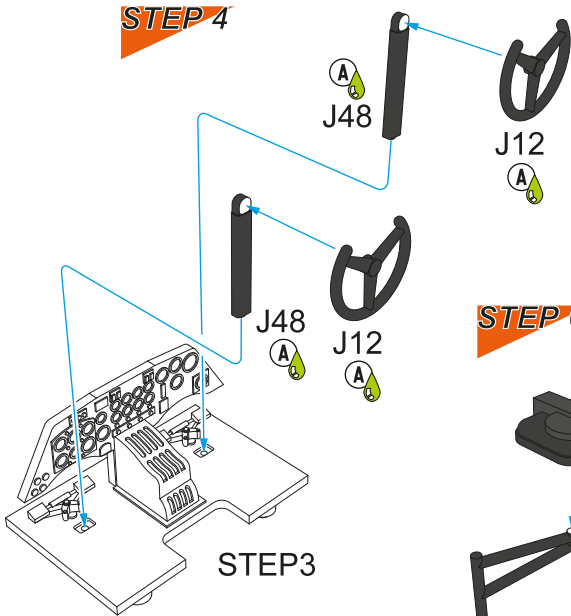

STEP 6

STEP 8

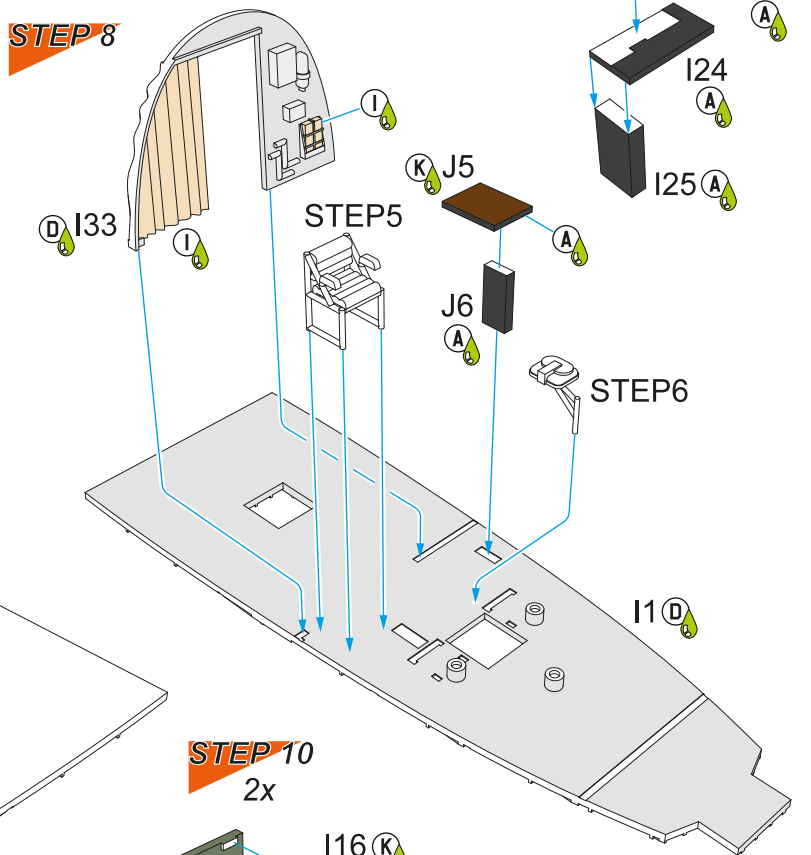
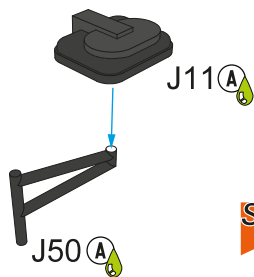

STEP 9

STEP 10
2x

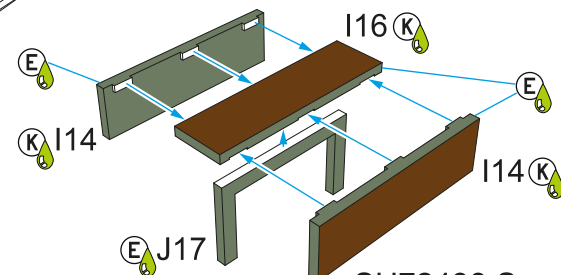
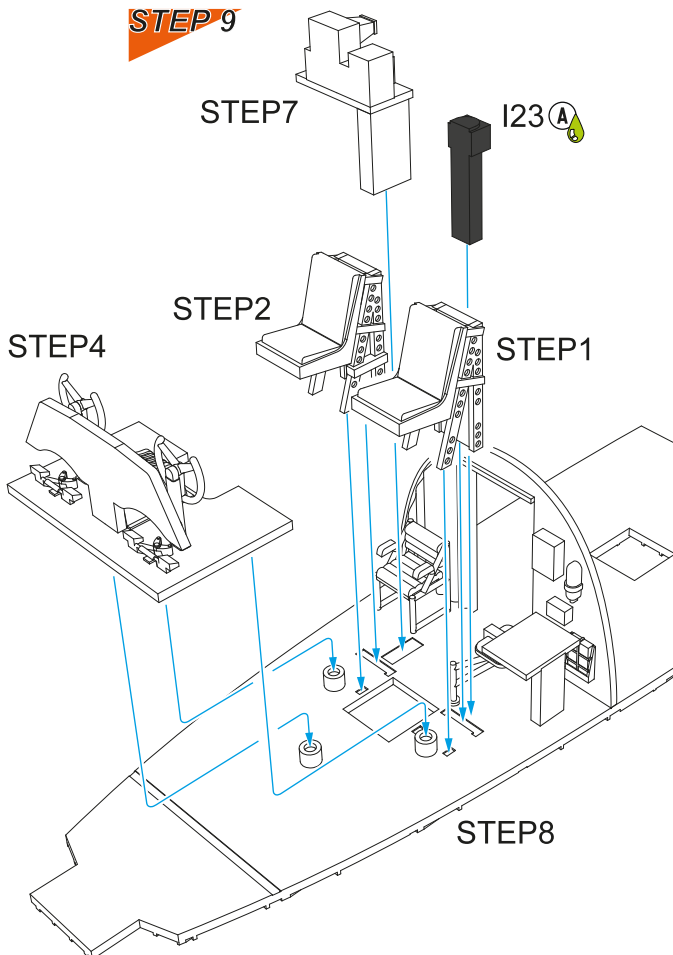

STEP 11 interior decals

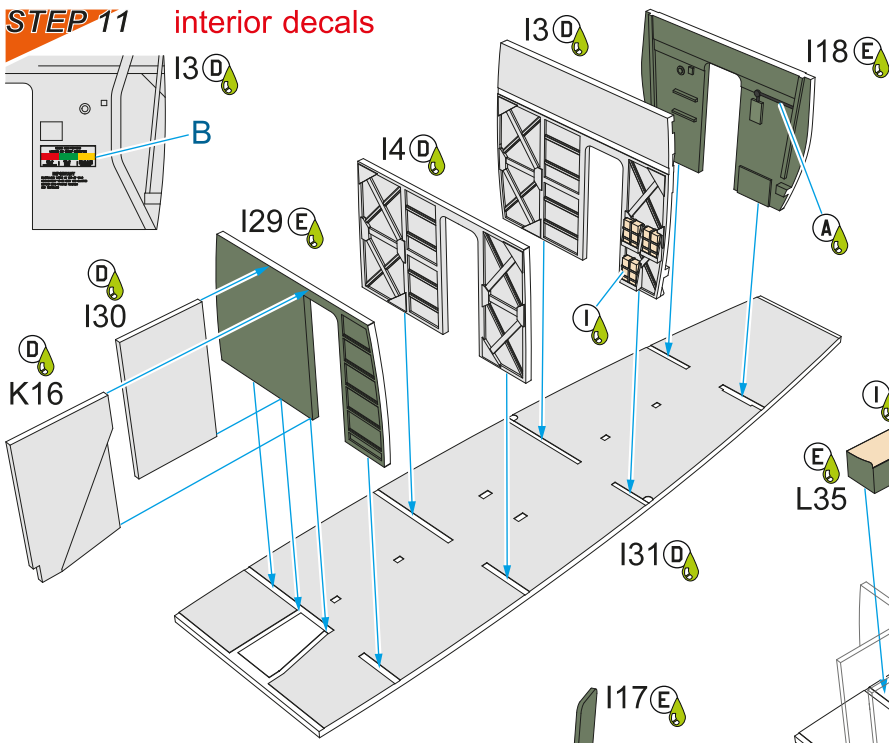

STEP 12

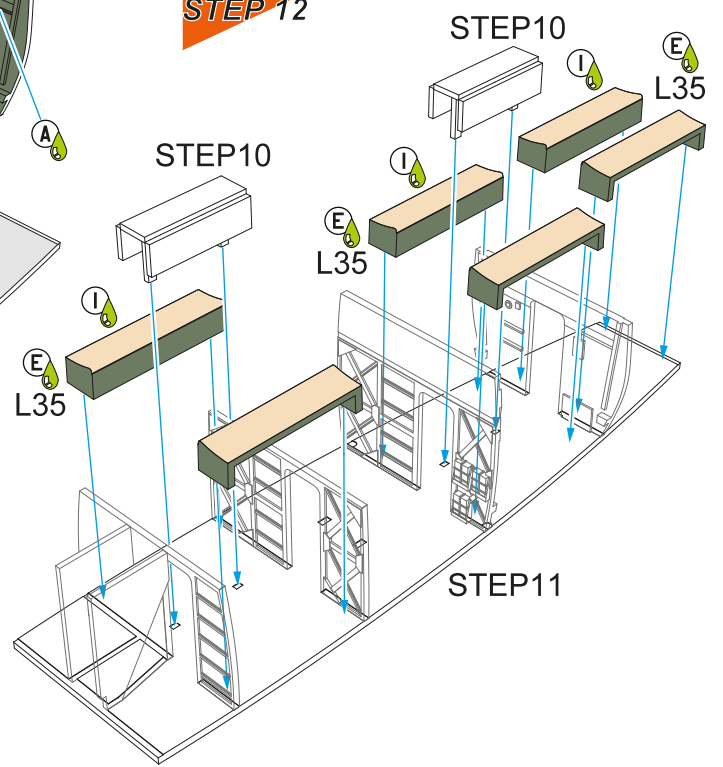

STEP 13

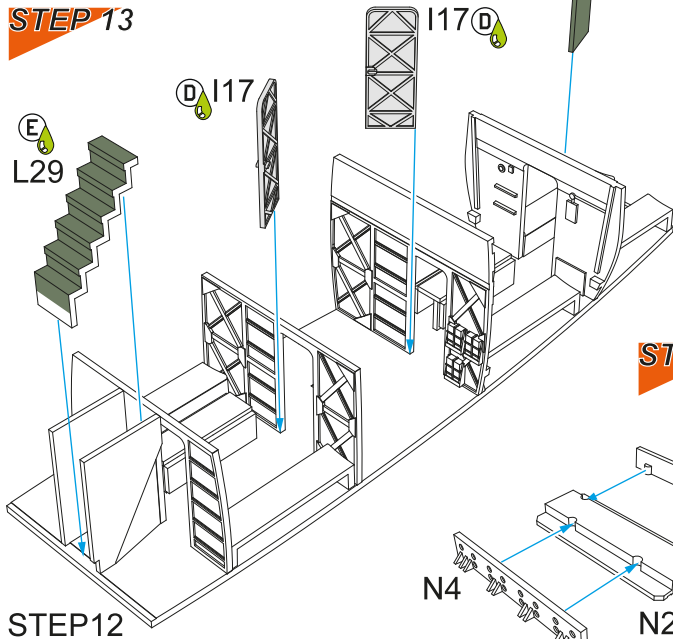

STEP 14
2x

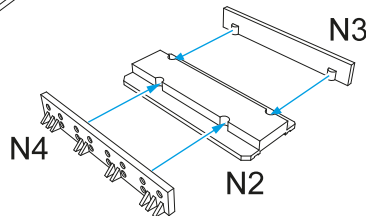

STEP 15

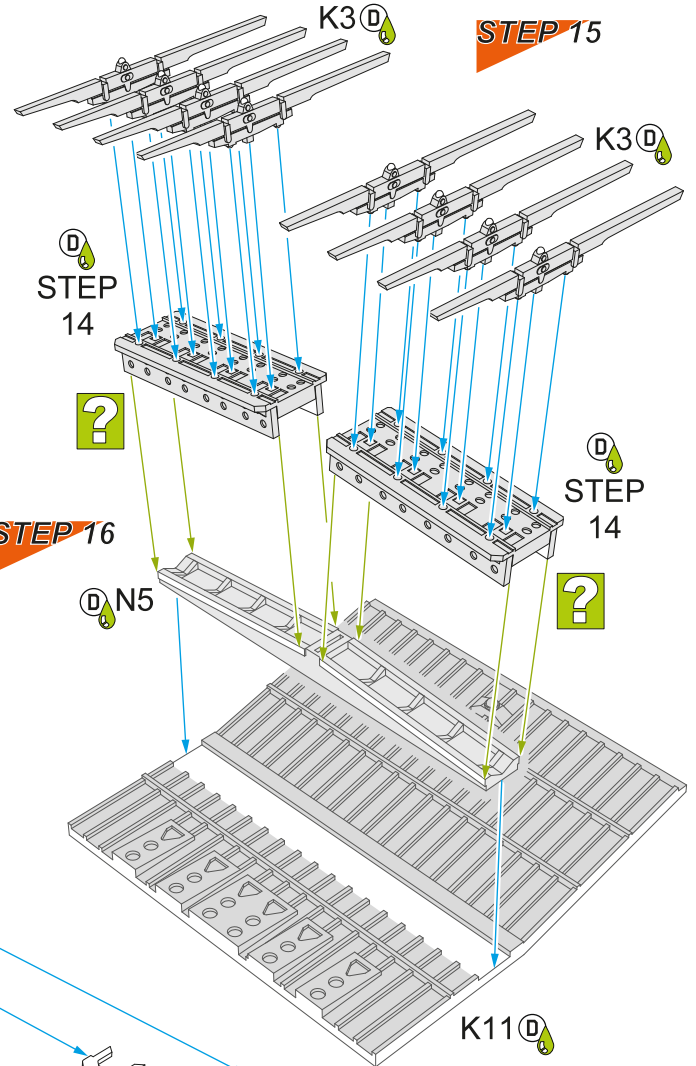

STEP 16

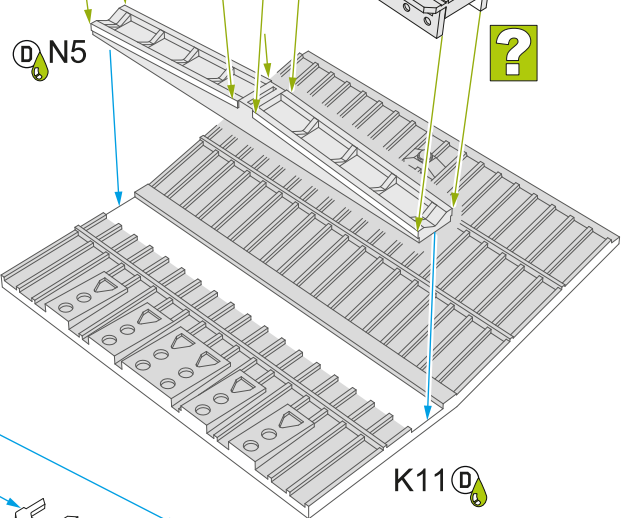

STEP 18
8x

See page 15

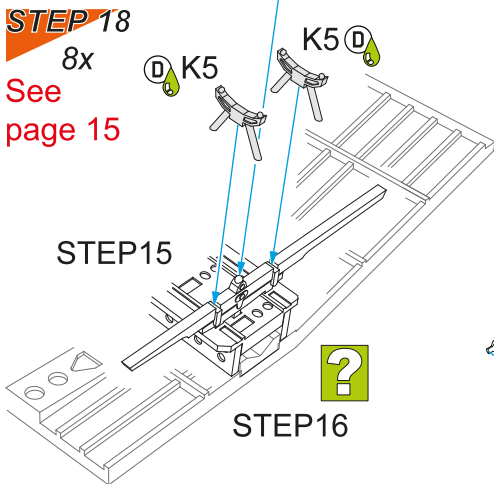

STEP 17
8x

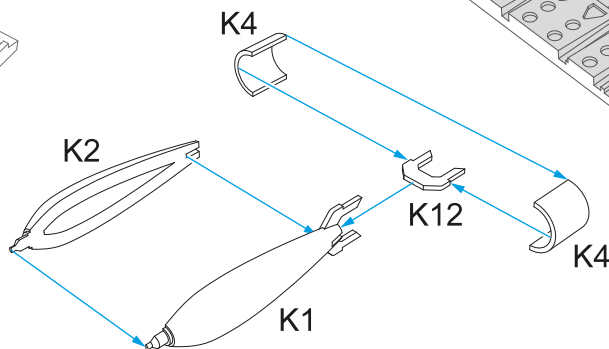

STEP 20

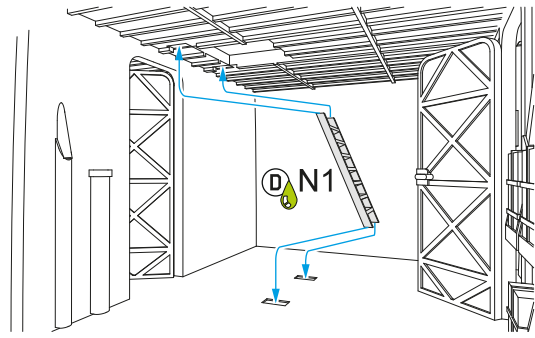

STEP19

STEP 19

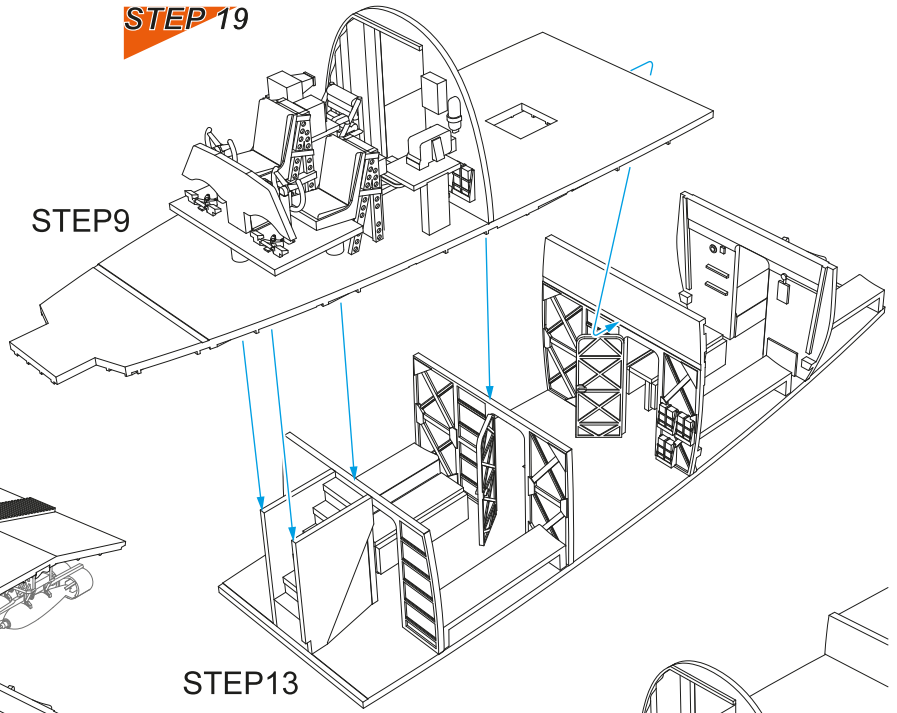

STEP9

STEP 16



STEP 18

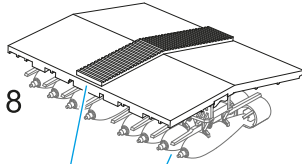

STEP 21

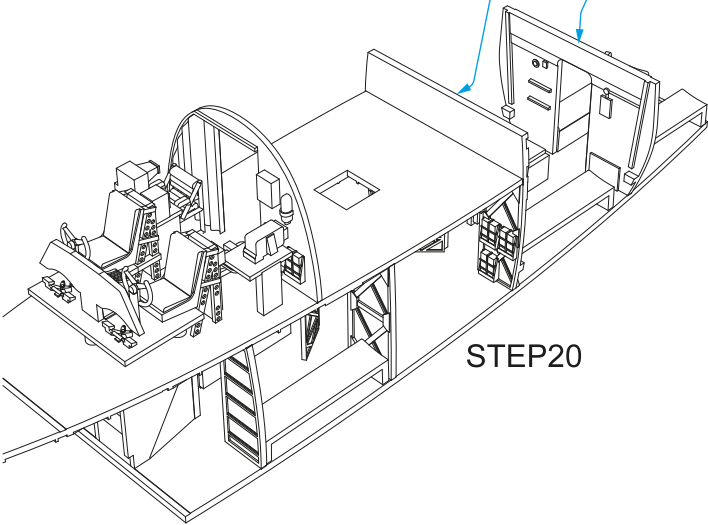

STEP20

STEP13

STEP 22

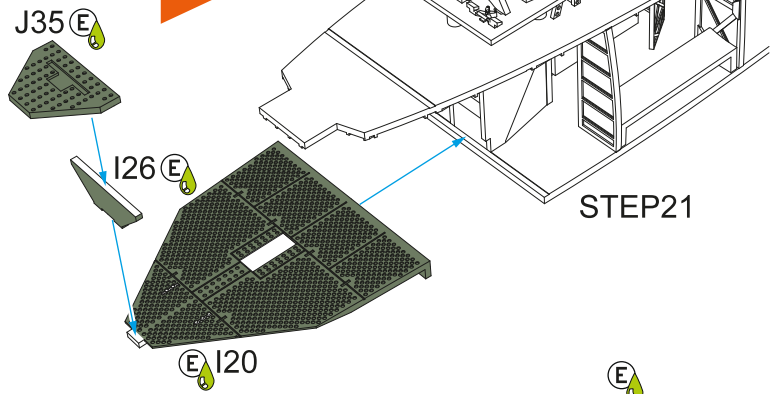

STEP21

STEP 23

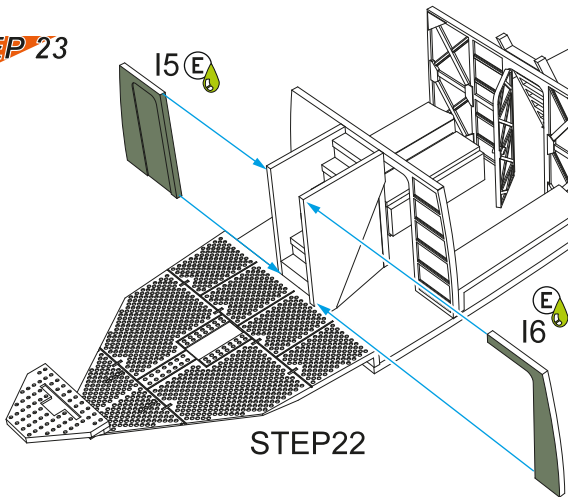

STEP22

STEP 24

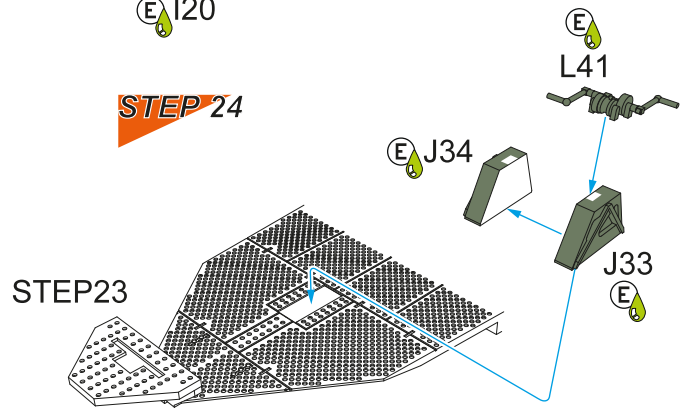

STEP23

STEP 25

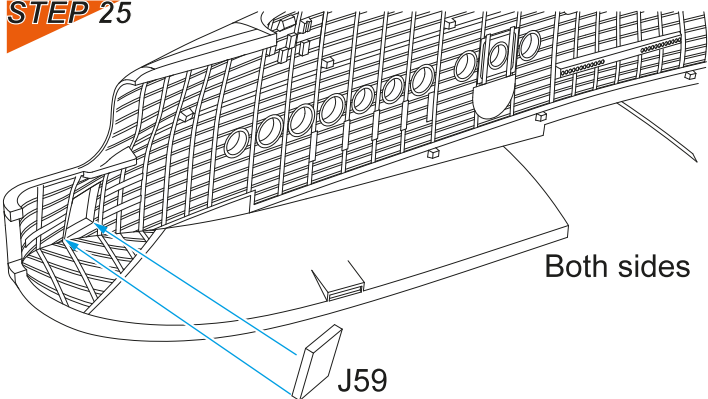

Both sides

STEP 26

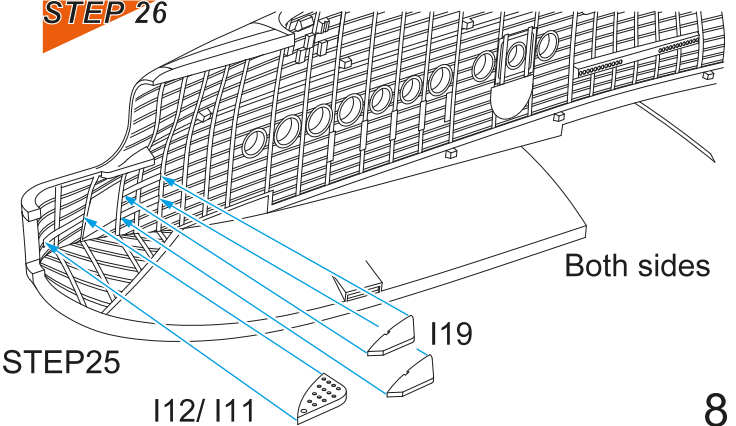

Both sides

STEP25

STEP 27

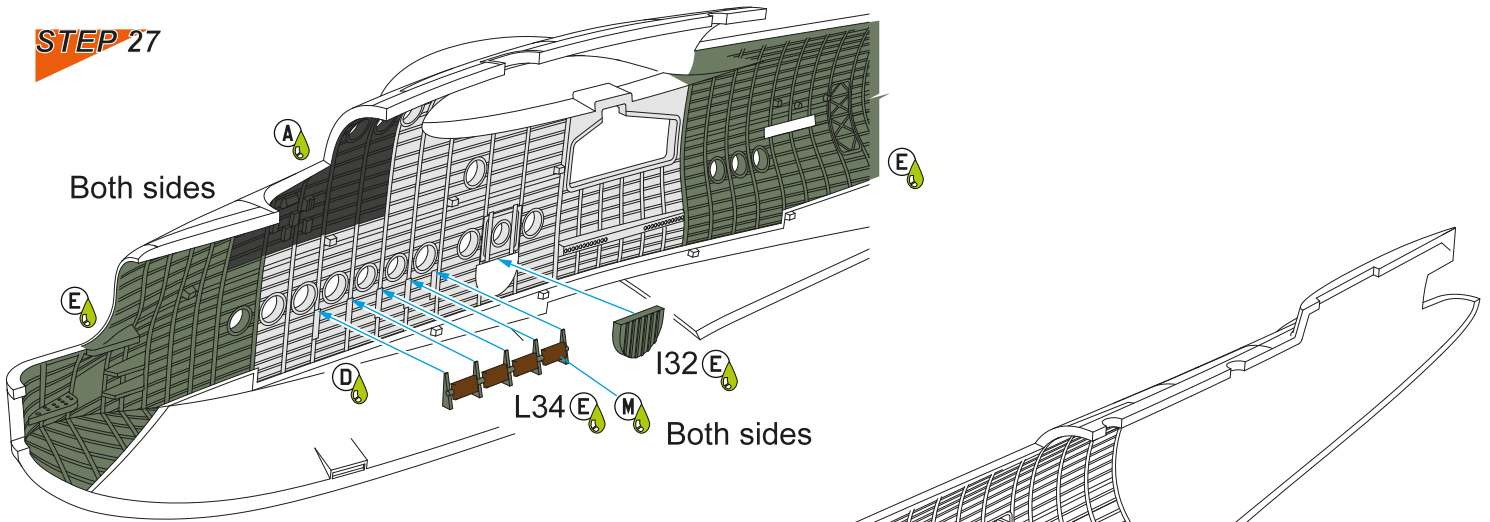

STEP26

STEP 28

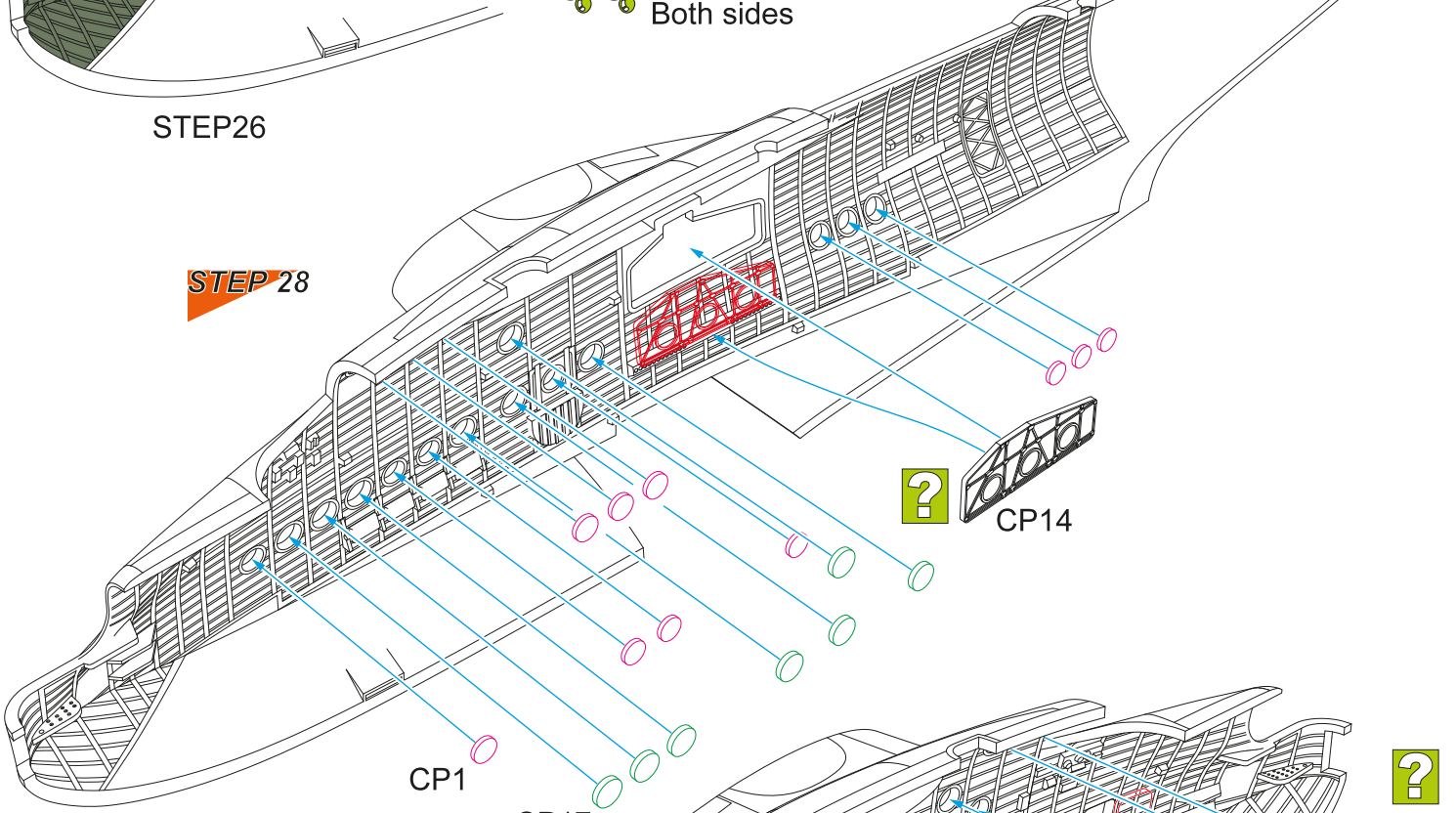

STEP27

STEP 29

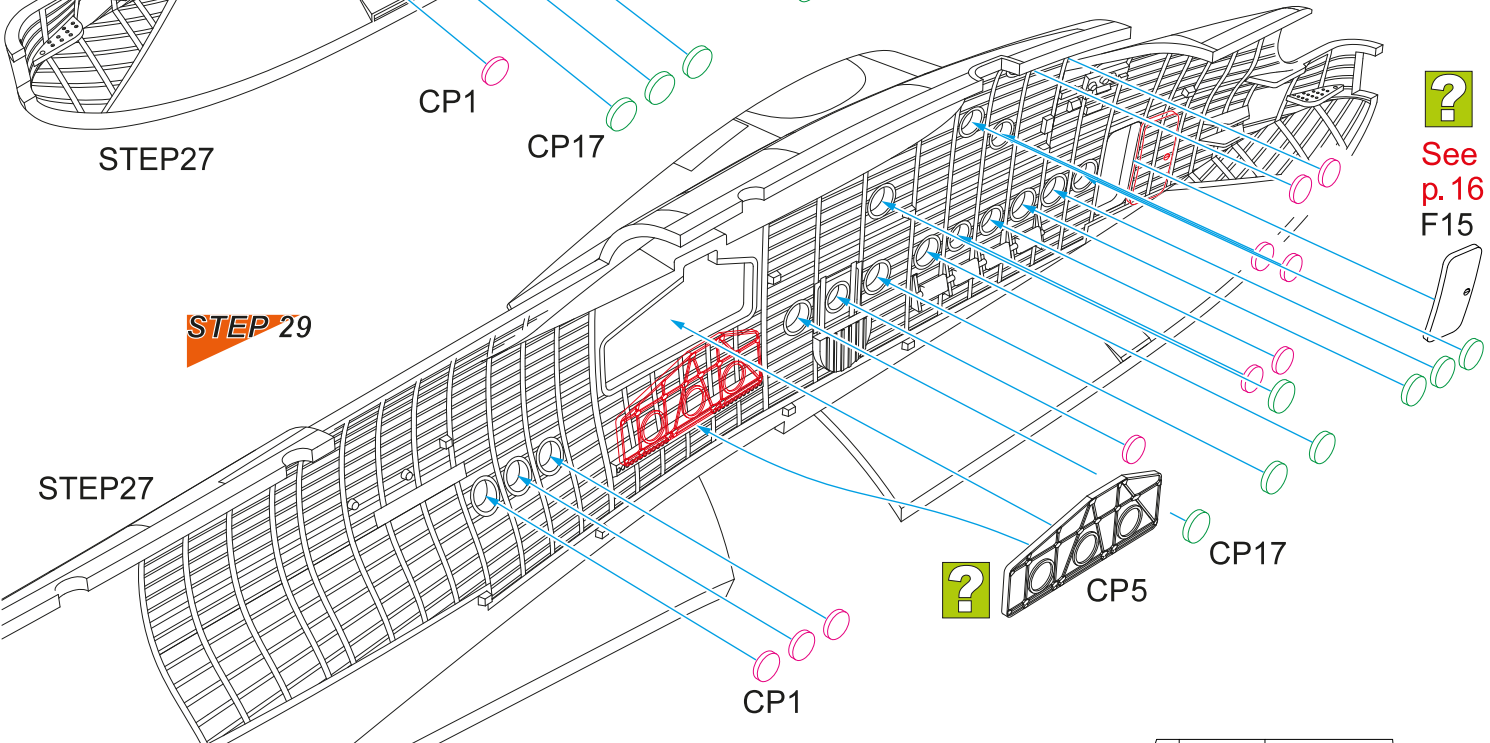

STEP27

STEP 30

Scheme A, B, D

Both sides
8x Ø0.6mm

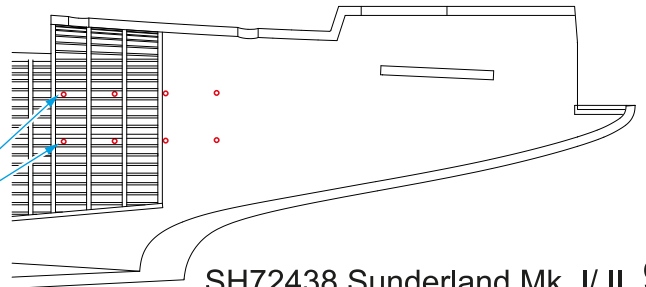

?
See p.16
F15

STEP 31

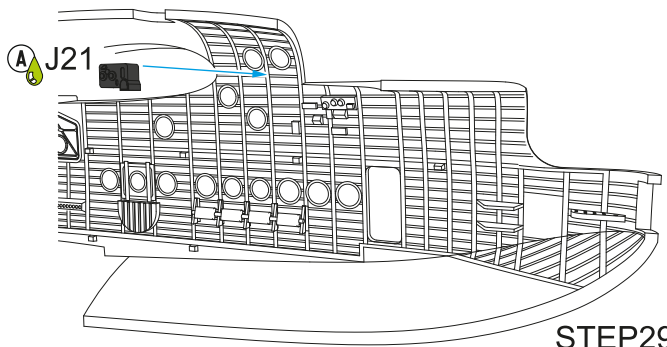

STEP29/ 30

STEP 32

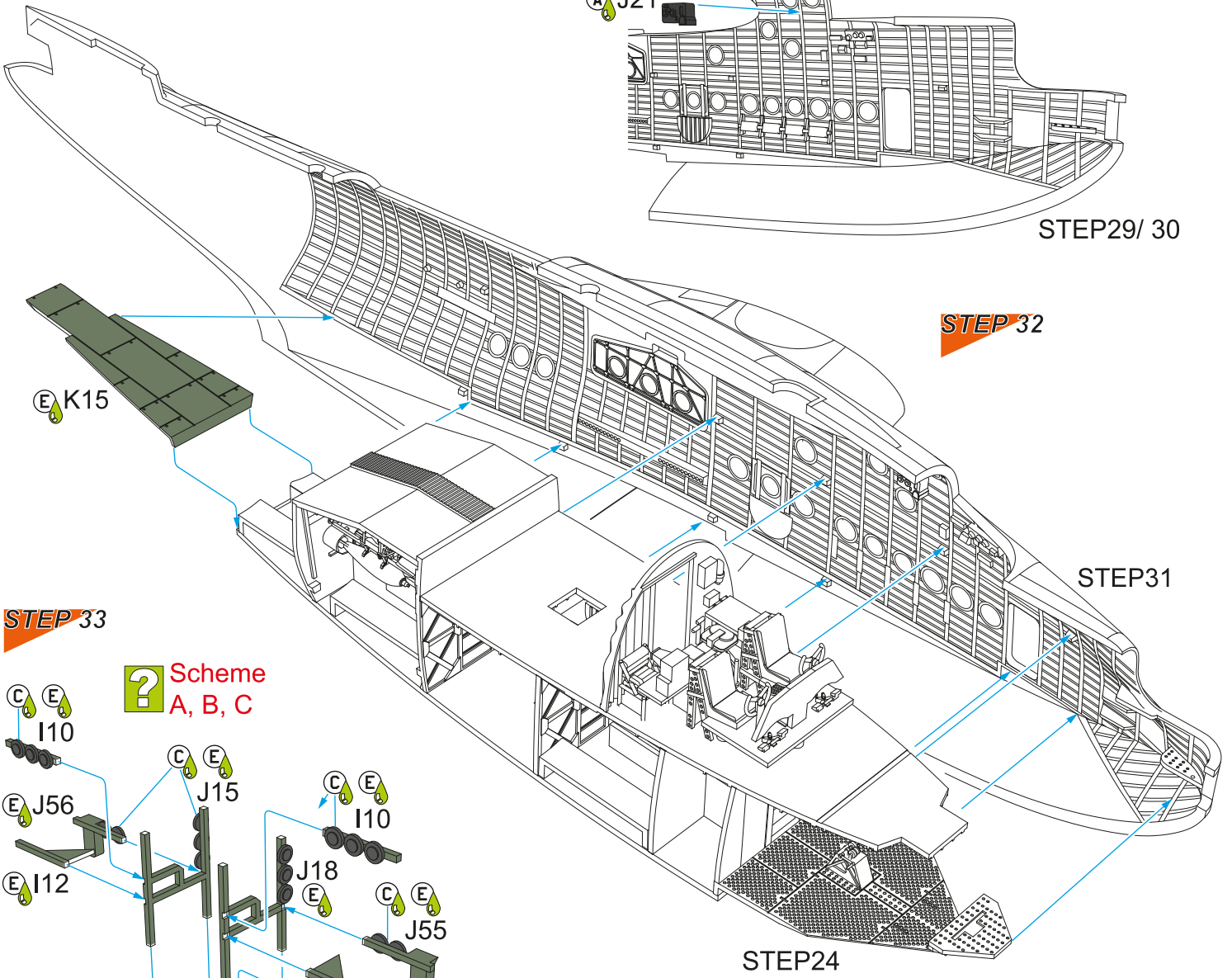

STEP 33

? Scheme A, B, C

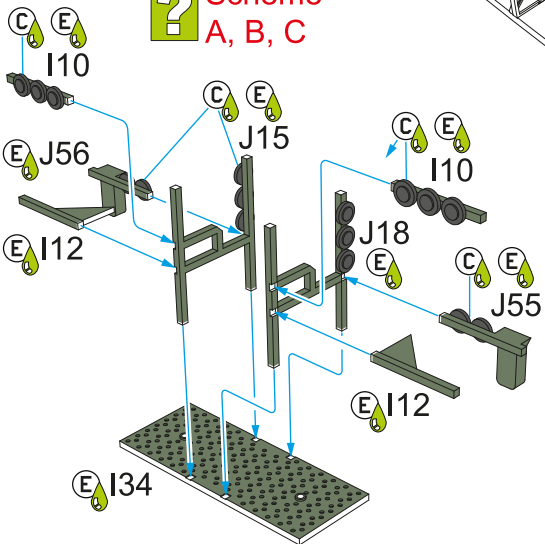

STEP32

STEP 34

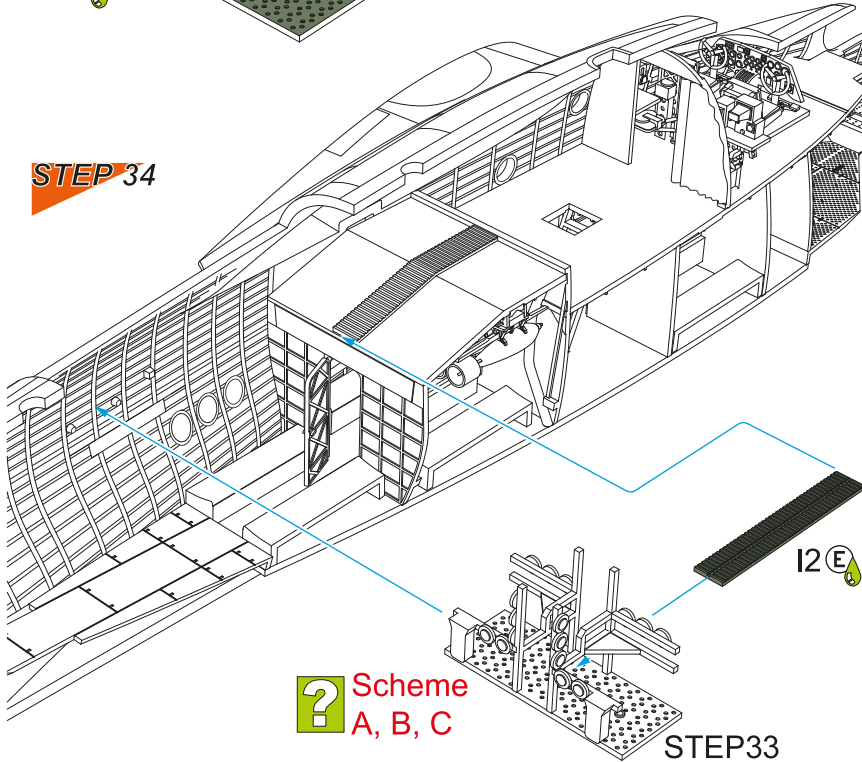

Interior view

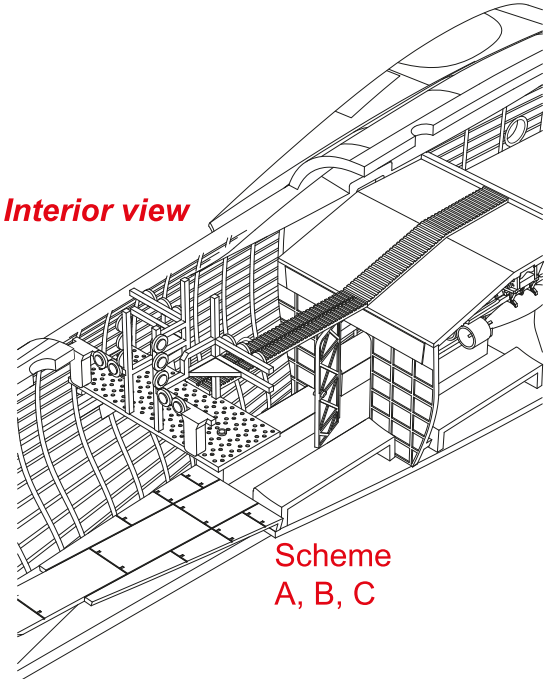

STEP 35

? **Scheme D**

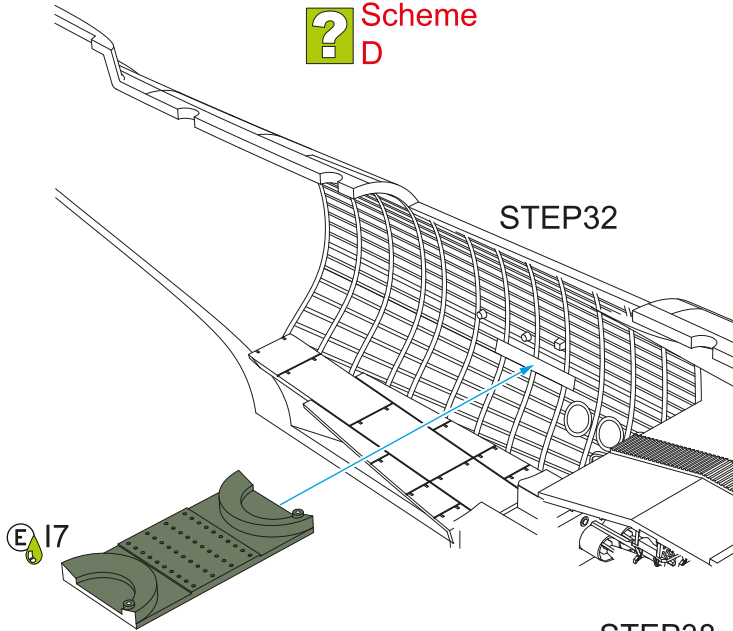

STEP 36

? **Scheme D**

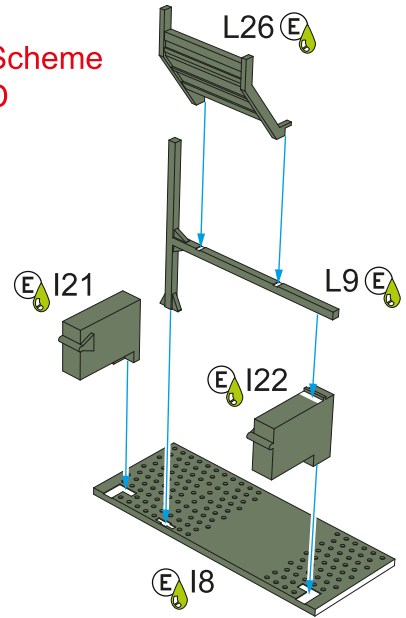

STEP38

STEP 37

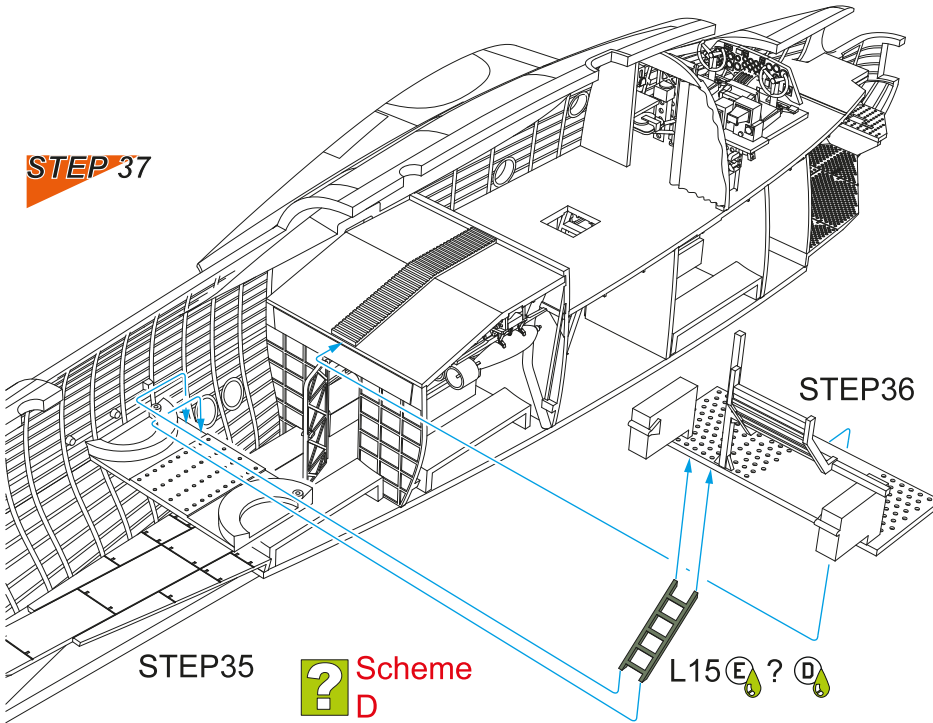

Interior view

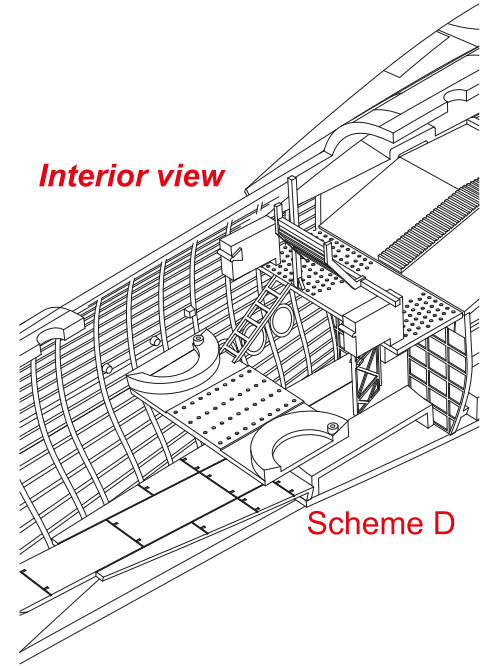

STEP 38

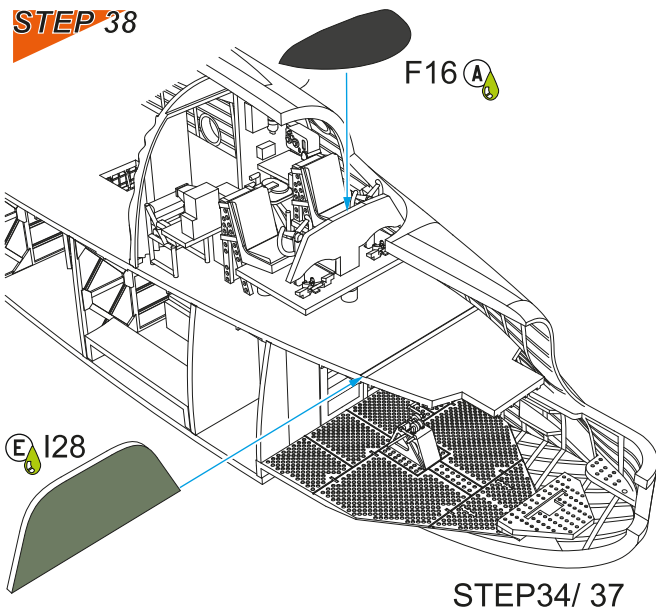

STEP 39

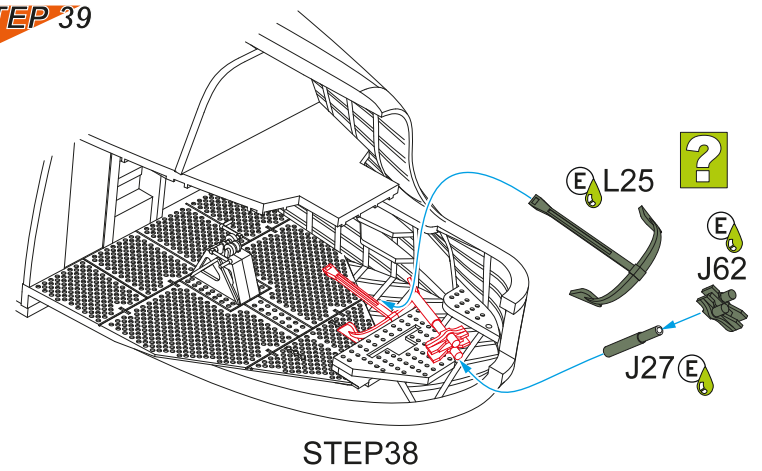

Interior view

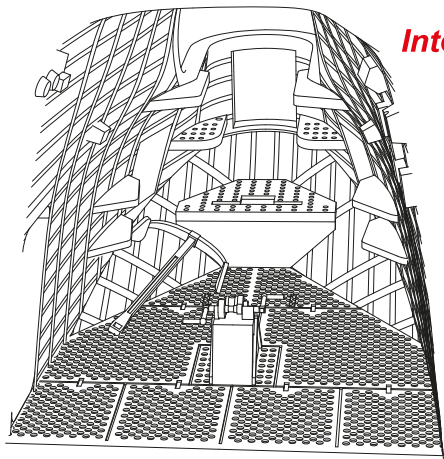

STEP40

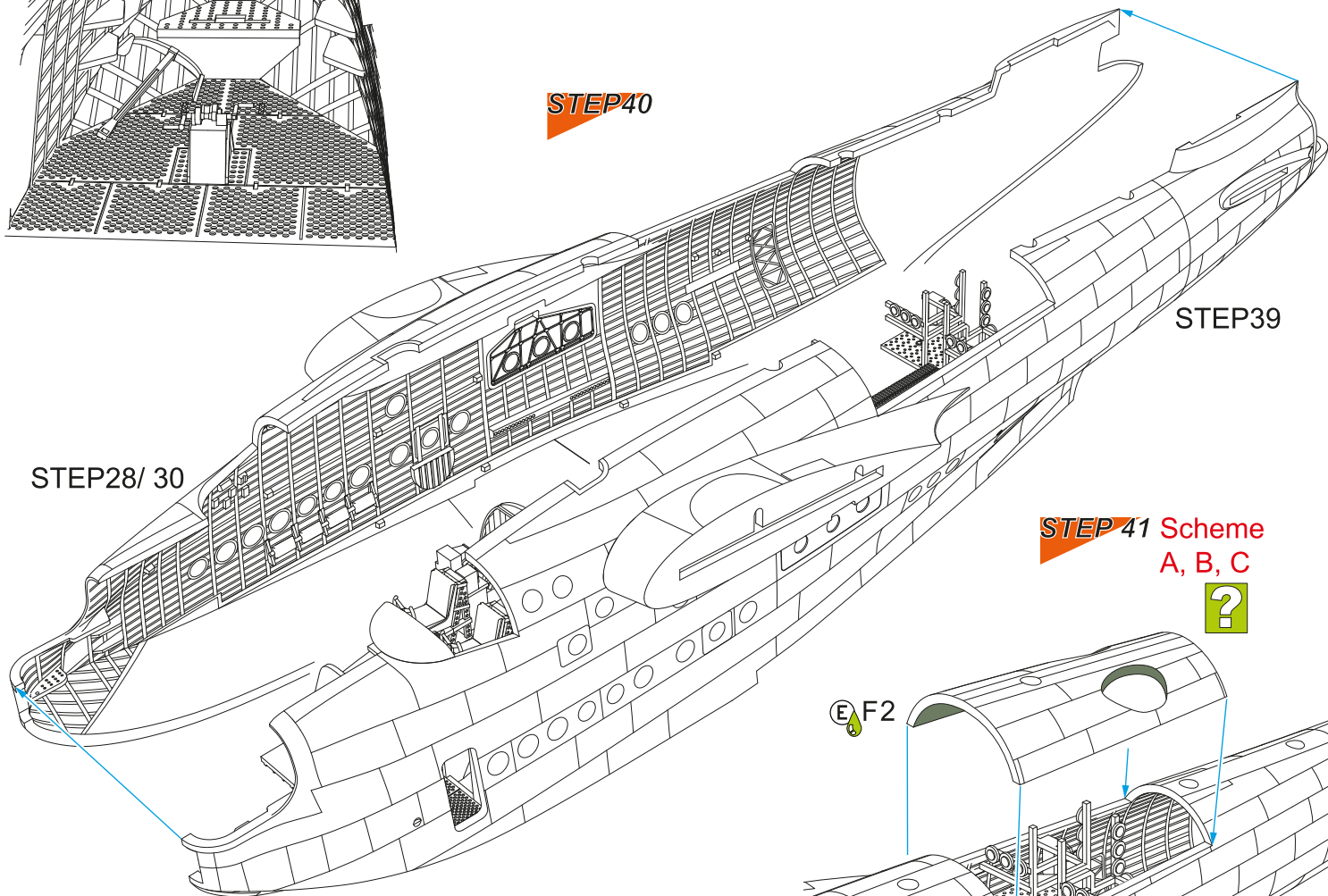

STEP 41 Scheme A, B, C



STEP 42 Scheme D

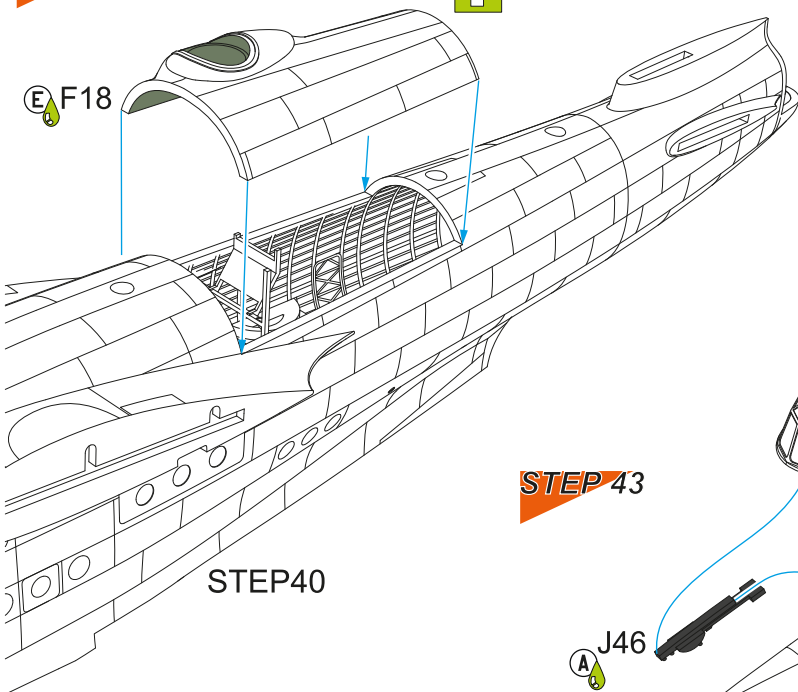

E F2

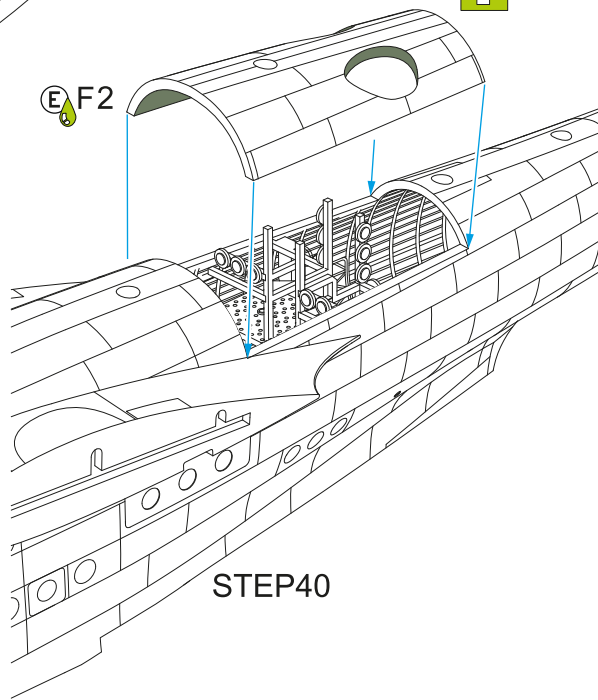

STEP40

CP2

STEP 43

J46

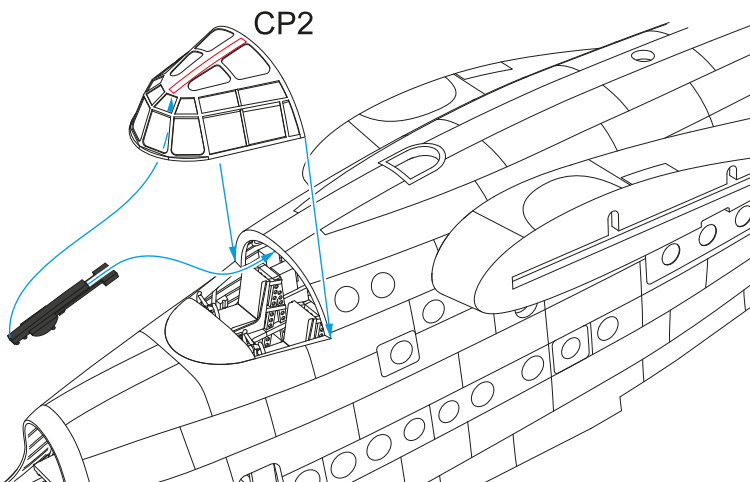

STEP40

STEP41/ 42

STEP 44

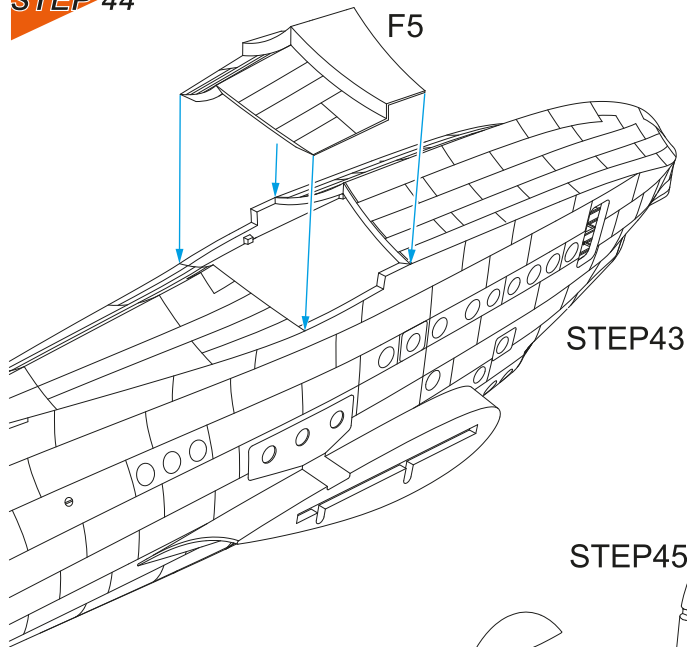

STEP 45

STEP 46

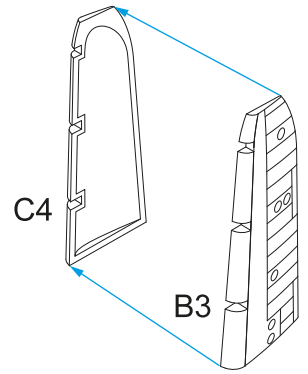
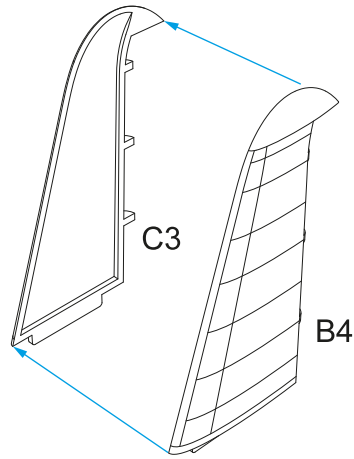

STEP 45

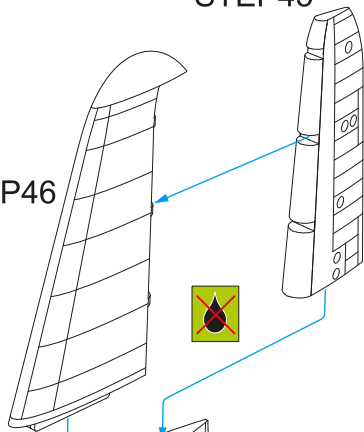

STEP 47

Test fit first,
glue in step 52!

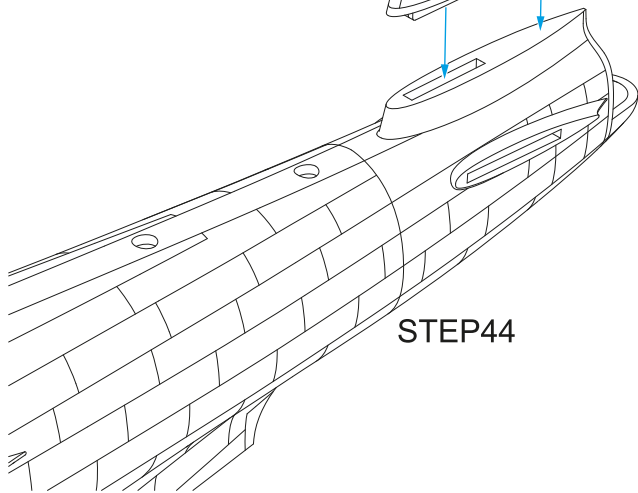

STEP 48

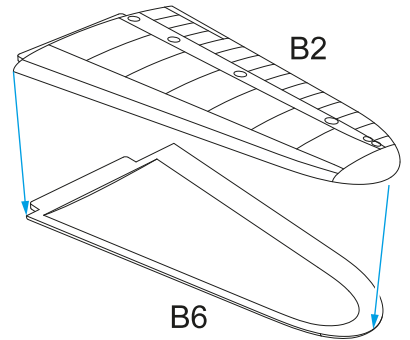

STEP 49

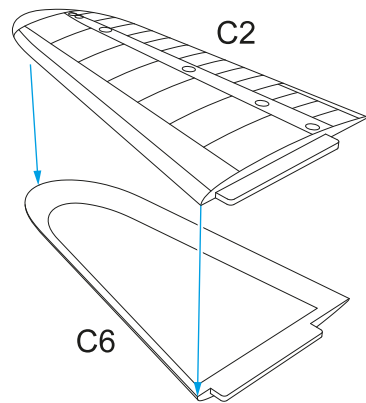

STEP 50

 $\varnothing 2.5\text{mm} - 3.0\text{mm}$
test fit with parts
PUR2 or PUR3

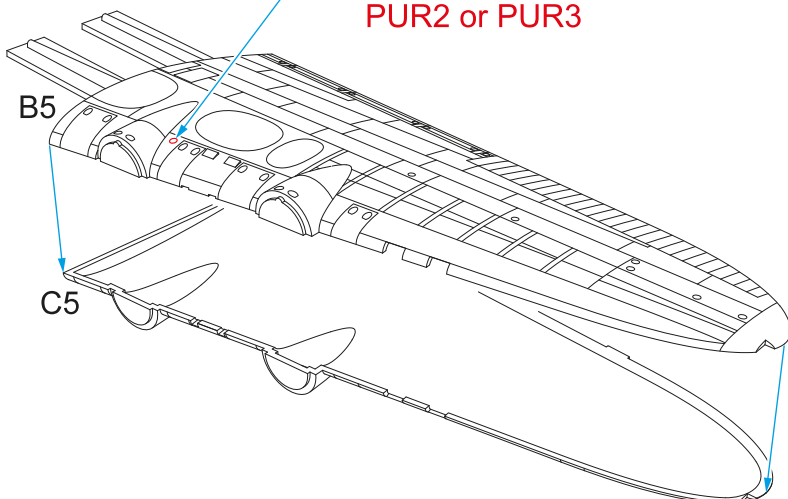

STEP 51

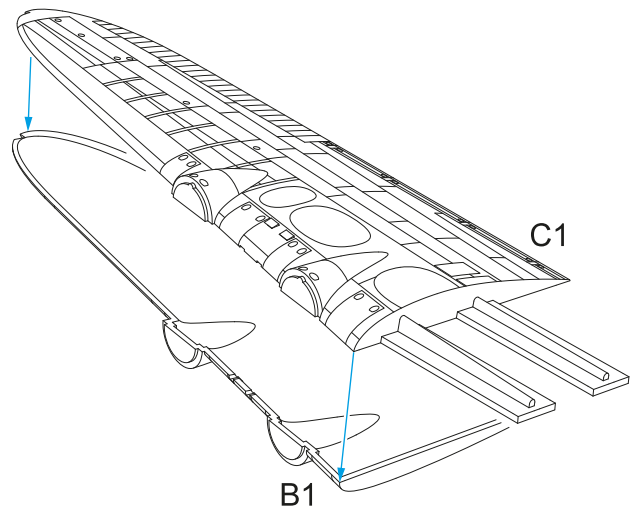

STEP 52

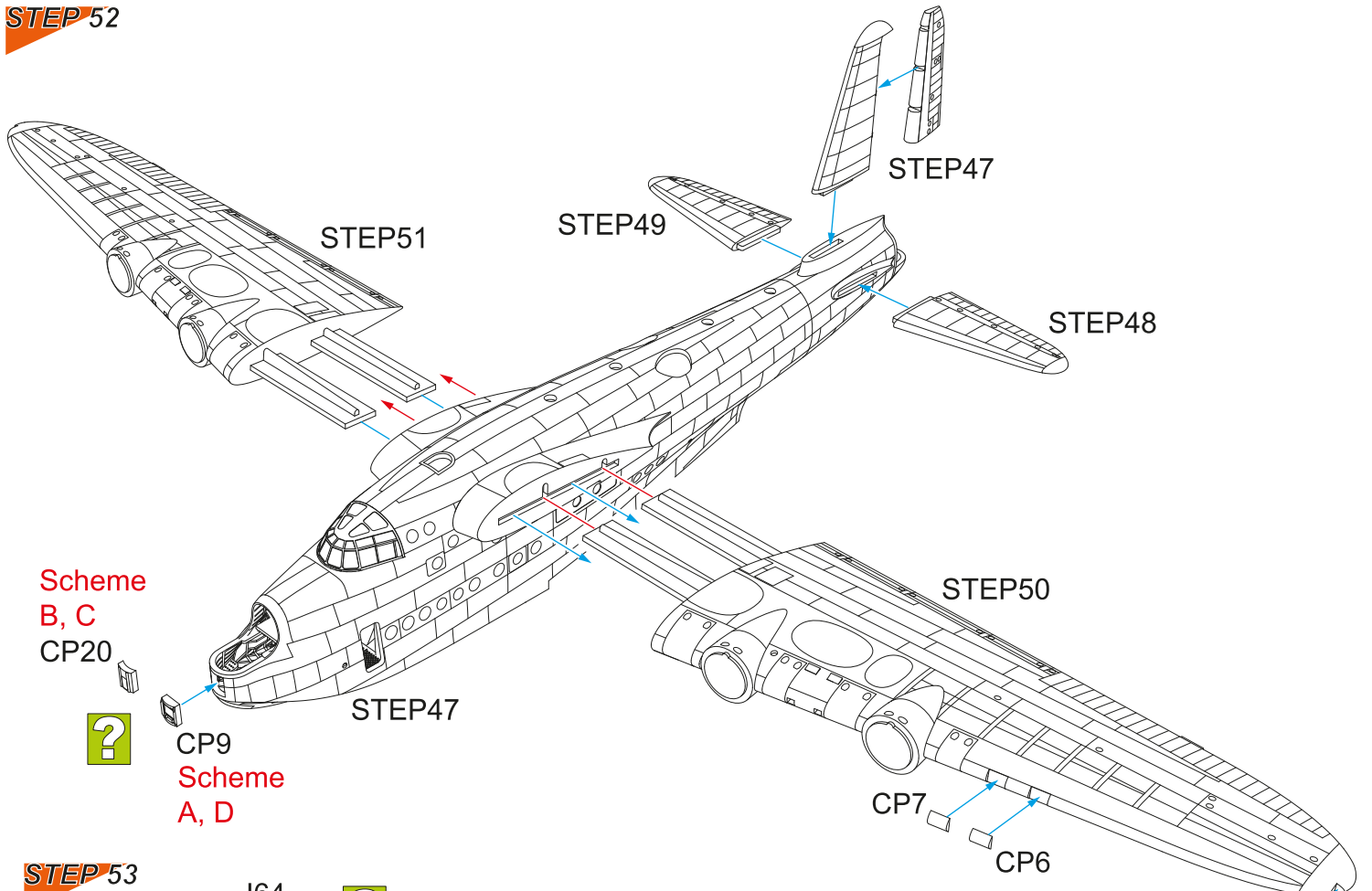

STEP 53

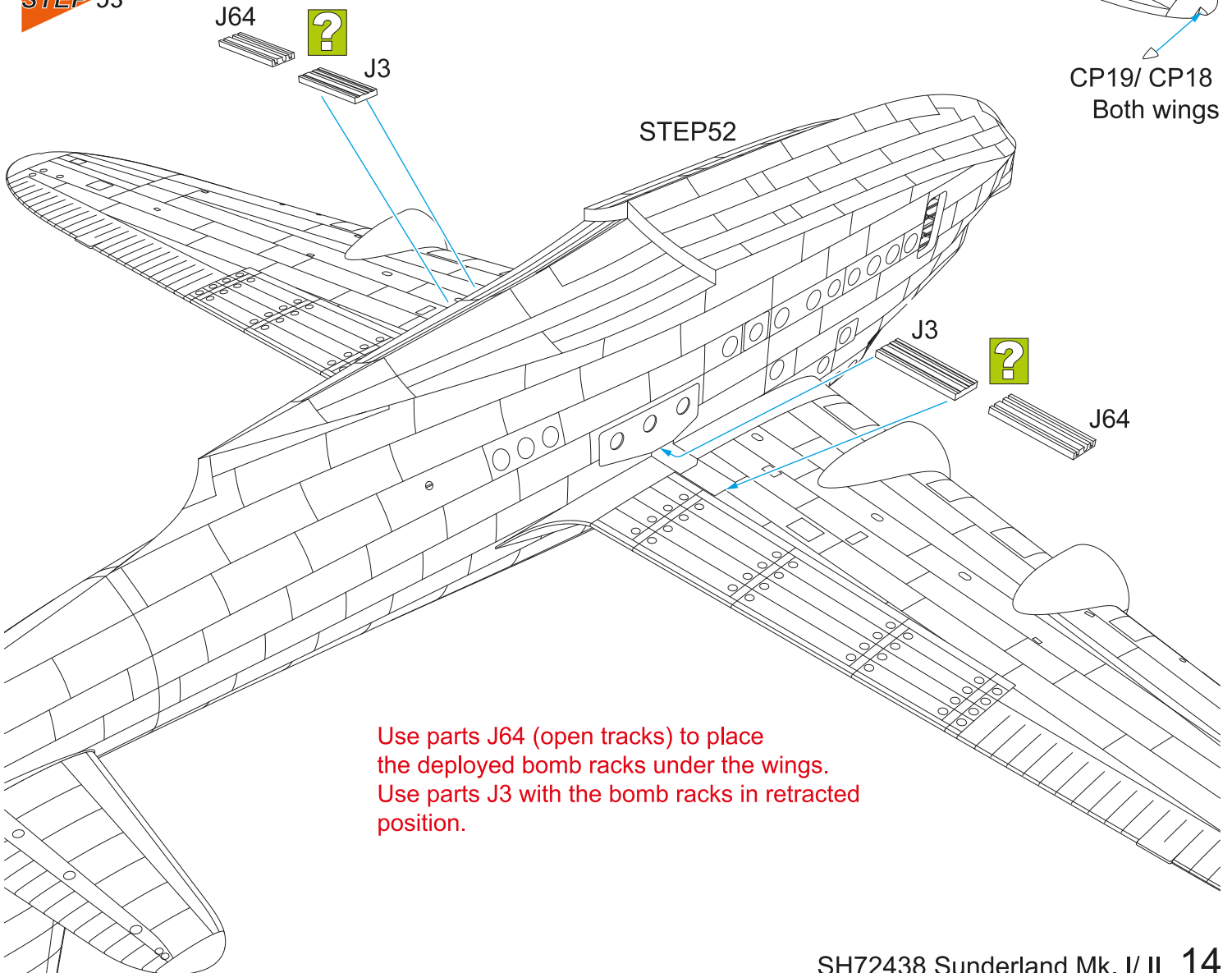

Use parts J64 (open tracks) to place the deployed bomb racks under the wings. Use parts J3 with the bomb racks in retracted position.

STEP 54

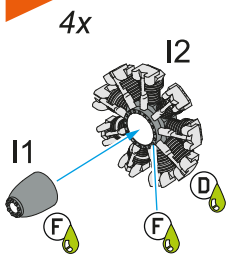

STEP 55

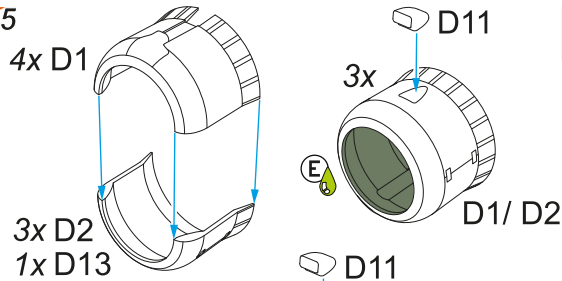

STEP 56

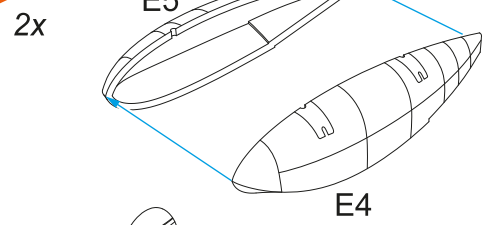

STEP 57

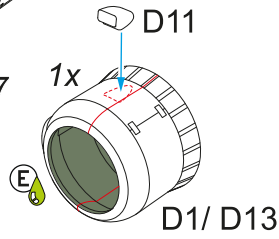

STEP 58

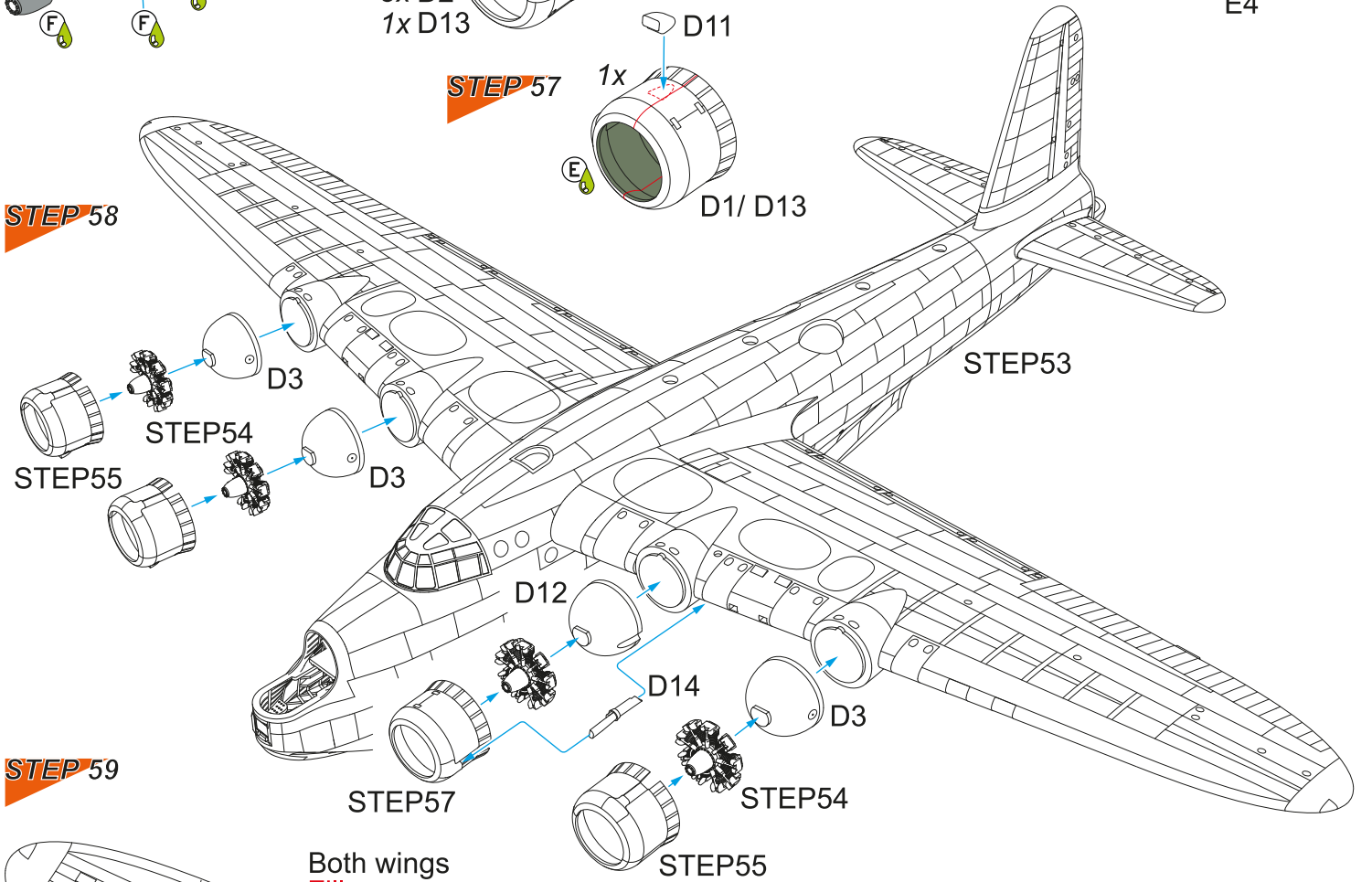

STEP 59

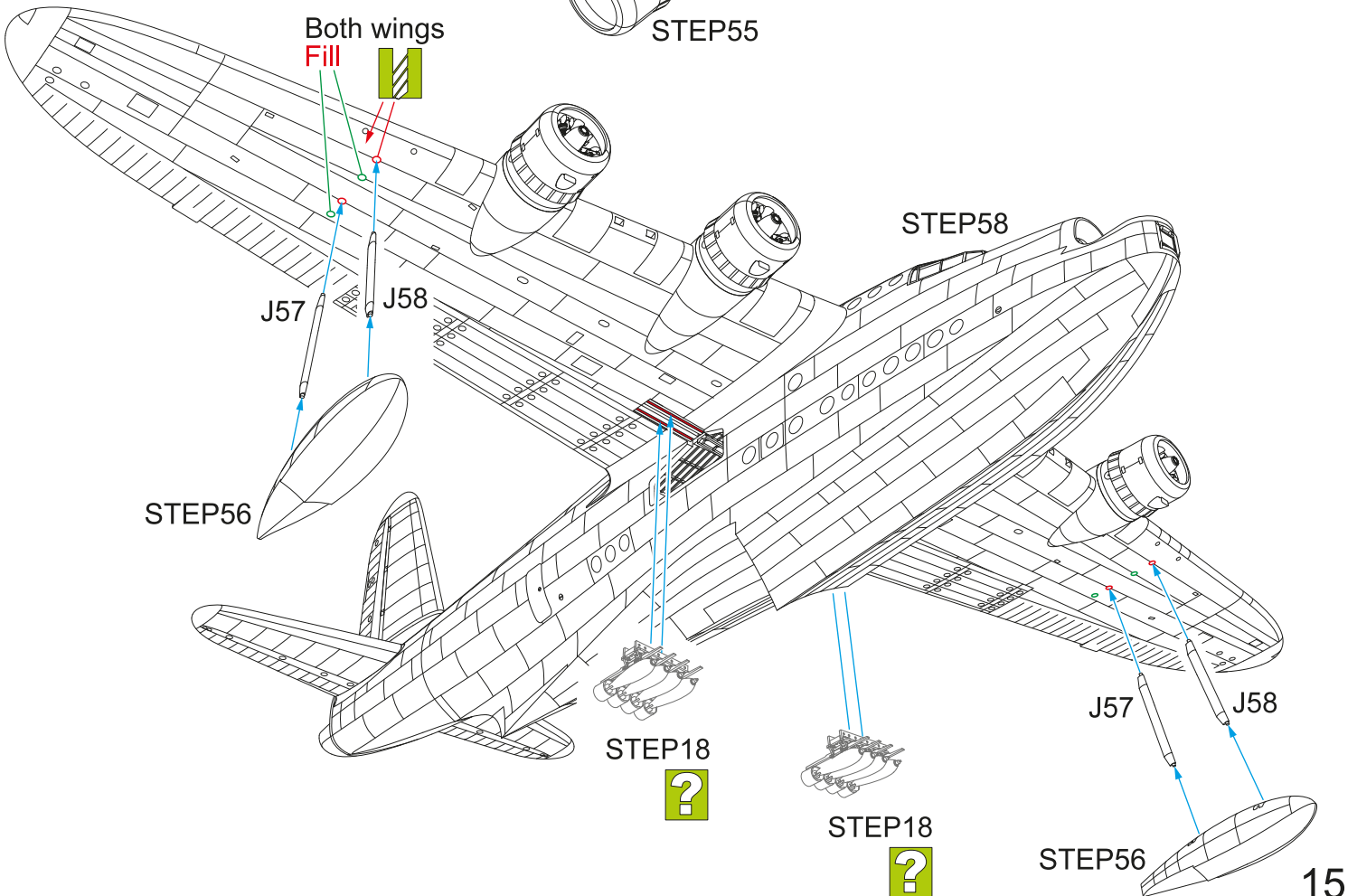

STEP 60

Scheme A, D

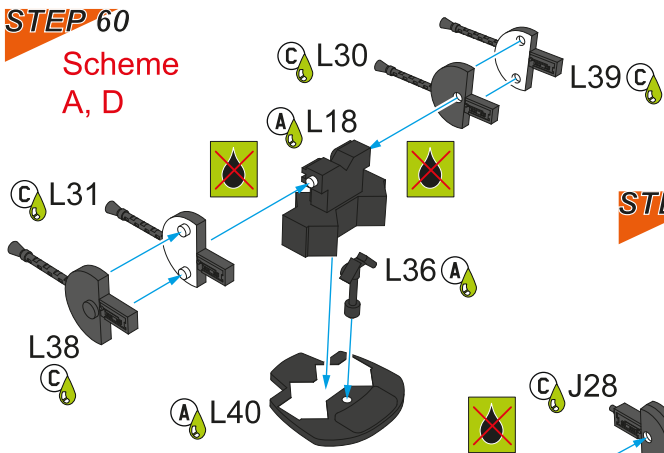

STEP 61

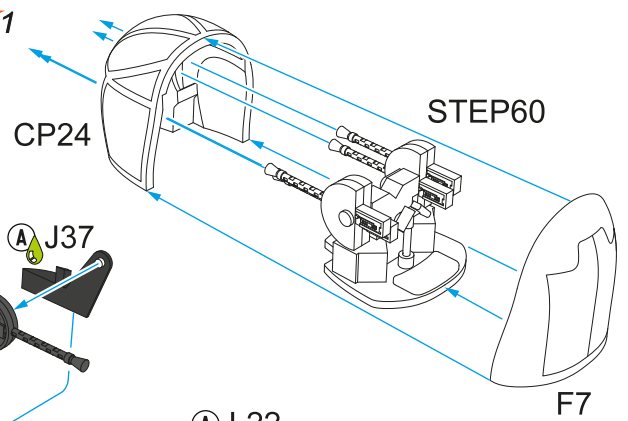

STEP 62

Scheme A, D

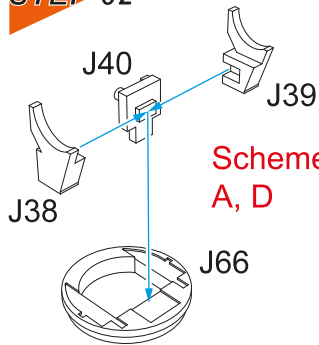

STEP 63

Scheme A, D STEP62

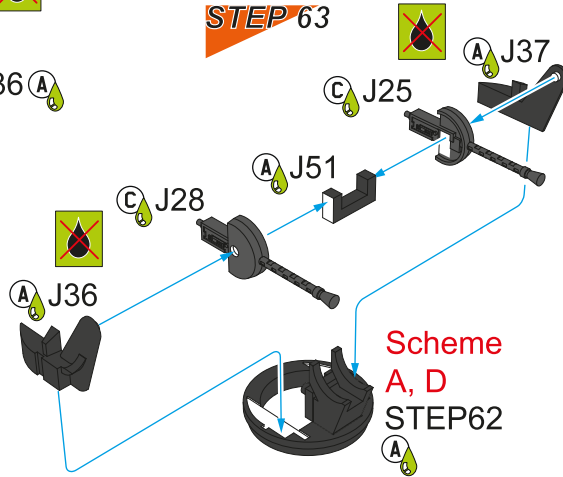

STEP 64

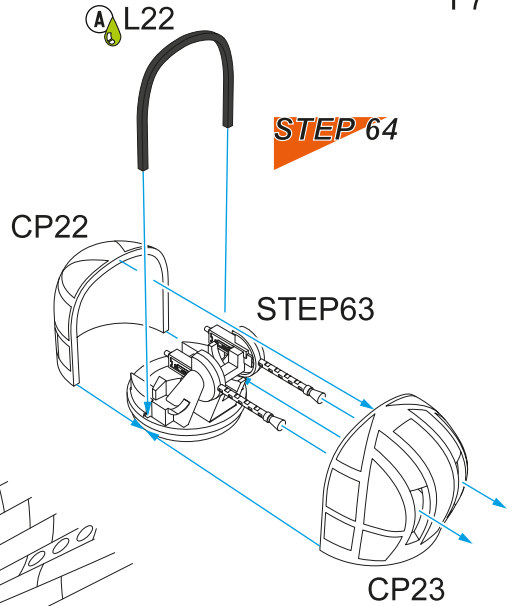

Scheme A, D STEP61

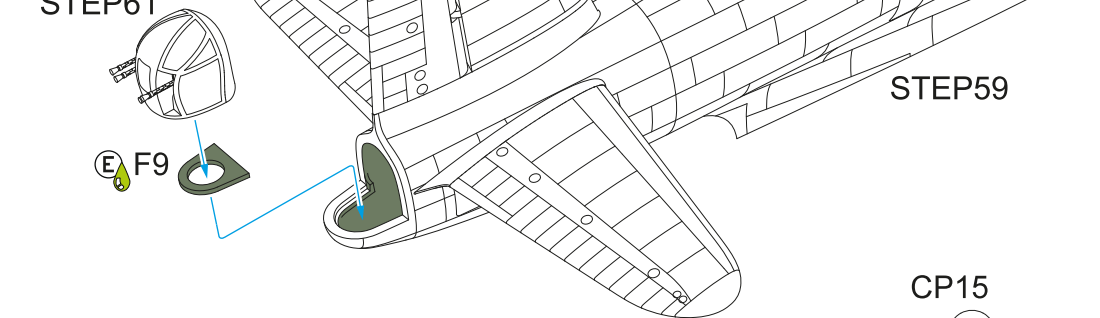

STEP 66

Scheme A, D STEP65

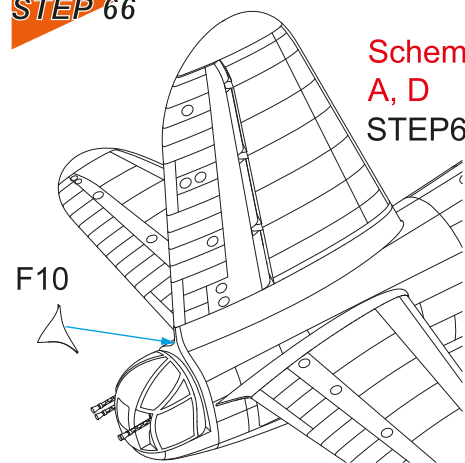

STEP 67

For slid-back position, glue is not necessary

Scheme STEP64 A, D

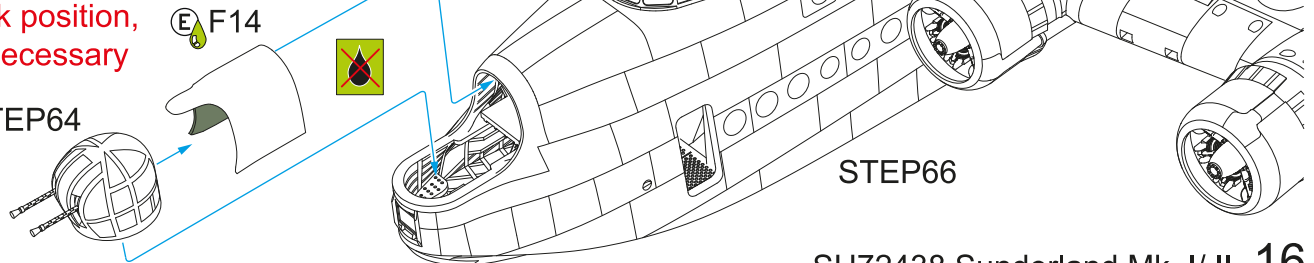

STEP 68

Scheme B, C

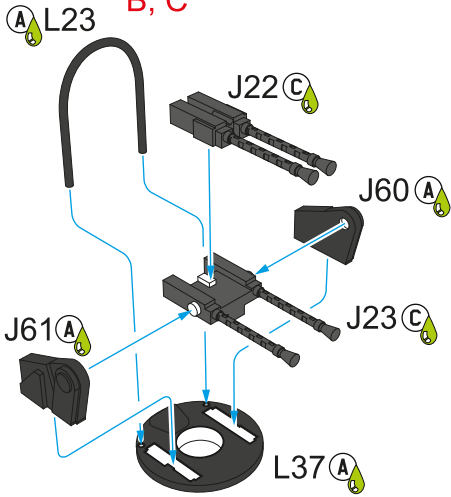

STEP 69

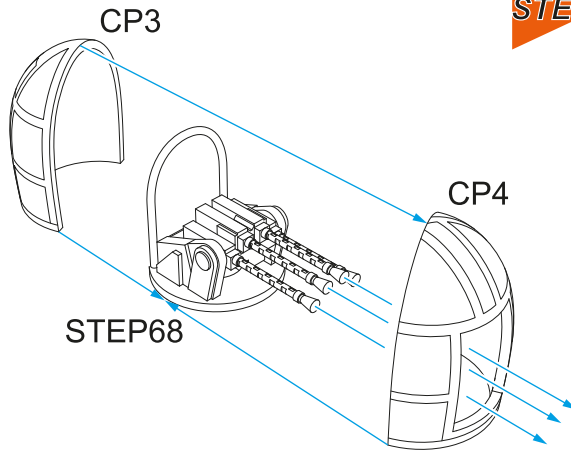

STEP 70

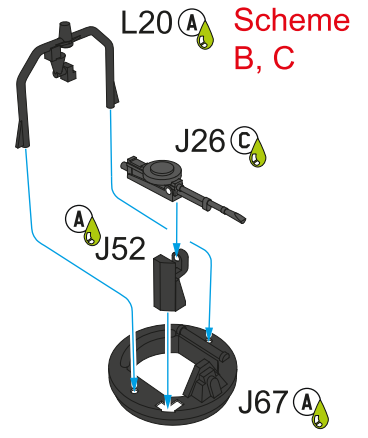

STEP 72

Scheme B, C

STEP 69

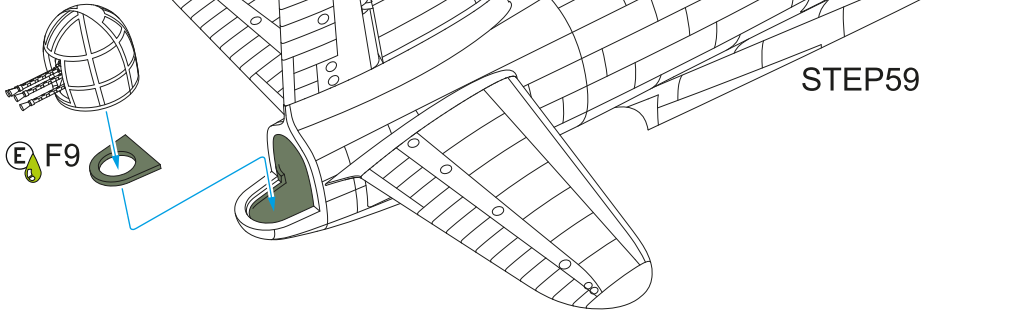

STEP 71

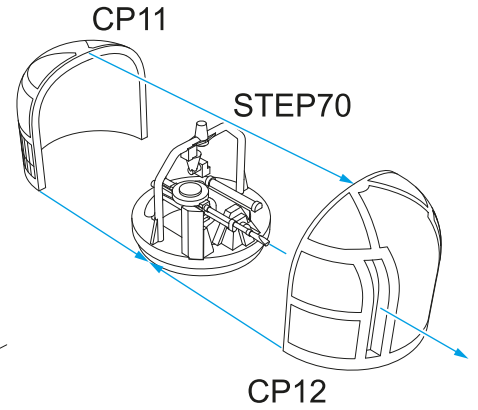

STEP 73

Scheme B, C

STEP 72

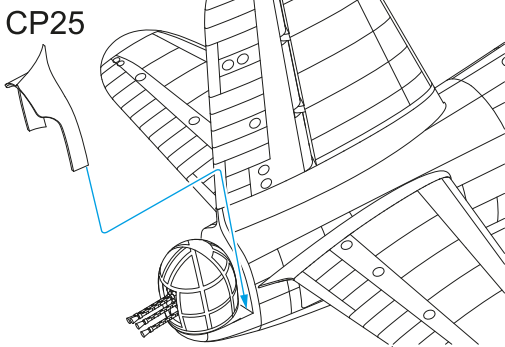

STEP 74

For slid-back position, glue is not necessary

F12



Scheme B, C

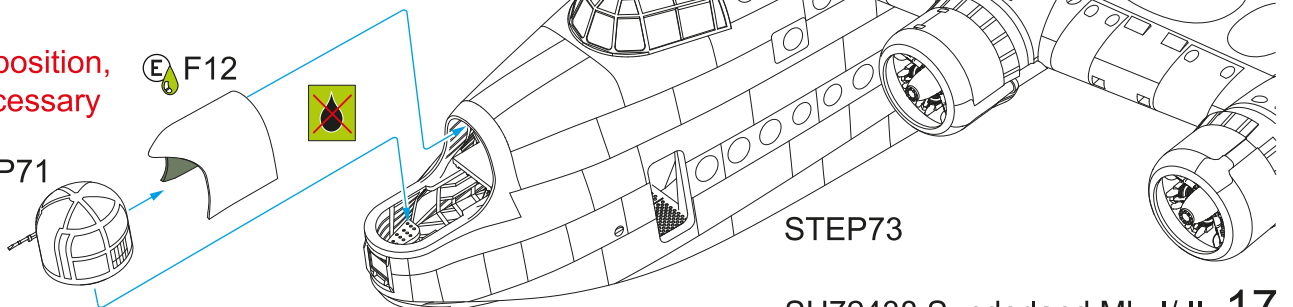

STEP 73

STEP 78

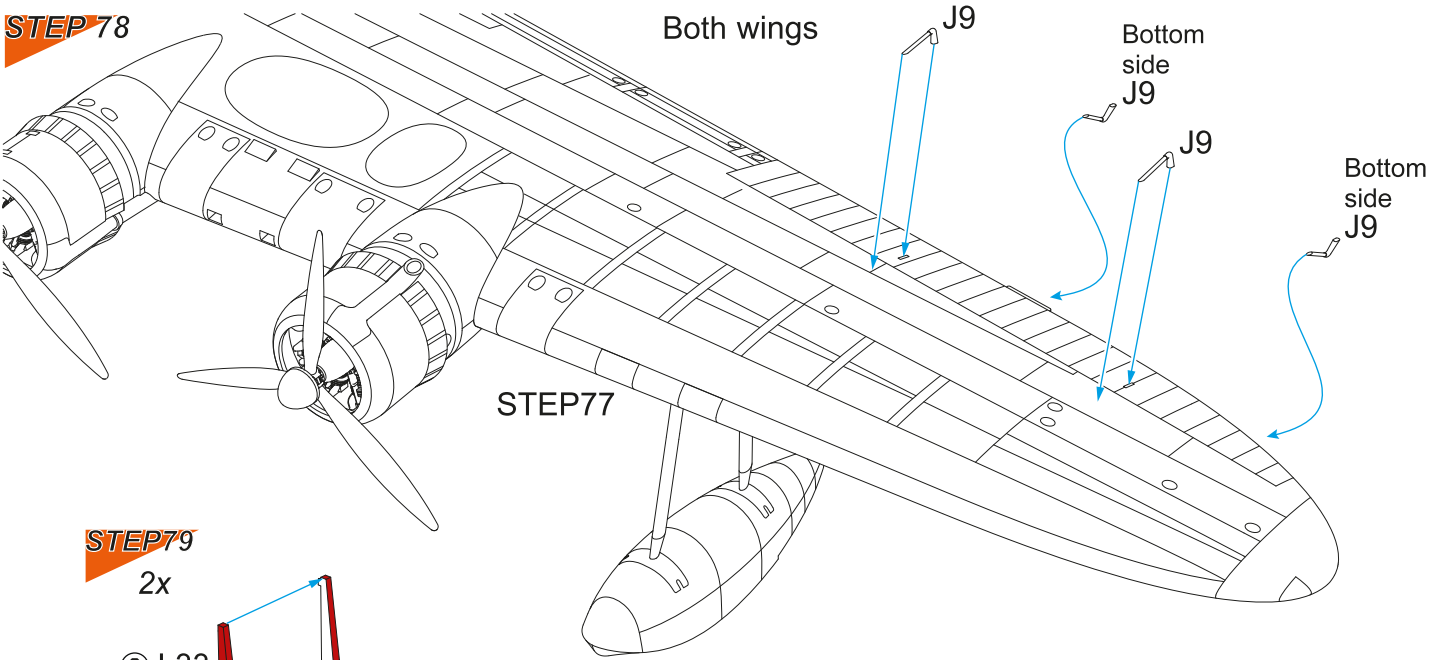

STEP 79

2x

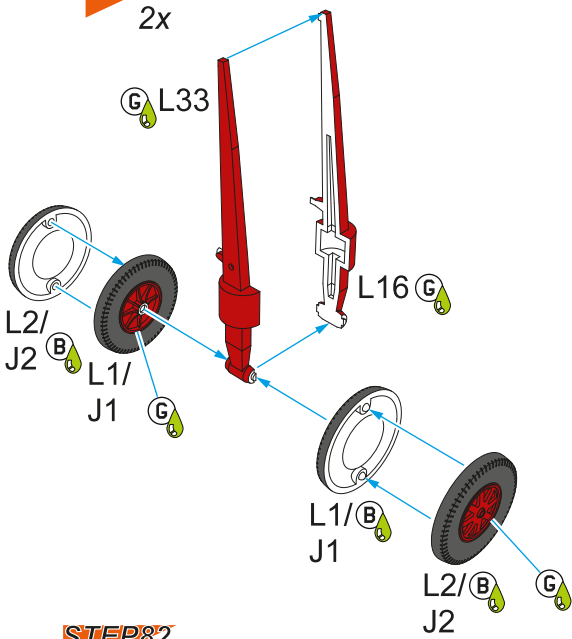

STEP 81

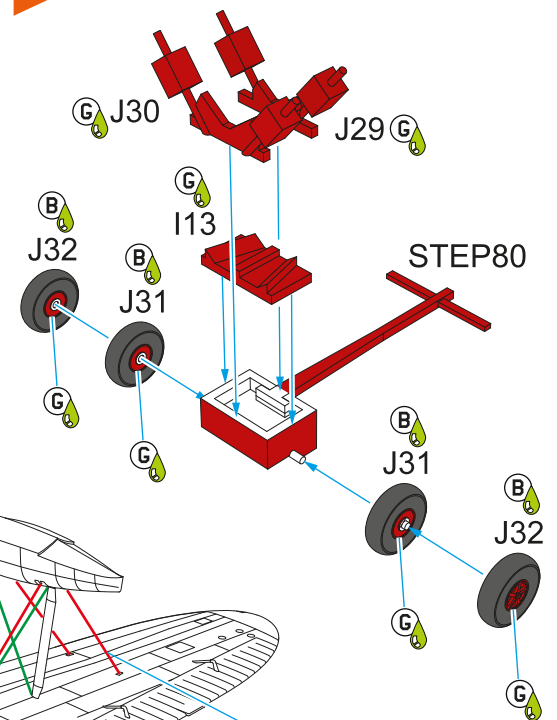

STEP 82

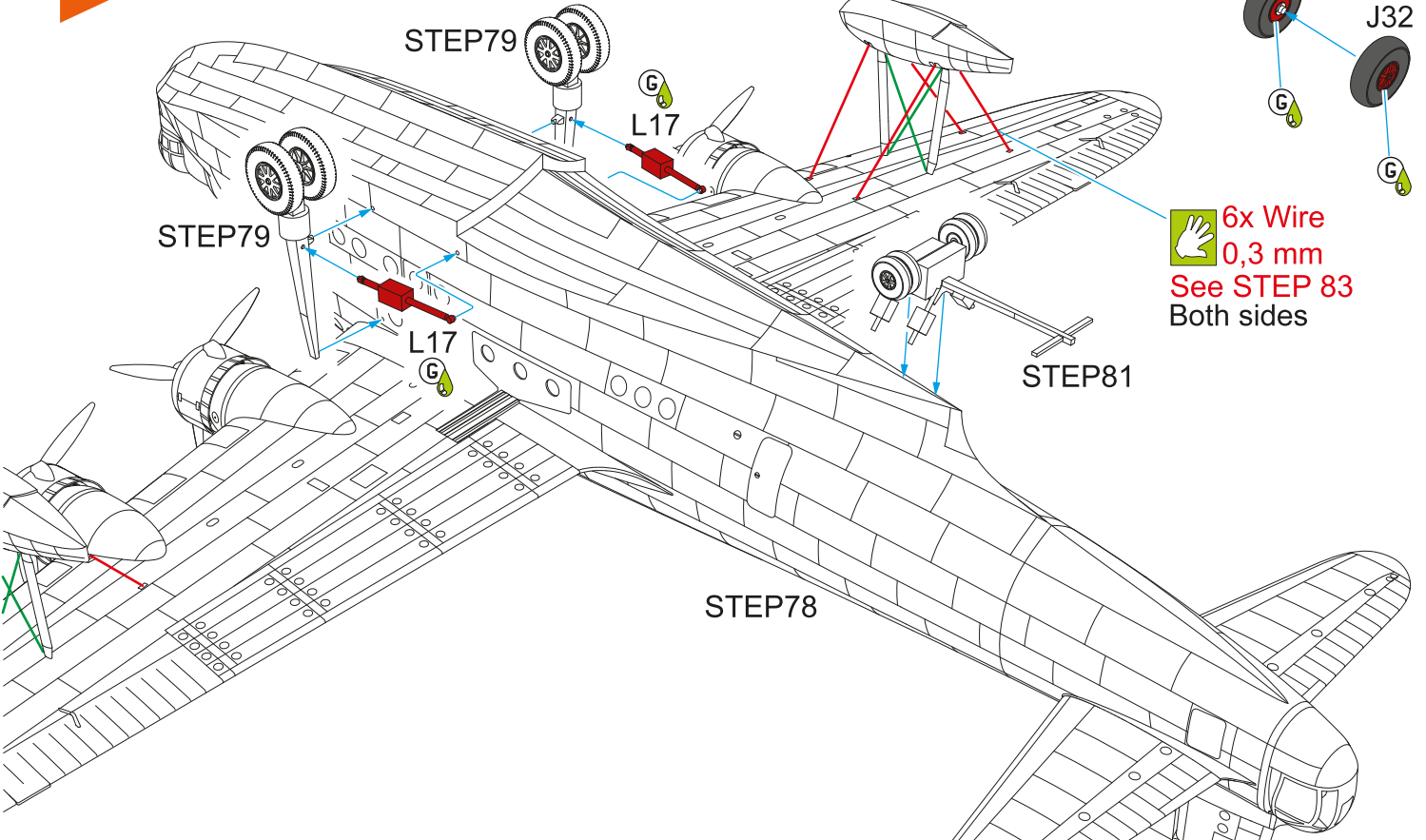

STEP83

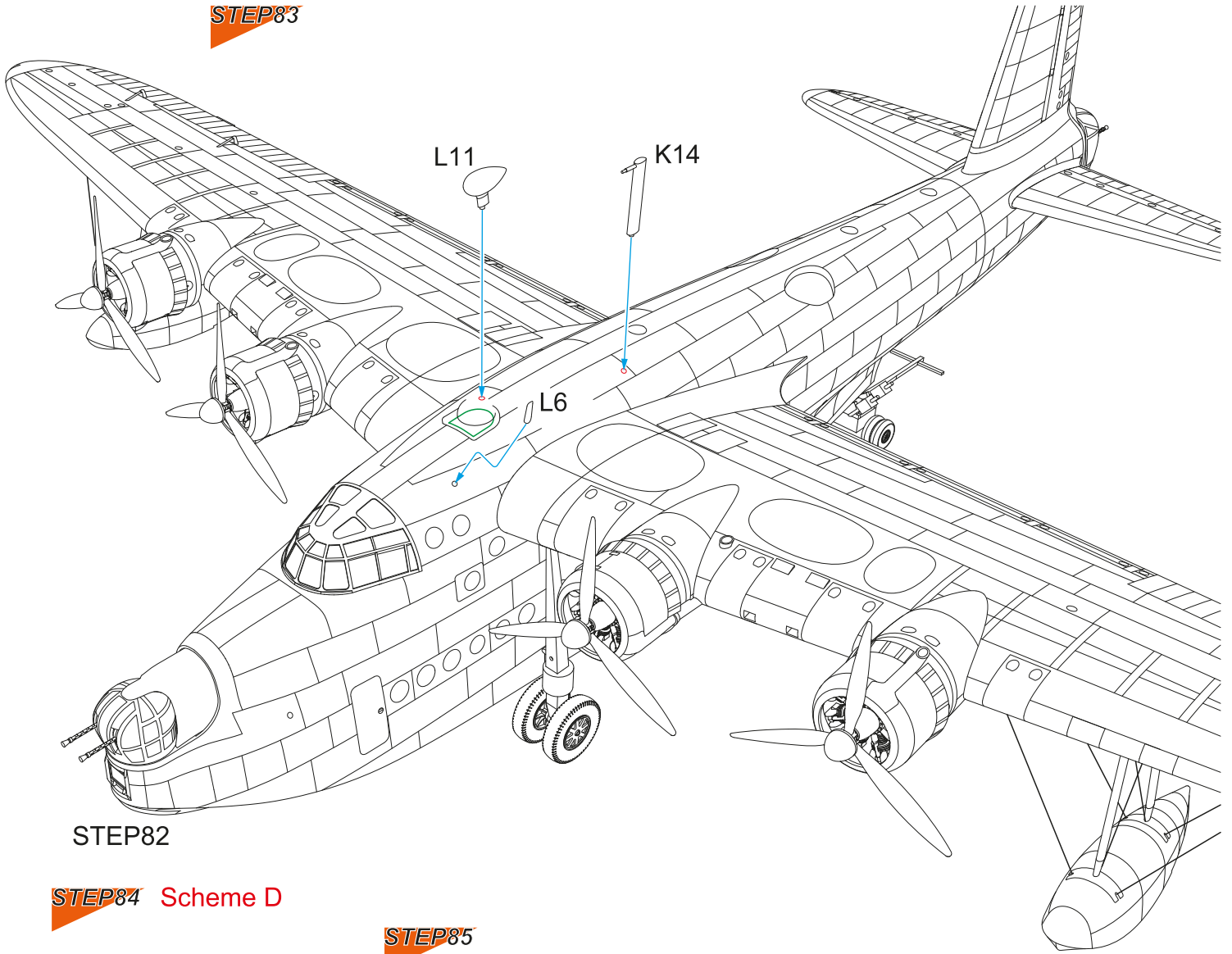

STEP82

STEP84 Scheme D

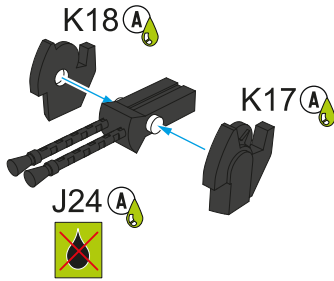

STEP85

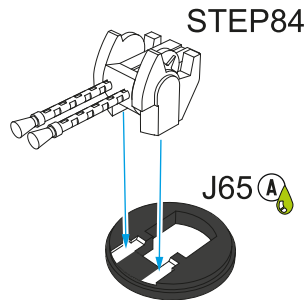

STEP86

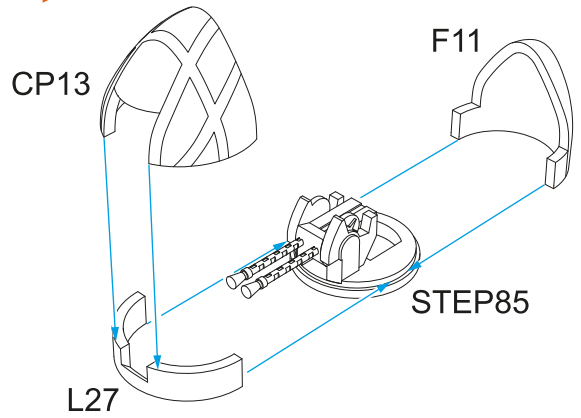

STEP87

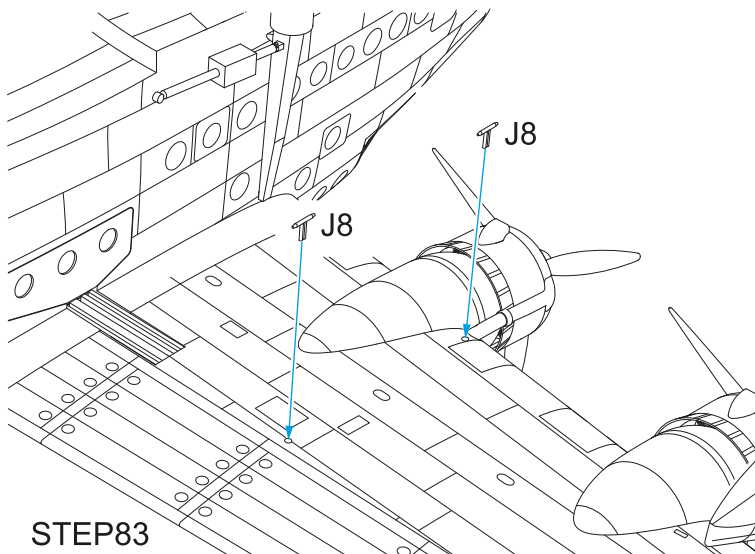

STEP83

STEP88

2x
**Scheme
A, B, D**

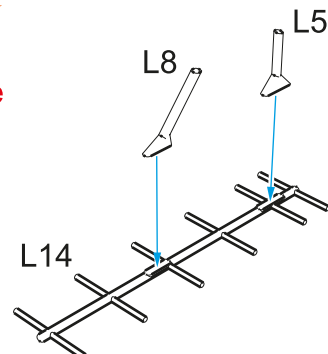

STEP89

STEP87

Scheme A, B, D
STEP88
Both sides

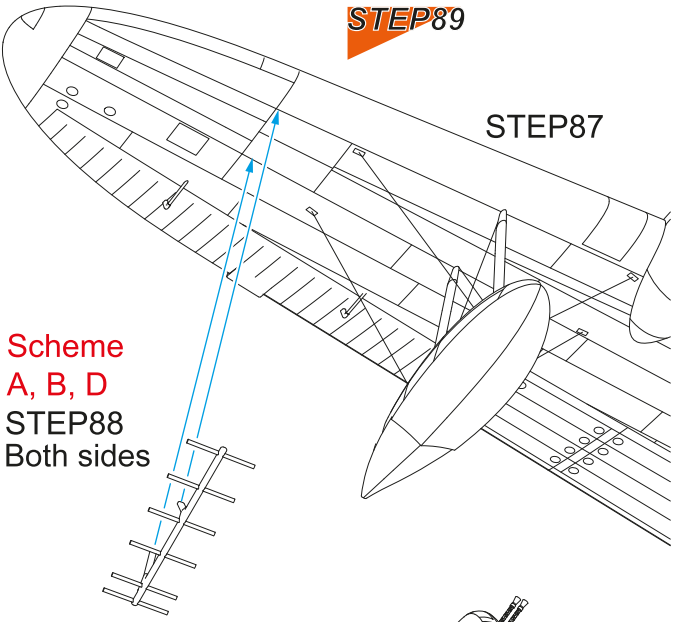

STEP90

Scheme A, B, D

4x L13

STEP89

11.5mm

18.0mm

4x Ø0.6mm

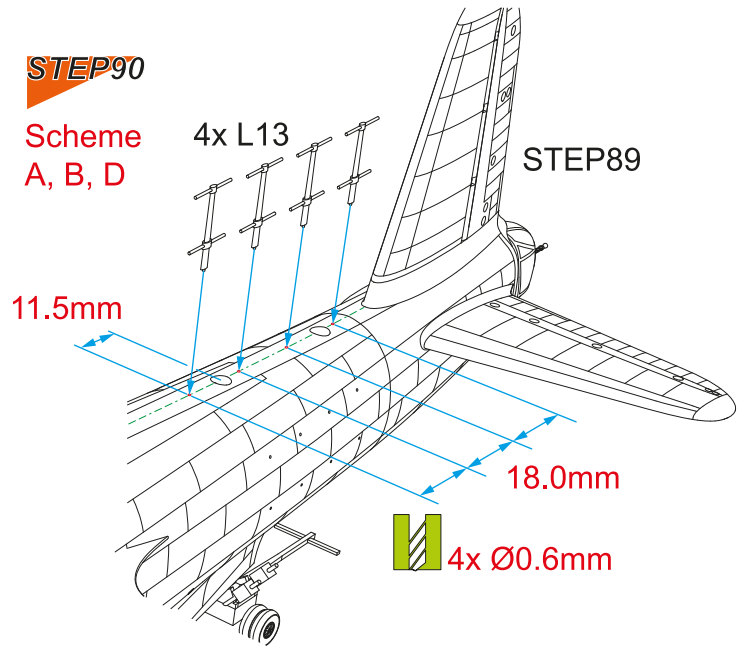

STEP91

STEP86
Scheme D



Ⓒ J53

Ⓒ J16

Scheme A, B, C

Ⓔ J54

J53 Ⓒ

J16 Ⓒ

J54 Ⓔ

STEP90
(STEP42)

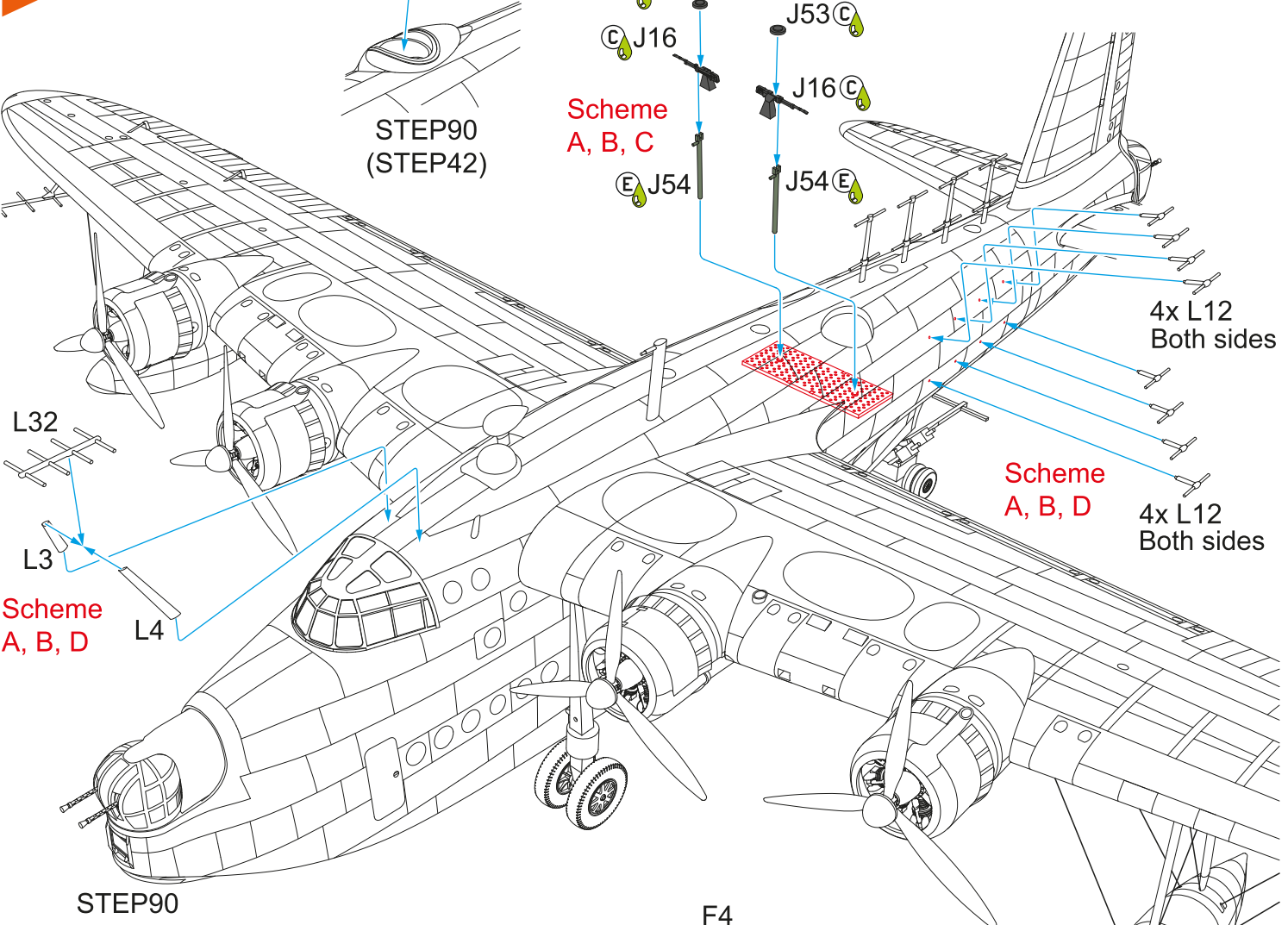

4x L12
Both sides

Scheme A, B, D

4x L12
Both sides

Scheme A, B, D

L32

L3

L4

STEP90

Interior view
Scheme A, B, C

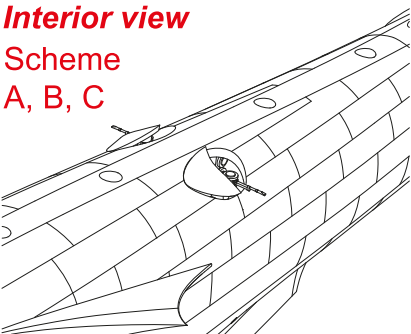

STEP92

Scheme A, B, C

F4

F3

Ⓔ

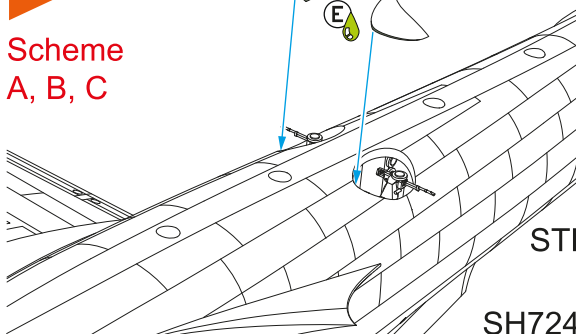

STEP91

Short Sunderland Mk.II, W3983/RB-R, No.10 Sqn. RAAF, based at Pembroke, Wales, latter half of 1941. On 15 May 1942, W3983 carried out an attack on a German submarine, during which it was damaged, begun to lose fuel and consequently had to emergency land on the sea. The machine was eventually towed to Gibraltar and repaired.

Short Sunderland Mk.II, W3983/RB-R, No.10 Sqn. RAAF, základna Pembroke, Wales, druhá polovina roku 1941. 15. května 1942 zaútočil W3983 na ponorku. Při útoku byl poškozen a pro nedostatek paliva přistál na moři. Byl odtážen do Gibraltaru, kde byl i opraven.

Scheme A

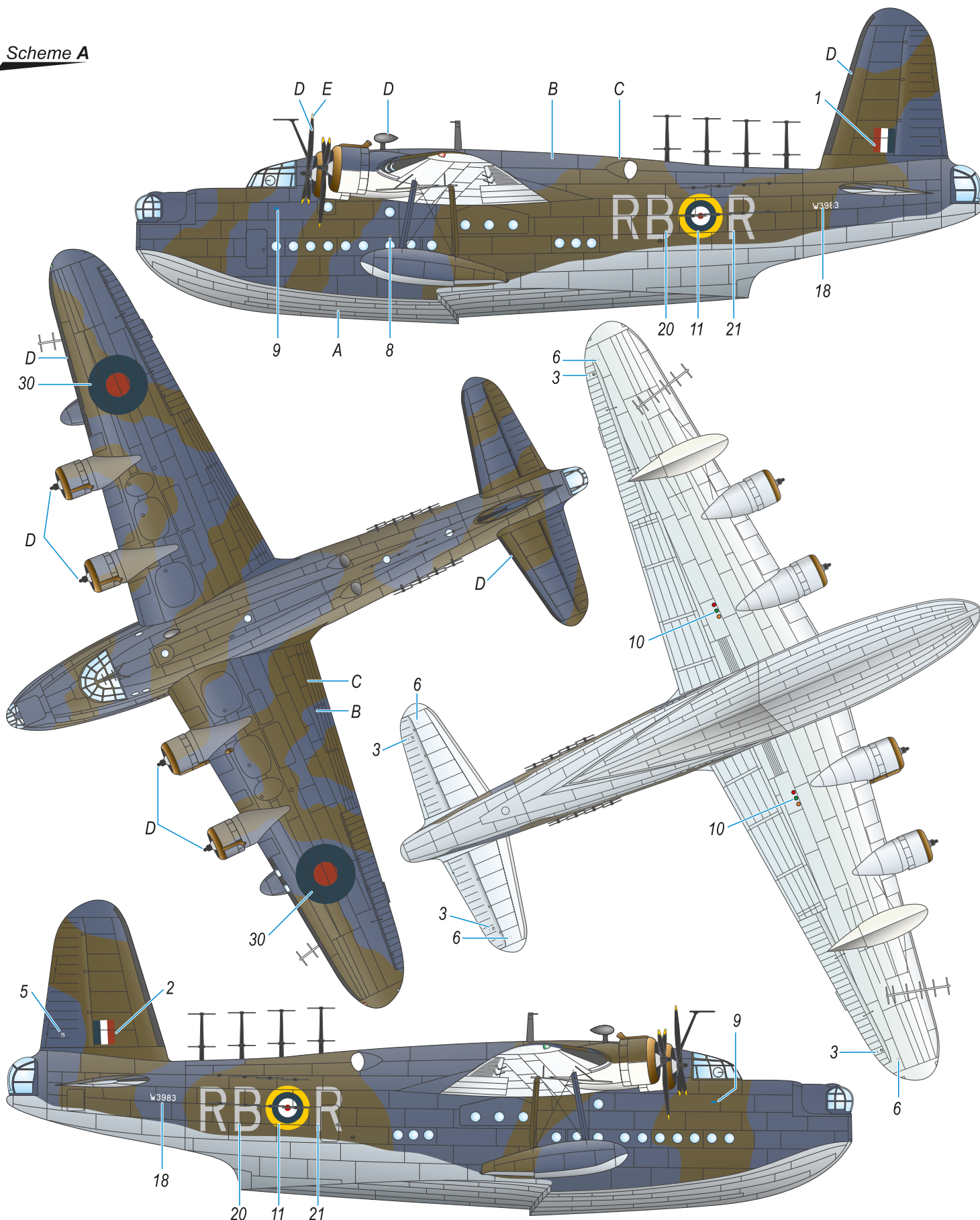

- | | | | | |
|--|---|---|---|--------------------------------------|
| A Aluminium paint
hliníková
H8+11 / C8+62 | B Extra Dark Sea Grey
velmi tmavá mořská šedá
H / C333 | C Dark Slate Grey
tmavá břidlicová šedá
H78 / C38 50%
H32 / C40 50% | D Flat Black
matná černá
H12 / C33 | E Yellow
žlutá
H / C329 |
|--|---|---|---|--------------------------------------|

Short Sunderland Mk.II, W3981/ZM-W, No.201 Sqn. RAF, based at Pembroke, Wales, latter half of 1941. In December 1941, the machine was transferred to Alexandria, Egypt to perform transport duties, and returned to the UK in February the following year. On landing on 12 February 1942 its wing tip was torn off by a tree. After being repaired, W3981 went on serving to 4.(C) OTU training unit.

Short Sunderland Mk.II, W3981/ZM-W, No.201 Sqn. RAF, základna Pembroke, Wales, druhá polovina roku 1941. V prosinci 1941 byl přesunut do Alexandrie (Egypt) k transportním úkolům. V únoru 1942 se vrátil zpět. Při přistání 12 února 1942 přišel o konec křídla nárazem do stromu. Po opravě byl přesunut k cvičné jednotce 4. (C) OTU.

Scheme B

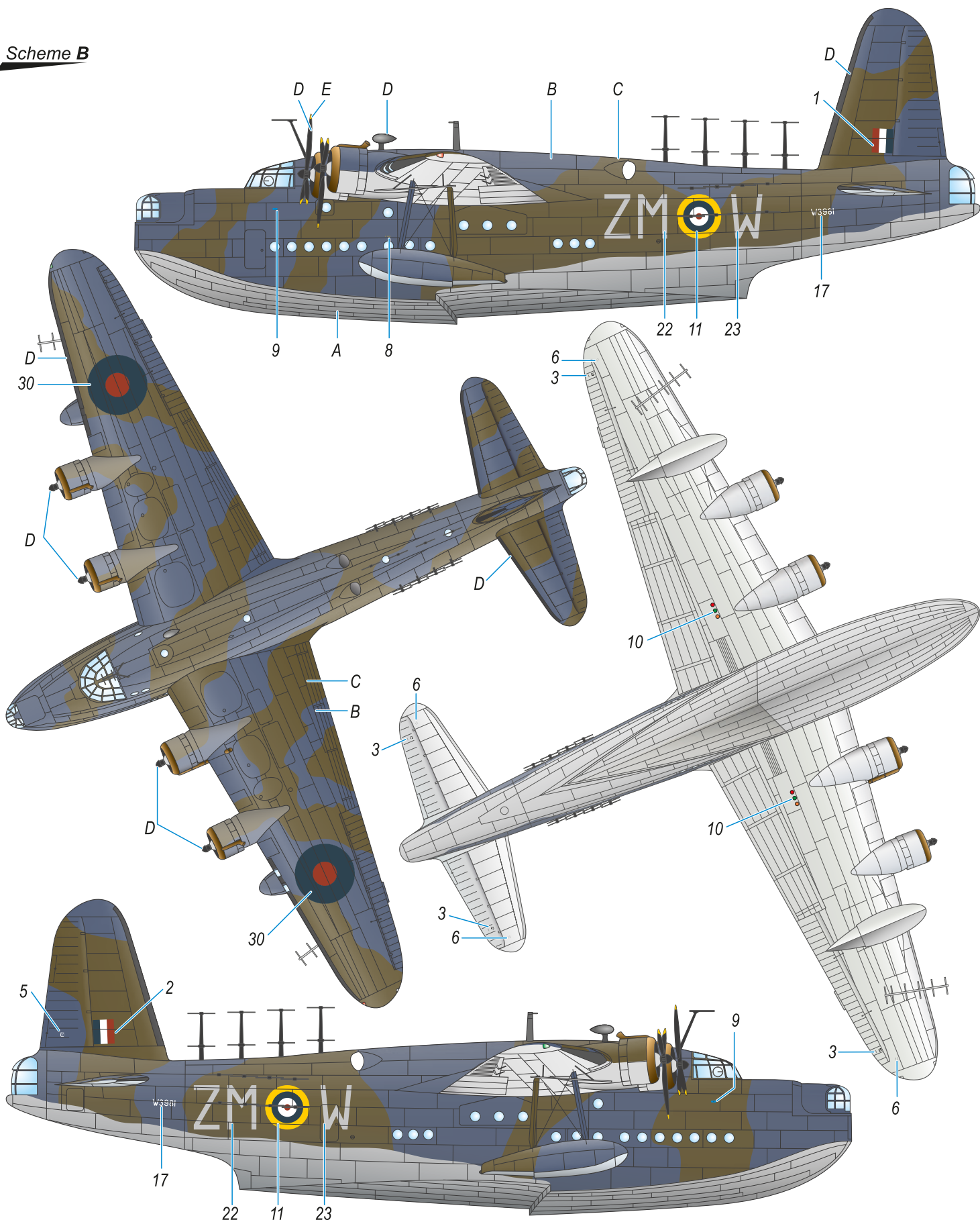

- | | | | | |
|---|---|---|---|--------------------------------------|
| A Sky Grey
sv. šedá
H / C325 | B Extra Dark Sea Grey
velmi tmavá mořská šedá
H / C333 | C Dark Slate Grey
tmavá břidlicová šedá
H78 / C38 50%
H32 / C40 50% | D Flat Black
matná černá
H12 / C33 | E Yellow
žlutá
H / C329 |
|---|---|---|---|--------------------------------------|

Short Sunderland Mk.II, L2160/NM-X, No.230 Sqn. RAF, detached at Skaramagas, Greece, April 1941. On the night of 16-17 April 1941, Sunderland L2160 took part in the evacuation of the Czechoslovak intelligence group 'Marie' from the port of Kotor, Yugoslavia.

Short Sunderland Mk.I, L2160/NM-X, No.230 Sqn. RAF, detašovaný na základně Scaramanga, Řecko, duben 1941. V noci z 16. na 17. 4. 1941 se stroj podílel na evakuaci československé zpravodajské skupiny "Marie" z jugoslávského Kotoru.

Scheme C

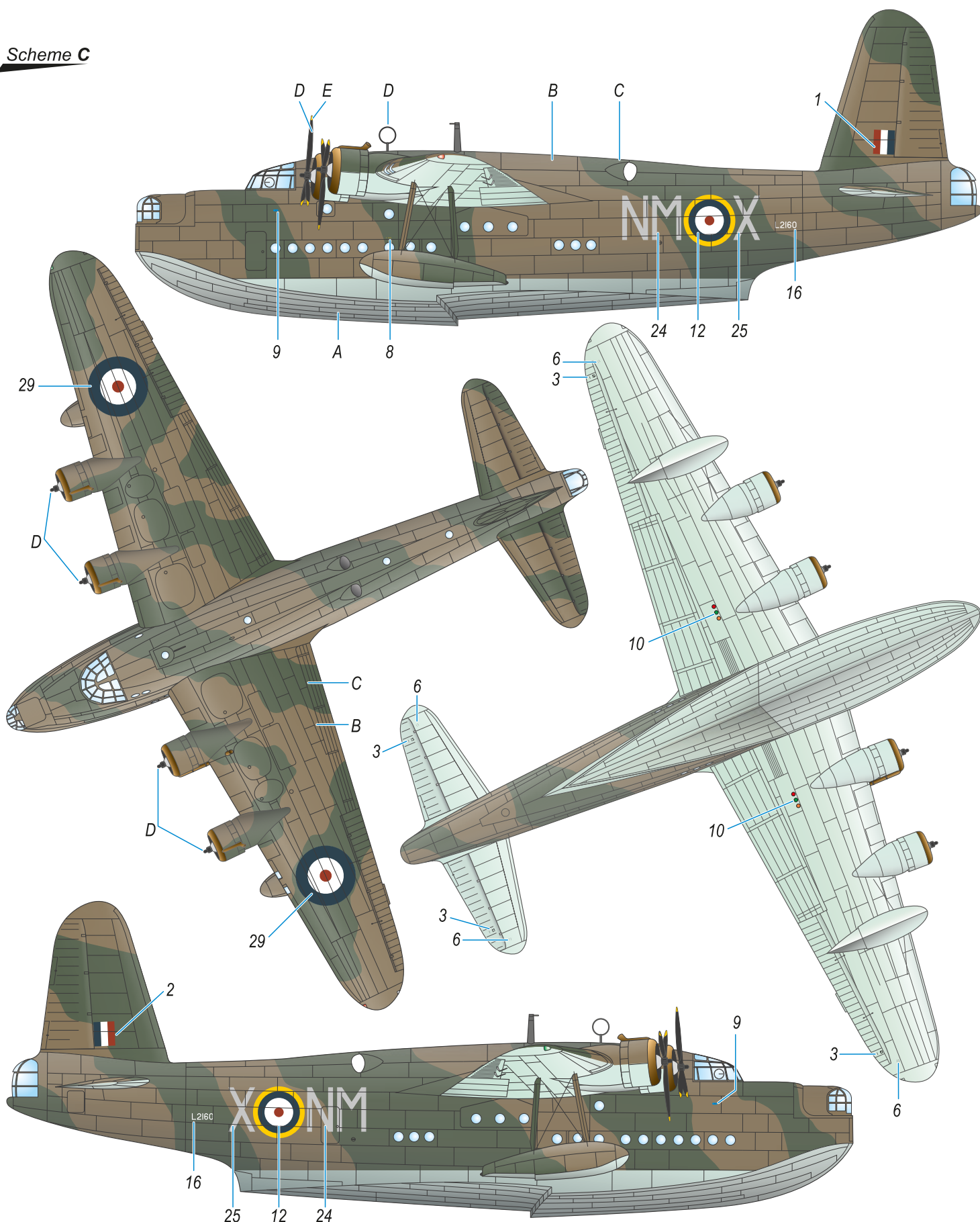

- | | | | | |
|---|--|--|---|--------------------------------------|
| A Sky
sv. modrozelená
C368 | B Dark Earth
tmavá zemitá
H72 / C22 | C Dark Green
tmavá zelená
H73 / C23 | D Flat Black
matná černá
H12 / C33 | E Yellow
žlutá
H / C329 |
|---|--|--|---|--------------------------------------|

Short Sunderland Mk.II, T9114/E, No.461 (RAAF) Sqn. RAF, based at Pembroke, Wales, Spring 1943. On 29 May 1943, T9114 taking part in a wide scale rescue operation, sustained serious damage to its lower hull, where a huge wave made a hole seven by four feet during the attempt to take off. The rescued crews of a RAF Whitley and Sunderland JM675, which itself had crashed the day before while rescuing the Whittle crew, were eventually taken ashore by a Royal Navy destroyer. F/O Singleton, the captain of Sunderland T9114, decided not to push the luck any further and successfully landed his crippled machine on a grassy aerodrome at RAF Angle. The machine was a write-off, the crew escaped without any injury though.

Short Sunderland Mk.II, T9114/E, No.461 (RAAF) Sqn. RAF, základna Pembroke, Wales, jaro 1943. V průběhu rozsáhlé záchranné akce 29. května 1943 utrpěl vážné poškození trupu pod čarou ponoru při snaze přistát na otevřeném moři (otvor cca 2x1 metr). T9114 s osádkou F/O G. Singletona se snažil zachránit osádku sestřeleného bombardéru Whitley a osádku Sunderlandu JM675, který havaroval při předchozím pokusu nabrat trosečníky. Všechny trosečníky nakonec zachránila bojová loď Royal Navy. F/O G. Singleton neriskoval přistání na vodě a perfektně přistál na základně RAF Angle na trávu. Stroj byl odepsán, ale osádka vyvázla bez zranění.

Scheme D

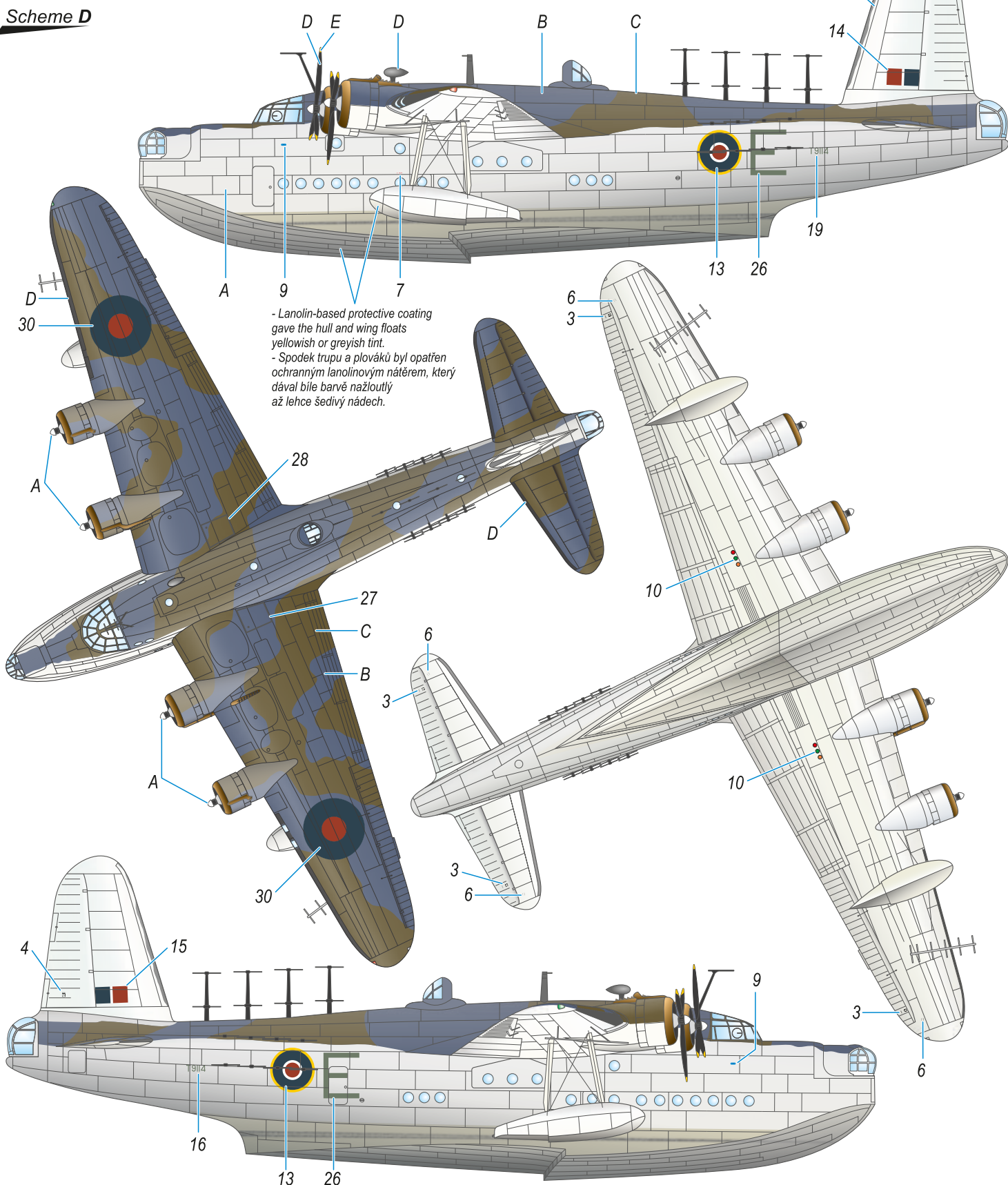

- Lanolin-based protective coating gave the hull and wing floats yellowish or greyish tint.
 - Spodek trupu a plováků byl opatřen ochranným lanolinovým nátěrem, který dával bílé barvě nažloutlý až lehce šedivý nádech.

- | | | | | |
|--|---|---|---|--------------------------------------|
| A Flat White
matná bílá
H11 / C62 | B Extra Dark Sea Grey
velmi tmavá mořská šedá
H / C333 | C Dark Slate Grey
tmavá břidlicová šedá
H78 / C38 50%
H32 / C40 50% | D Flat Black
matná černá
H12 / C33 | E Yellow
žlutá
H / C329 |
|--|---|---|---|--------------------------------------|

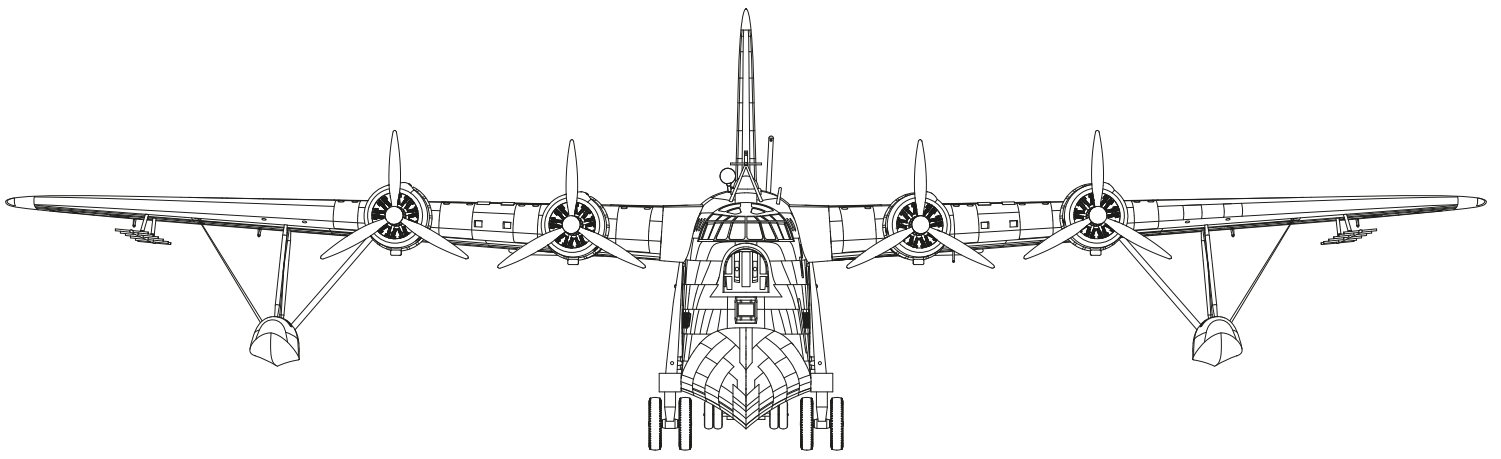

Star Dust
weathering pigments



1/72
SH72453

DH.100 Vampire Mk.3 'European and American Operators'



1/72
SH72455

DH.100 Vampire FB.Mk.9 'Tropicalised Fighter-Bomber'

M72033 DH.100 Vampire Mk.3/5/9 and export variants MASK

Special
MASK

1/72 SH72437



A.W. Meteor NF Mk.11 'RAF Squadrons'



1/72 SH72360

A.W. Meteor NF MK.12



1/72 SH72364

A.W. Meteor NF Mk.14 'The Last of Night Fighters'

M72031 A.W. Meteor aNF Mk.11/12/13 MASK

M72027 A.W. Meteor NF Mk.14 MASK

**Special
MASK**

**special
HOBBY**

[facebook.com/specialhobby](https://www.facebook.com/specialhobby)
WWW.SPECIALHOBBY.EU | WWW.CMCKITS.COM

CMK
CZECH
MASTER'S KITS

1/72 SH72343

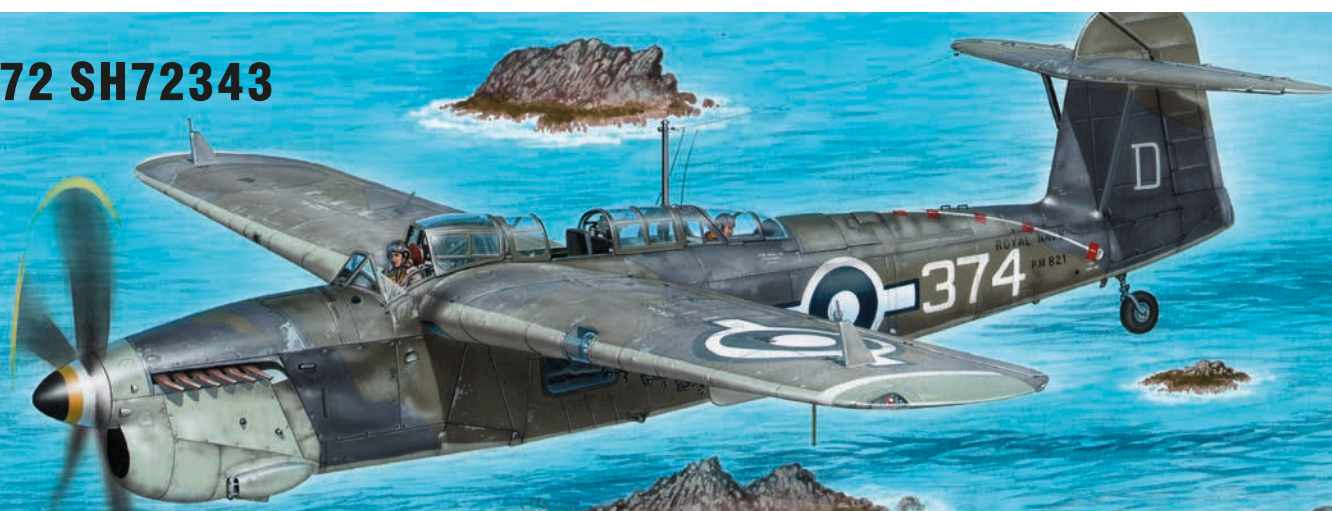

Fairey Barracuda Mk.II 'Pacific Fleet'

1/72 SH72408



Fairey Barracuda Mk.III 'ASV Mk.XI Radar'

1/72
SH72356



Boulton Paul Balliol 'Civilian and Foreign Users'