

SW 72132

scale 1/72 

TBM-3R



The original Avenger was developed for the U.S. Navy and U.S. Marine corp. as a torpedo bomber, and entered service in 1942. Over time the aircraft was further developed to carry airborne radar in anti-shipping and anti-submarine roles. The TBM-3S was an anti-submarine version produced post WWII at the onset of the Cold War. The TBM-3S usually flew with a TBM-3W as a 'Hunter / Killer' team. The 3S was a converted 3E, with the turret removed, and had a larger rear compartment housing a radar operator / navigator. The radio compartment was retained with its operator, but two sonobuoy launch tubes were installed at the rear. A search light was mounted under the port wing and an AN/APS-4 radar pod under the starboard wing. The Royal Navy / Fleet Air Arm aircraft were designated AS-4 and their air-to-surface radar was mounted in a 'dustbin' type radome under the fuselage. The TBM-3S and similar TBM-3S2 could carry rockets with zero-length launch mounts under each wing. A single acoustic torpedo or 4 bombs / depth-charges could be carried in the bomb-bay. The aircraft had an antenna / receiver for the radar data-link from a TBM-3W. The TBM-3S was used by several countries including Canada, France, Japan, and the Dutch. Details such as canopies and other components varied between countries.

The TBM-R was a converted TBM-3W or TBM-3S. Combat gear was removed and the rear canopy either glazed or covered over. It was developed during the Korean War as a COD (carrier onboard delivery) and had seating for 7 passengers in the rear compartment. It could also carry stretchers in the bomb-bay, or a cargo basket which could quickly be exchanged on the ground or on deck.

VISION SWORD s.r.o. Těšínská 288
739 34 Šenov
CZECH REPUBLIC

www.swordmodels.cz
e-mail: swordmodels@gmail.com

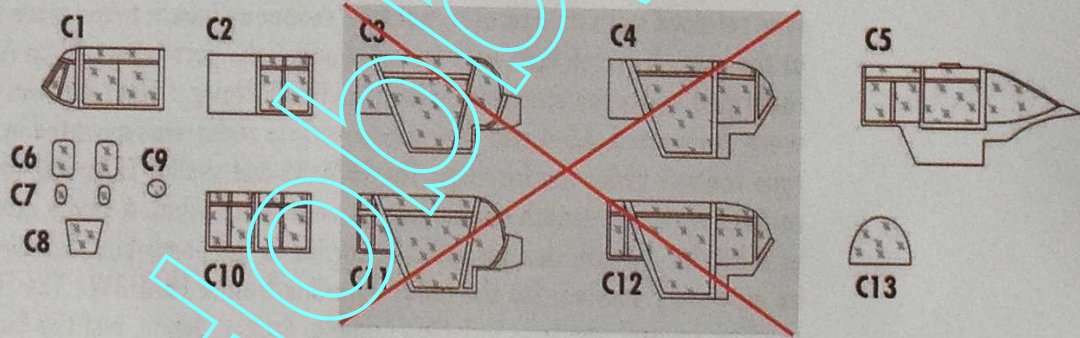
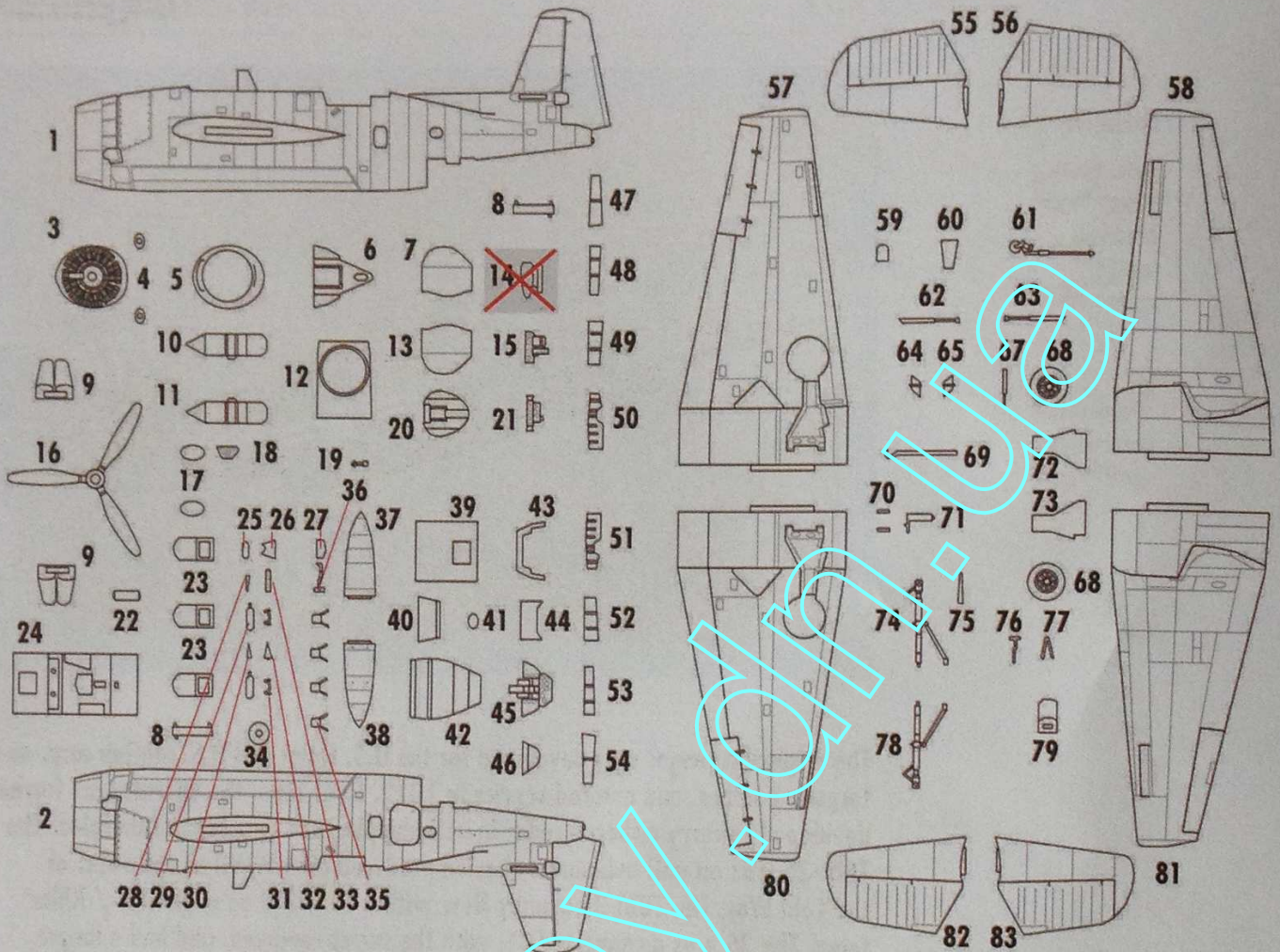

REMOVE	BEND	OPEN HOLE	SCRATCH BUILD	COLOR	SYMMETRICAL ASSEMBLY	OPTION	SECOND GLUE

White	Light Grey	Exhaust	Tyres Black	Black	Bronze Green	Gloss Sea Blue
Silver	Yellow	Chrome	Interior Green	Leather	Engine Grey	

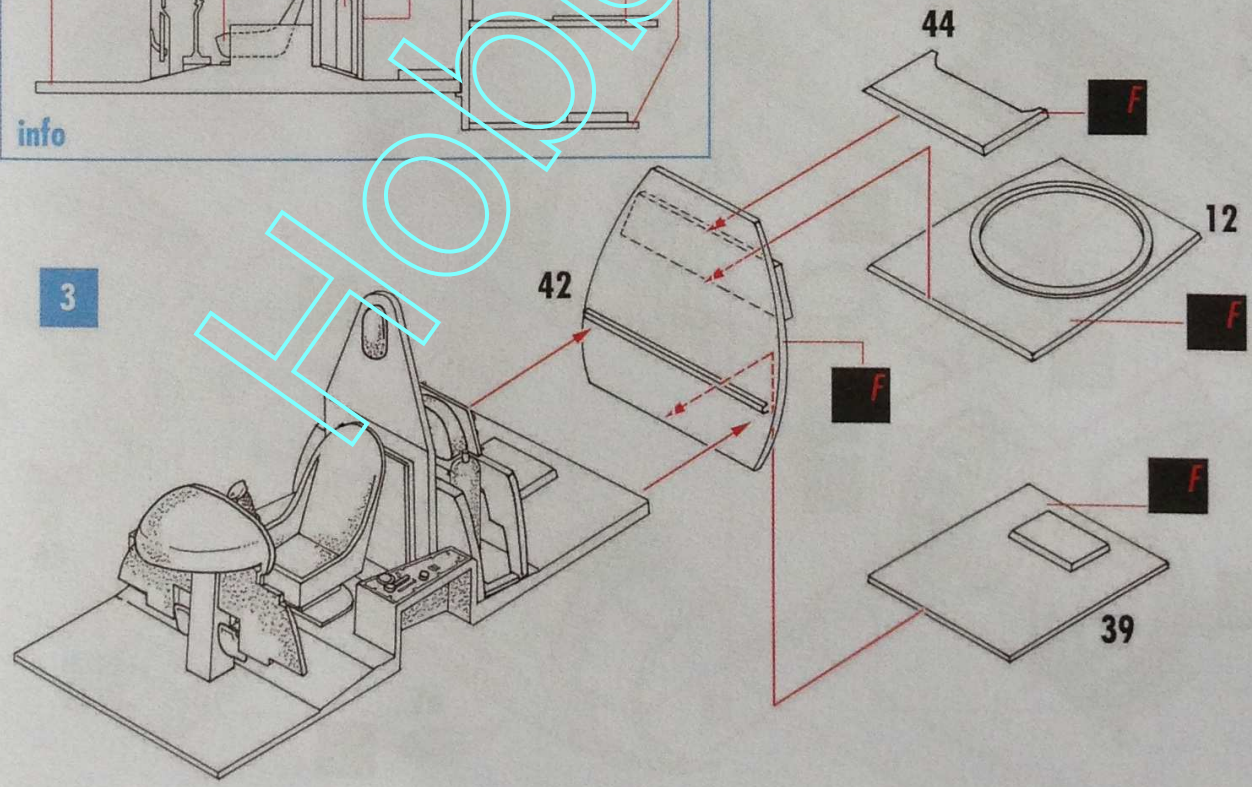
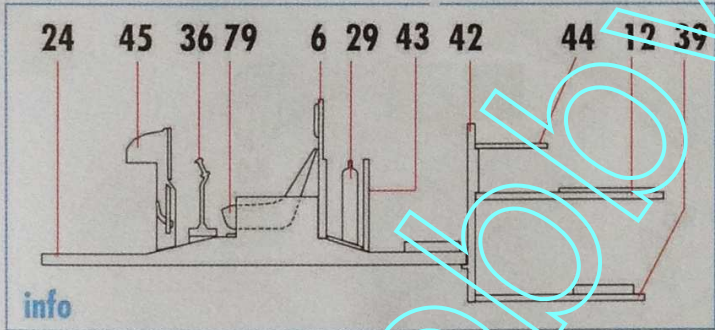
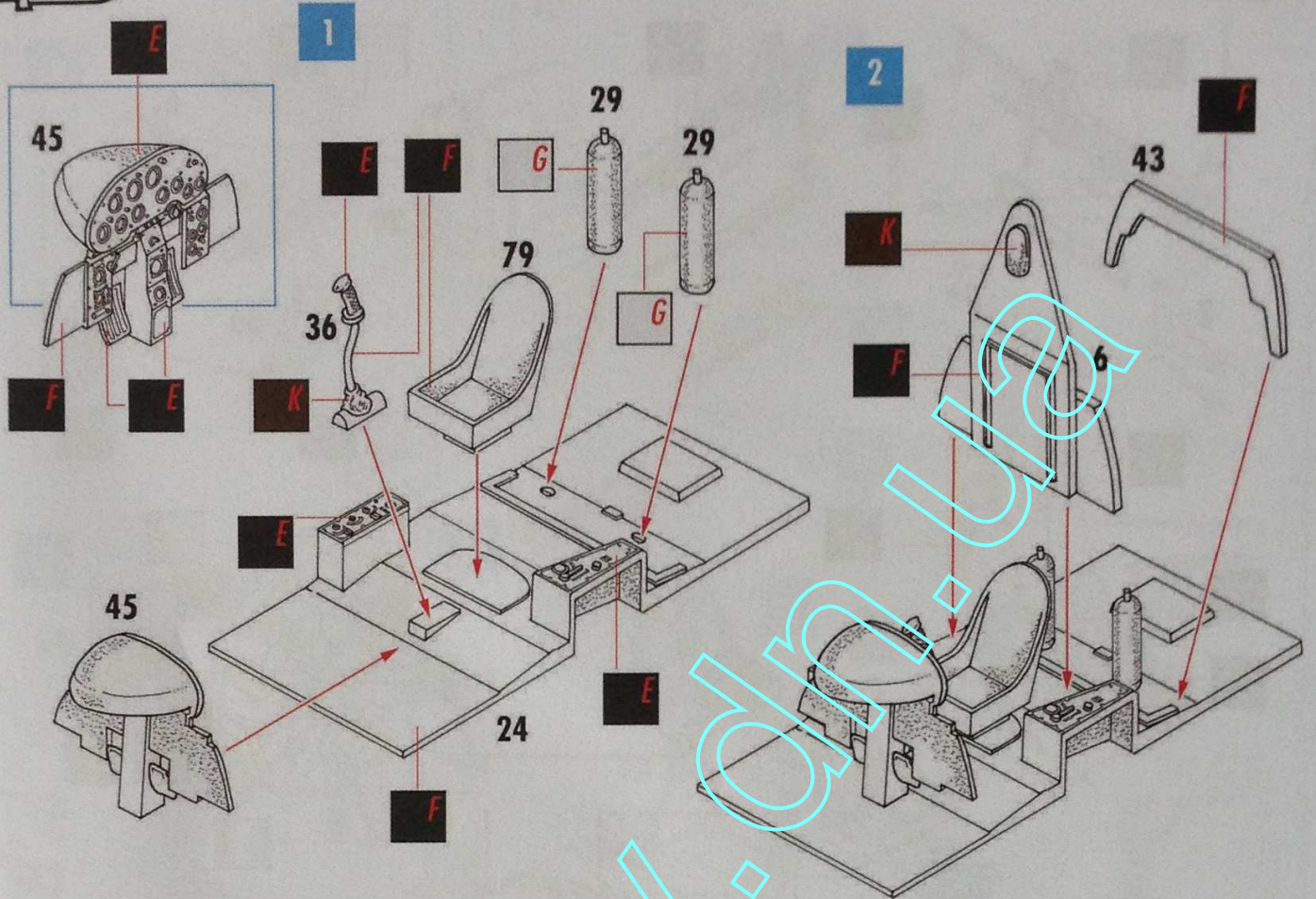

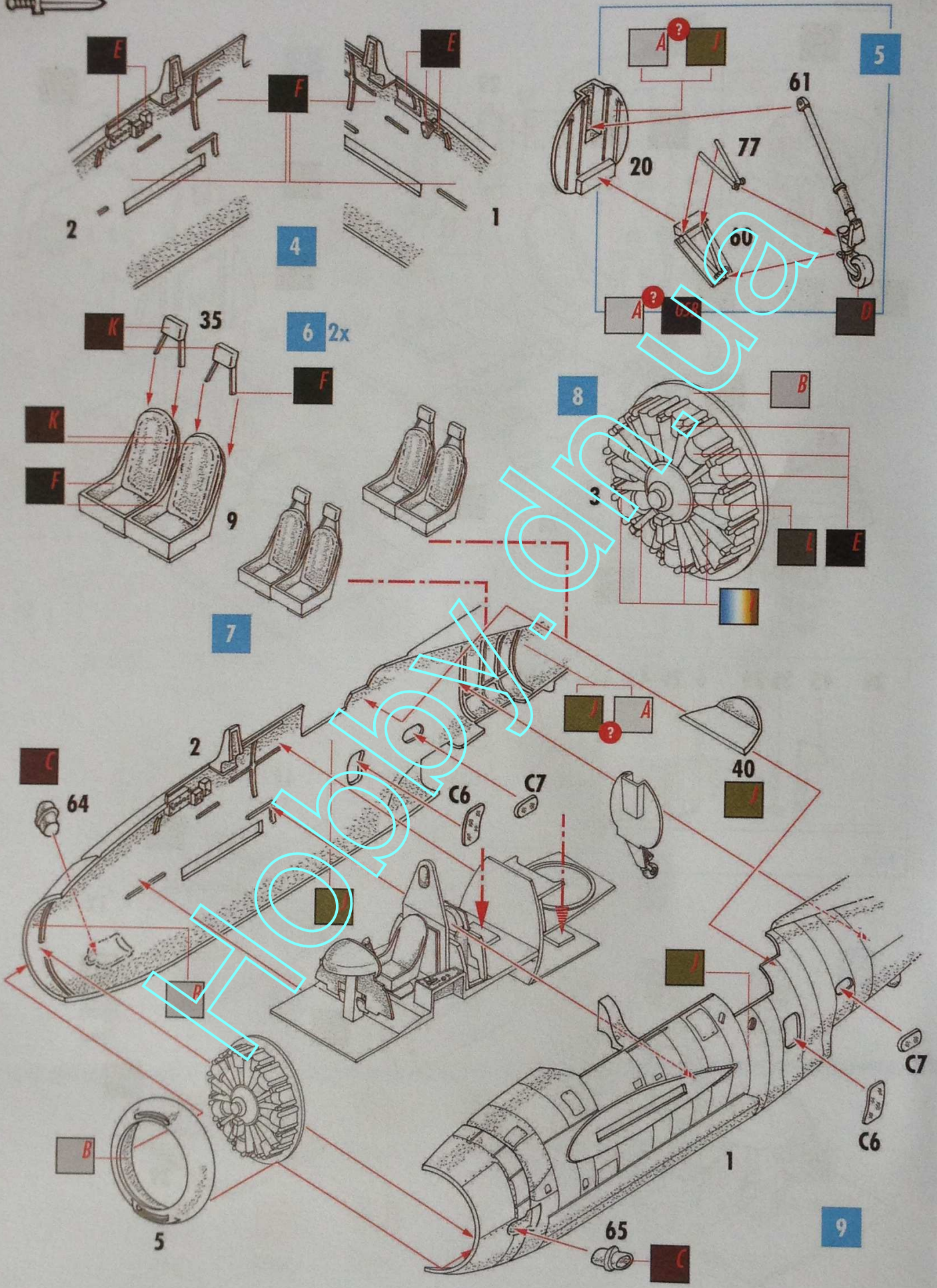

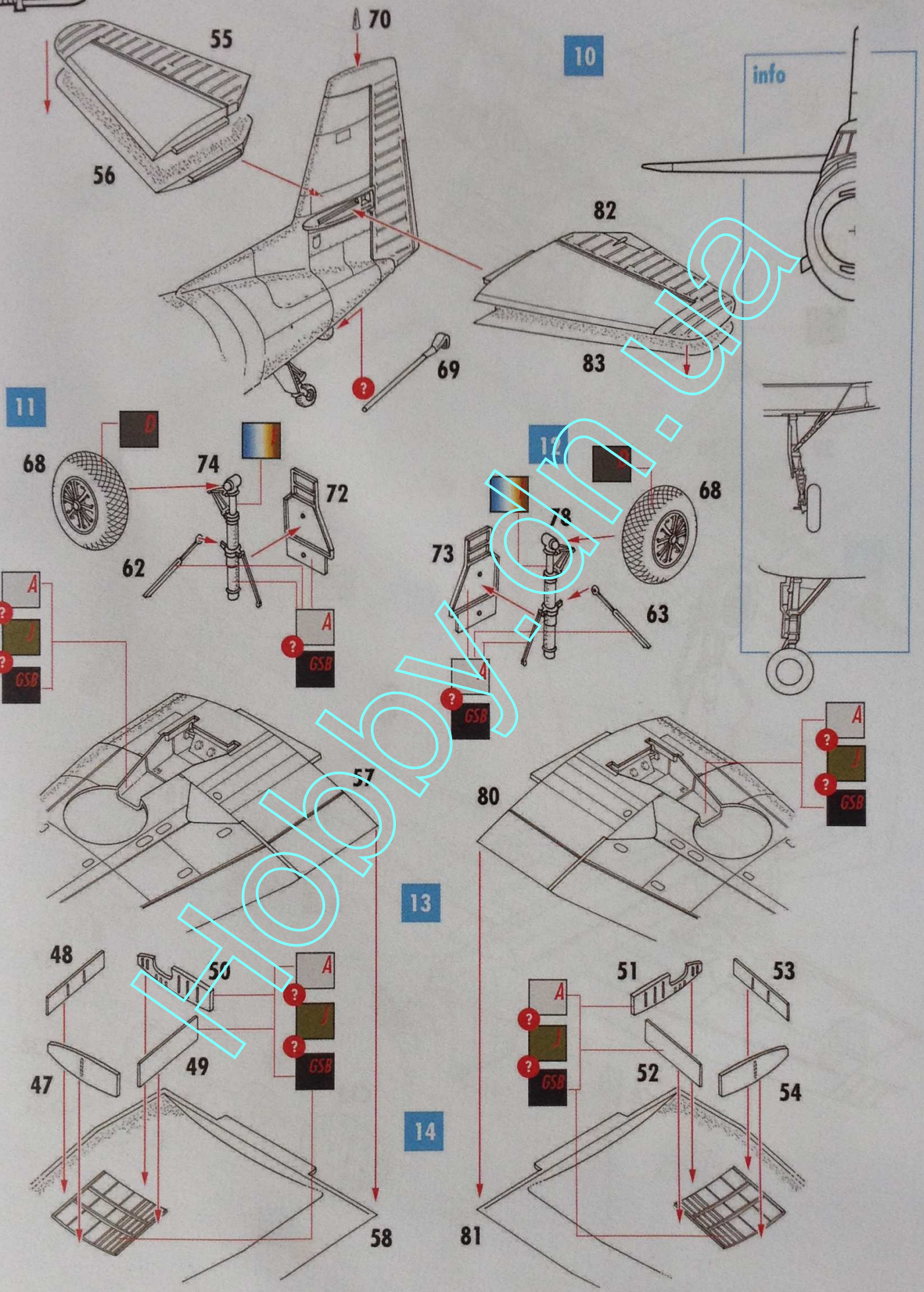

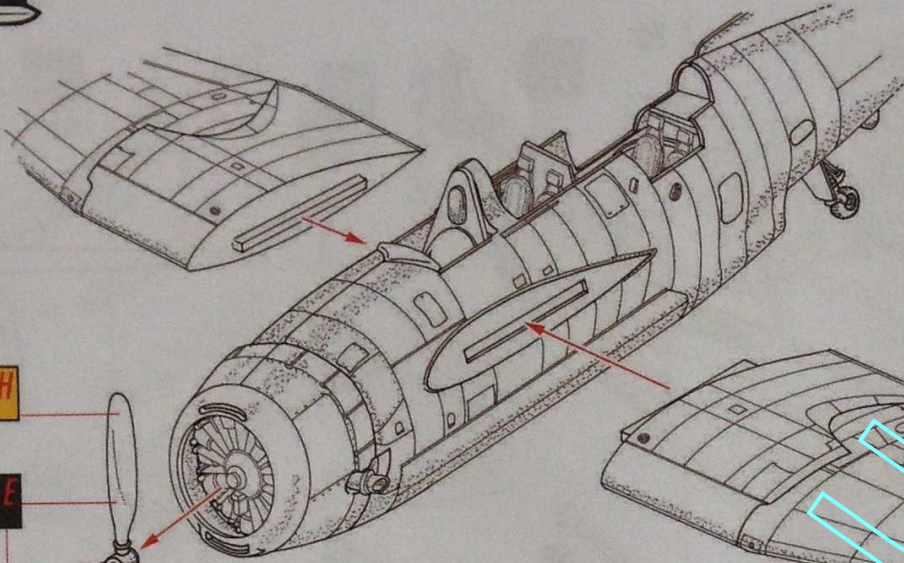

15

H

E

59

16

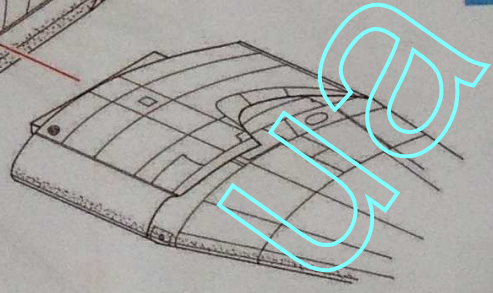

17

22

26

59

16

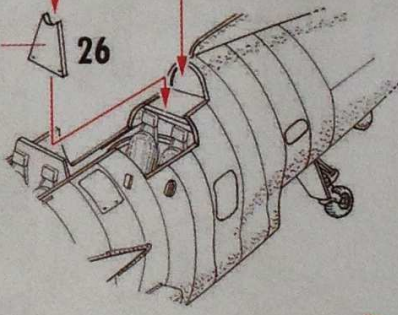
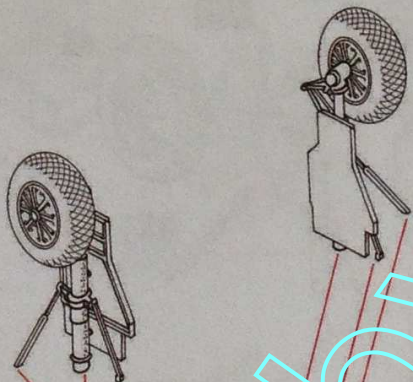

10

11

8

18

?

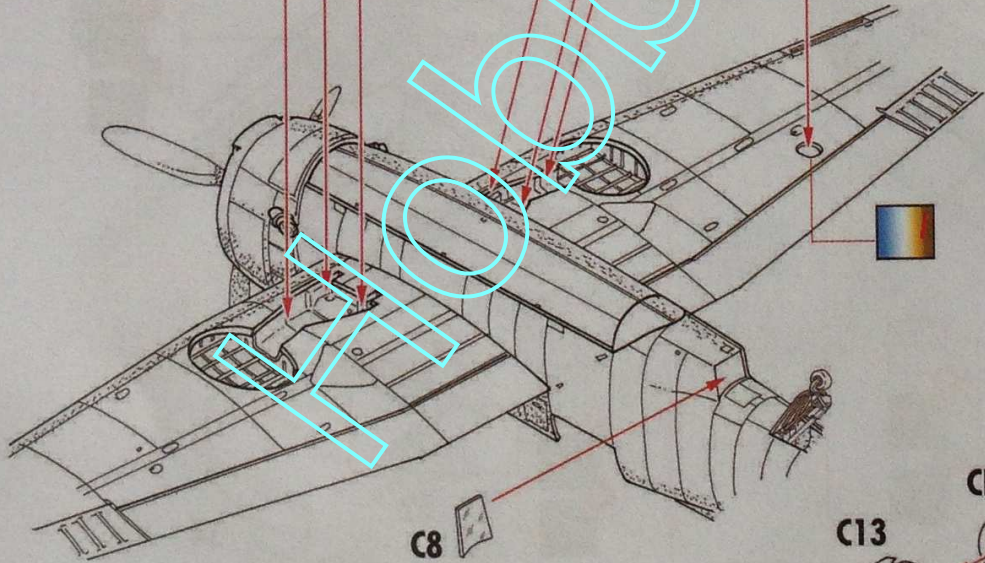

C8



37

38

31

31

8

G

CP

19

C13

19

?

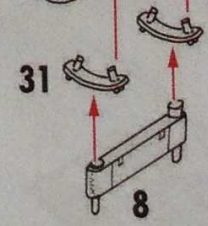
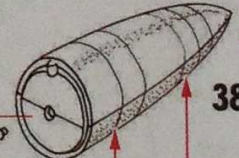
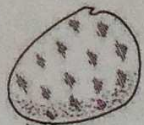



21

20

28

71

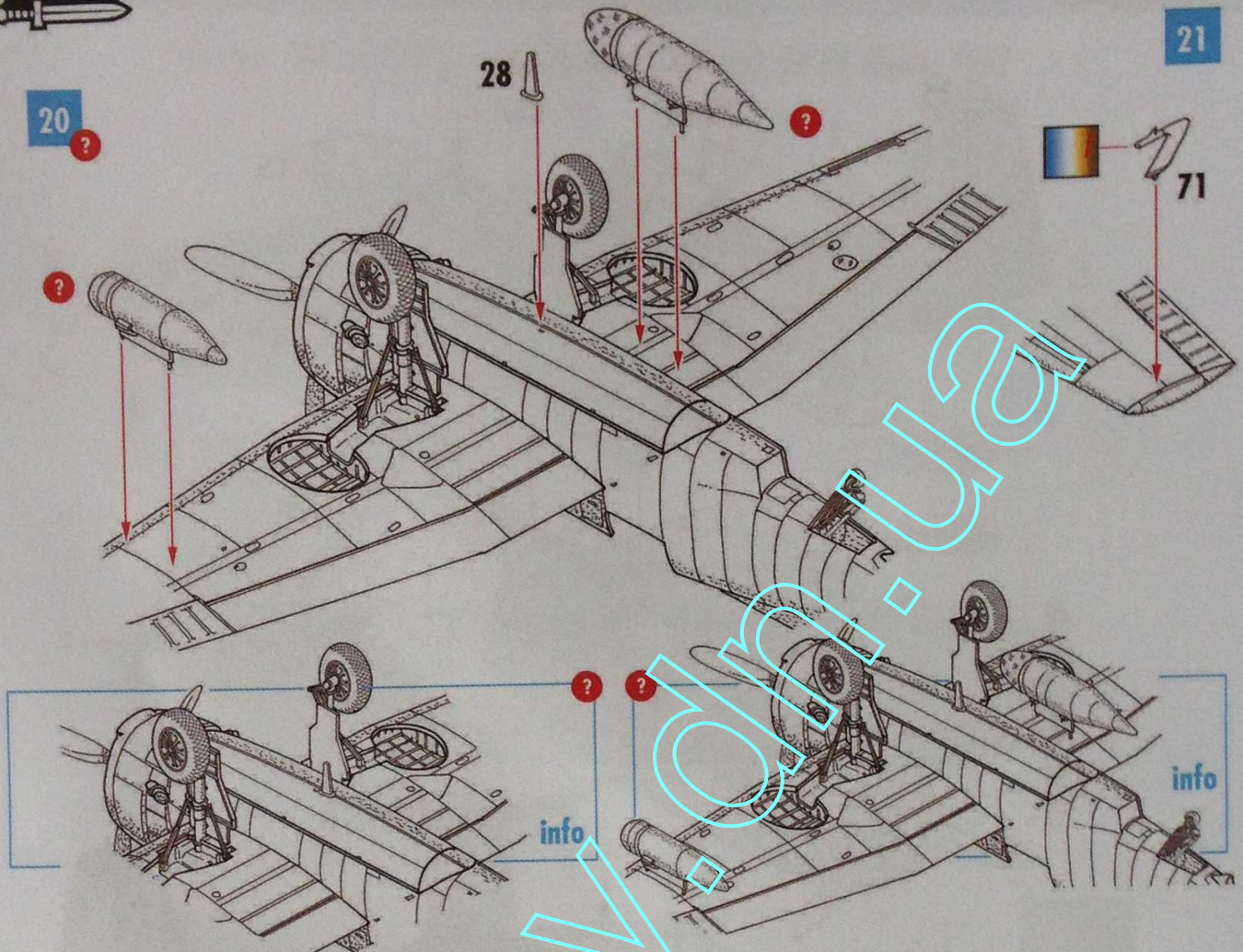

22

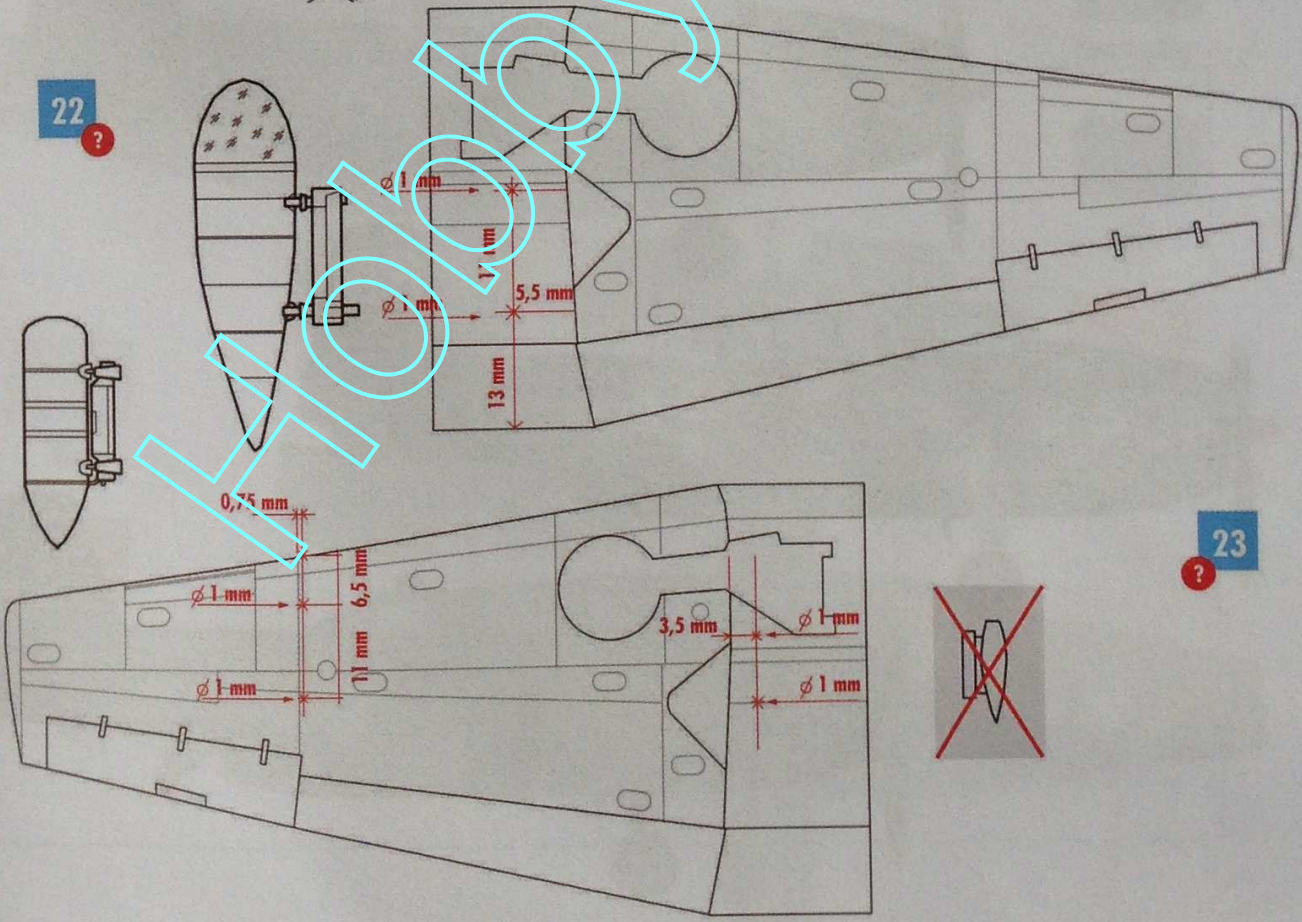

23



19

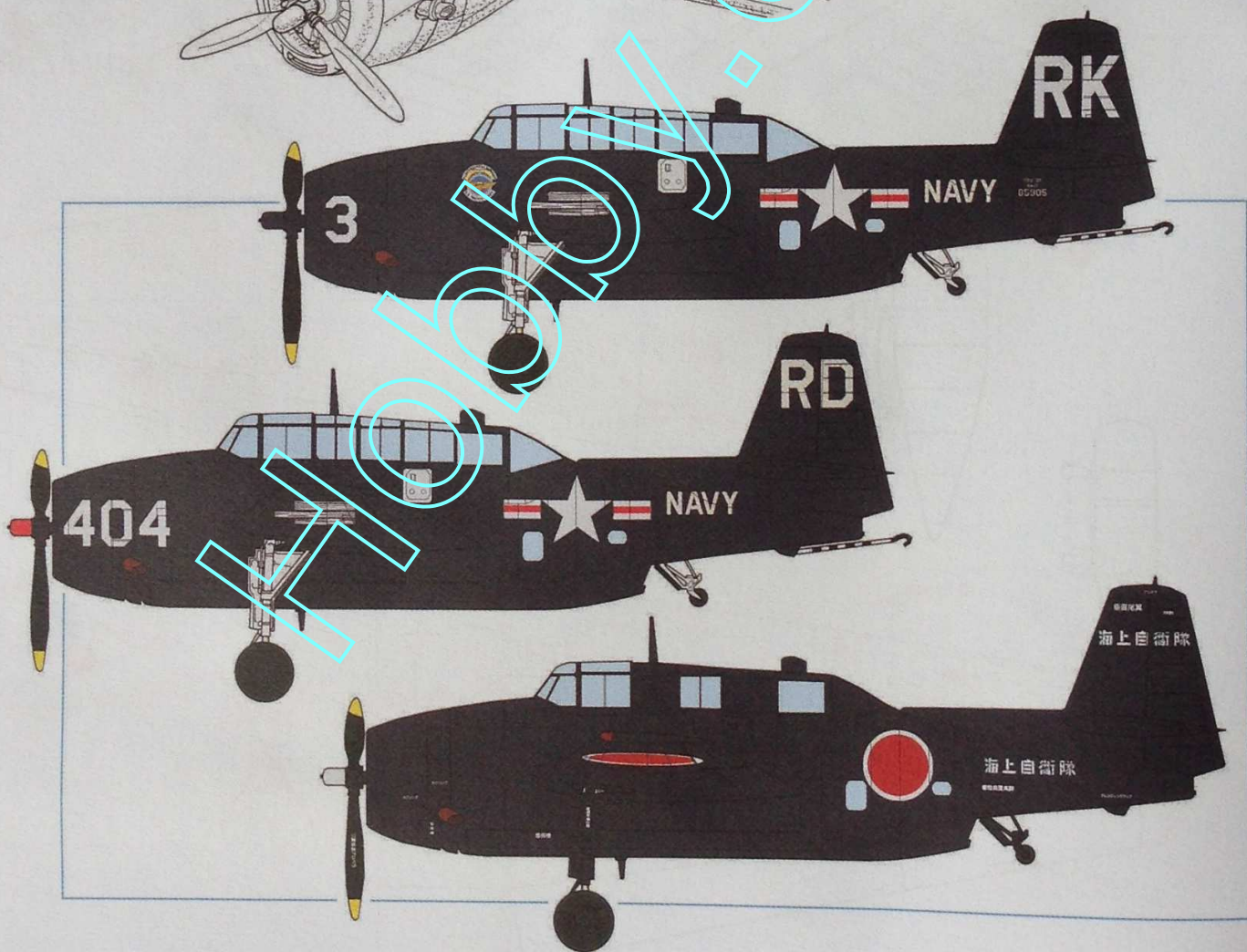
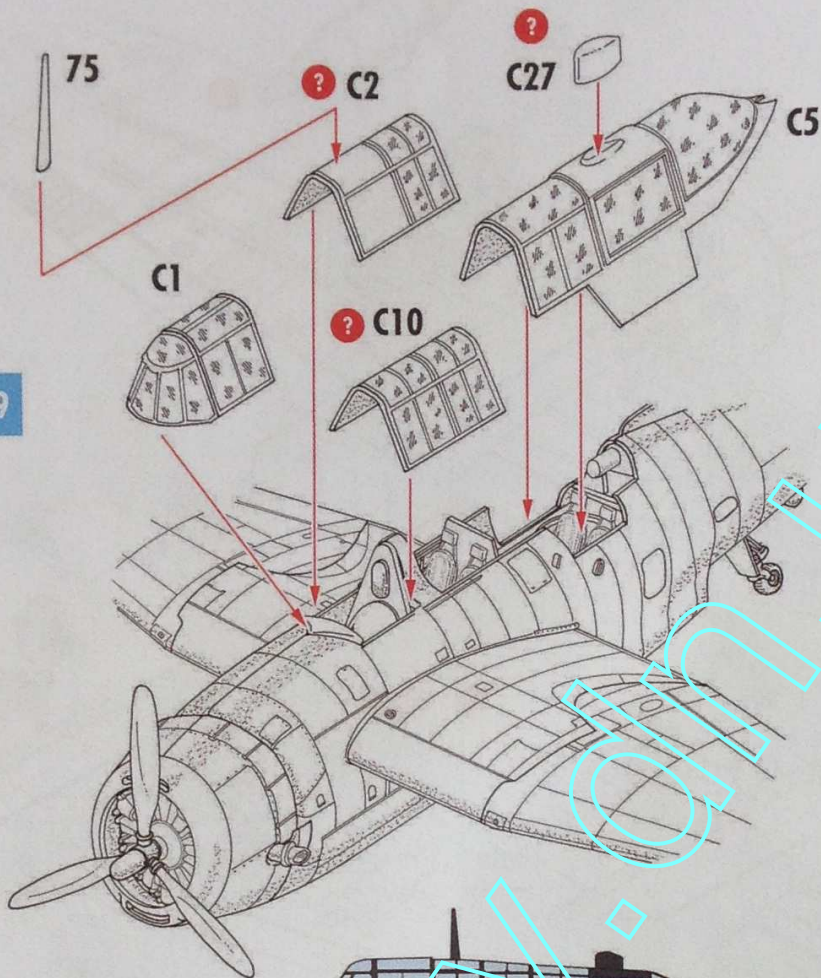

Avenger TBM-3R, COD (Carrier On board Delivery), VR-24, Naples, 1952

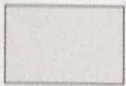
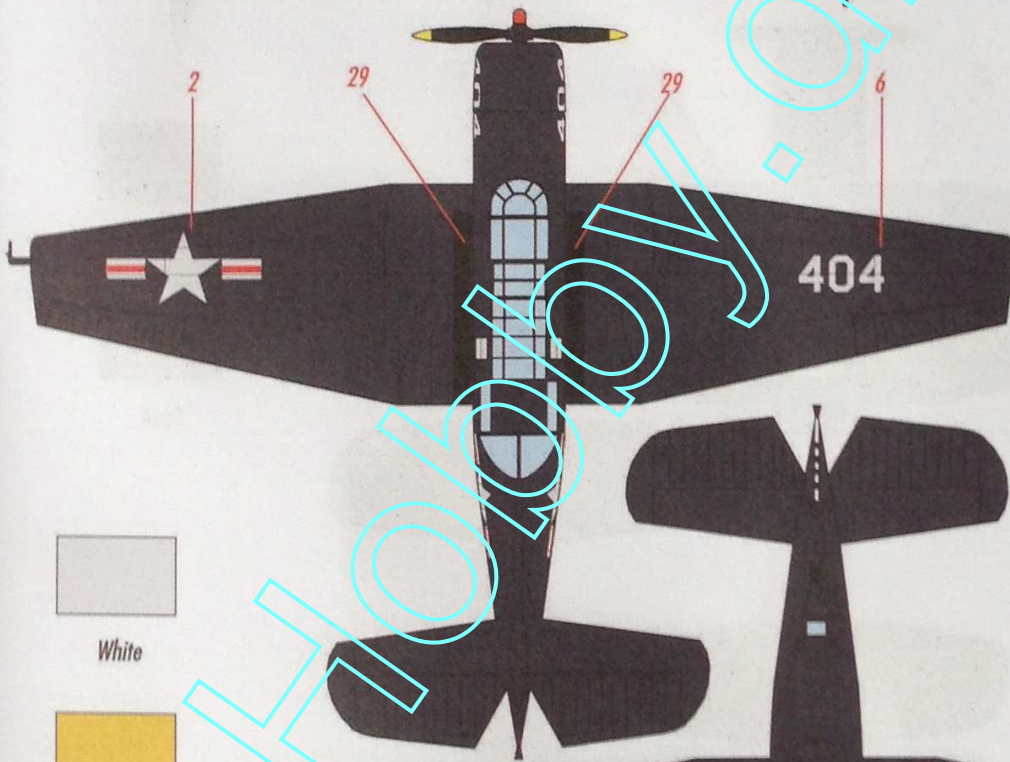
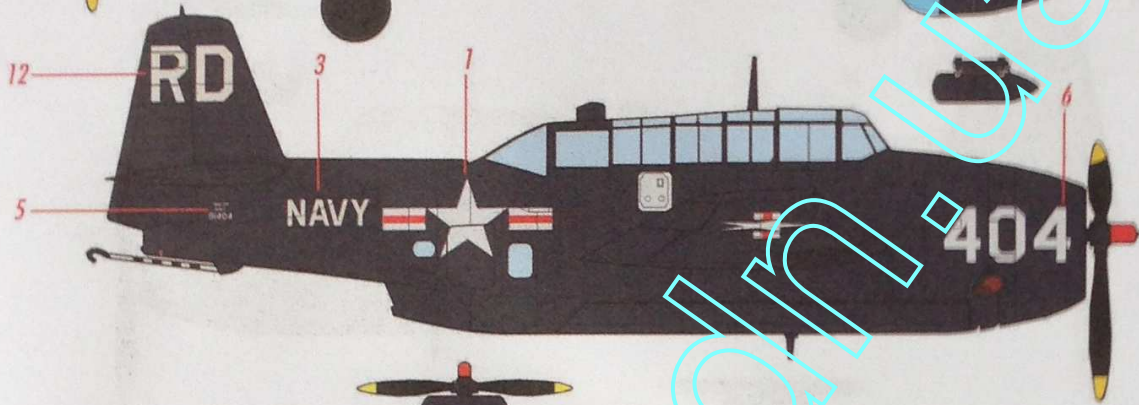
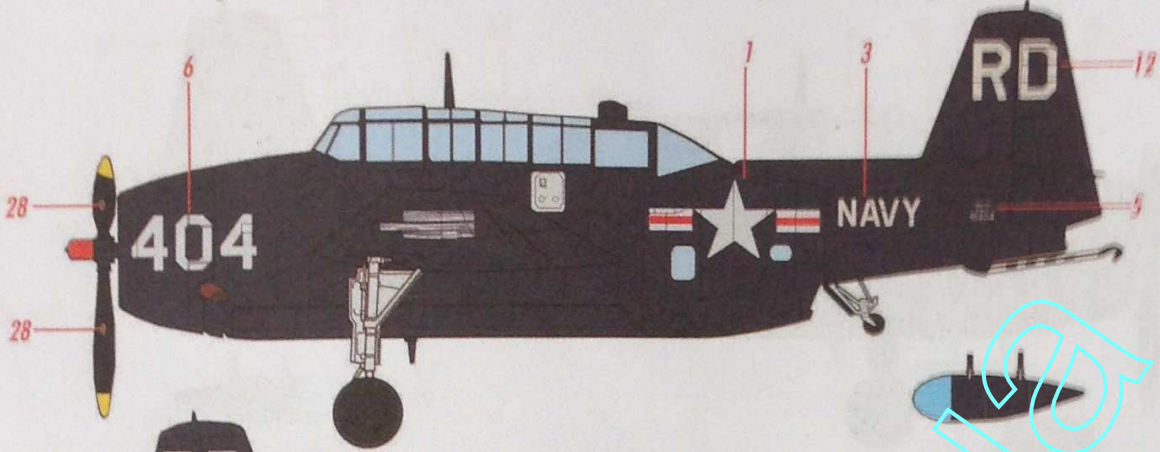

White



Yellow



Gloss Sea Blue



Black



Red

Avenger TBM-3R, J.M.S.D.F., 14 Kure-Saeki Kyouikutai

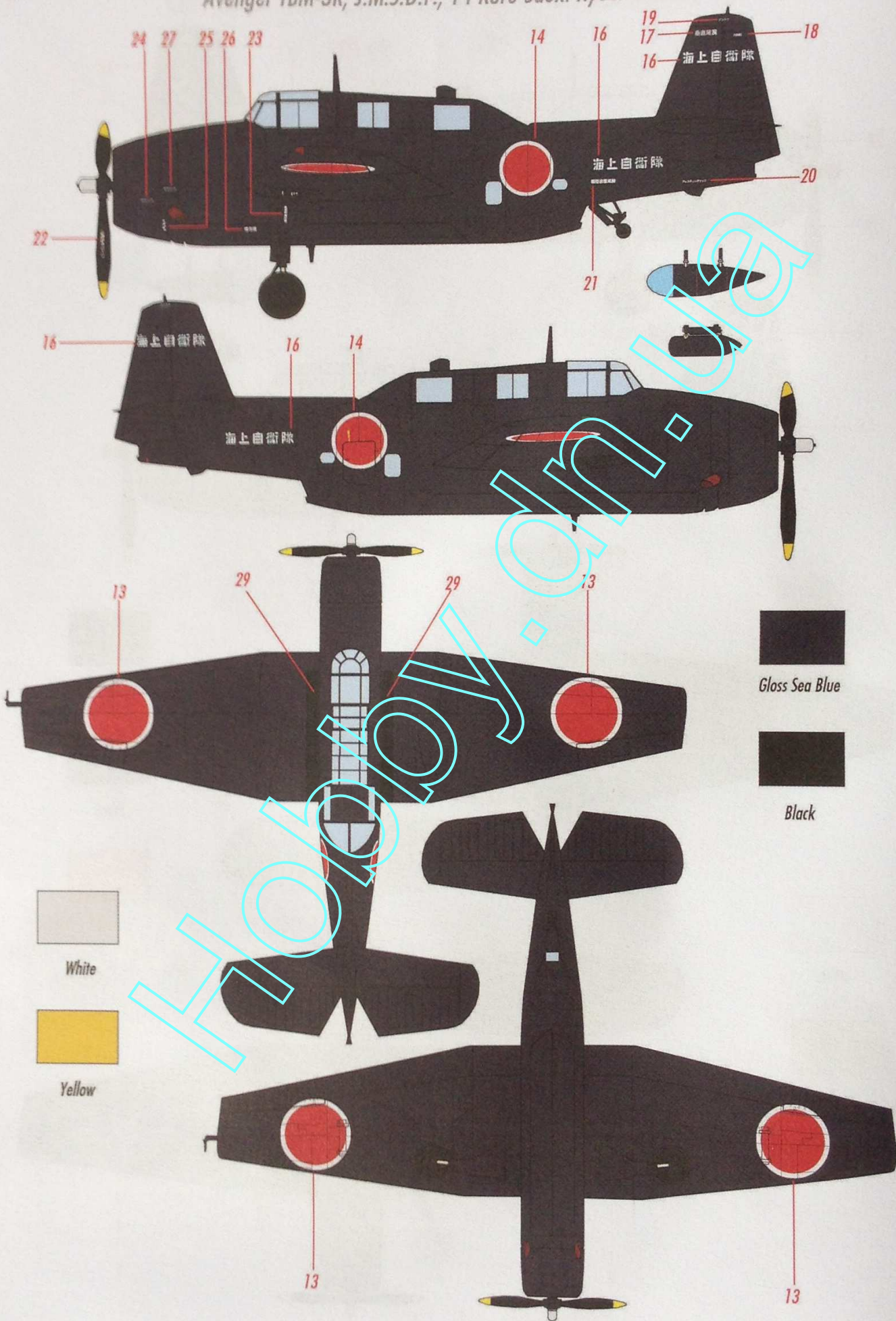

Grumman TBM-3R



Avenger TBM-3R, J.M.S.D.F., 14 Kure-Saeki Kyouikutai

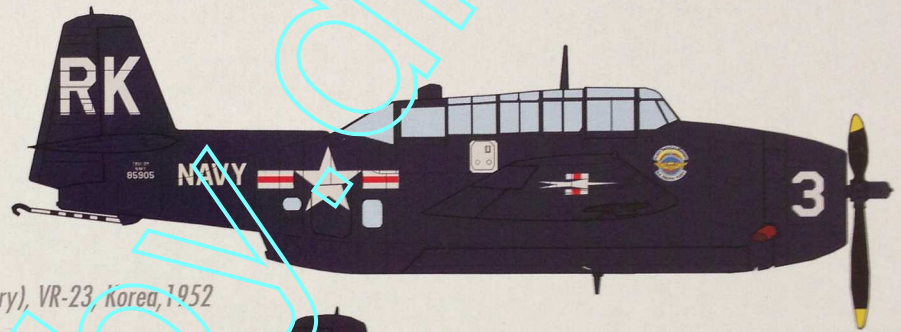

Avenger TBM-3R, COD (Carrier On board Delivery), VR-23, Korea, 1952

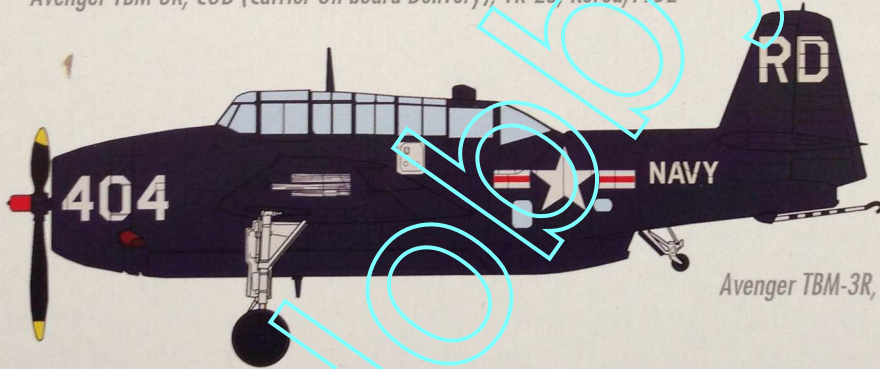

Avenger TBM-3R, COD (Carrier On board Delivery), VR-24, Naples, 1952

SW 72132 scale 1/72