



CAT.NO.BX72028

PLASTIC MODEL KIT LIMITED EDITION

SCALE:1/72

UA De Havilland DH-60 став родоначальником цілого сімейства літаків Moth, які зробили революцію в авіабудуванні Великобританії. Прототип літака DH-60 здійснив перший політ в лютому 1925 року. Остаточна версія літака була створена в 1927 році і випускалася в декількох модифікаціях. Всього було виготовлено 1640 літаків даного типу. DH-60 використовувався як туристичний, спортивний і як літак для далеких перельотів.

GB De Havilland DH-60 became an ancestor of the whole Moth airplanes family, which made a revolution in aircraft building of Great Britain. DH-60 prototype made its maiden flight in February 1925. The final version of the airplane was approved in 1927 and was produced in some modifications. 1640 airplanes of given type were produced in total. DH-60 was used as a tourist and sports airplane and as an airplane for a long-distance flight.

5359¹ 5359

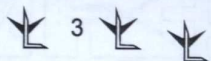

5359² 5359 5359

DH-60X Amphibian



ДЕКАЛІ ДЛЯ ОДНОГО ВАРІАНТА
(Велика Британія)

DECALS FOR ONE VERSION
(Great Britain)

 ДЕТАЛІ НЕ ВИКОРИСТОВУЮТЬСЯ
 PARTS NOT USED

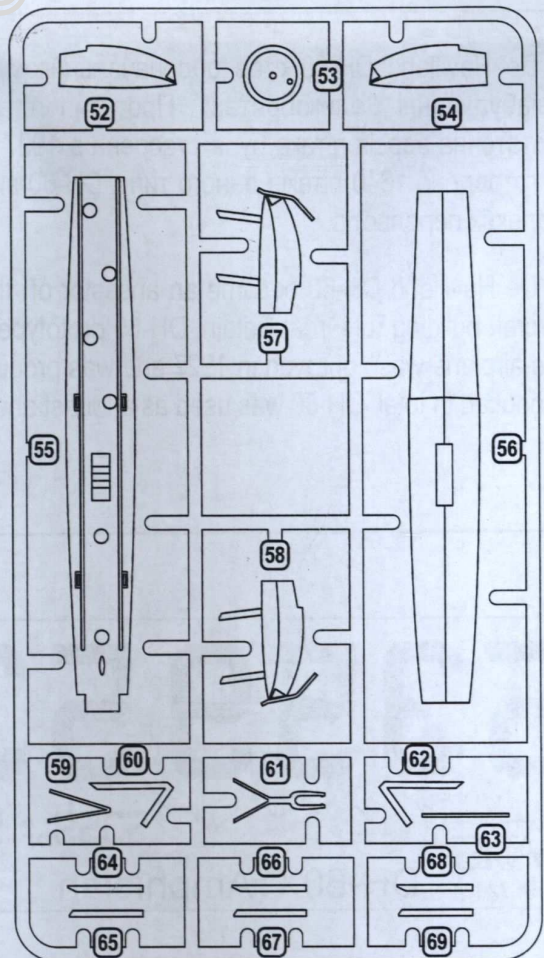
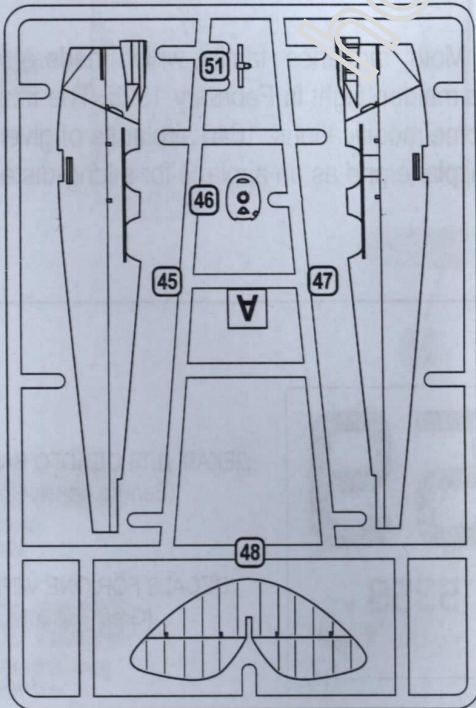
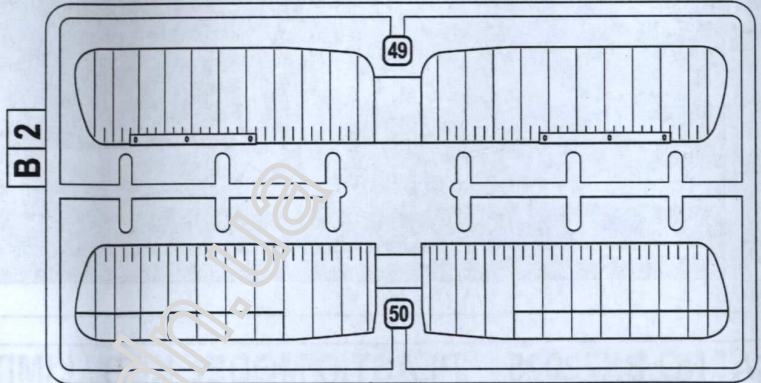
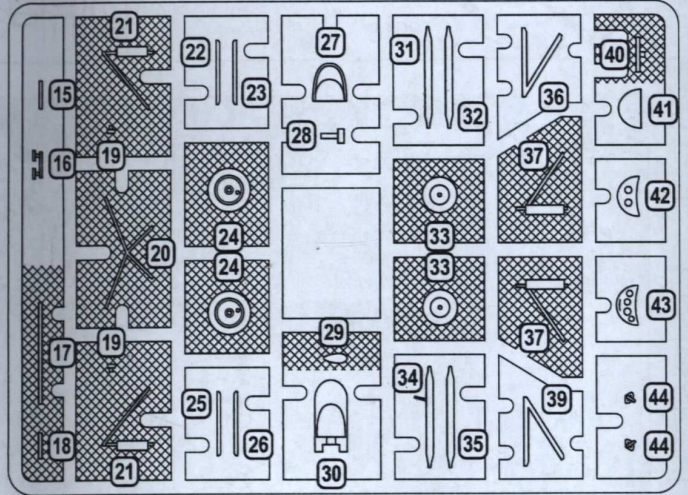
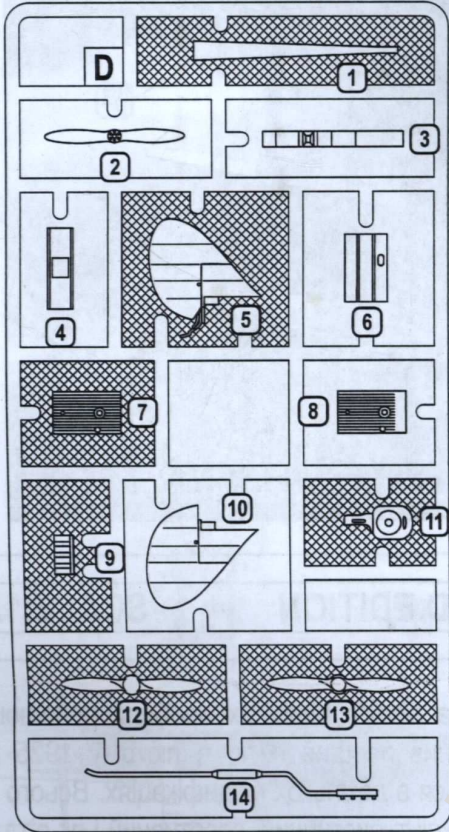
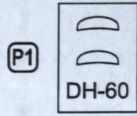

1

ЕТАПИ СКЛАДАННЯ
STAGES OF
ASSEMBLY

2X

КІЛЬКІСТЬ
ОПЕРАЦІЙ(ДЕТАЛЕЙ)
QUANTITY OF
OPERATIONS(PARTS)

1

НОМЕР ДЕТАЛІ
NUMBER
PARTS

AB

ФАРБУВАТИ
TO PAINT



КЛЕЇТИ
GLUE



НА ВИБІР
OPTIONAL



НЕ КЛЕЇТИ
DON'T
GLUE

1

НАНЕСТИ
ДЕКАЛЬ
APPLY DECALS



ВИГОТОВИТИ
ДЕТАЛЬ
TO MAKE A DETAIL



УСНУТИ НОЖЕМ
DETACH WITH
KNIFE



ЗІГНУТИ
TO BEND



ВИКОНАТИ
ОТВІР
MAKE A HOLE

1 3 15 16 27 30

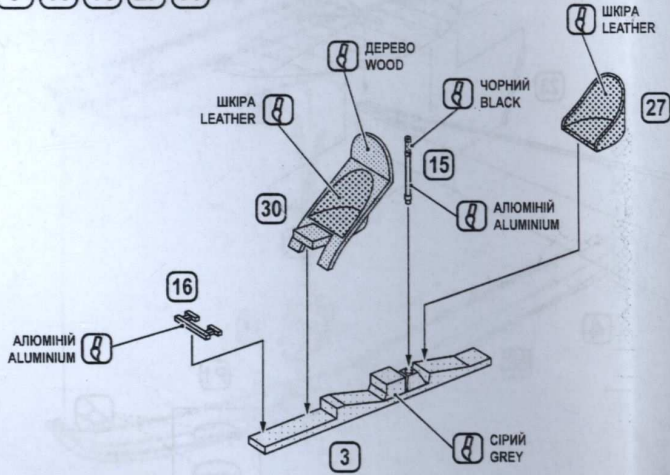

2 2 28 46

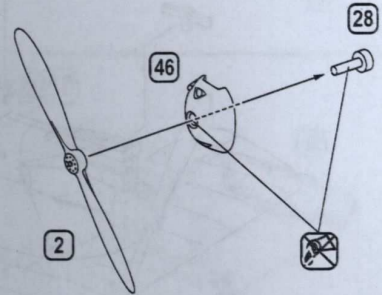

3 2X 44 45

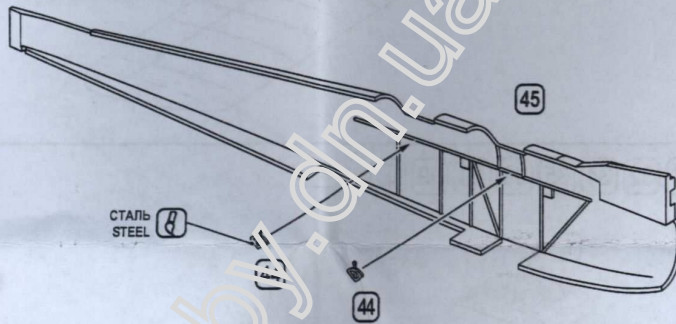

4 4 41 42 43 47 1 2 3

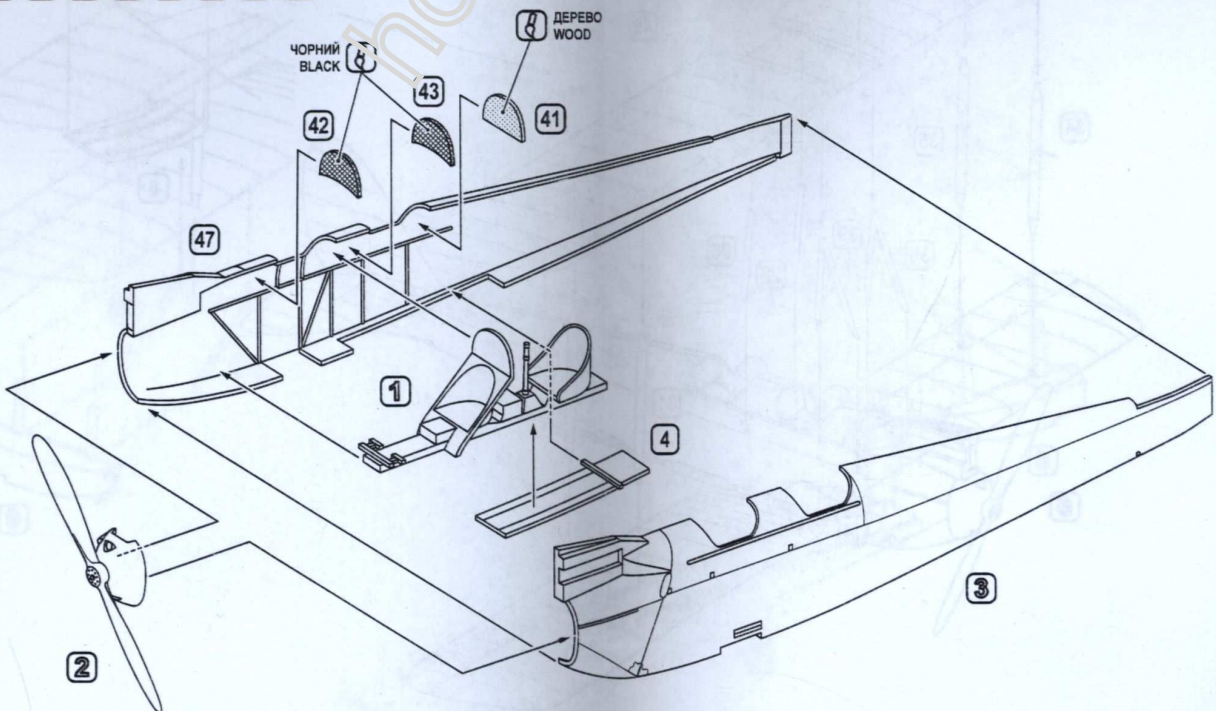

5 10 23 26 48 50 51 2X P1 4

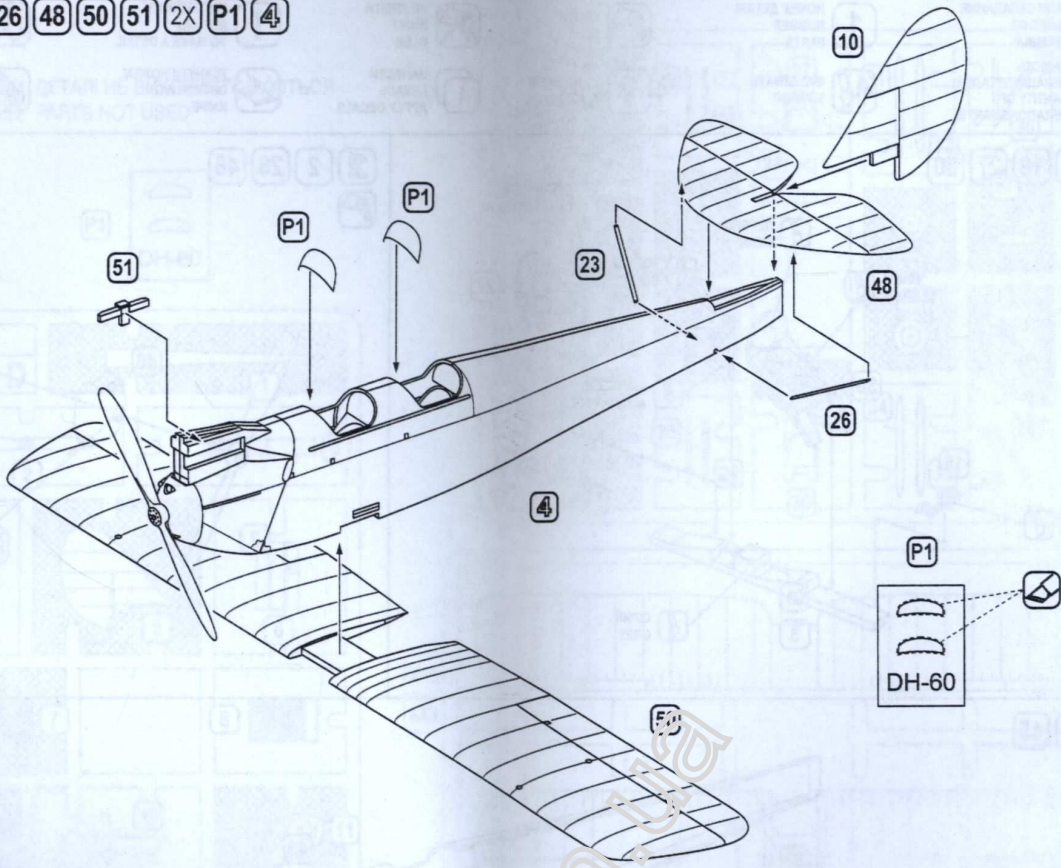

6 6 8 14 22 25 31 32 34 35 36 39 49 5

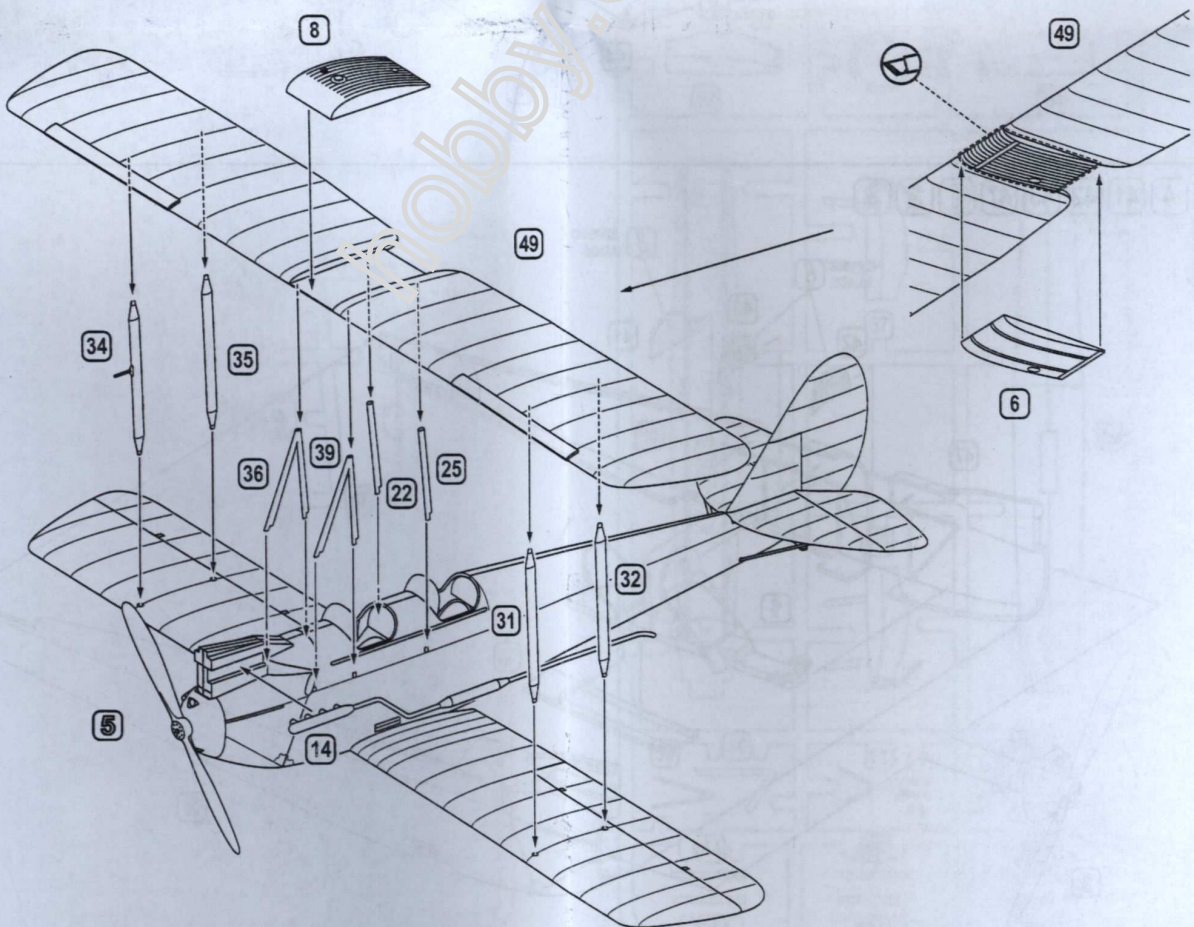

7 53 55 56 61

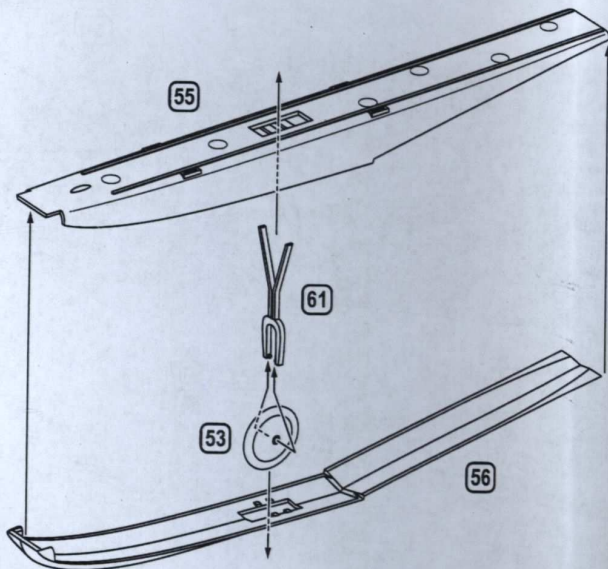

8 54 58

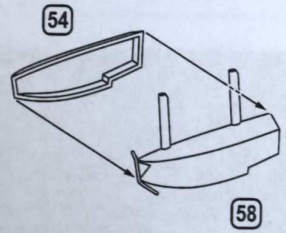

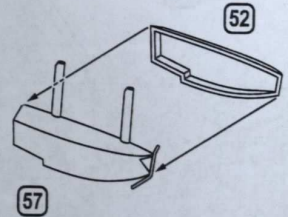

9 52 57

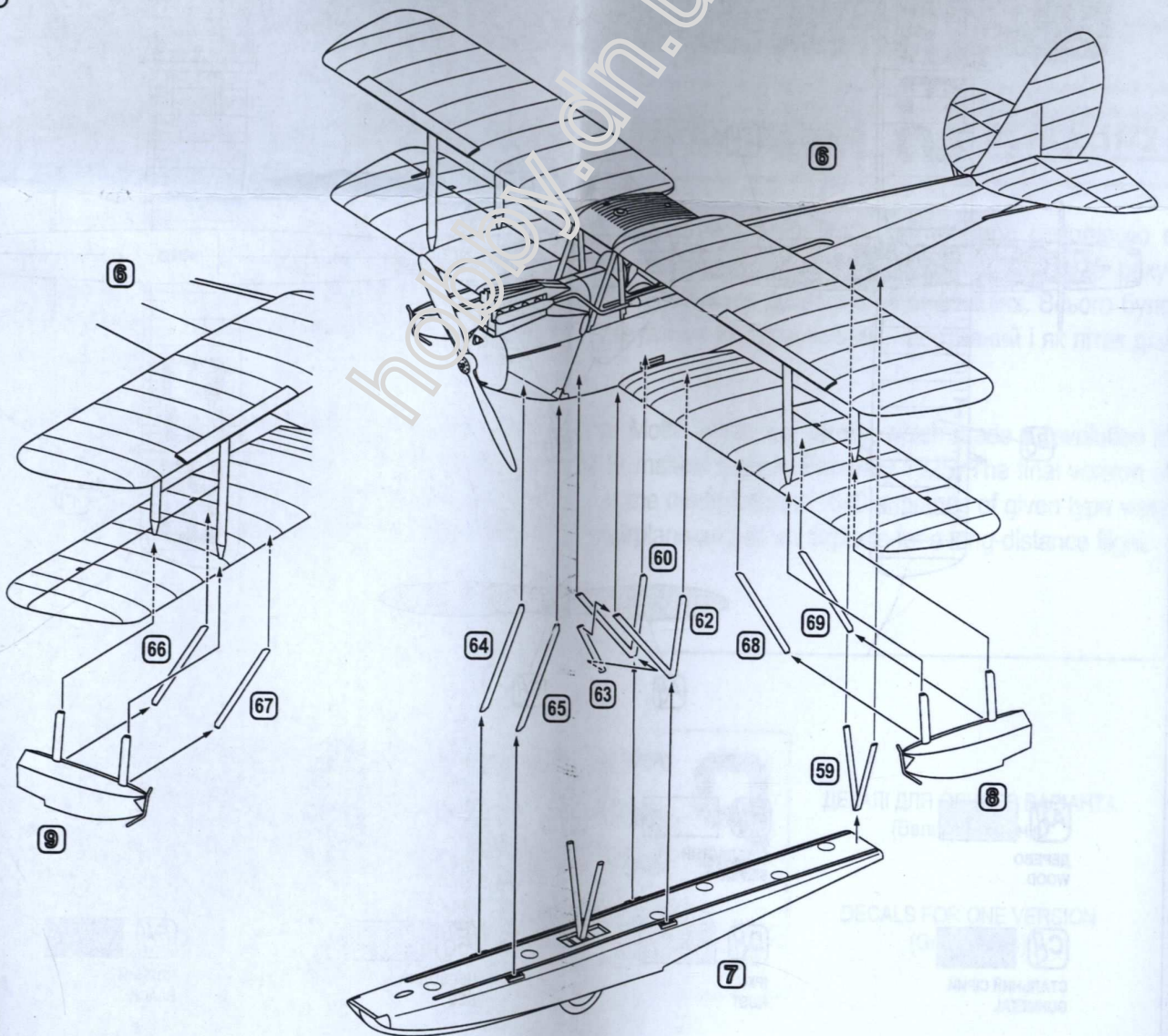

10 59 60 62 63 64 65 66 67 68 69 6 7 8 9

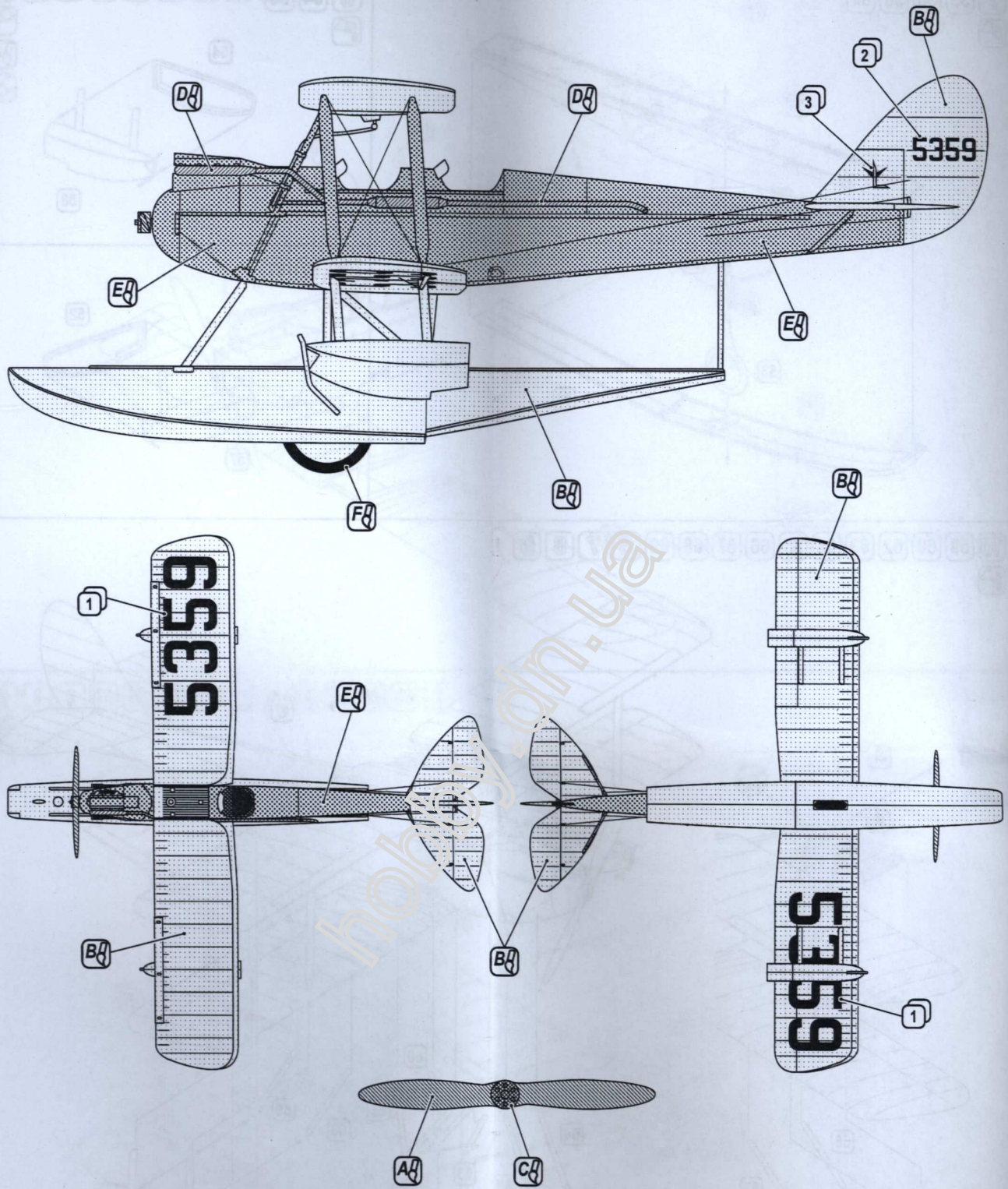



A 
 ДЕРЕВО
 WOOD

B 
 СРІБЛЯСТИЙ
 SILVER

C 
 СТАЛЬНИЙ СІРИЙ
 GUNMETAL

D 
 ІРЖА
 RUST

E 
 ЧЕРВОНИЙ
 RED

F 
 ЧОРНИЙ
 BLACK