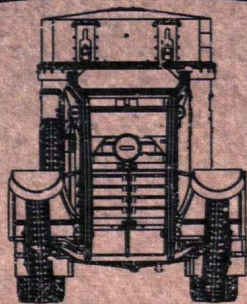

ISTRUZIONI DI MONTAGGIO E COLORAZIONE COPPER STATE MODELS		ARRICCHITE CON PROFILI E FOTOGRAFIE RIGA, LETTONIA
--	---	---

ART. 35008

Scala 1 a 35

# AUTOBLINDATA IZ MODIFICATA

(con versioni coloniali e catturate)

**Geheim!**



---

IMPRIMATUR  
RIGA, SEPTEMBER MMXXI

## Important Notes

- Read the instructions carefully before starting the assembly.
- Use glue intended for plastic models.
- Choking hazard. Keep small parts and plastic bags away from children.
- Always wear protective eyewear when cutting and a protective mask when painting, glueing and sanding.
- Use paints designed and suitable for plastic model kitsets.

## Symbols Reference

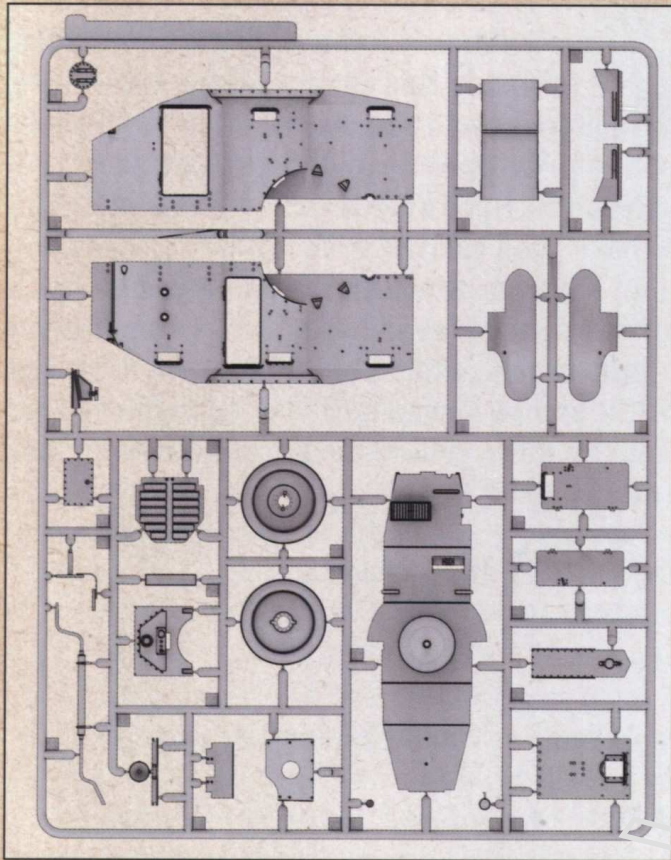
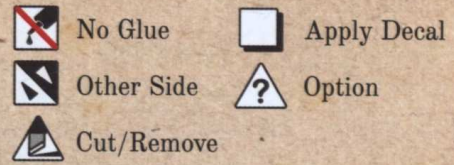

Fig. 1. Runner A

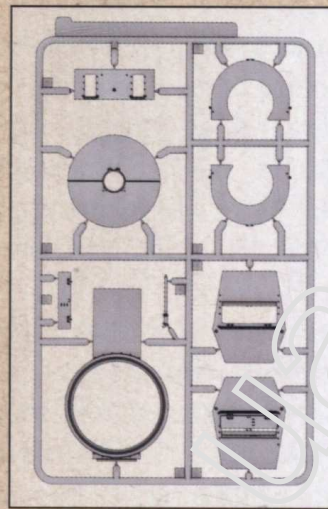

Fig. 2. Runner C

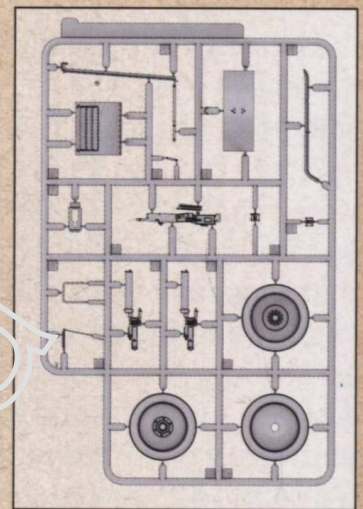

Fig. 3. Runner D, 2 pcs

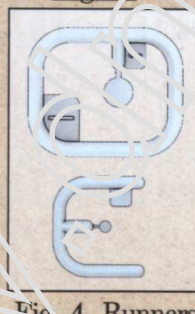

Fig. 4. Runners E and I

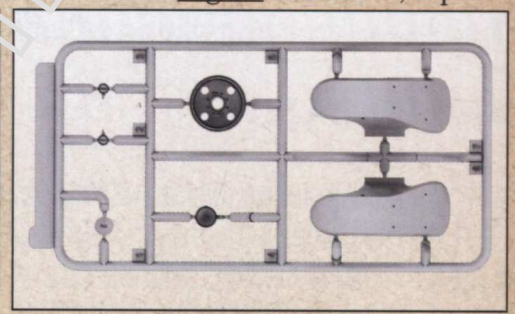

Fig. 5. Runner F

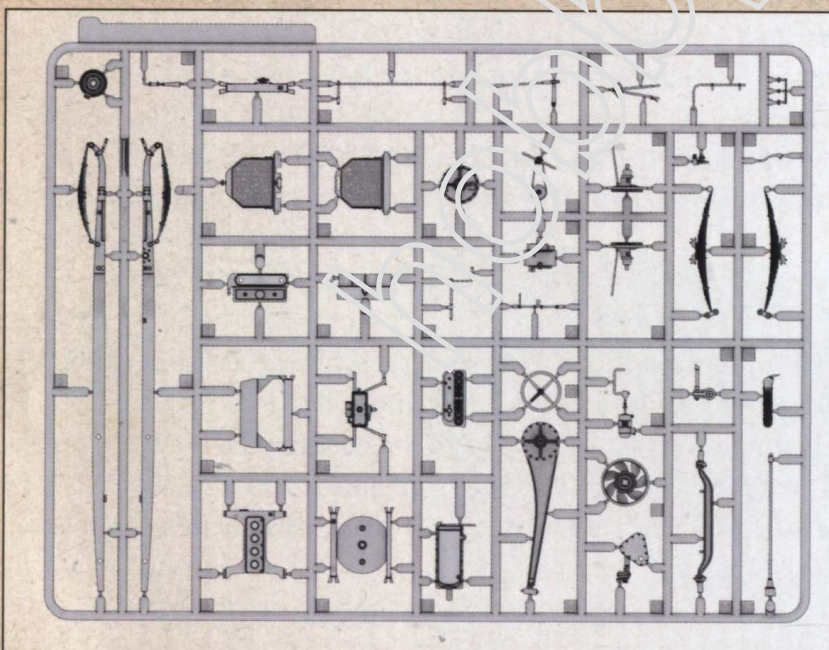

Fig. 7. Runner B

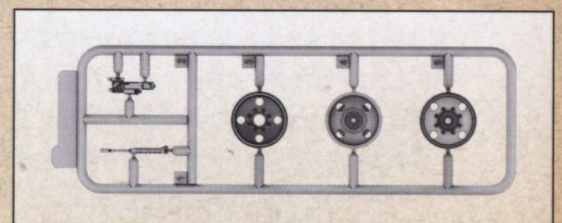

Fig. 6. Runner G

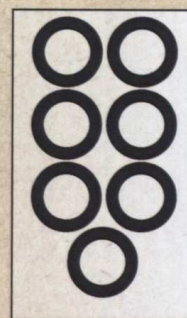

Fig. 8. Rubber wheels, 7 pcs

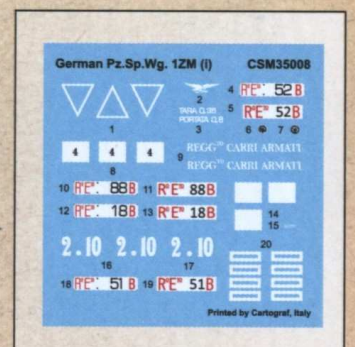
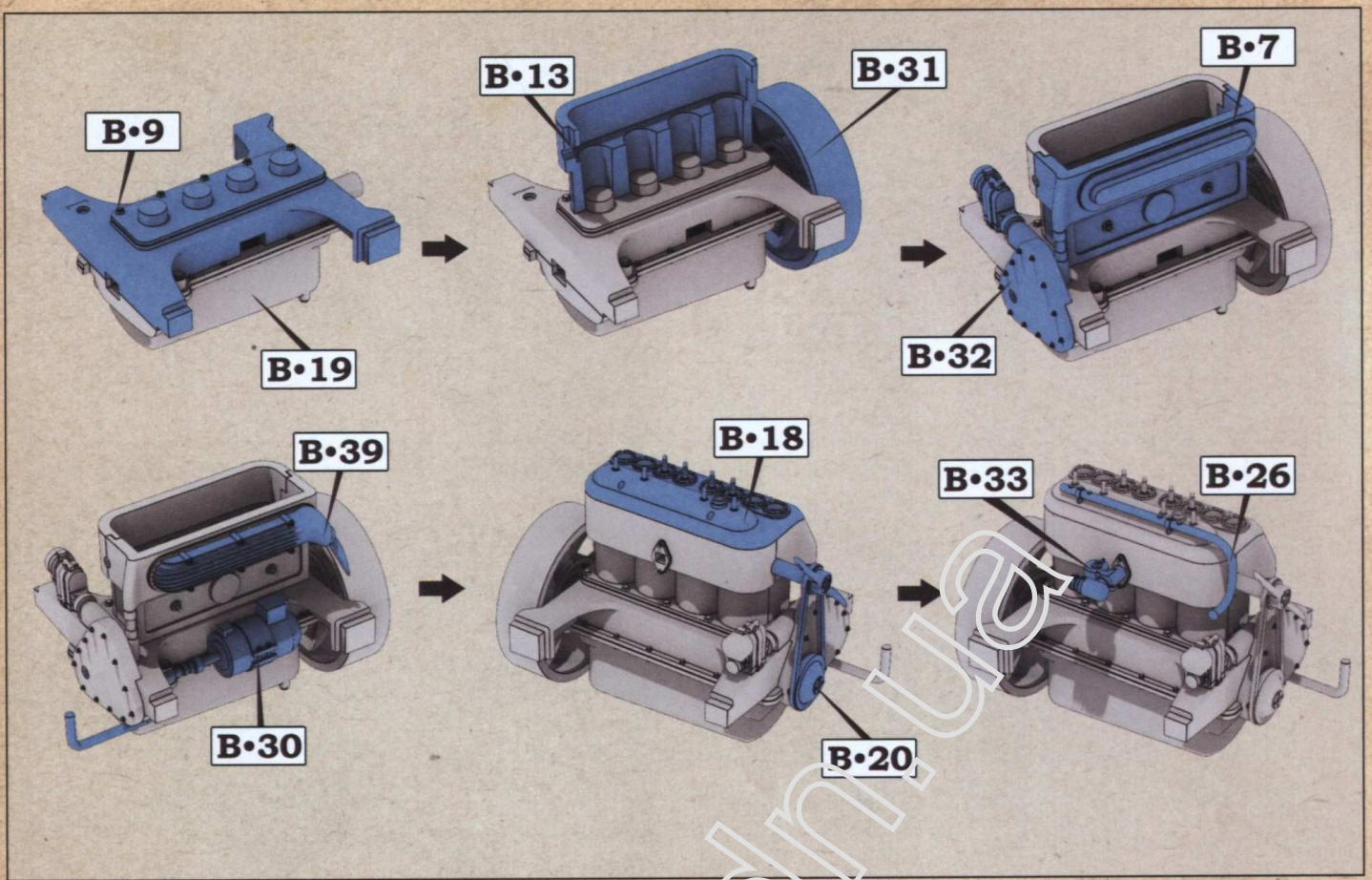

Fig. 9. Decals

## Colour numbers

<b>1</b> Burnt metal (exhaust)	<b>4</b> Steel	<b>7</b> Wood	<b>10</b> Gun metal	<b>13</b> Grey green	<b>16</b> Darl yellow
<b>2</b> Aluminum	<b>5</b> Black	<b>8</b> Leather	<b>11</b> Green	<b>14</b> Dark green	<b>17</b> Brown (maroon)
<b>3</b> Copper	<b>6</b> White	<b>9</b> Brass	<b>12</b> Light Green	<b>15</b> Bakelite	<b>18</b> Yellow ochre



Step 1. Engine assembly

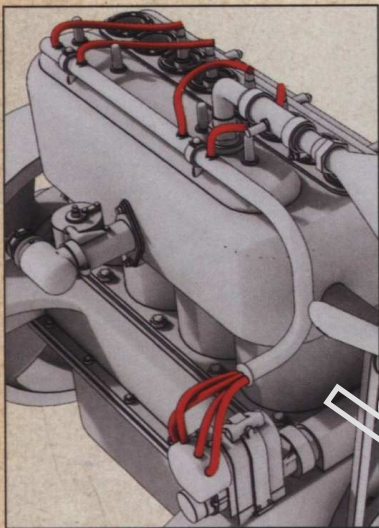

Fig 10. Engine wiring

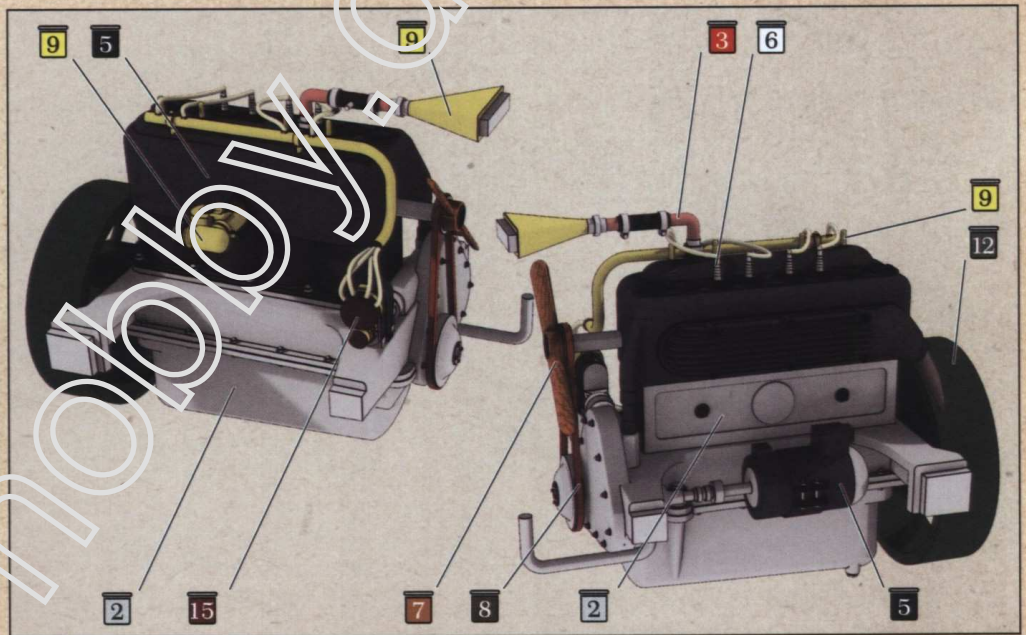
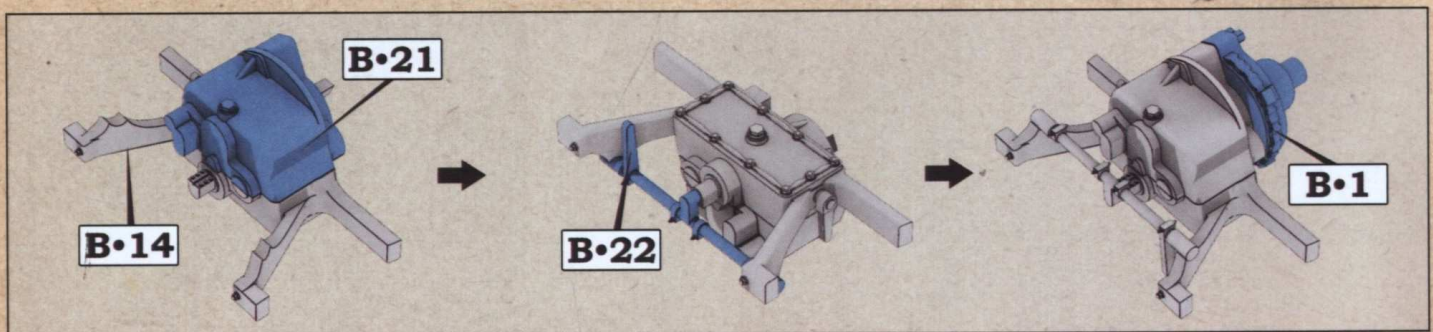
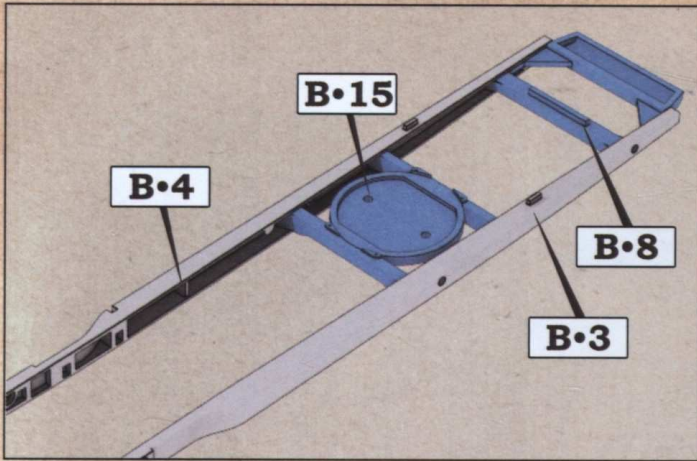

Fig 11. Engine assembly



Step 2. Gearbox assembly



Step 3. Installing both side rails and the cross members

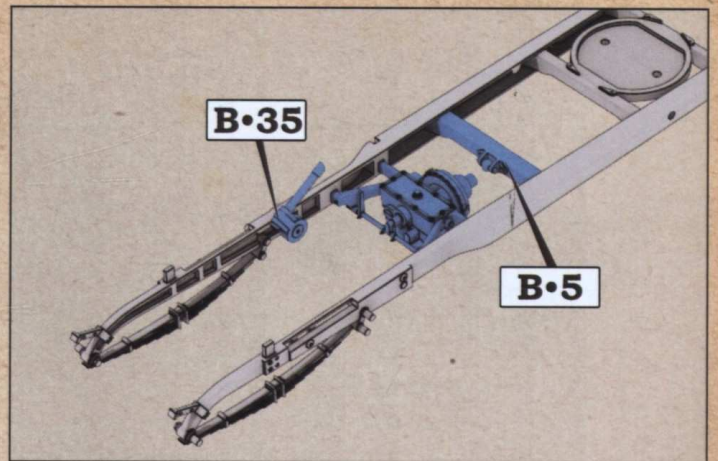

Step 4. Installing the steering gear, gearbox and other

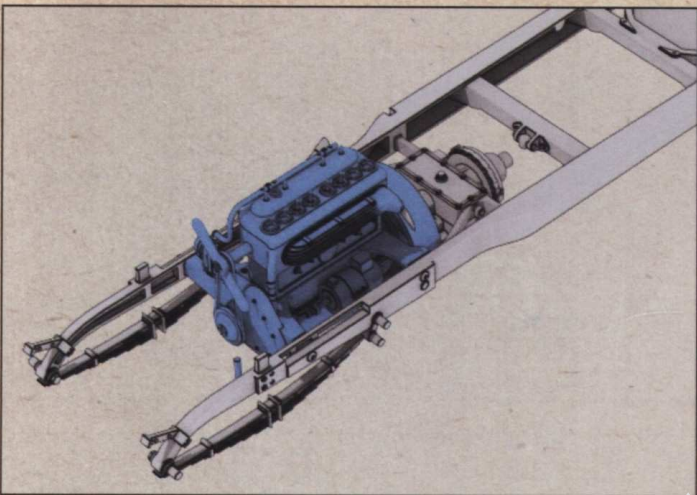

Step 5. Installing the engine

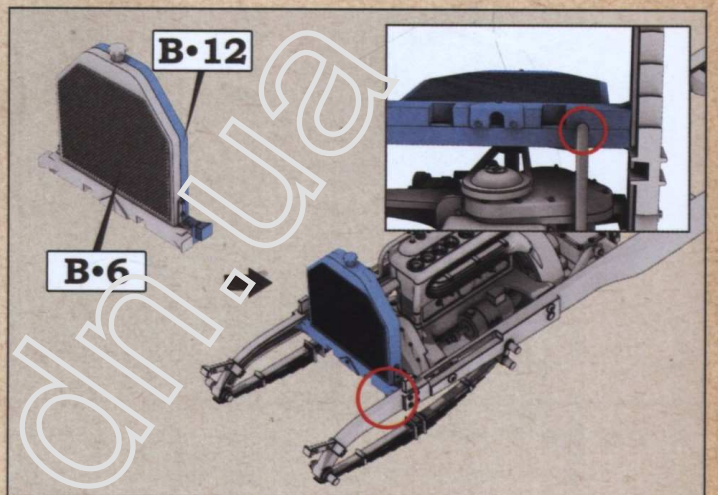

Step 6. Installing the radiator

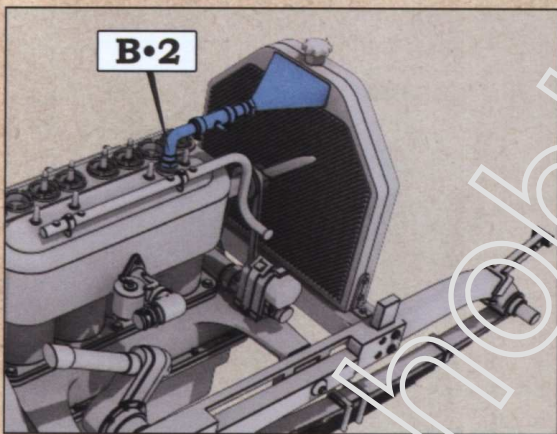

Step 7. Installation of the radiator pipe

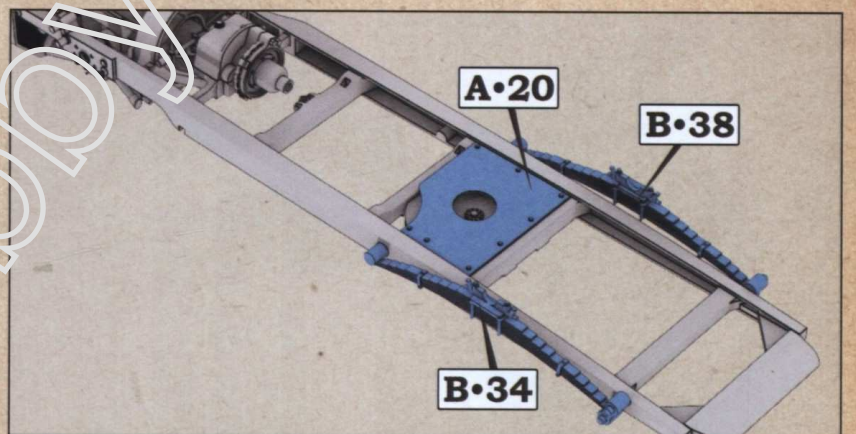

Step 8. Installation of the rear leaf springs and fuel tank protection

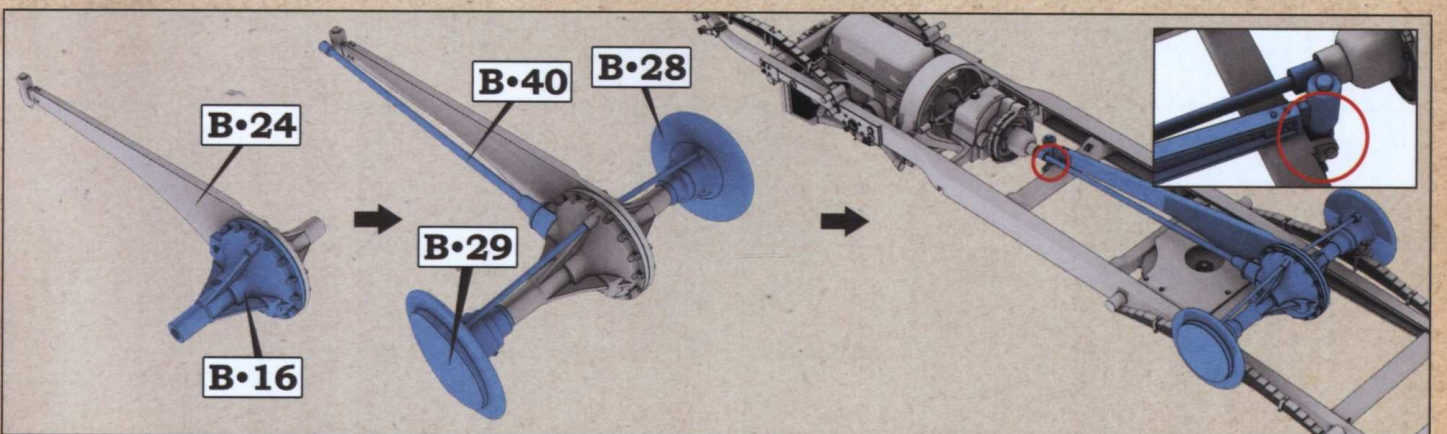

Step 9. Assembling and installation of the rear axle

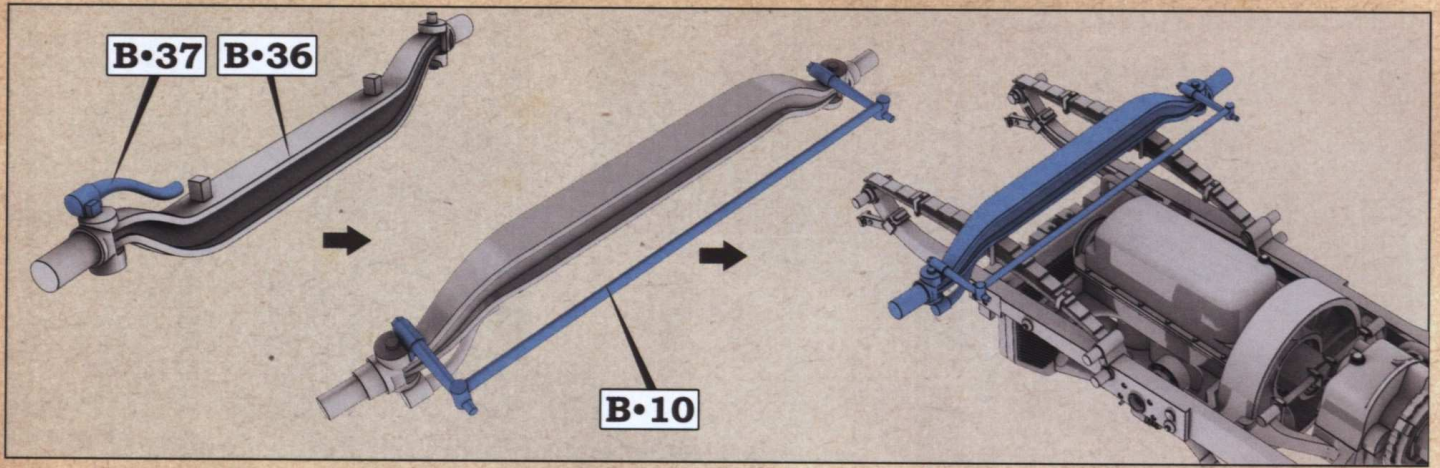

Step 10. Assembling and installation of the front axle

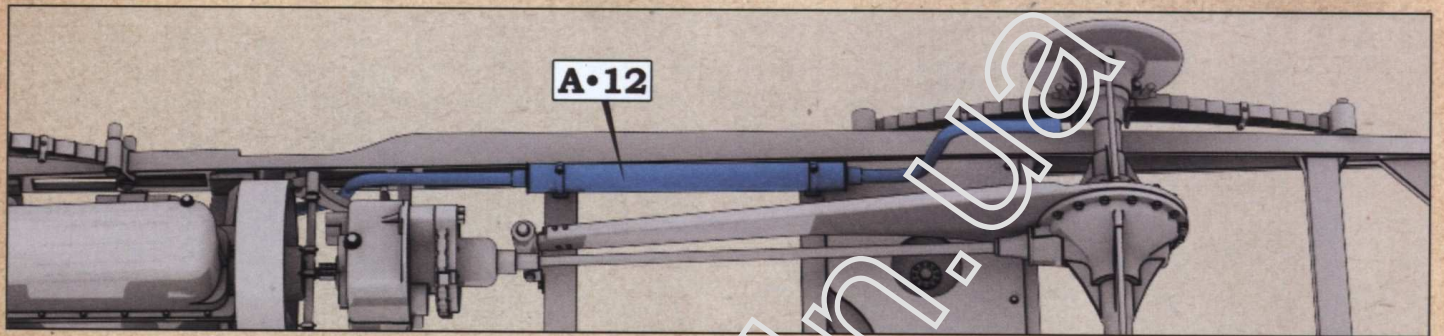

Step 11. Installation of the exhaust pipe with muffler

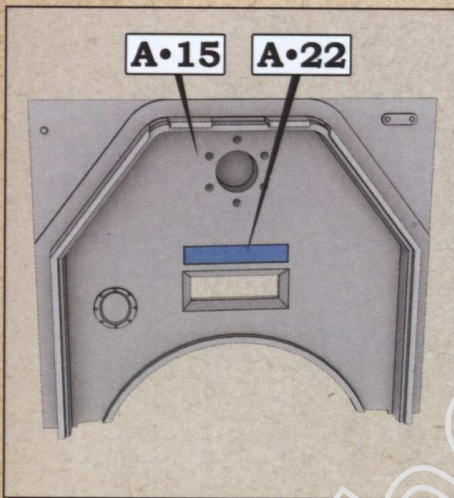

Step 12. Filling the hole

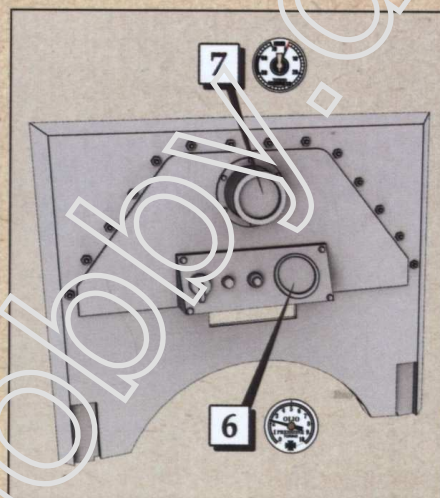

Step 13. Applying the decals

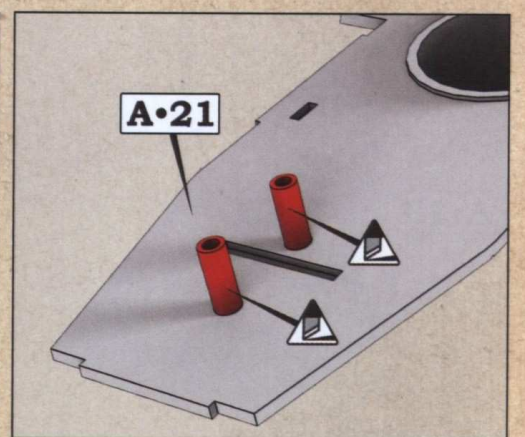

Step 14. Remove the pins

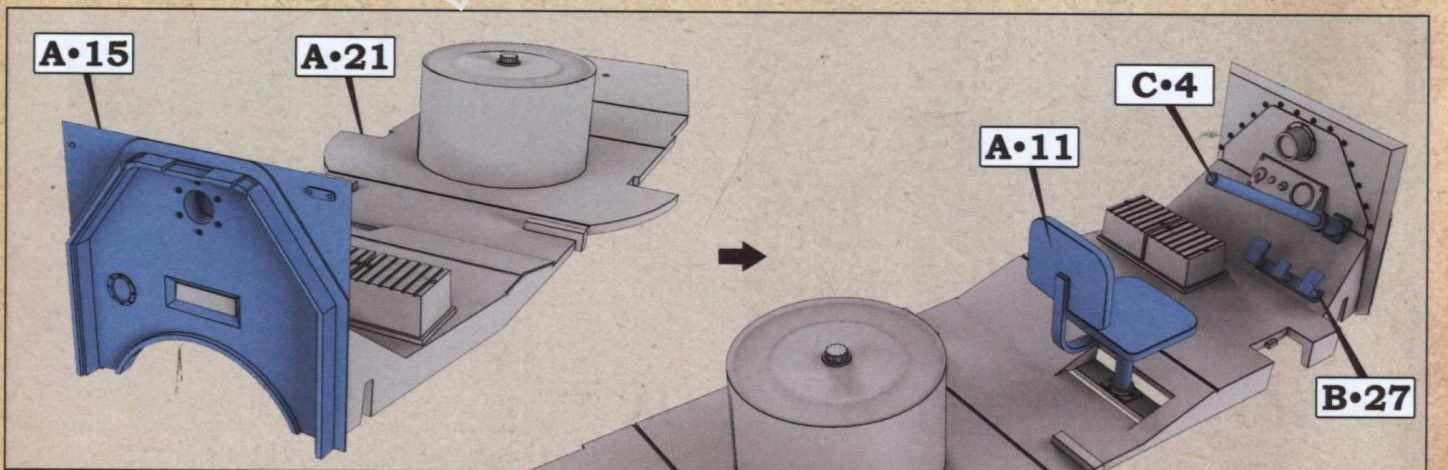

Step 15. Assembling the interior parts

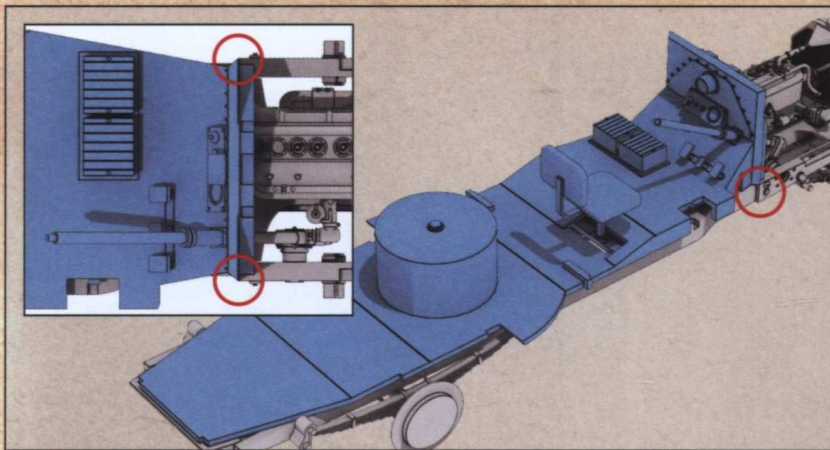

Step 16. Installing the floor with the interior. **Check the alignment**

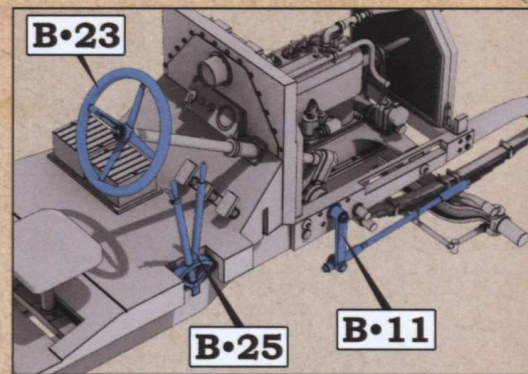

Step 17. Installation of the gear and handbrake levers, steering wheel and the steering arm

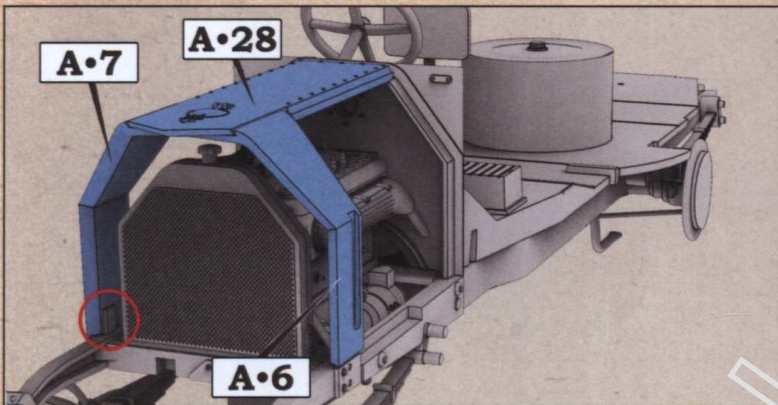

Step 18. Installation of the radiator and engine armour

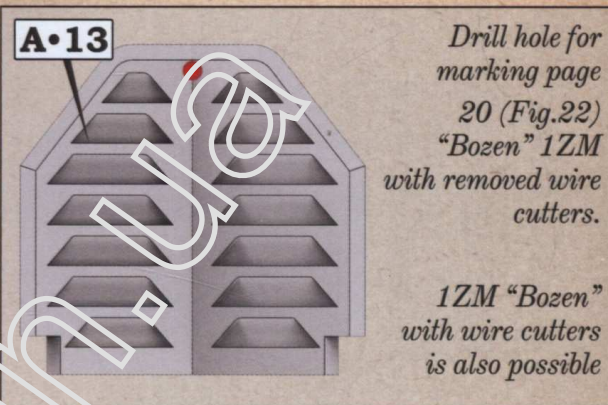

Step 19. Radiator armour additional actions

Drill hole for marking page 20 (Fig.22) "Bozen" 1ZM with removed wire cutters.

1ZM "Bozen" with wire cutters is also possible

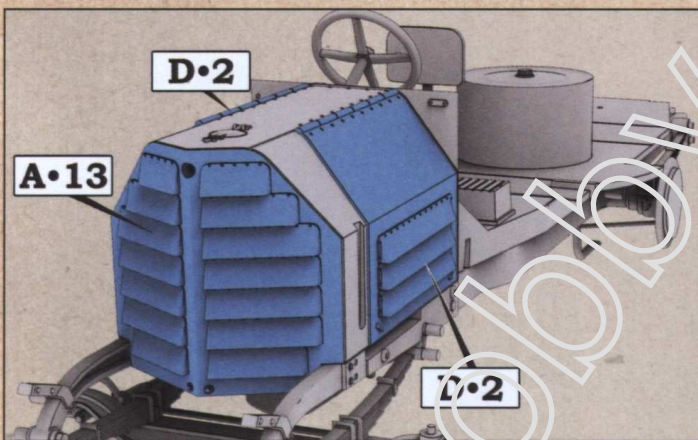

Step 20. Installation of the front and side radiator armour

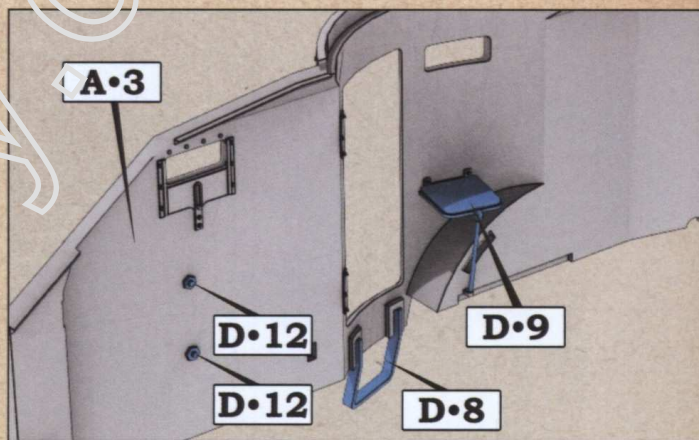

Step 21. Starboard armour interior parts

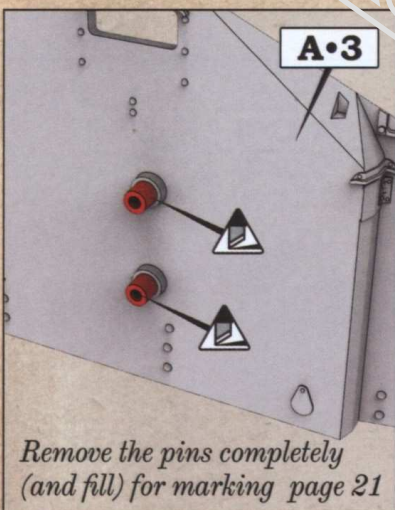

Remove the pins completely (and fill) for marking page 21

Step 22. Remove the top of the pins

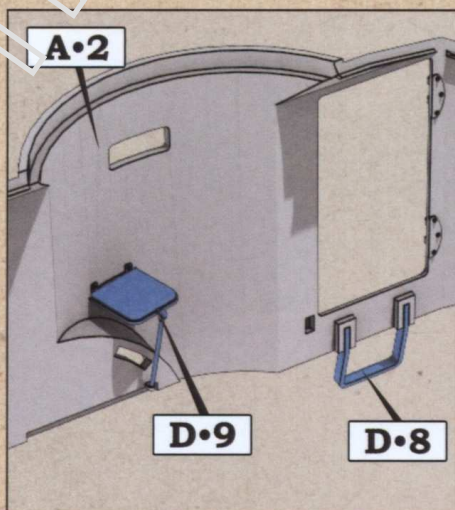

Step 23. Port armour interior parts

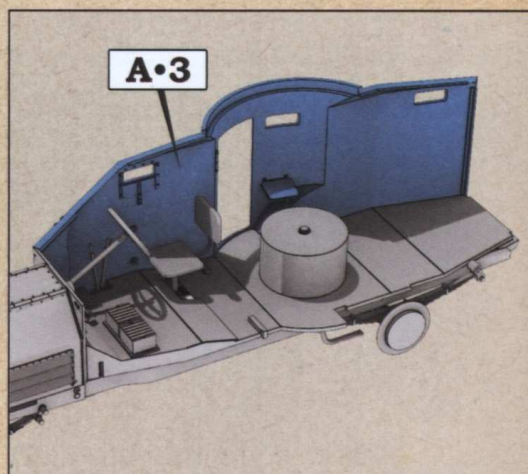

Step 24. Installation of the starboard armoured superstructure wall

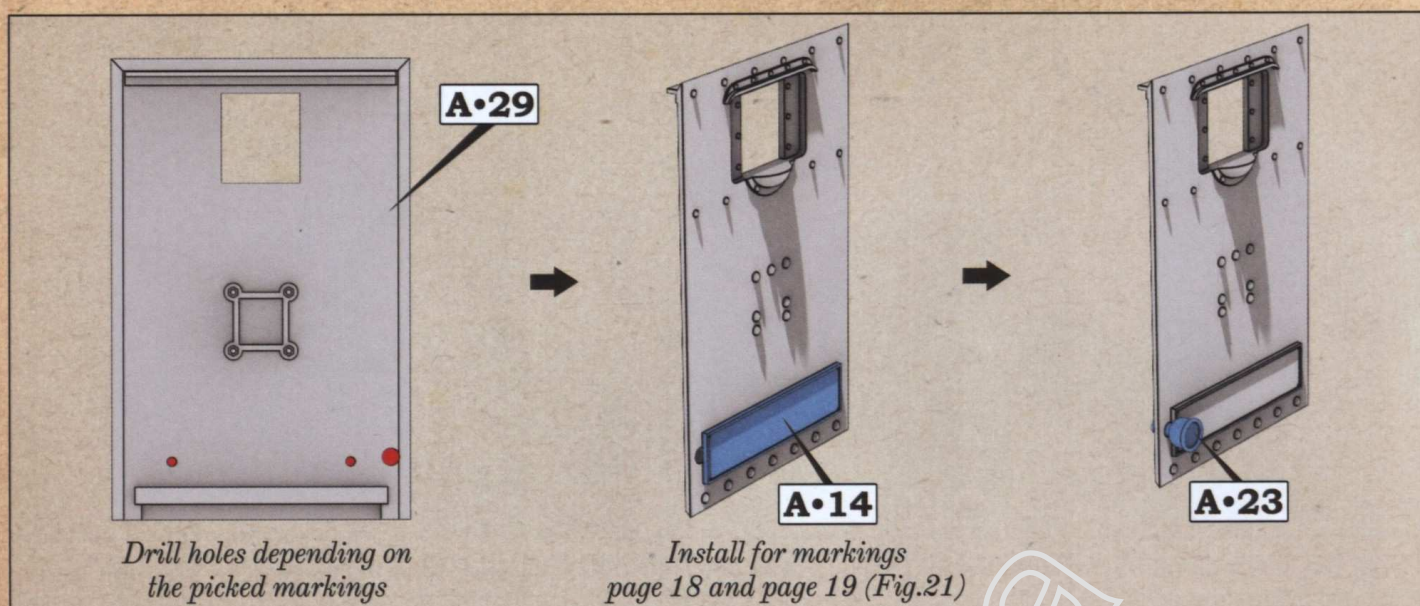

**Step 25.** Assembling of the armoured superstructure rear wall

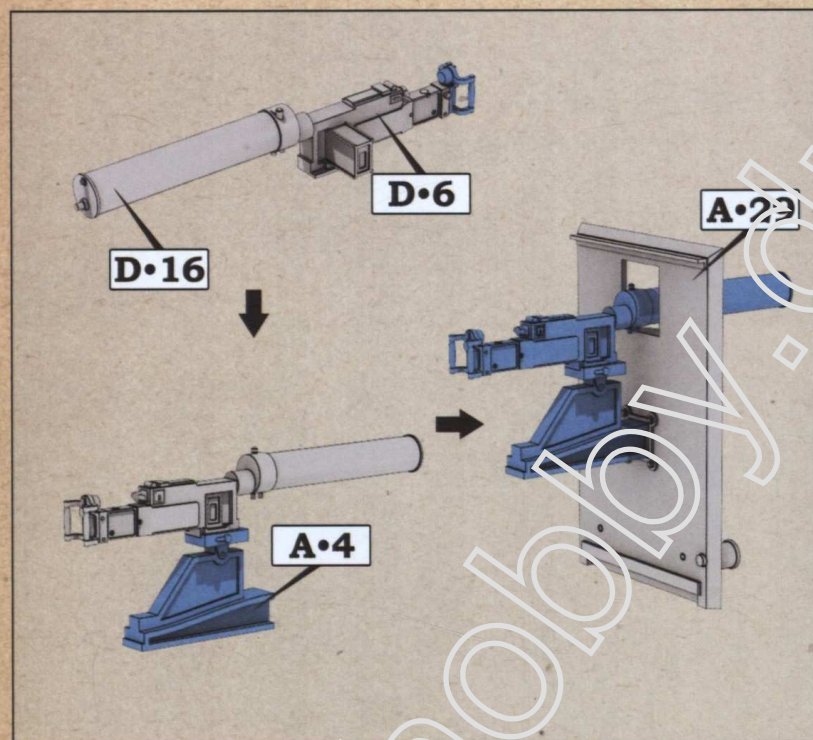

**Step 26.** Installation of the rear MG. Only for markings pages 18,19, 20 (Fig.23) and page 21

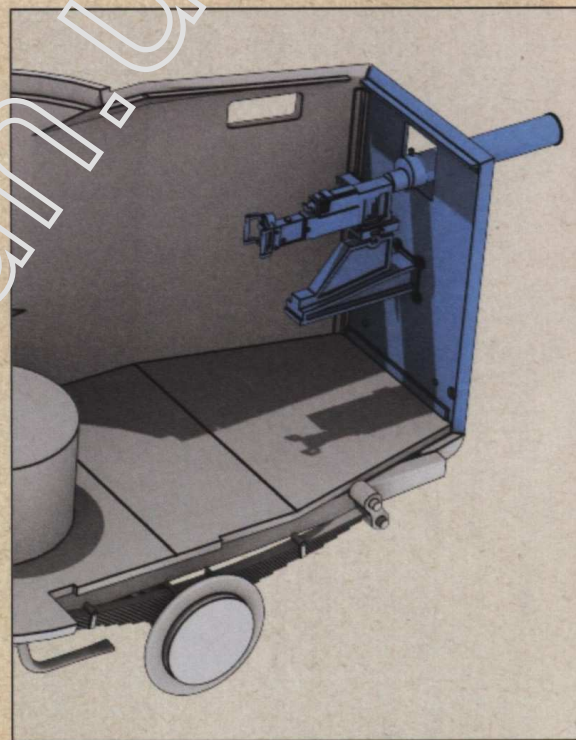

**Step 27.** Installation of the armoured superstructure rear wall

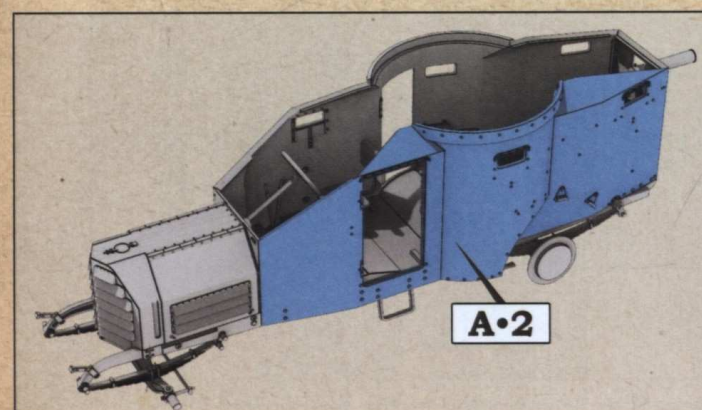

**Step 28.** Installation of the port armoured superstructure wall

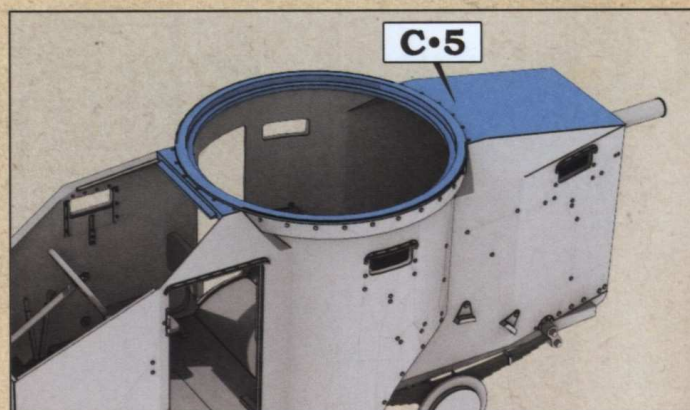

**Step 29.** Installation of the armoured roof

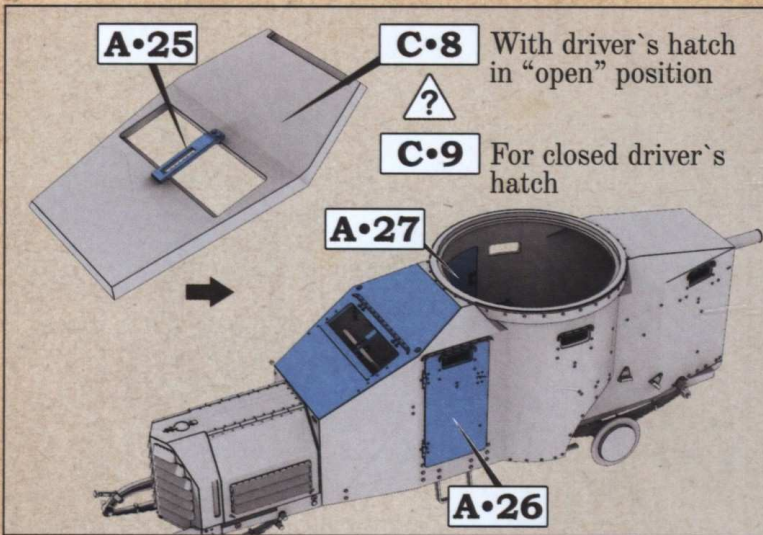

Step 30. Installation of the front armoured plate and doors

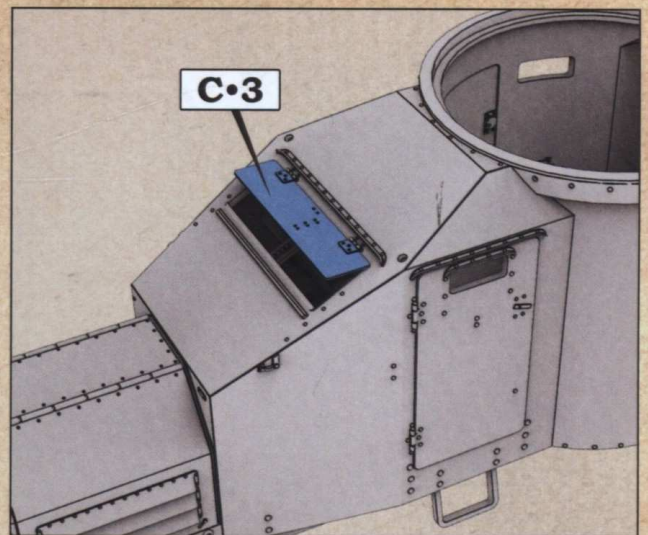

Step 31. Installation of the driver's hatch

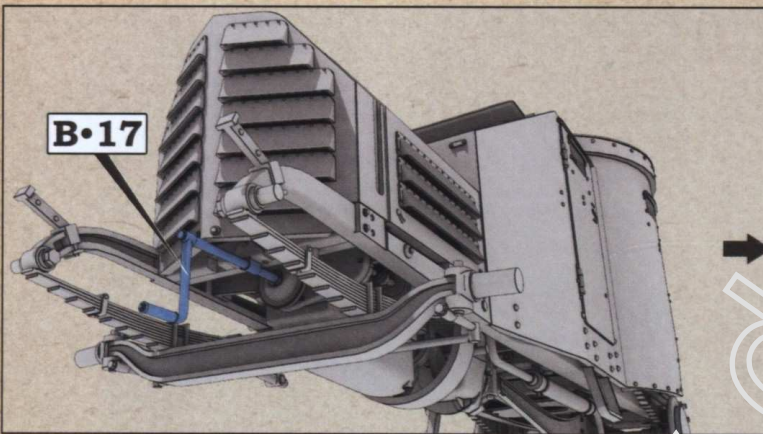

Step 32. Installing the hand crank and the radiator lower armoured plate

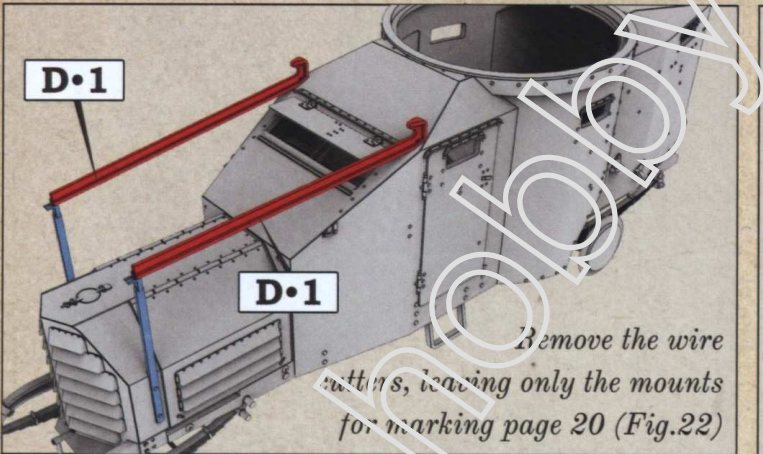
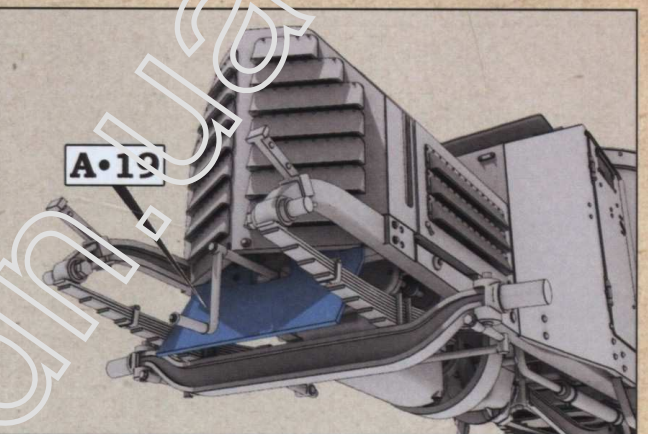

Step 33. Installing the wire cutters

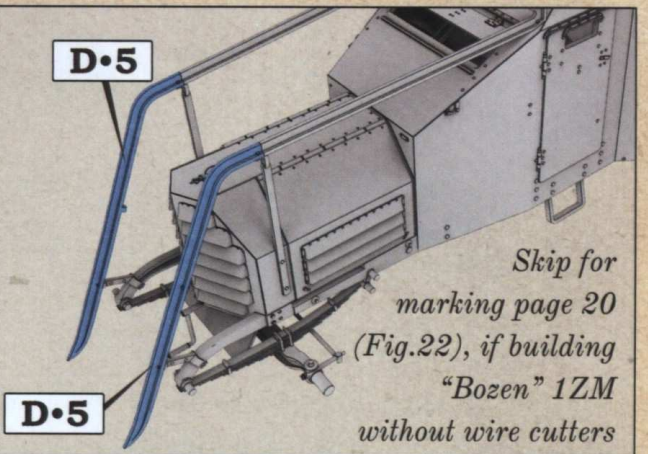

Step 34. Installing the wire cutters

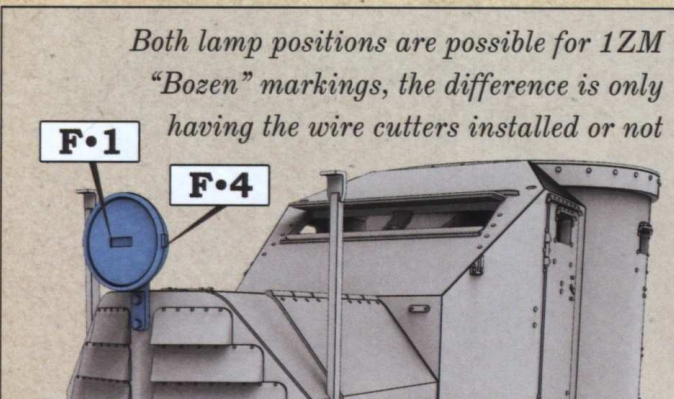

Step 35a. Installation of the headlamp.  
Marking page 20 (Fig.22)

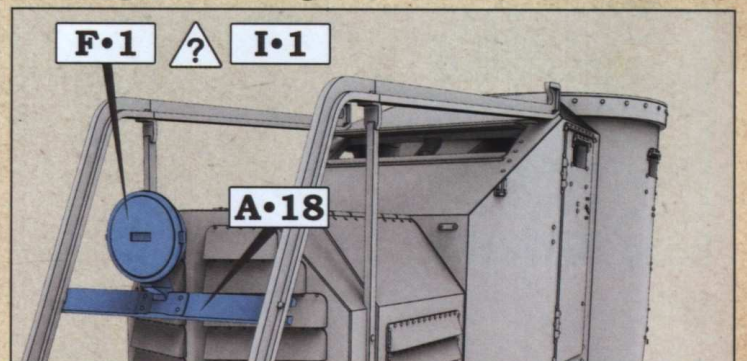

Step 35b. Installation of the headlamp  
Part F.1 for marking page 20 (Fig.22)  
Part I.1 for markings pages 18,19,20 (Fig.23) and 21



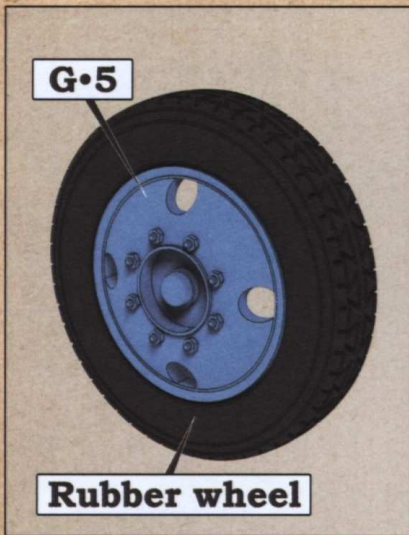

Step 36. Assembling the front wheel. Make two

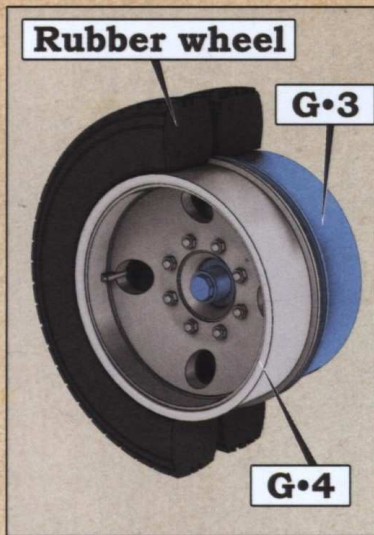

Step 37. Assembling the rear twin-wheel. Make two

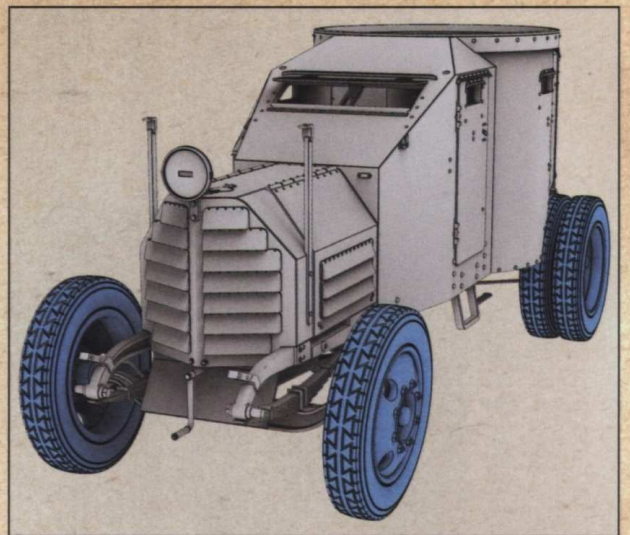

Step 38. Installation of the wheels

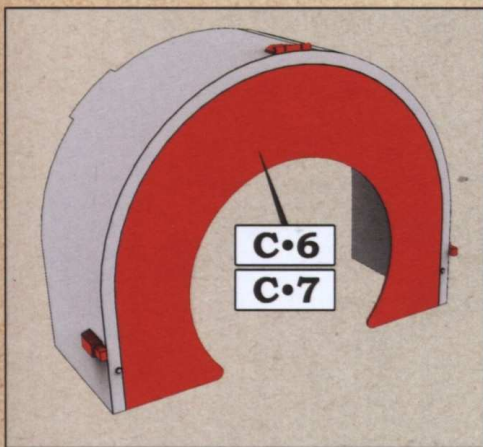

Step 39. Remove fenders panel only for markings page 18

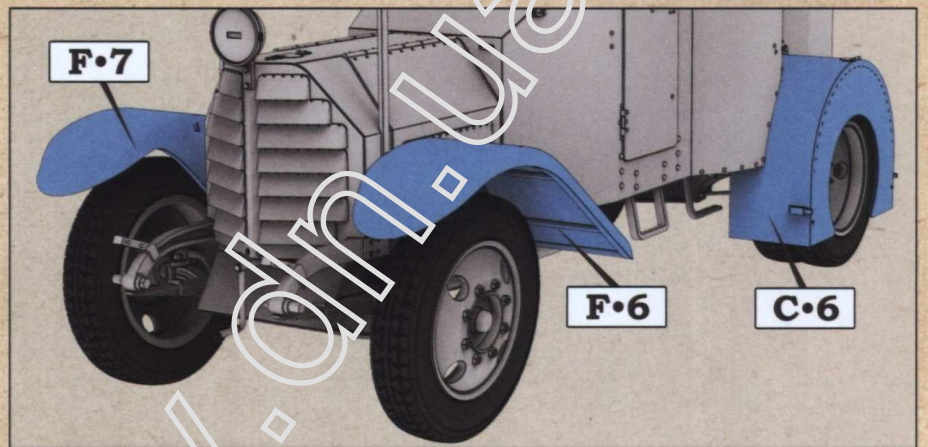

Step 40. Installation of the fenders



Step 41. Installation of the tenders turnbuckles

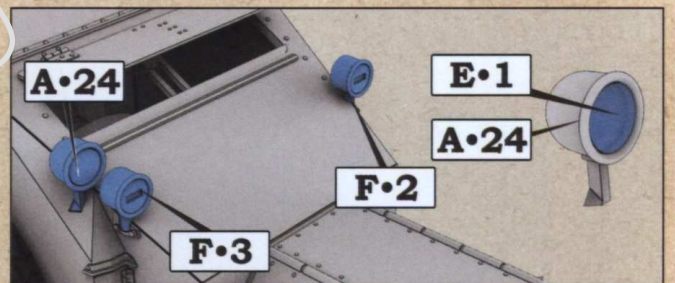

Step 42. Installation of the side lamps A24 for markings pages 18,19,20 (Fig.23) and 21 F3/F2 for marking page 20 (Fig.22)

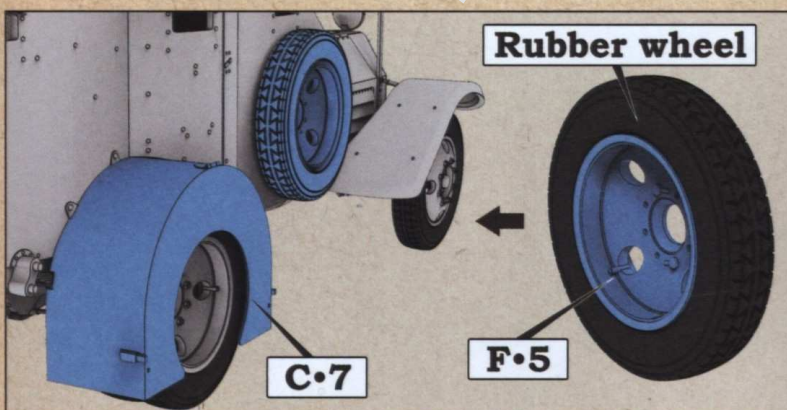

Step 43. Installation of the rear fender and the spare. Do not install spare for marking page 21

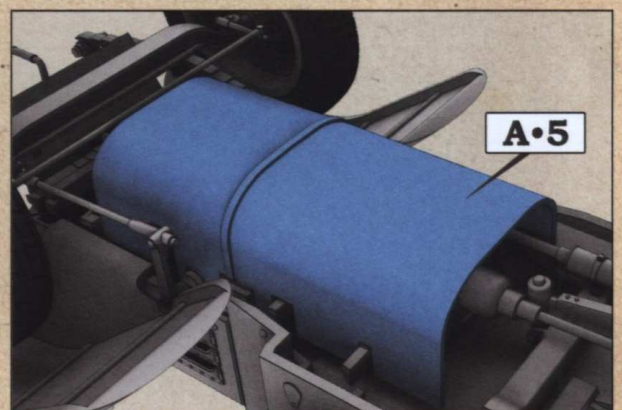

Step 44. Installation of the engine protection

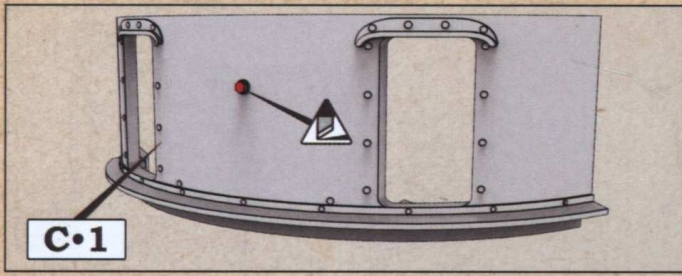

Step 45. Remove the hex head bolt for markings page 19

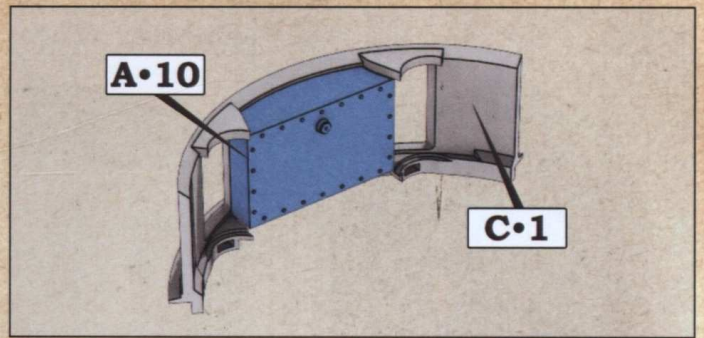

Step 46. Assembling of the turret's front wall

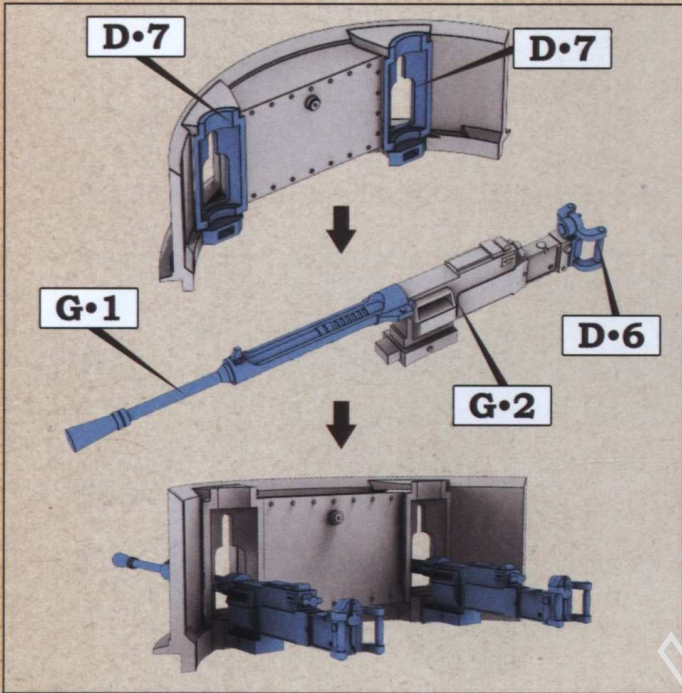

Step 47a. Installation of the turret's Fiat-Revelli 35 MG for markings page 20 (Fig.22)

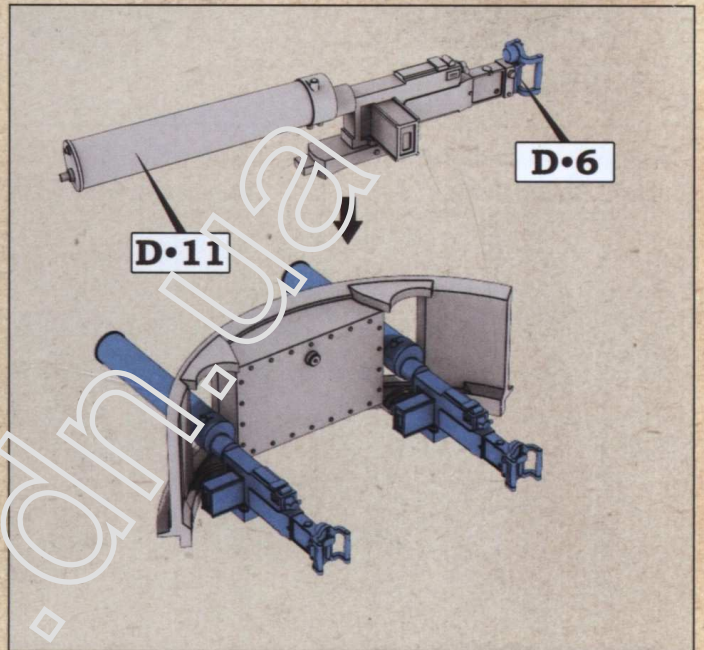

Step 47b. Installation of the turret's Fiat-Revelli 14 MG for markings pages 18,19,20 (Fig.23) and 21

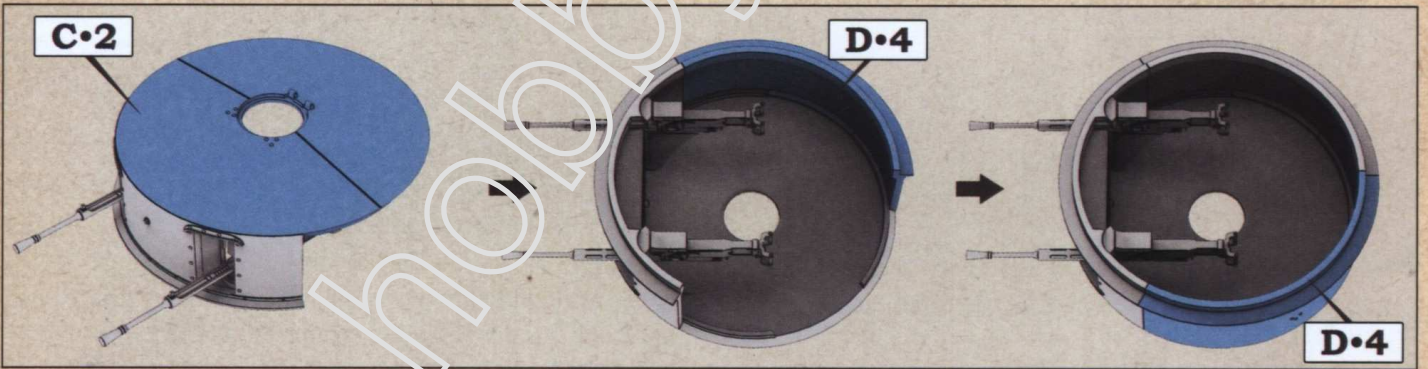

Step 48. Assembling the turret

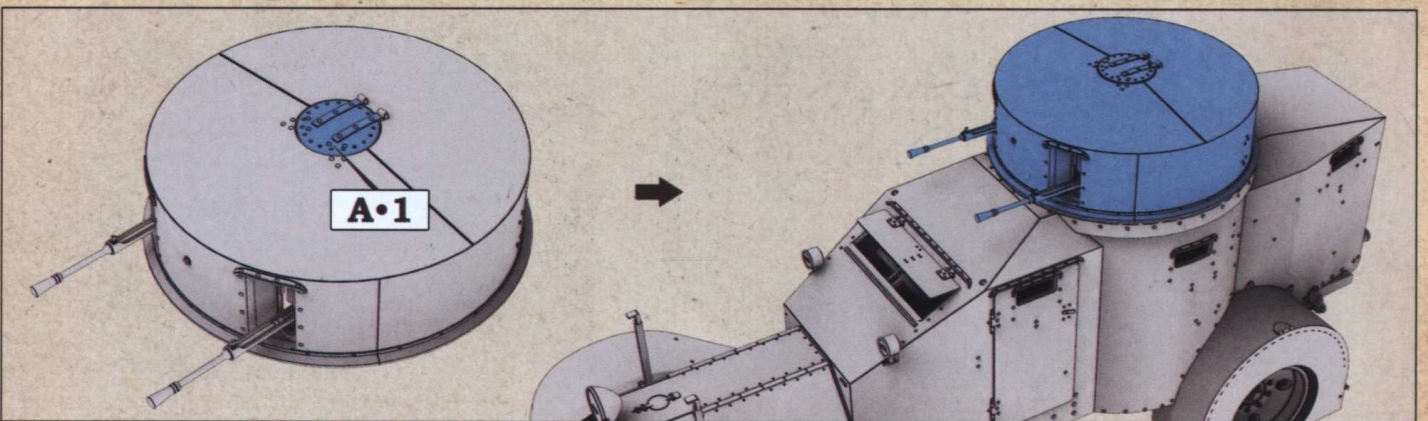

Step 49. Installation of the turret

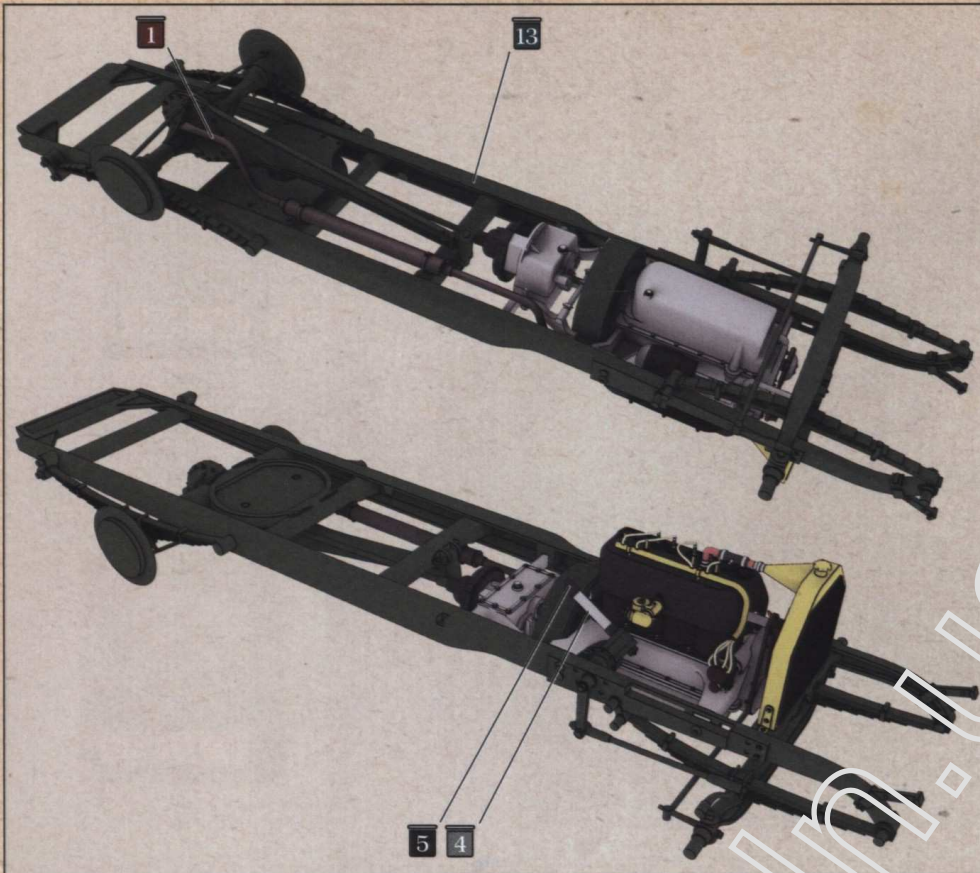

Fig. 12. Colours for the chassis

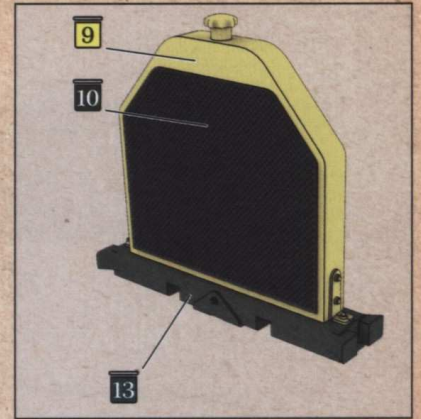

Fig. 13. Radiator colours

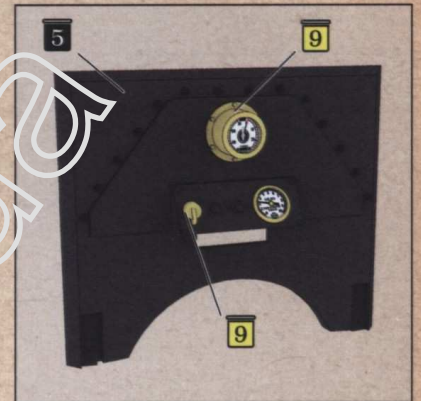

Fig. 14. Dashboard



Fig. 15. Interior colours



Fig. 16. Engine compartment

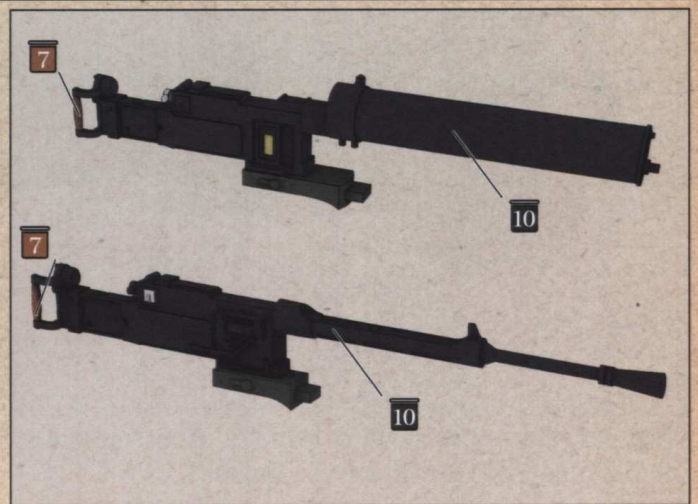

Fig. 17. Machine guns

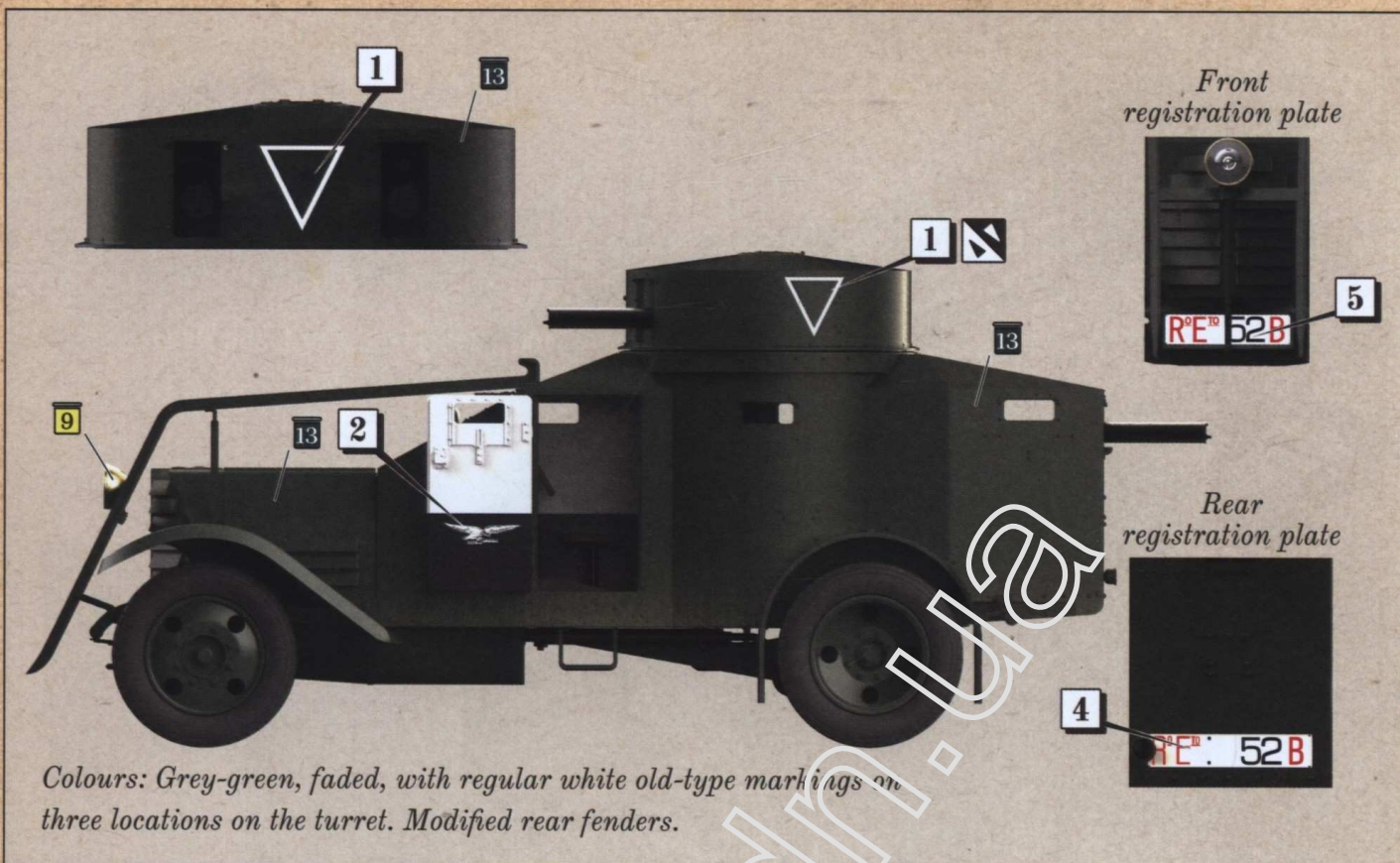

Fig. 18. Composite Battalion, 2nd Platoon HQ, Ethiopia, 1938.

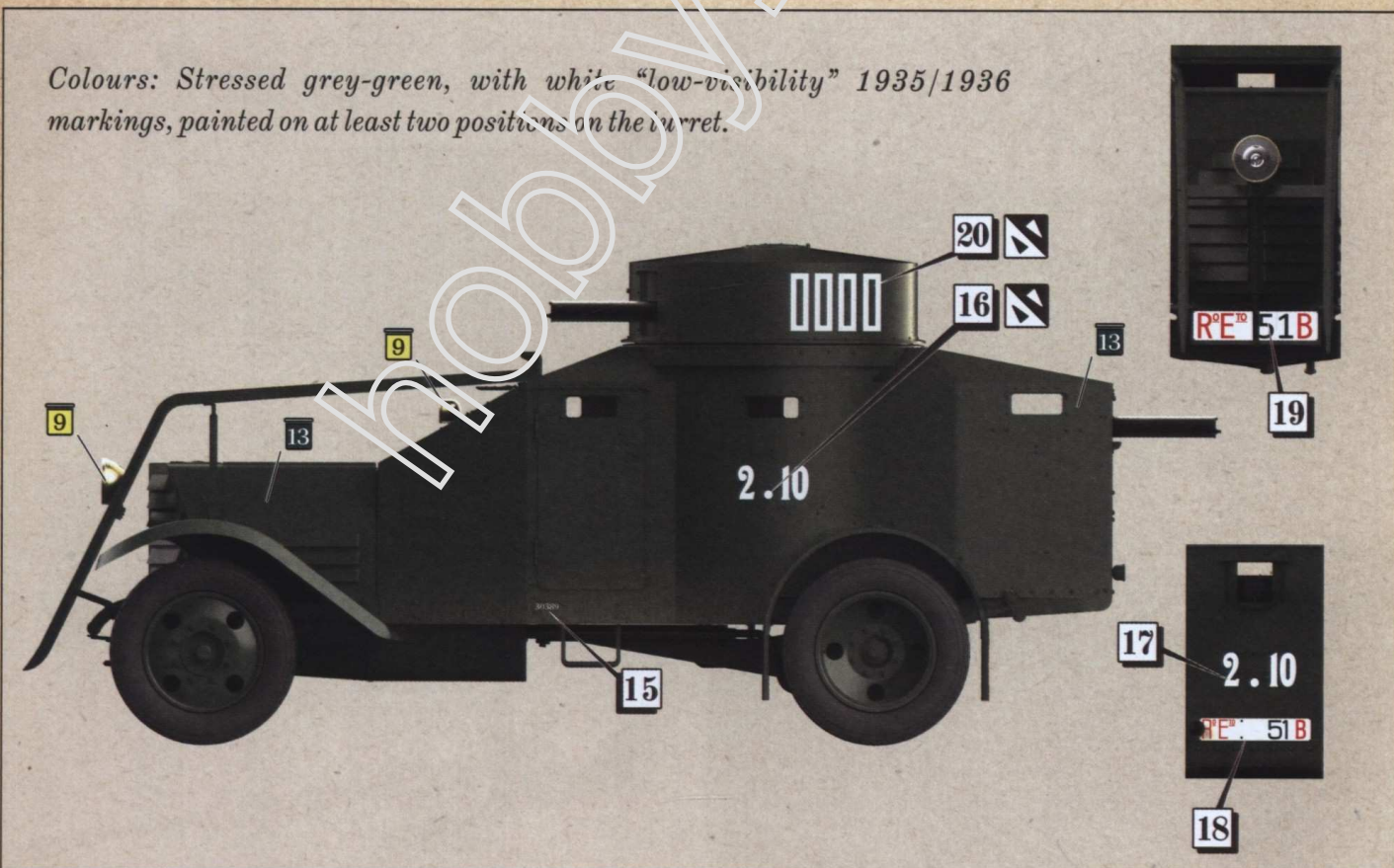

Fig. 19. 2nd Special Squadron "S" (for Somalia), Giuba River, Ethiopia, Summer 1938. This vehicle was commanded by Sgt. Rosario Cinque

Colours: Grey-green (freshly repainted) with new-type markings (white rectangles with a small black "4" on three sides of the turret). On the hull sides is the name of the old unit in white (REGG.to CARRI ARMATI), and on the hull bottom in white are technical stencil for bridges TARA Q. 36 (upper row) and PORTATA Q.8 (bottom row).

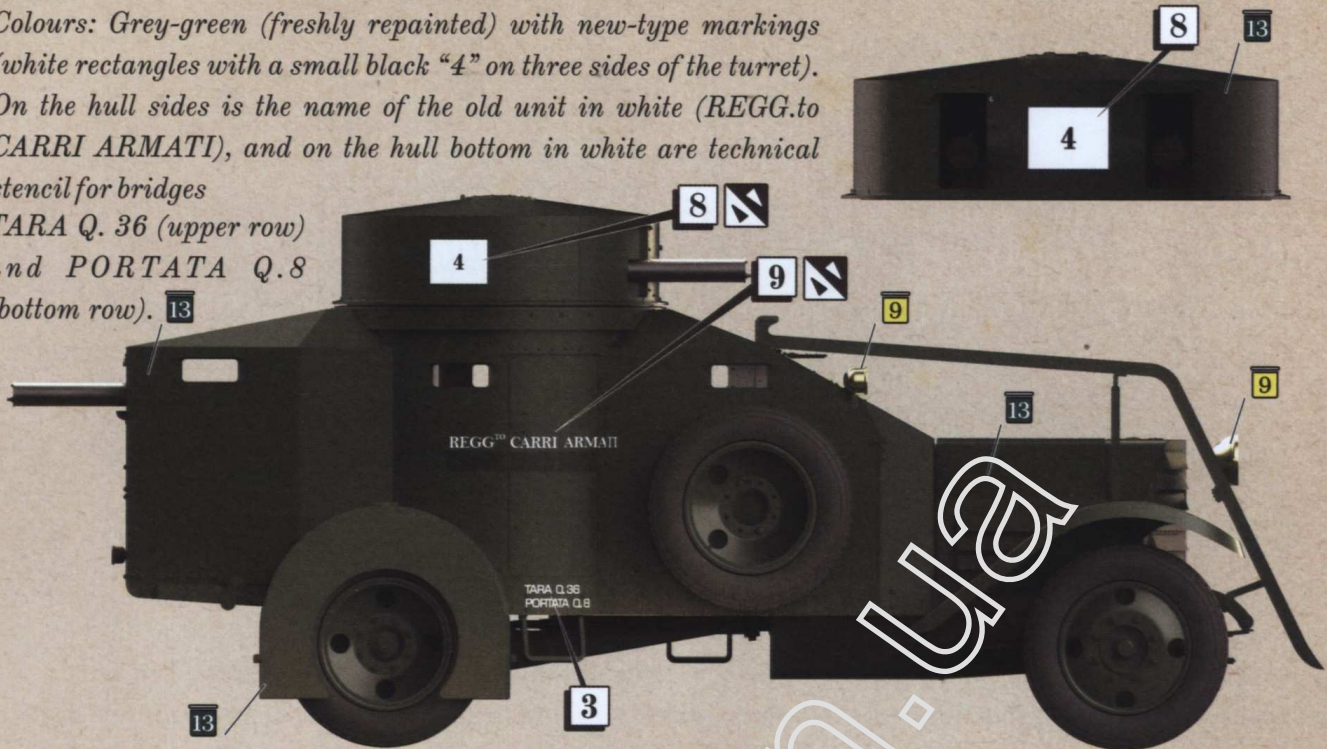

Fig. 20. 312th Mixed Battalion, Psito (Rhodes Island), around 1939

Front registration plate



11 ? 13

Both vehicle registration plates are correct, since both cars were in the same unit, having the same visible white rectangle markings

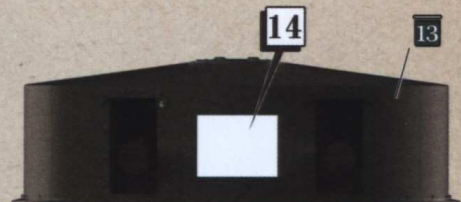

Rear registration plate



10 ? 12

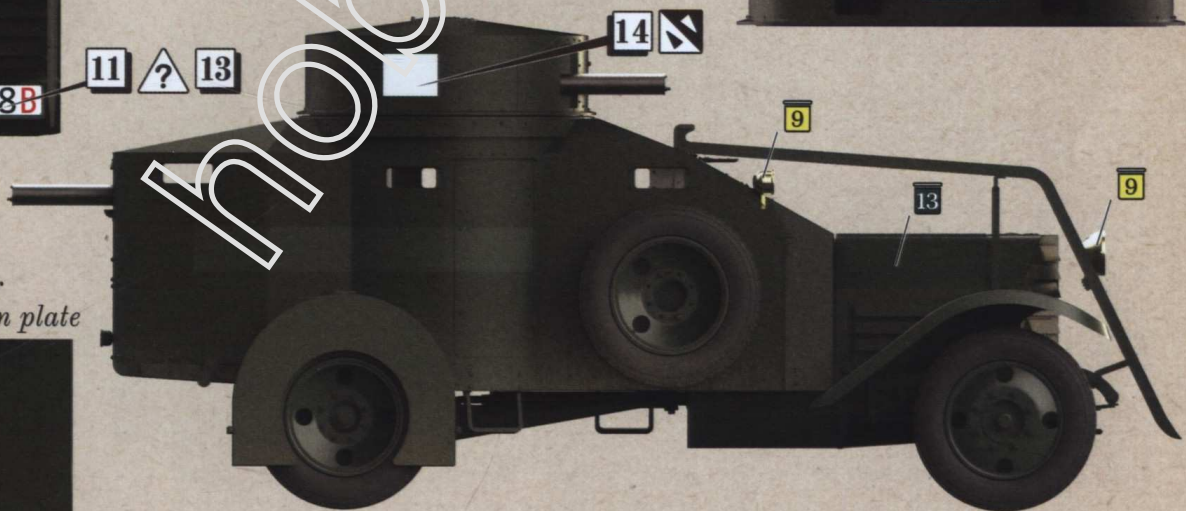

Colours: Ordinary grey-green, with white rectangle markings in three locations on the turret. The original unit identification on the hull side was overpainted in green.

Fig. 21. 312th Mixed Battalion, Samo Island, September 1939



*This vehicle is in one of the main types of "1943" German camouflage patterns with green and brown (maroon) stripes sprayed on a dark yellow background. German crosses may have been applied at some point in this 1ZM's service with the 'Bozen' Police Battalion, but that is not confirmed. A barely visible Italian national flag remained on the turret front wall of at least one of these 1ZMs*

**Fig. 22.** "Bozen" Police Battalion, Northeast Italy, 1944.



**Fig. 23.** This 1ZM belonged to the "Raggruppamento Carrista" (Tank Group). Barcelona, Spain, second half of 1938. During the Spanish Civil War, Italian expeditionary forces didn't carry Italian registration plates or national insignia, as Italy was not officially in the war.

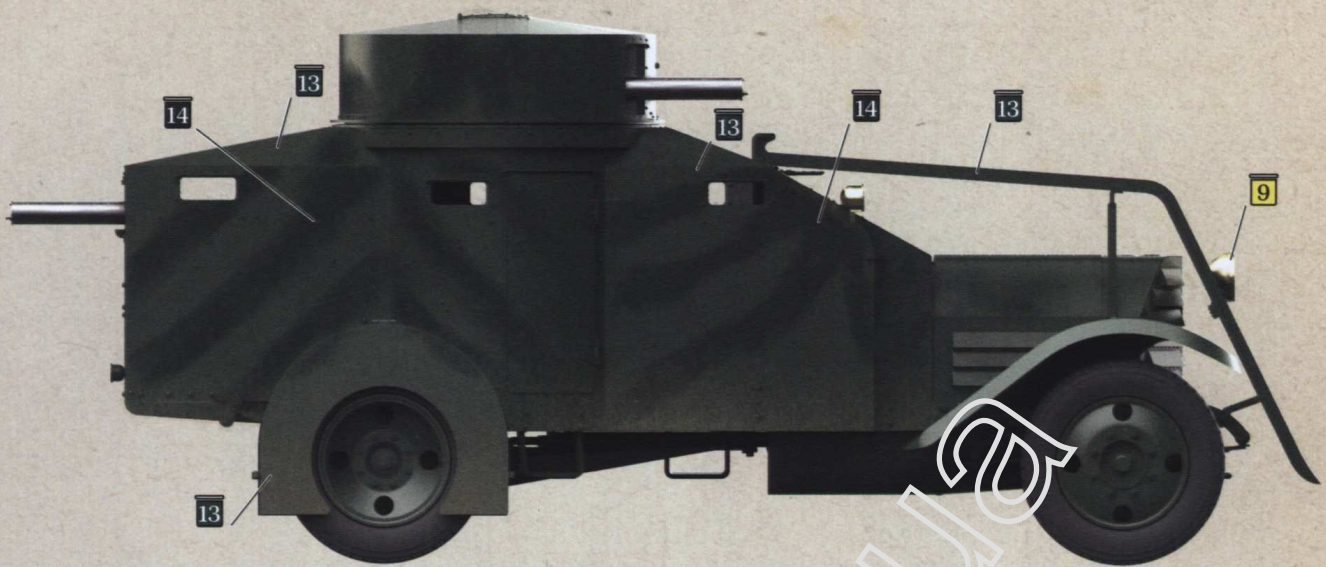

*Regulations for 1ZMs in the older grey-green paint called for the application of other colors. This 1ZM may have kept the grey-green base color with broad stripes of a darker green "Circolare M. 2174 /g, early July, 1943," but that scheme is speculation.*

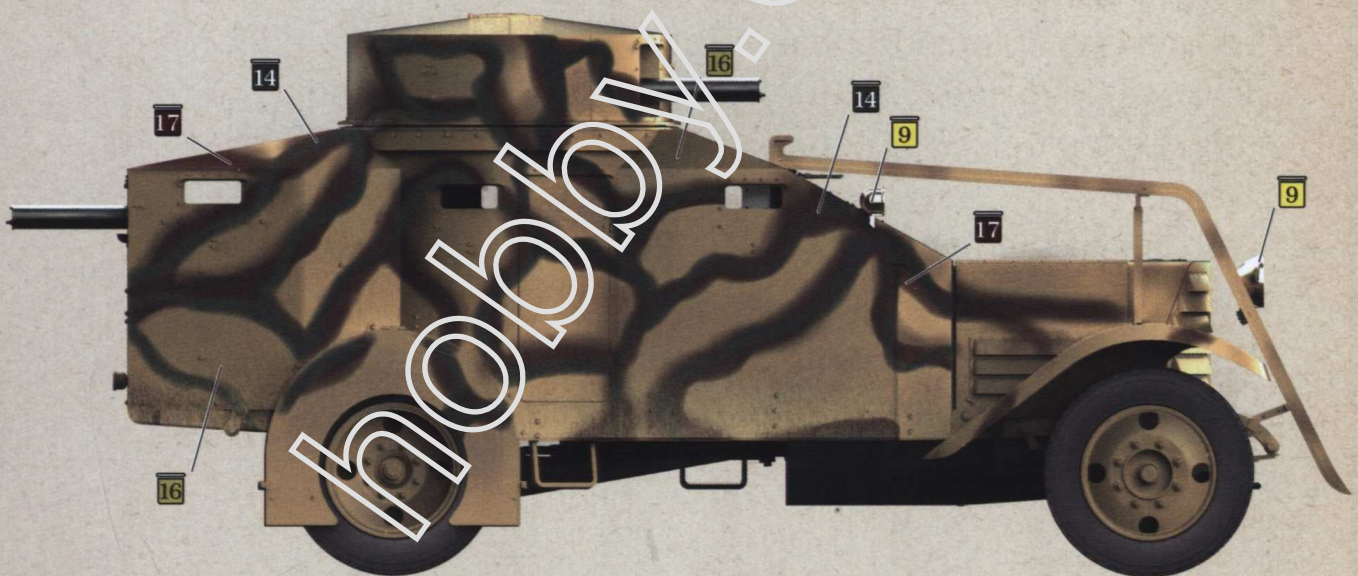

*A second speculation on the colors of this 1ZM is that those armoured cars employed in 1943, after the well-known "Circolare 550/M1941, March 13" established that the equipment in service was to be painted with matte Saharan khaki, and "Circolare 1234/M" established that armoured equipment had to follow the same scheme of Italian armoured trains, which means another base color for this vehicle may have been desert yellow.*

**Fig. 24.** Unknown unit – Balkans 1943