

Der Strassenpanzerwagen Ehrhardt M.1917.

Anleitung für den Zusammenbau,
für die Bemalungen und für die Markierungen.

Mit Genehmigung des Königlich
Preussischen Kriegsministeriums
Herausgegeben

der Masstab 1 zu 35
sku: 35010

==== Riga 1917 ====

Verlag von Modelle des Kupferstaates
Verlagsbuchhandlung für Militärwissenschaften
Cesvainesstrasse 4

Important Notes

- Read the instructions carefully before starting the assembly.
- Use glue intended for plastic models.
- Choking hazard. Keep small parts and plastic bags away from children.
- Always wear protective eyewear when cutting and a protective mask when painting, glueing and sanding.
- Use paints designed and suitable for plastic model kitsets.

Symbols Reference

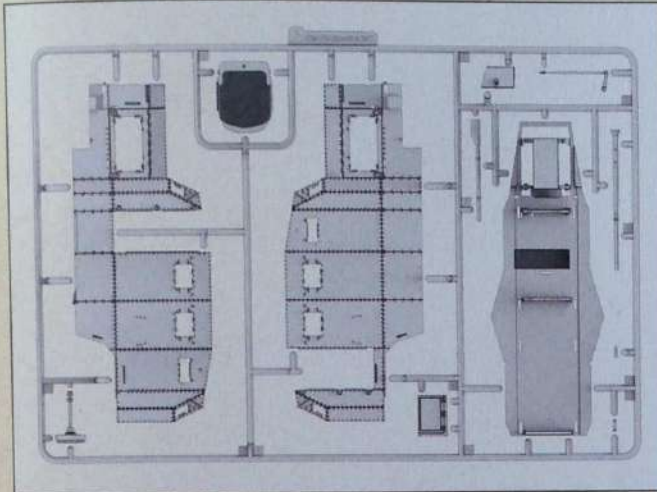
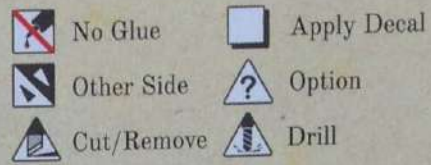

Fig. 1. Runner A

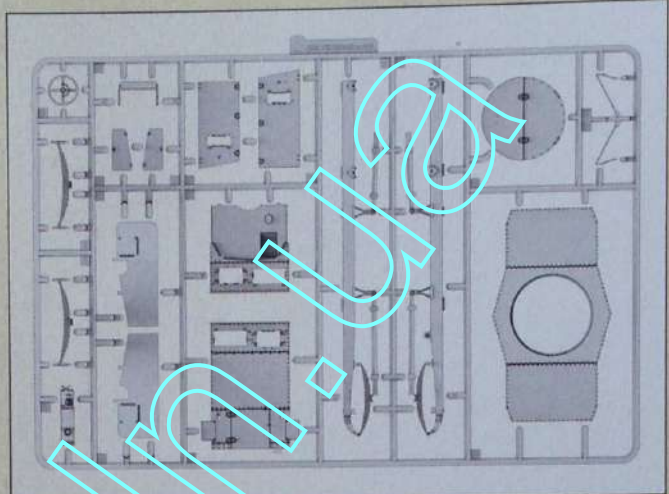

Fig. 2. Runner B

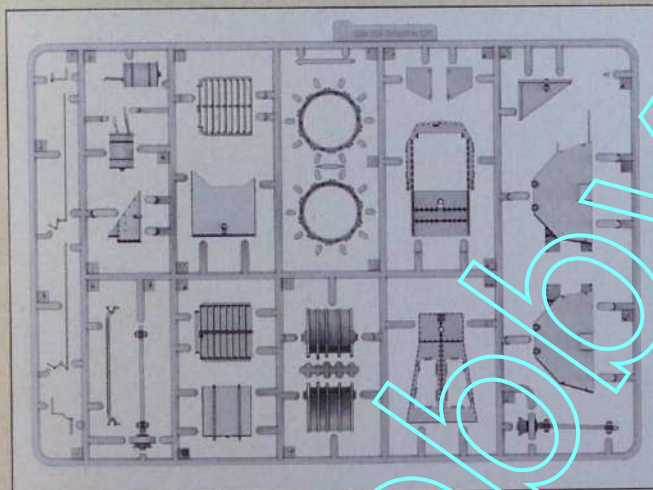

Fig. 3. Runner C

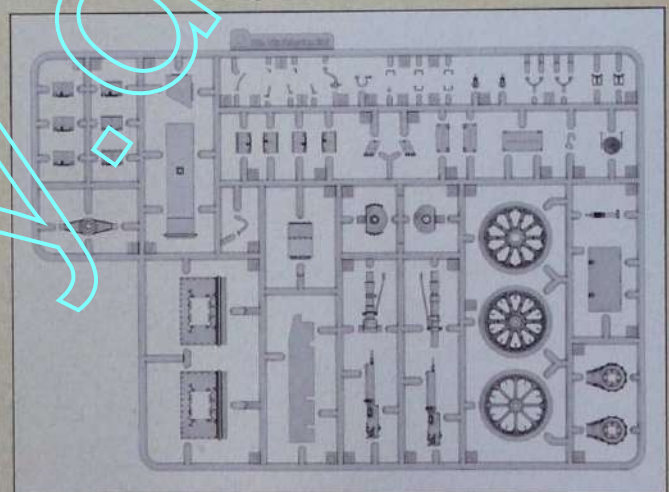

Fig. 4. Runner D, x2

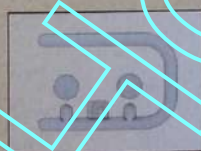

Fig. 5.
Runner E

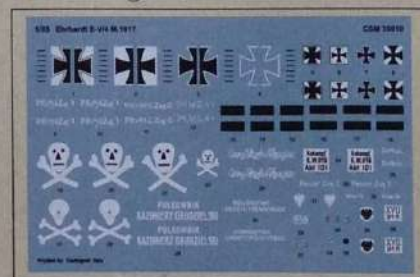
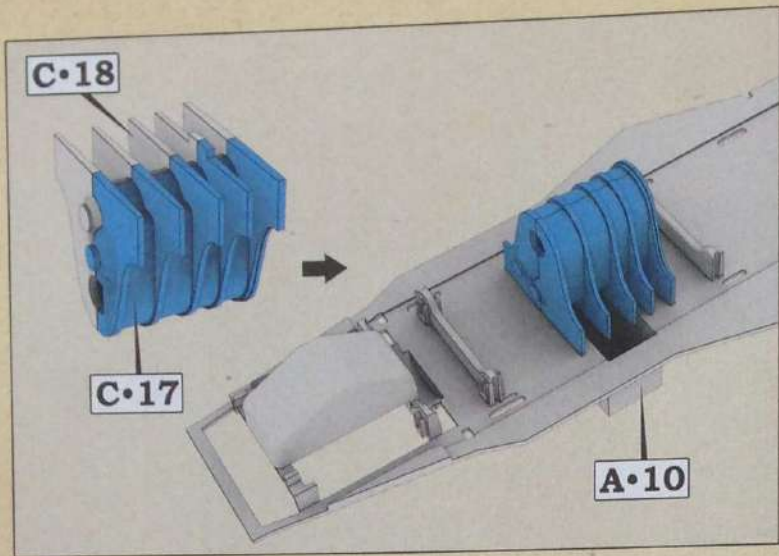

Fig. 6. Decals

Colour numbers

1 German field-grey	4 Gun metal	7 Brown	9 Green
2 Rubber (Grey)	5 Grey	8 Ochre	10 Black
3 Chrome	6 Polish green		



Step 1. Gearbox assembly and installation

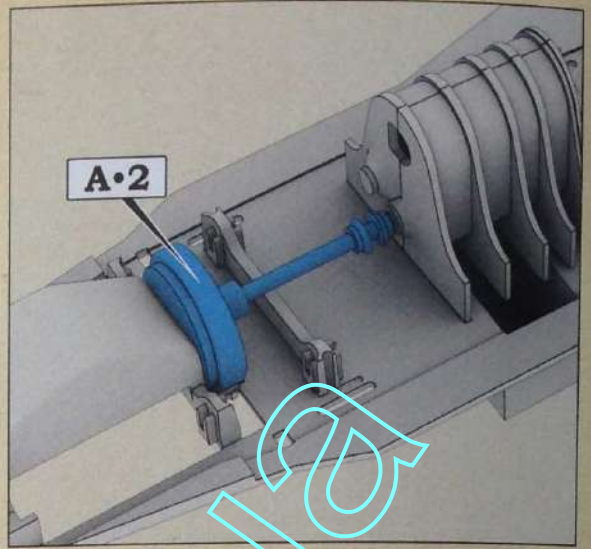

Step 2. Installation of the flywheel

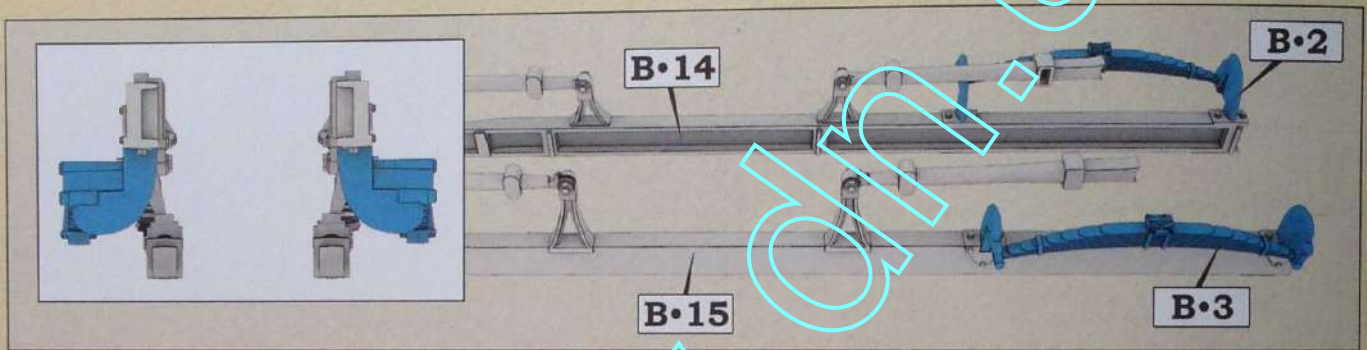

Step 3. Installation of the rear leaf springs

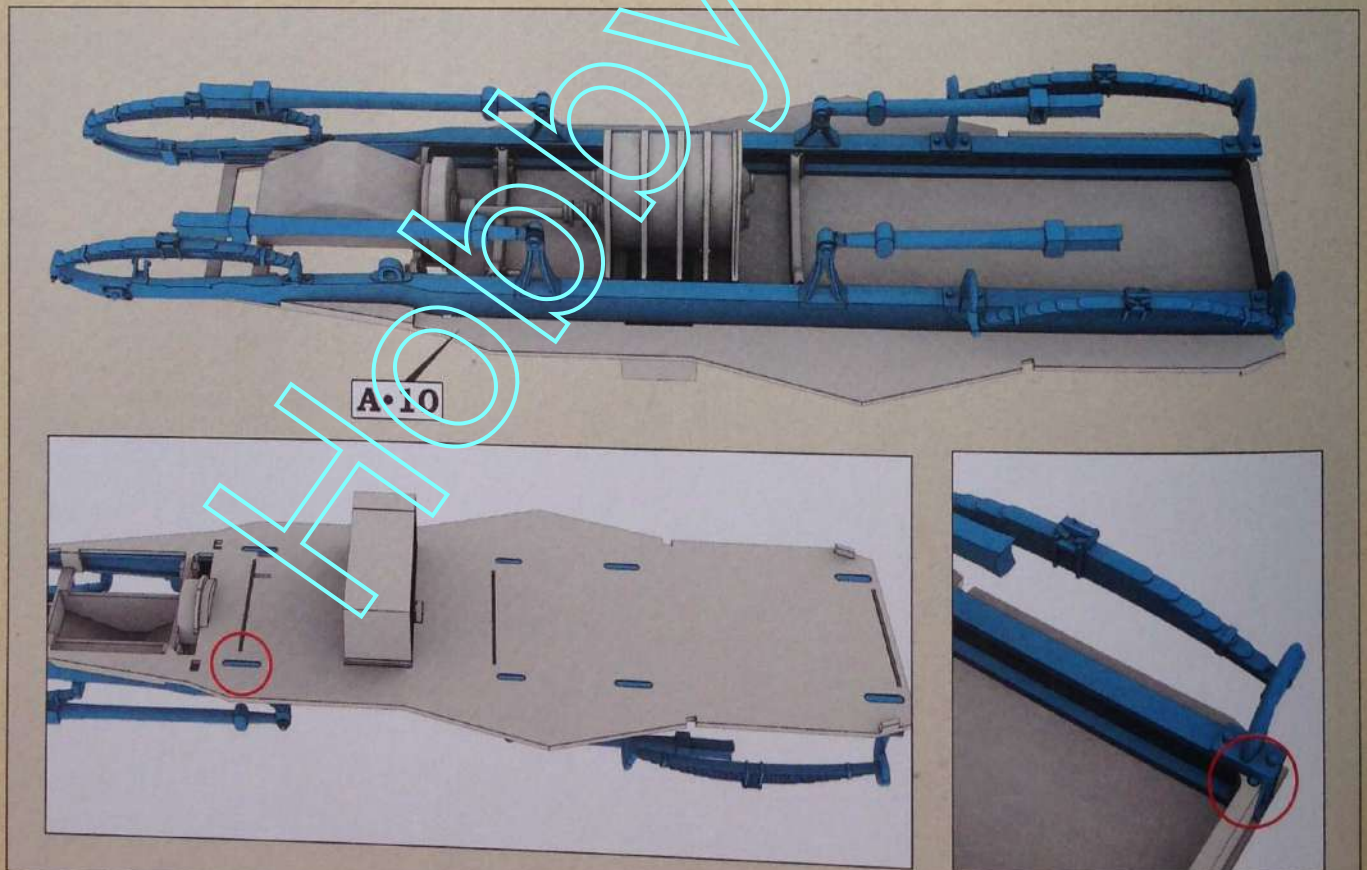

Step 4. Installing both side rails

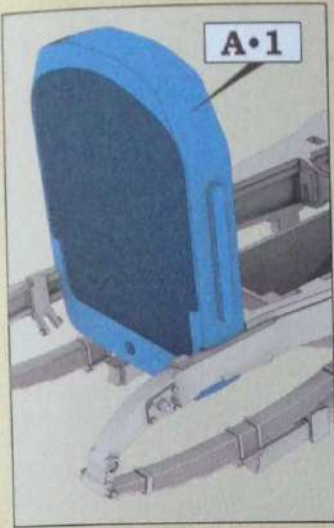

Step 5. Installing the radiator

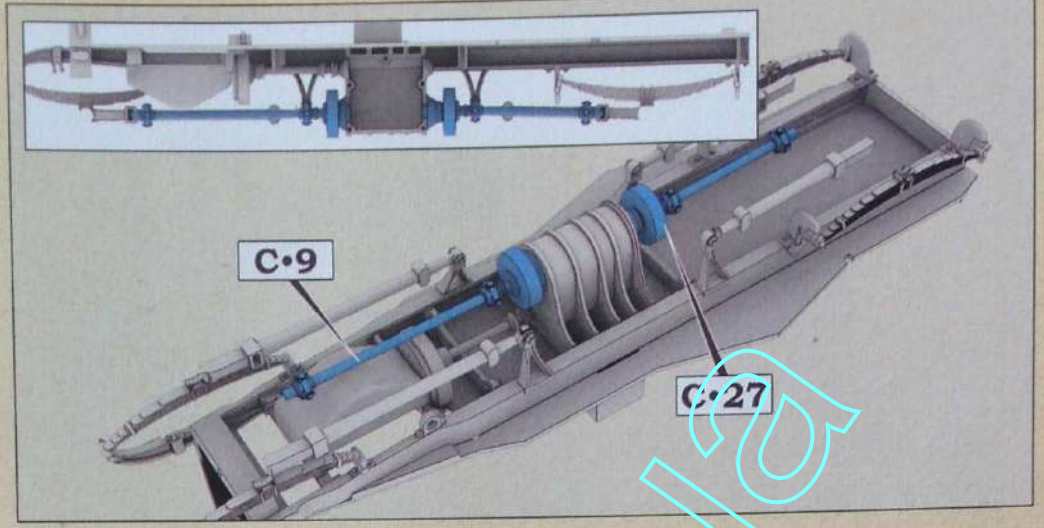

Step 6. Installing both drive shafts

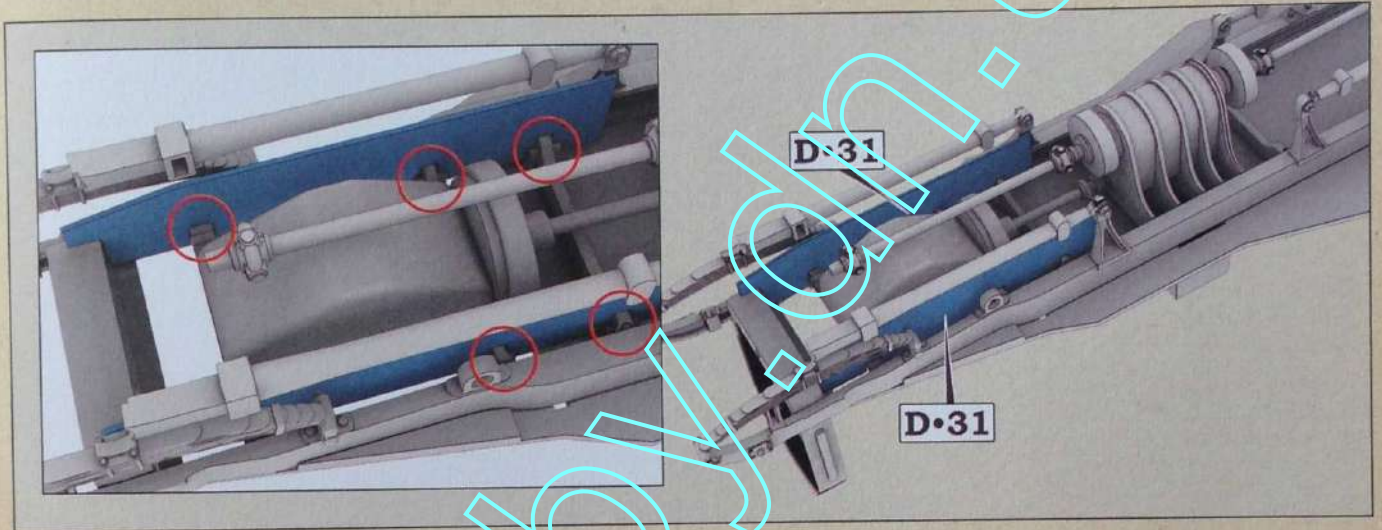

Step 7. Installing the engine protection

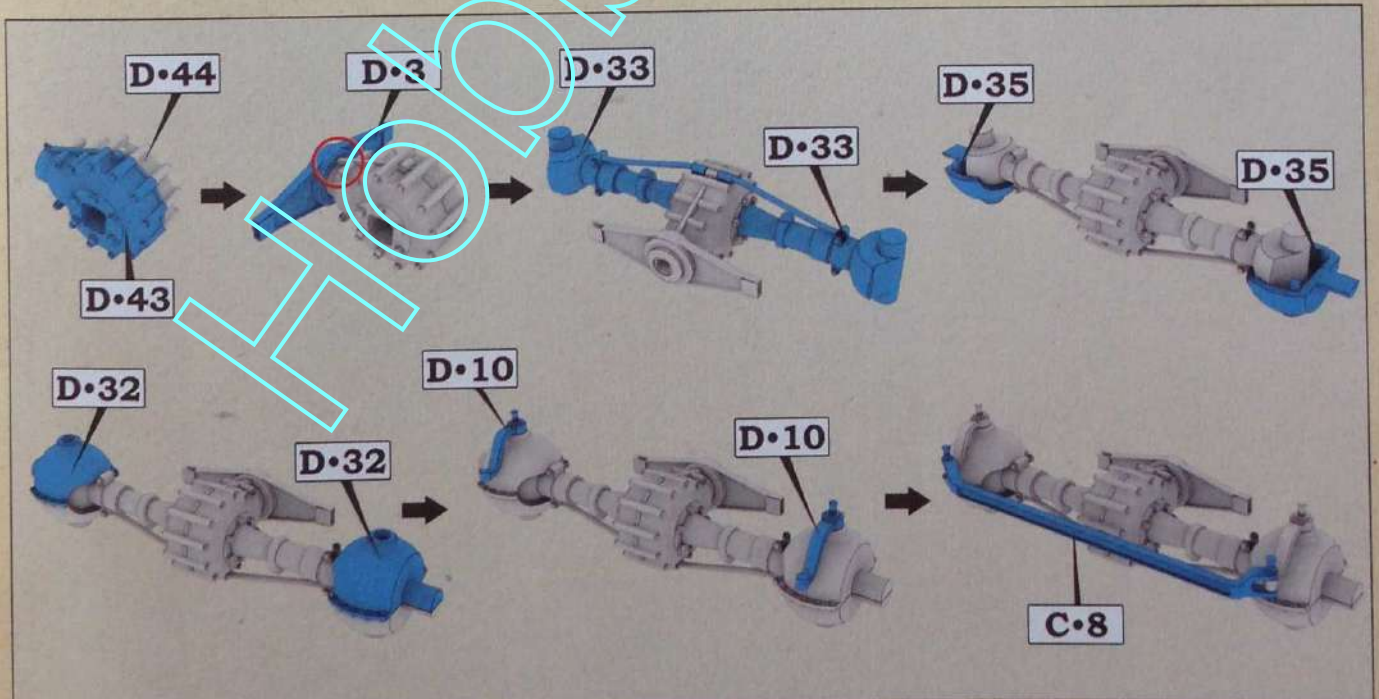

Step 8. Assembling the front axle

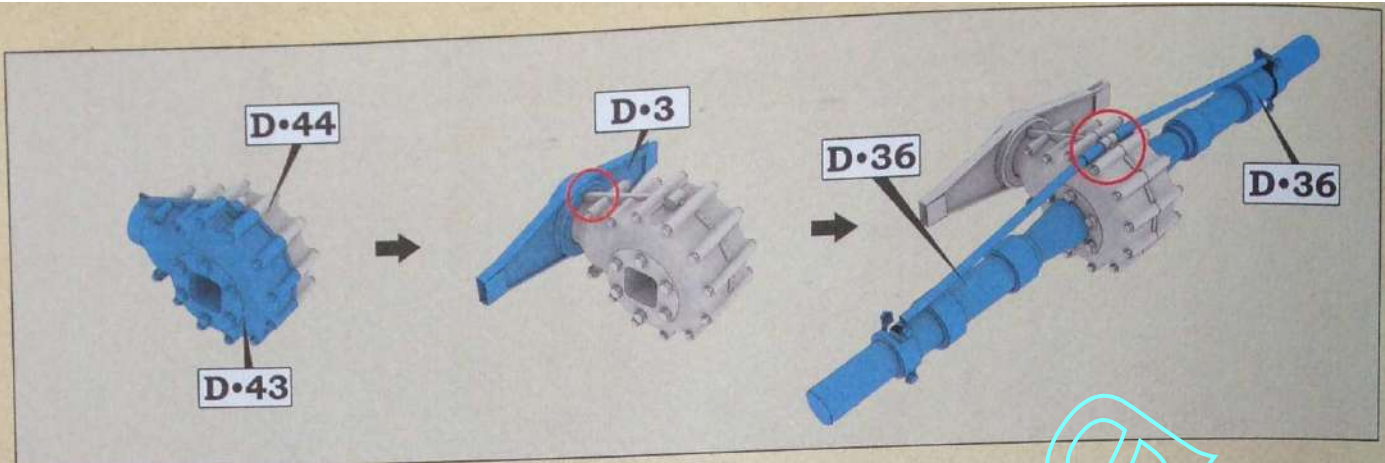

Step 9. Assembling the rear axle

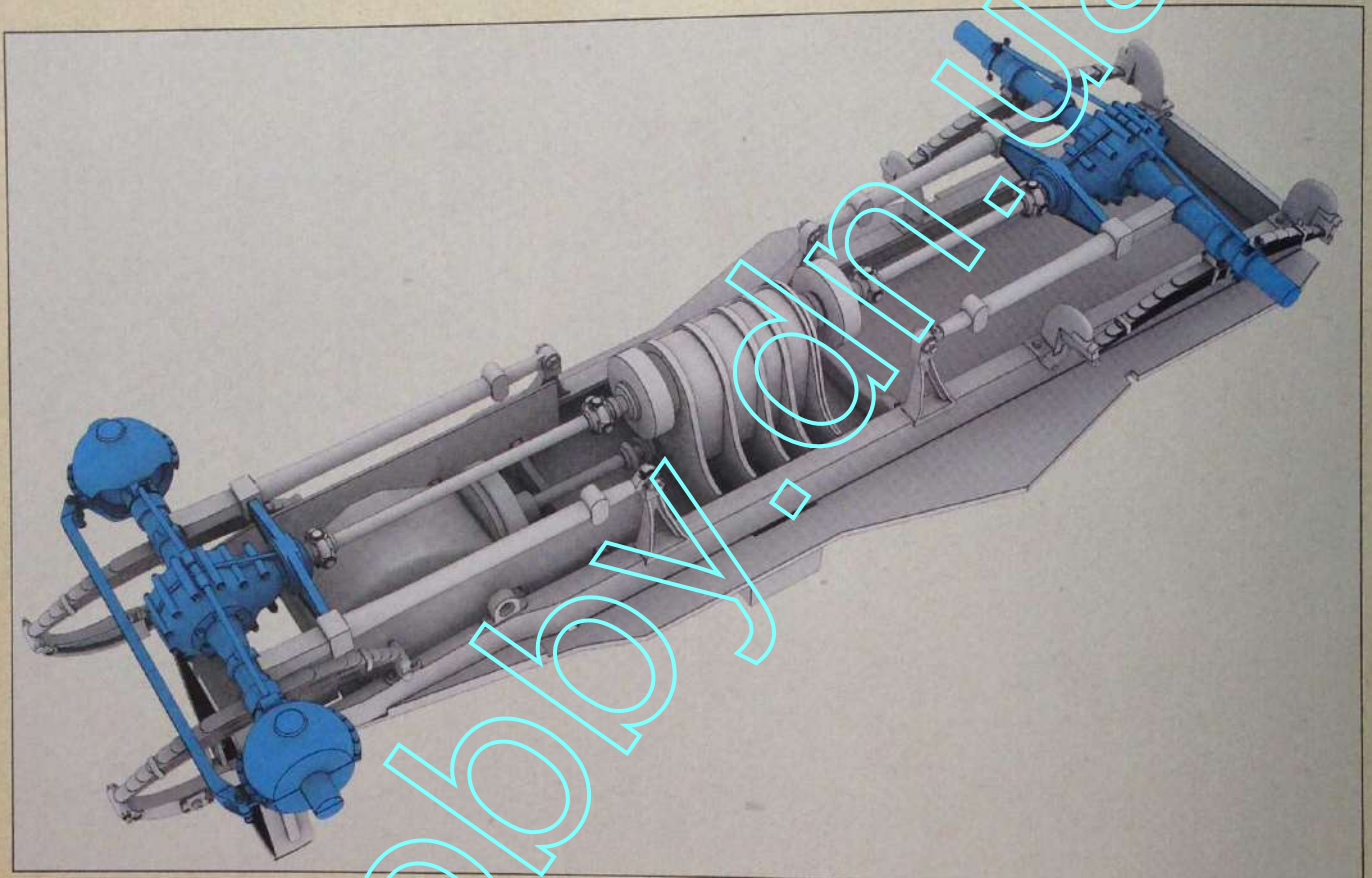

Step 10. Installation of the front and rear axles

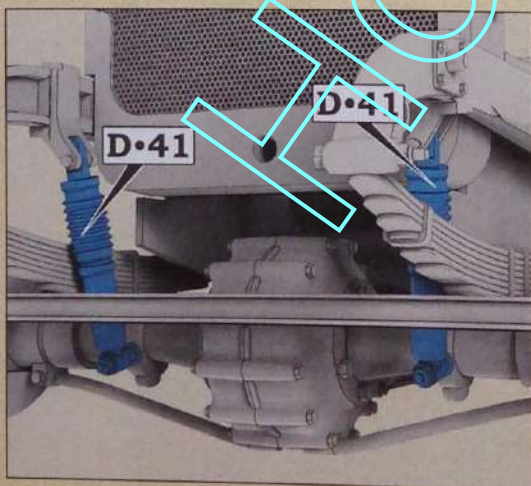

Step 11. Installing the telescopic shock absorbers

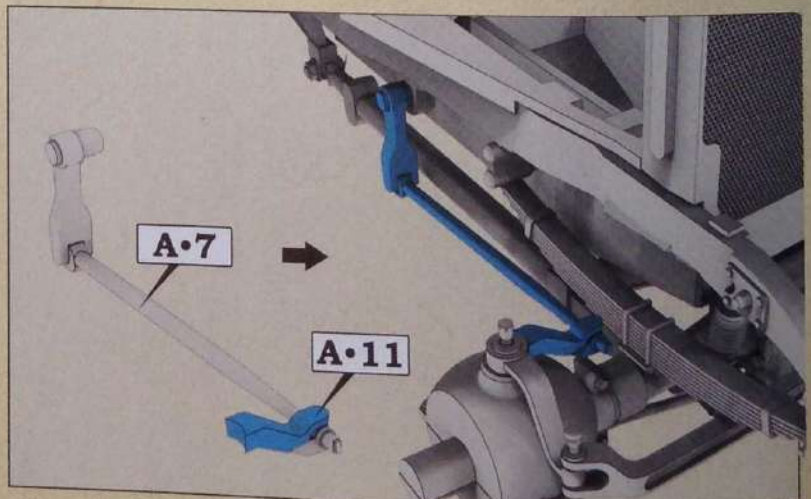

Step 12. Installation of the steering arm

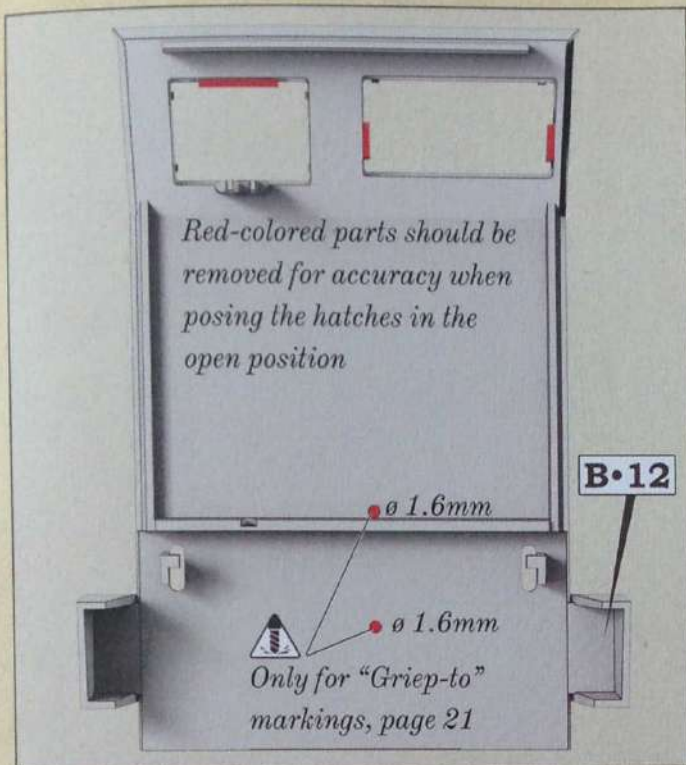

Step 13. Additional actions for B12

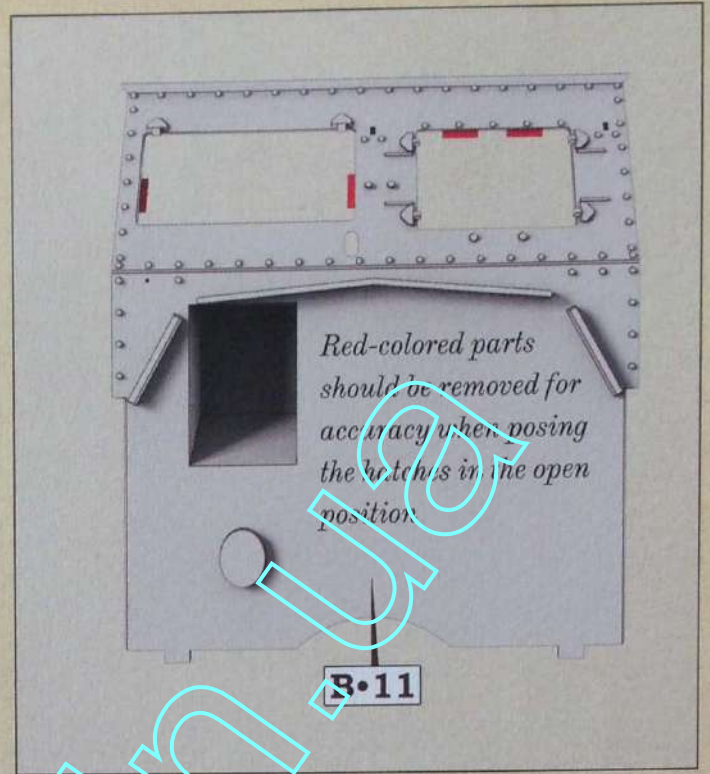

Step 14. Additional actions for B11

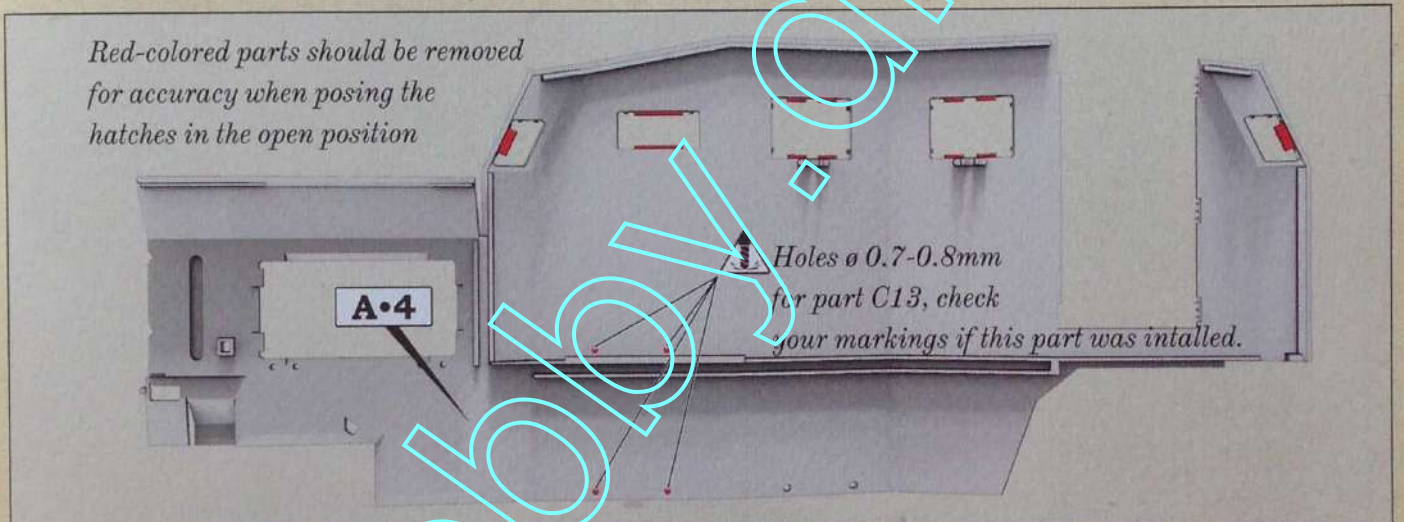

Step 15. Additional actions for A4, at this stage it is easier to install all the closed hatches as per step 38

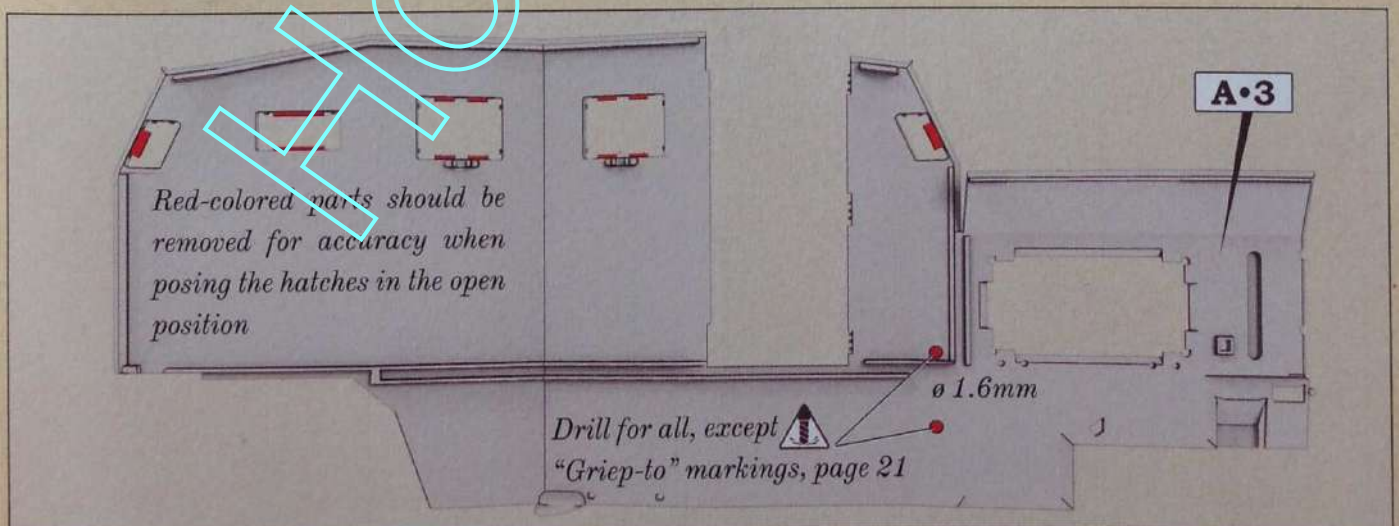

Step 16. Additional actions for A3, at this stage it is easier to install all the closed hatches as per step 37

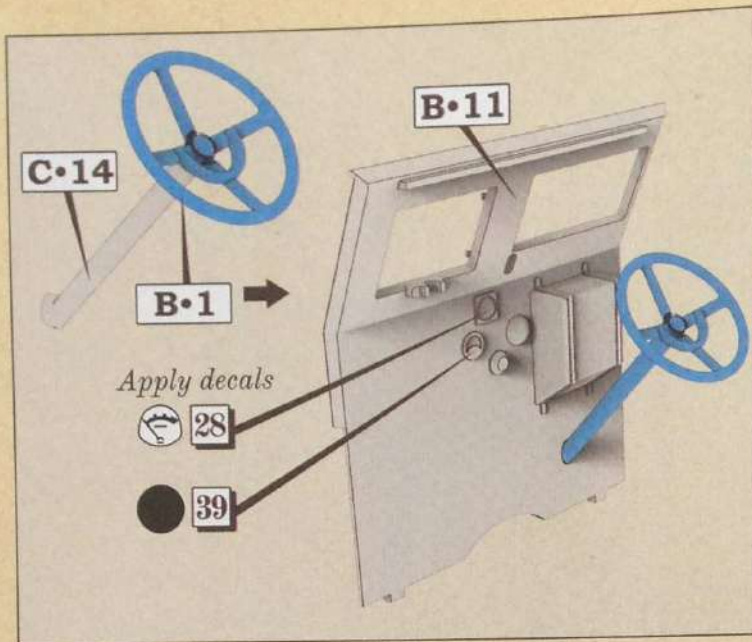

Step 17. Assembling and installation of the steering wheel

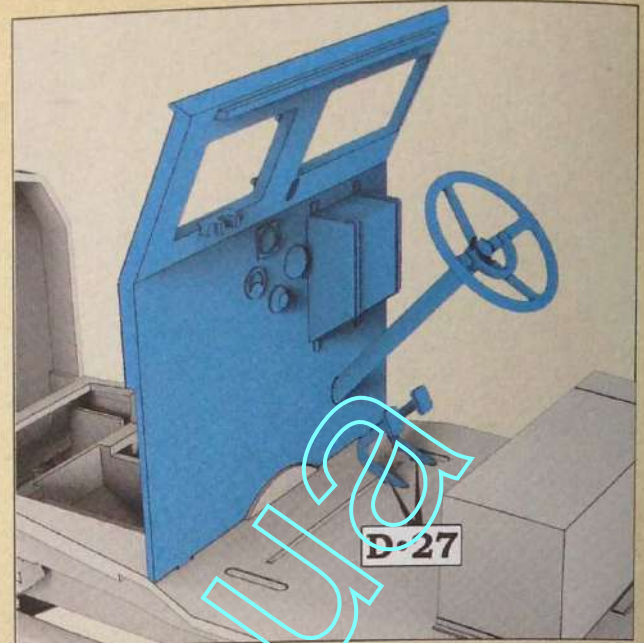

Step 18. Installing the front armoured wall and driver's pedals

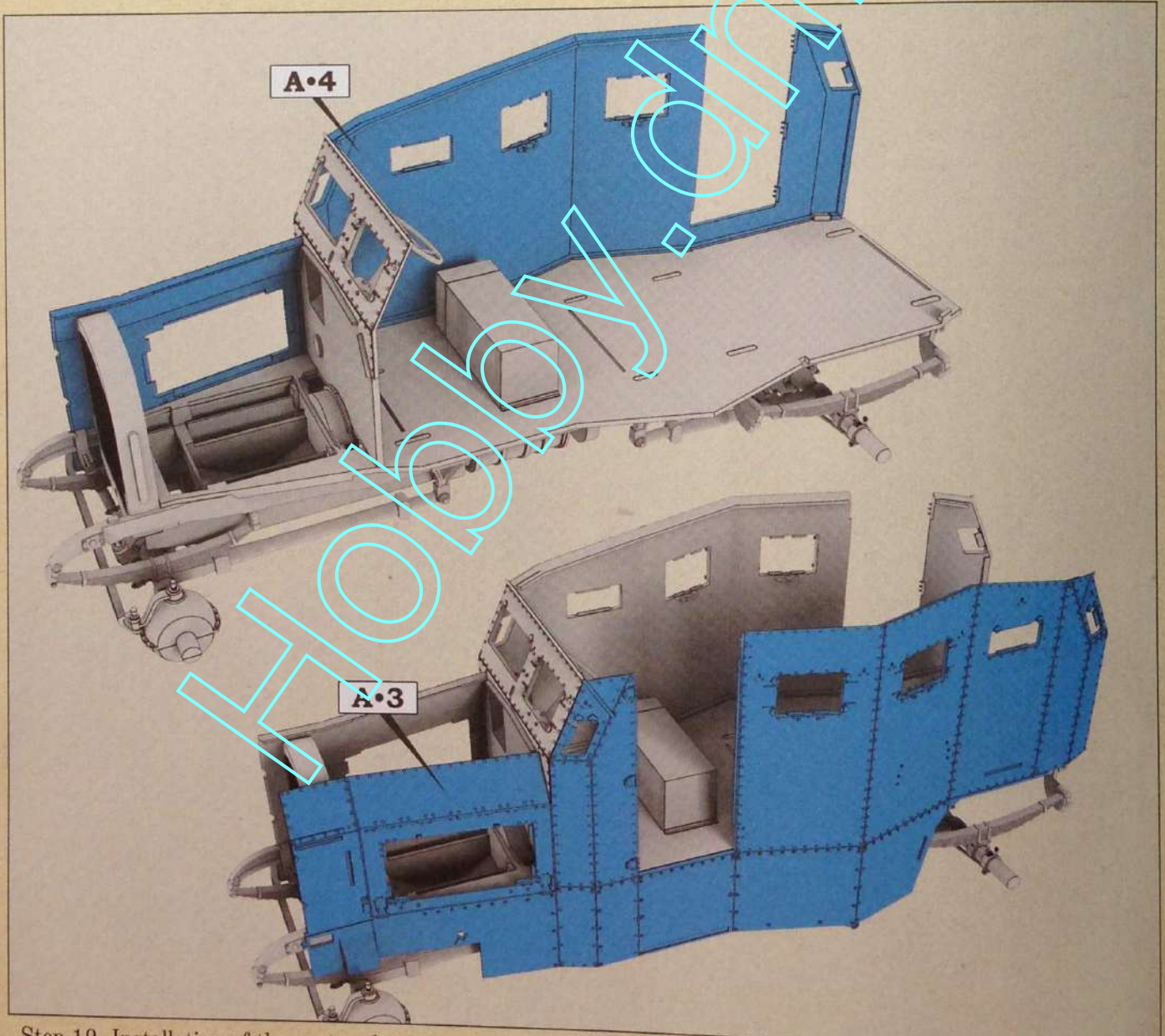

Step 19. Installation of the port and starboard armoured superstructure walls

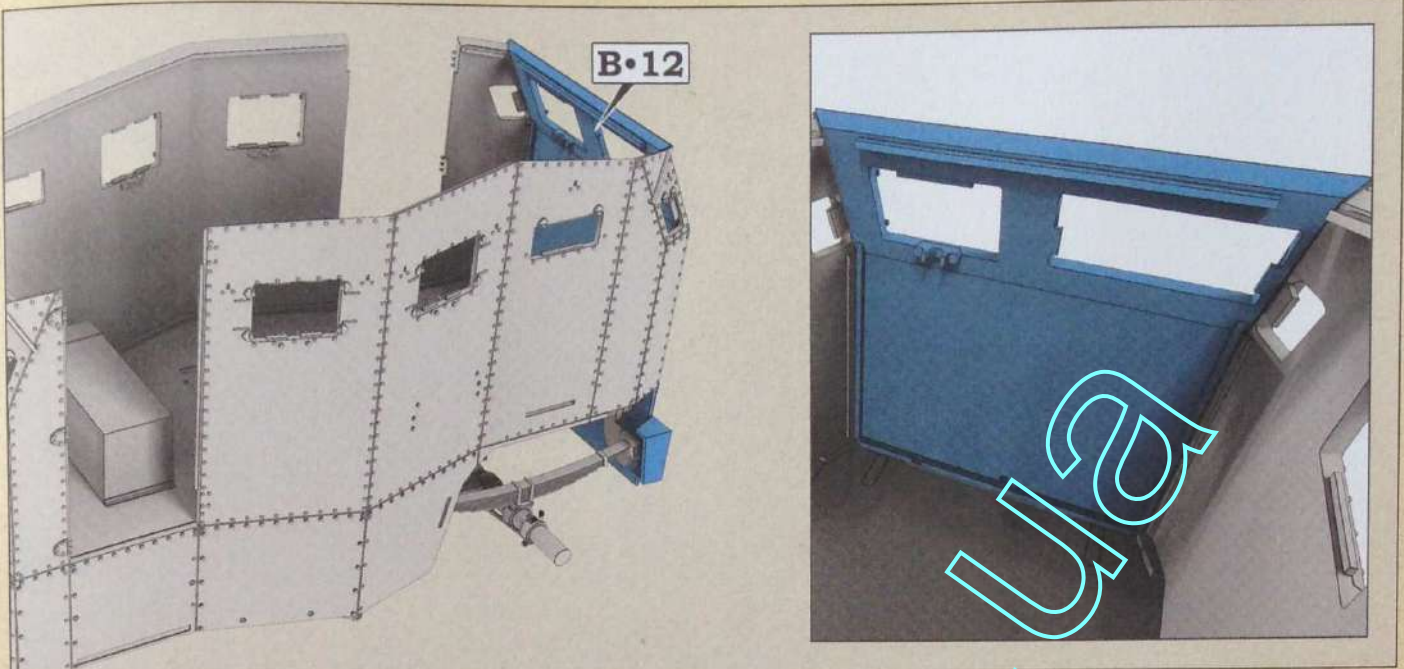

Step 20. Installation of the rear armour

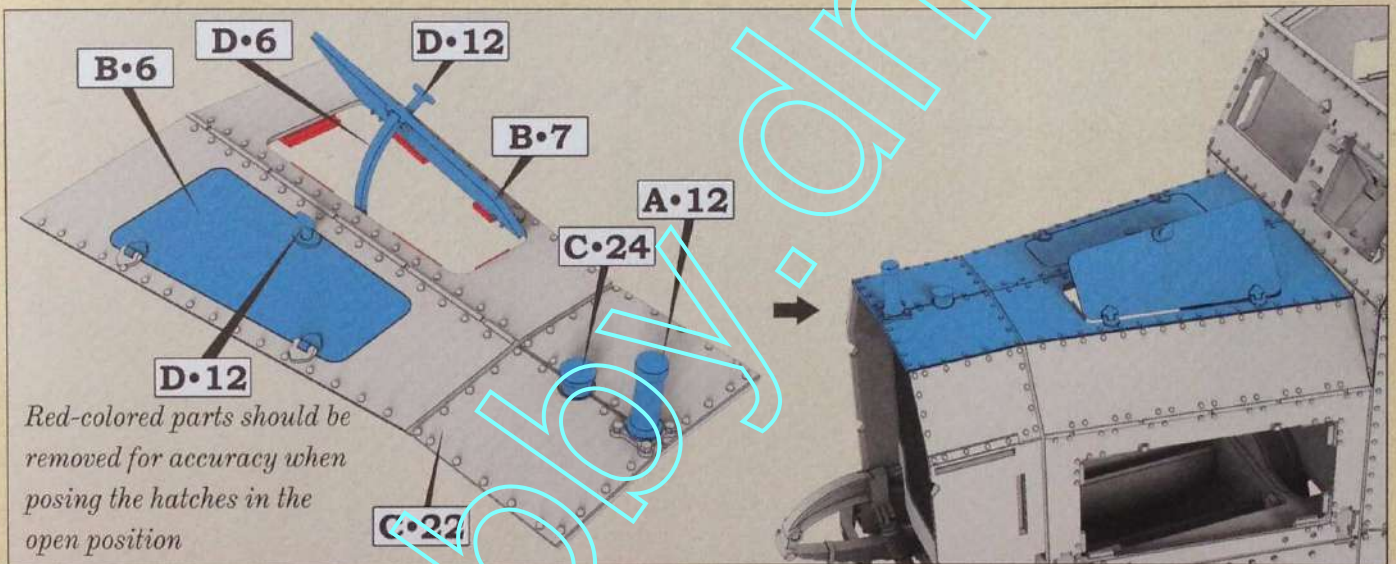

Step 21. Assembling and installation of the armoured hood

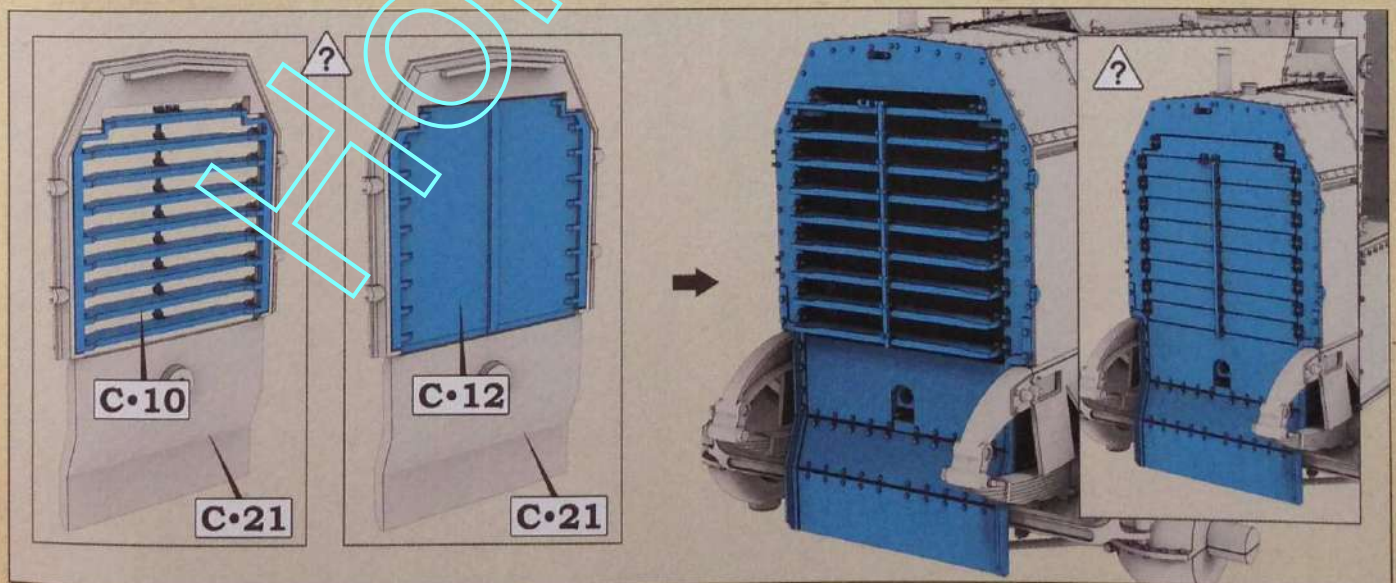

Step 22. Assembling and installing the front radiator protection

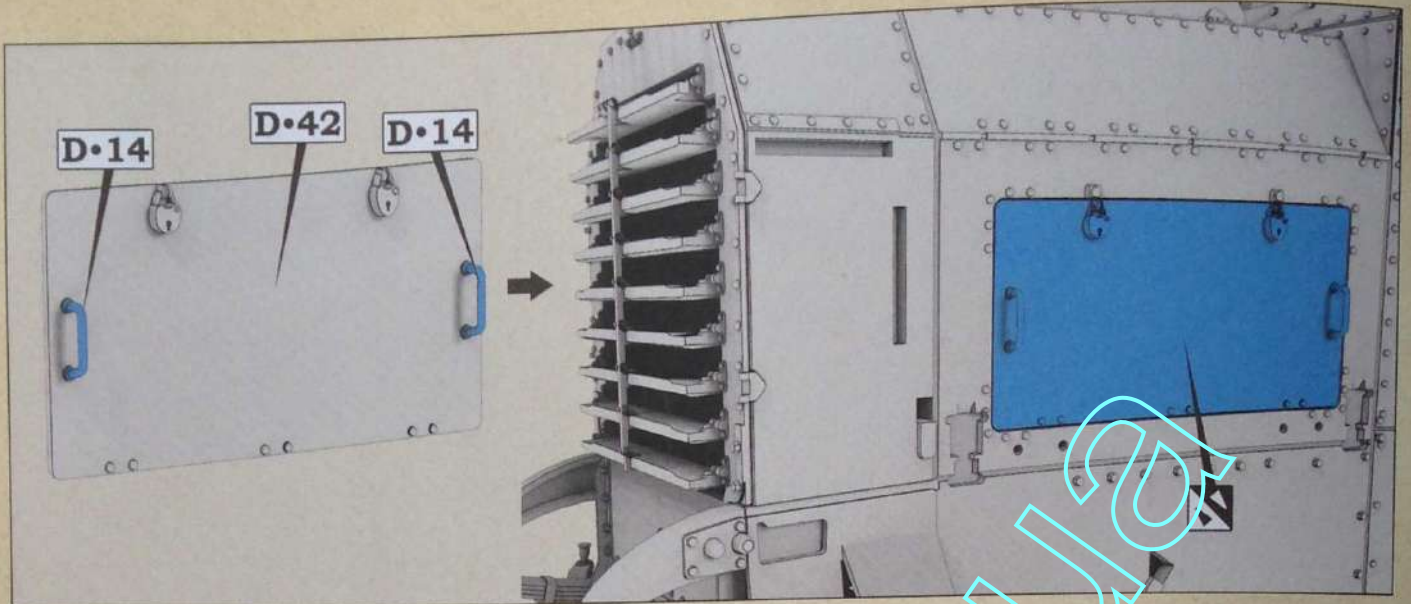

Step 23. Installing the engine panels on both sides

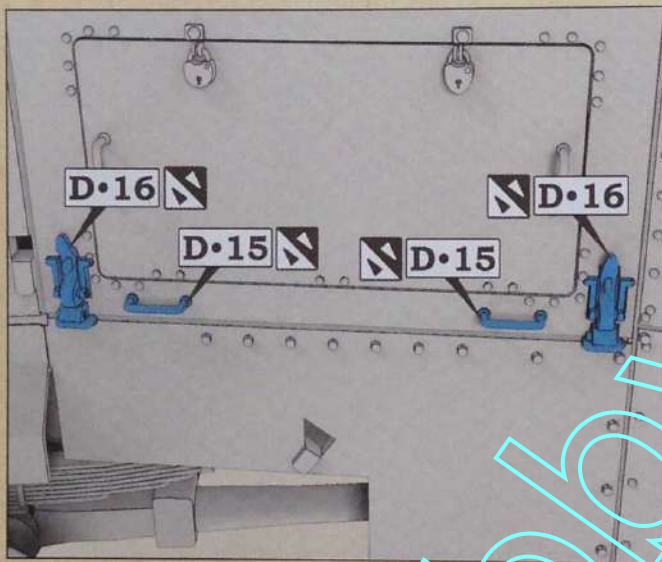

Step 24. Installation of the handles and panel locks

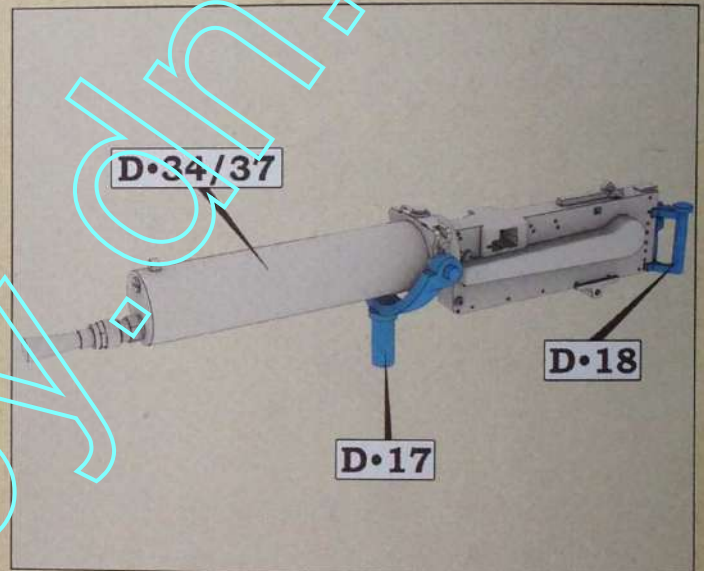

Step 25. Assembling the Maschinengewehr 08.
Make four

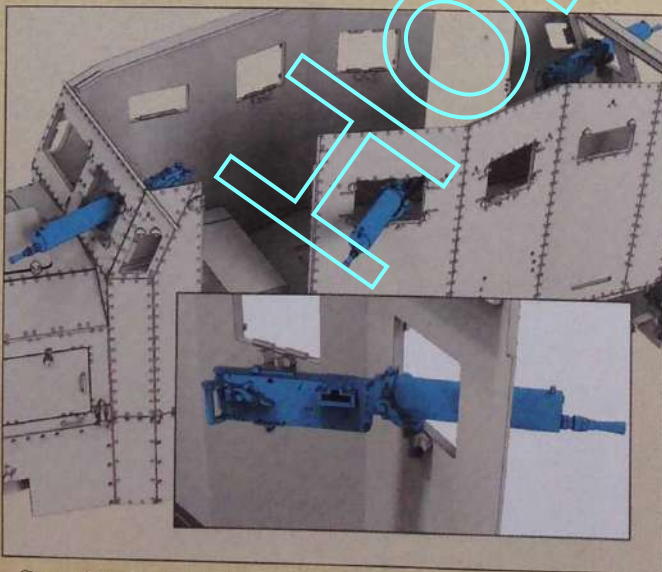

Step 26. Installation of the Maschinengewehr 08

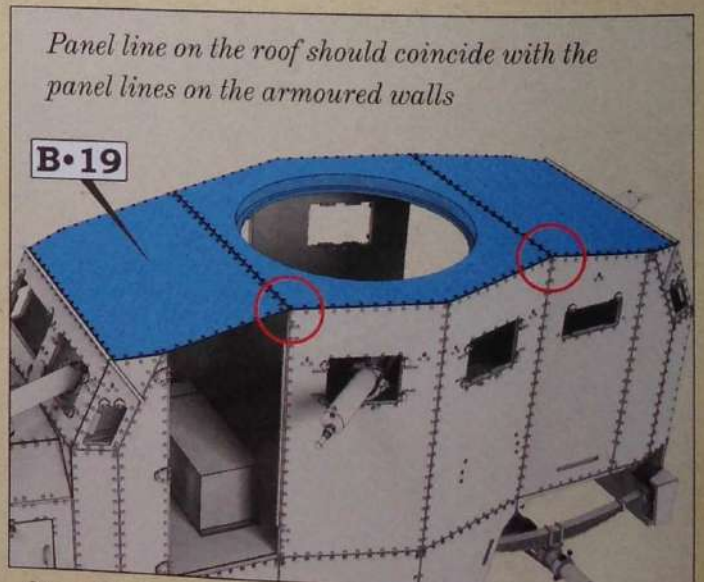

Step 27. Installation of the armoured roof

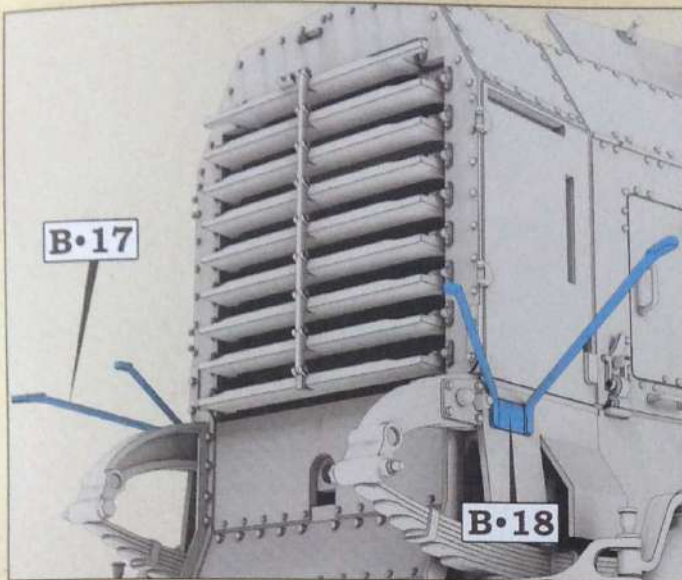

Step 28. Installation of the front fender mounts

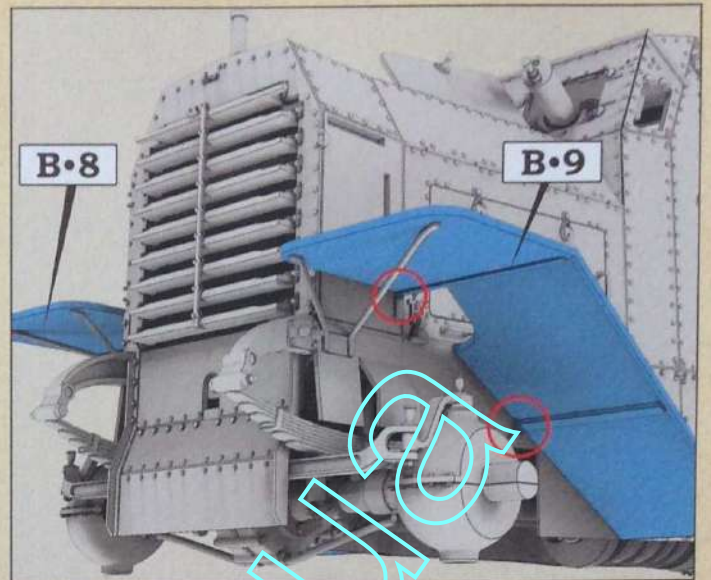

Step 29. Installation of the front fenders

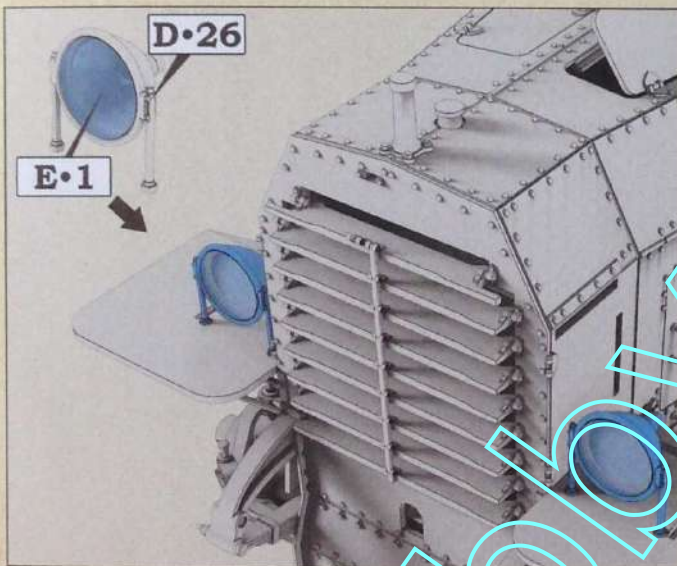

Step 30. Installation of the headlamps

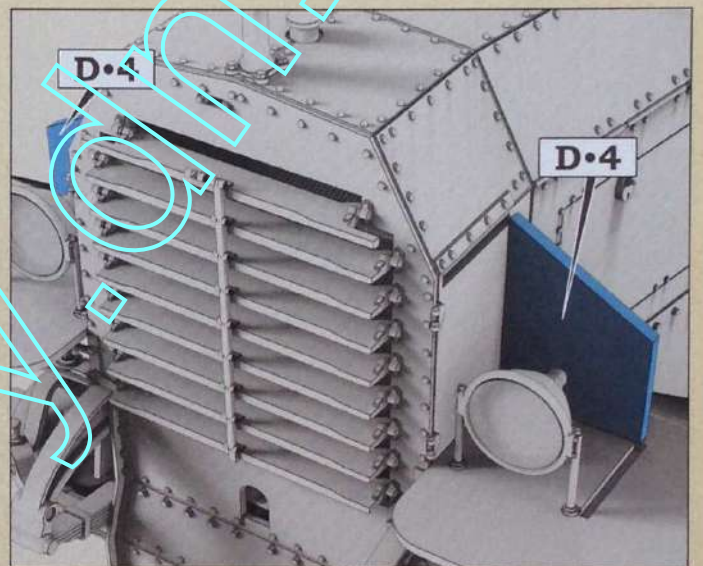

Step 31. Installation of the headlamps rear protection

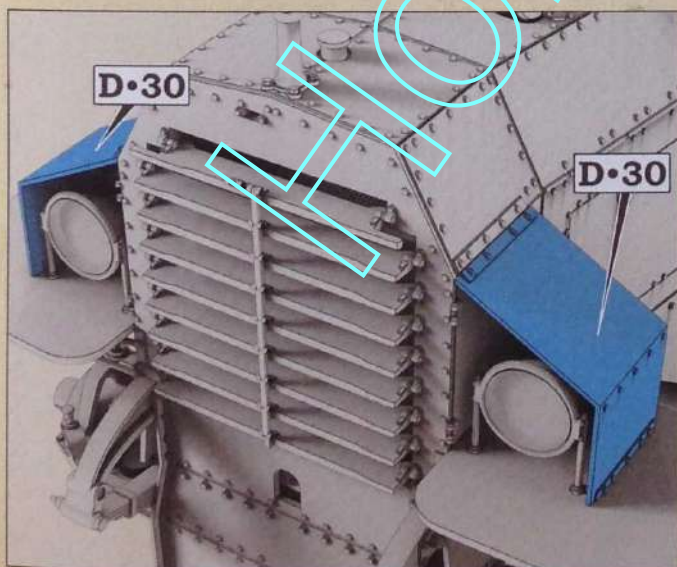

Step 32. Installation of the headlamps armoured cover

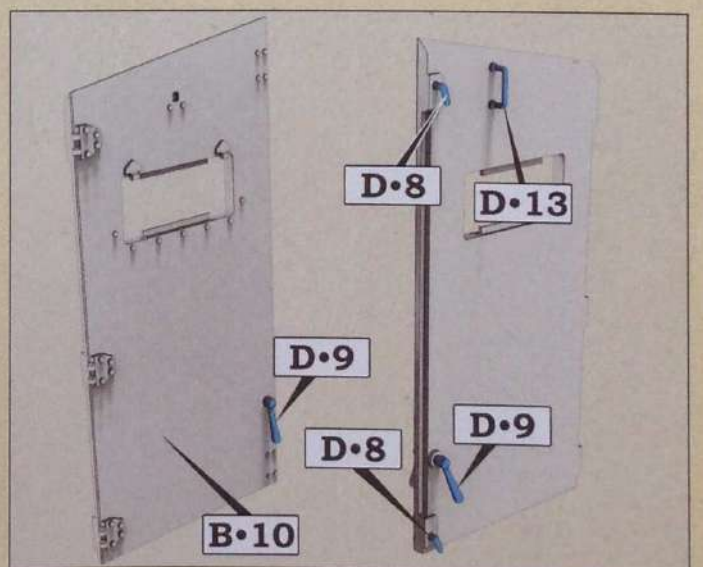

Step 33. Assembling the rear door

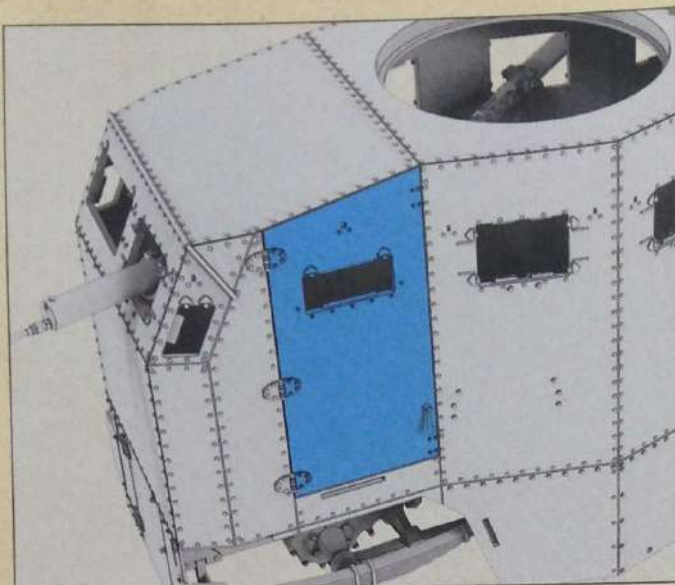

Step 34. Installation of the rear door

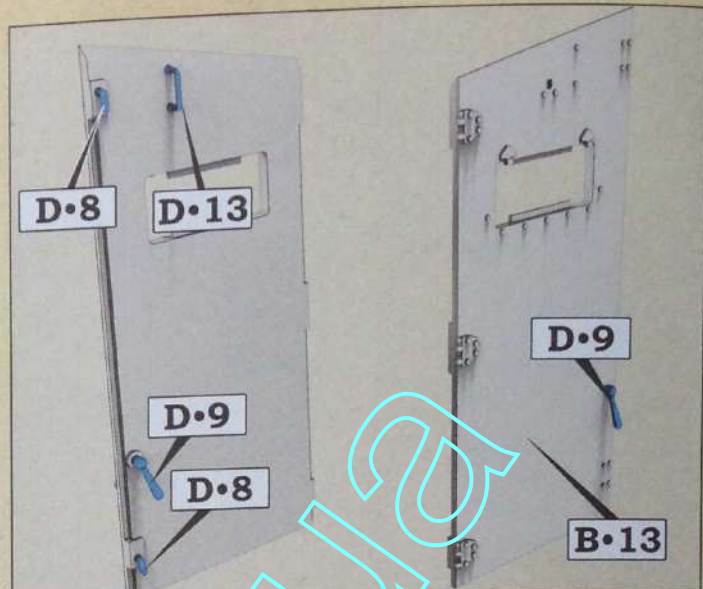

Step 35. Assembling the front door

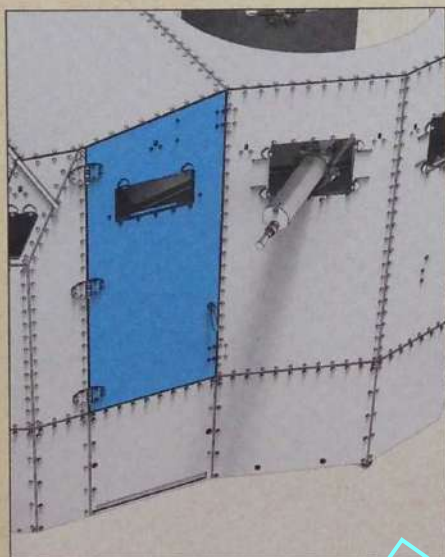

Step 36. Installation of the front door

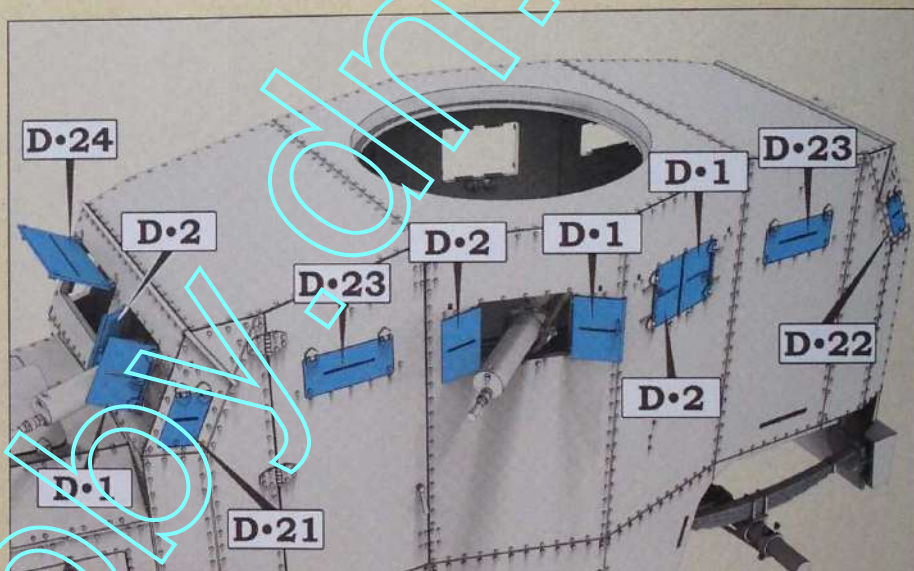

Step 37. Installation of the front and port shutters

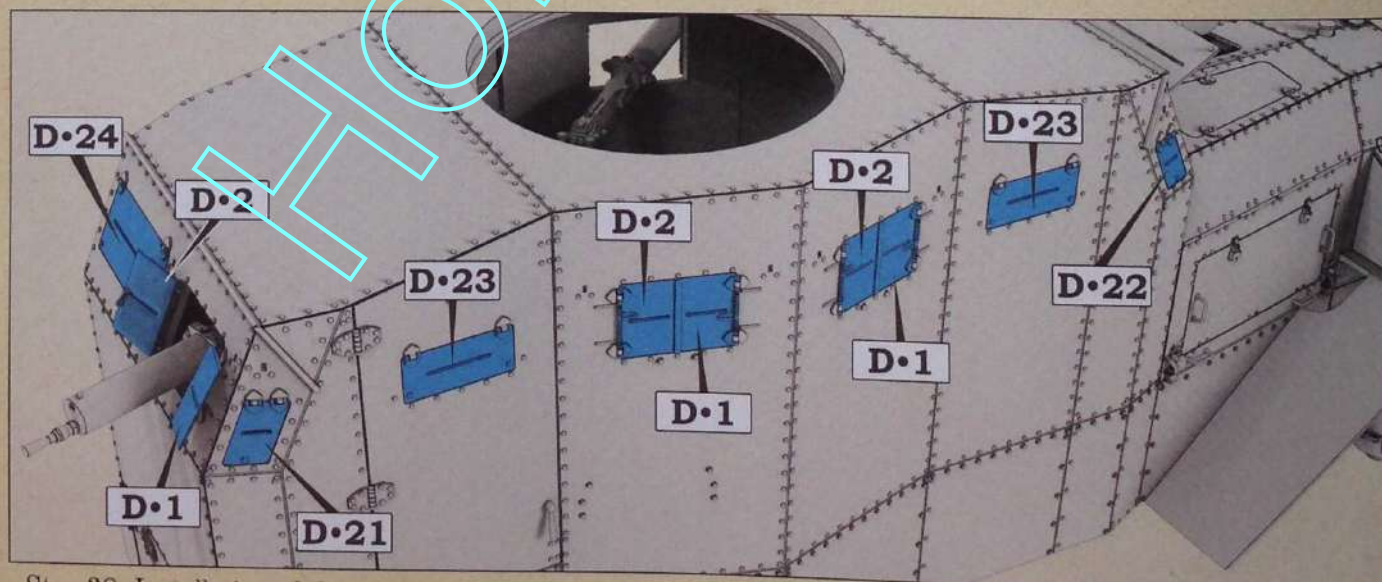

Step 38. Installation of the rear and starboard shutters

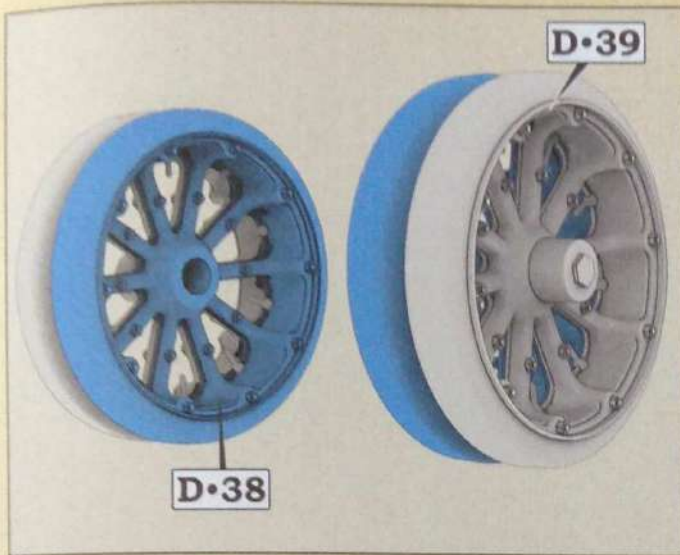

Step 39. Assembling the rear wheels, make two

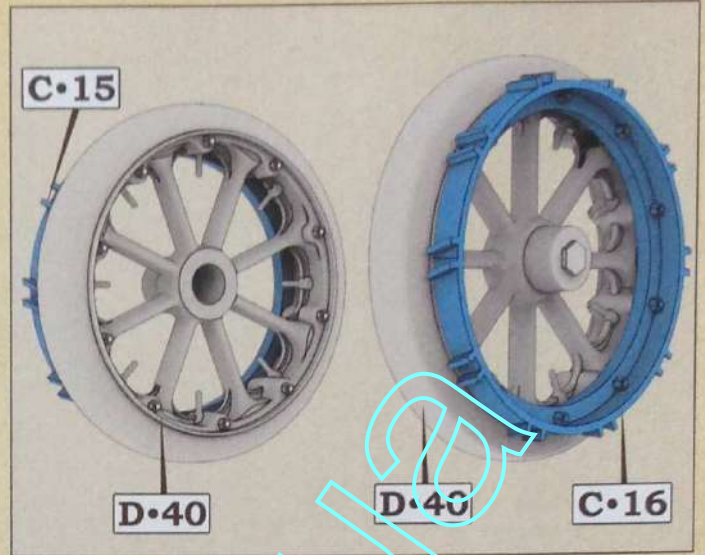

Step 40. Assembling the front wheels with grousers, mind the direction of the grousers for each side

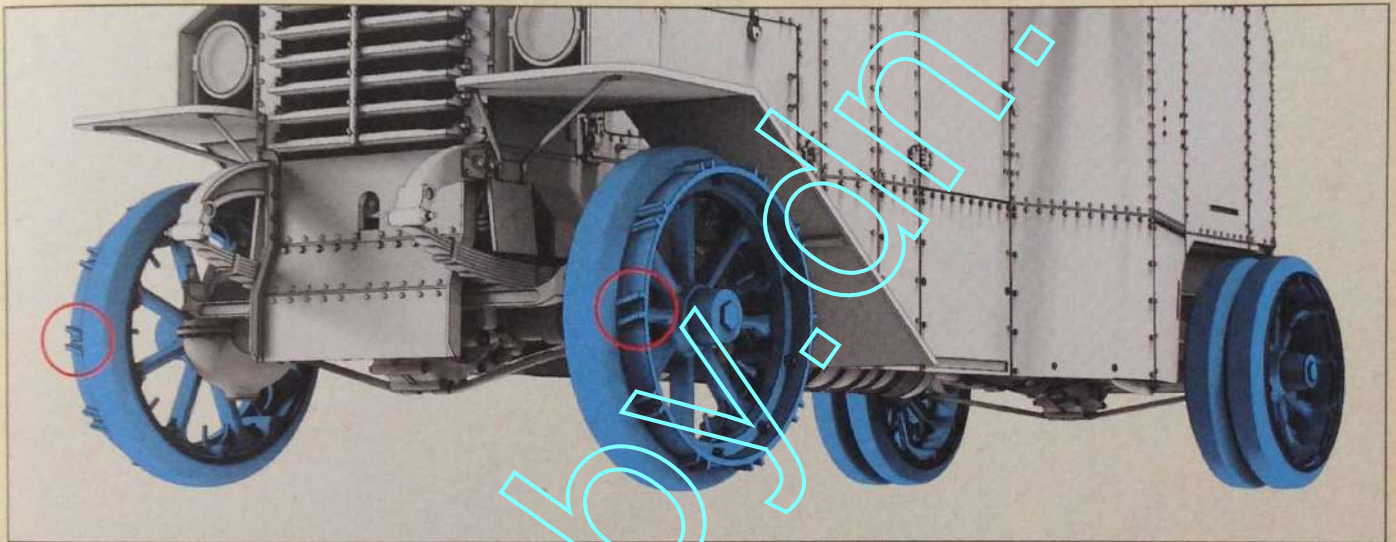

Step 41. Installing the wheels

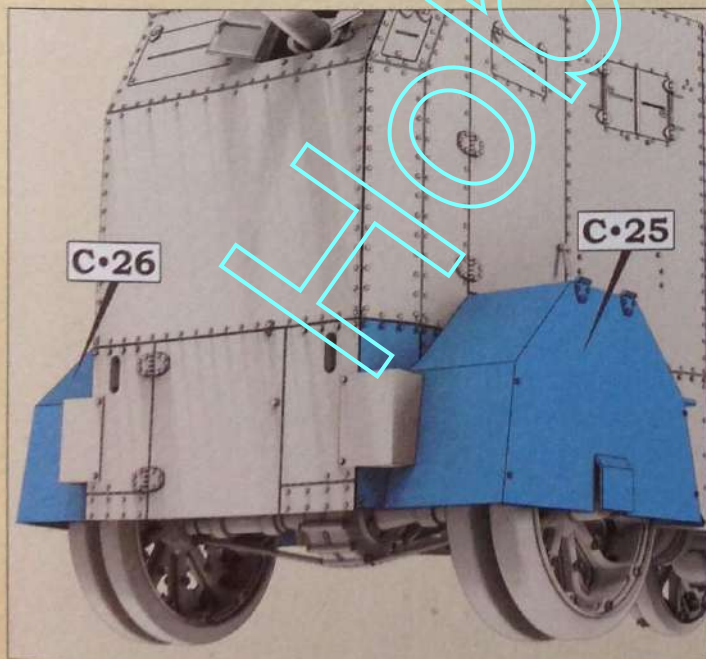

Step 42. Installing the rear fenders

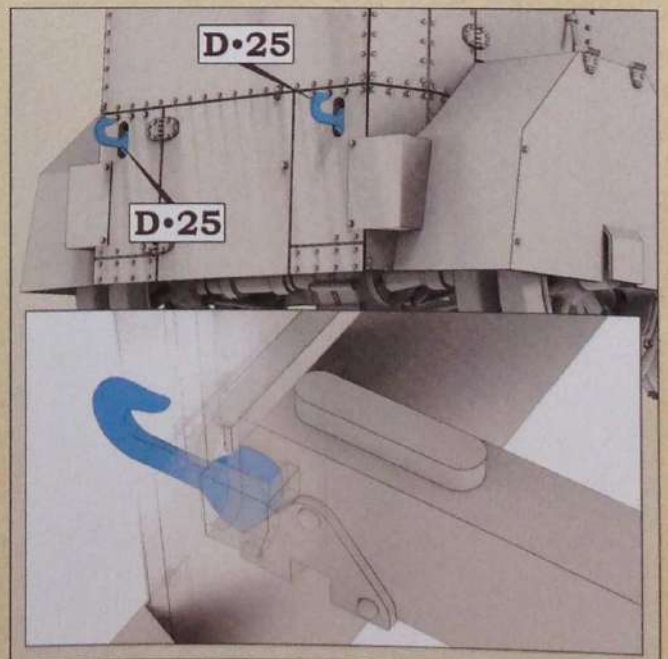

Step 43. Installation of the towing hooks

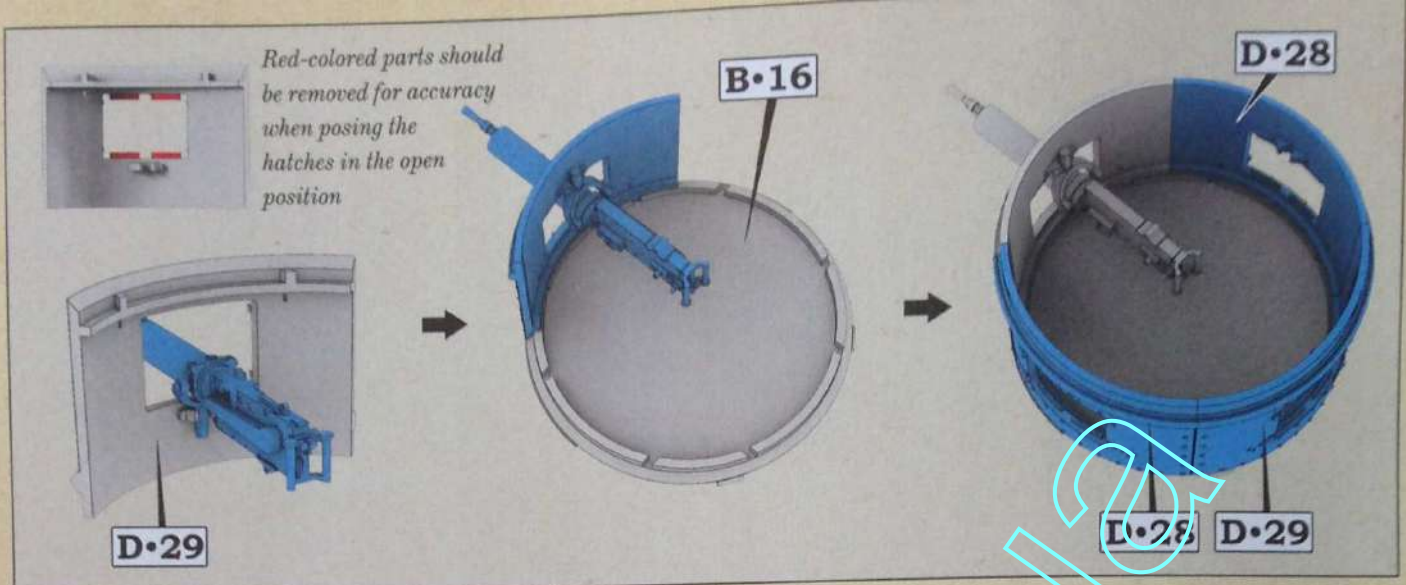

Step 44. Assembling the turret

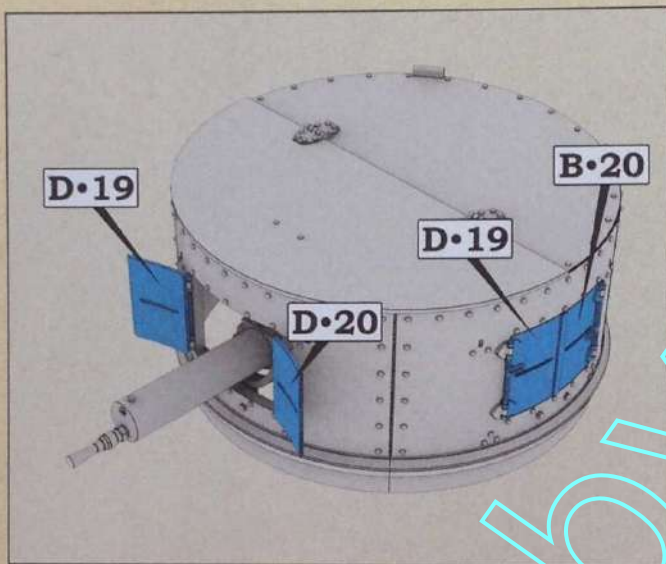

Step 45. Installation of the turret shutters on all four hatches

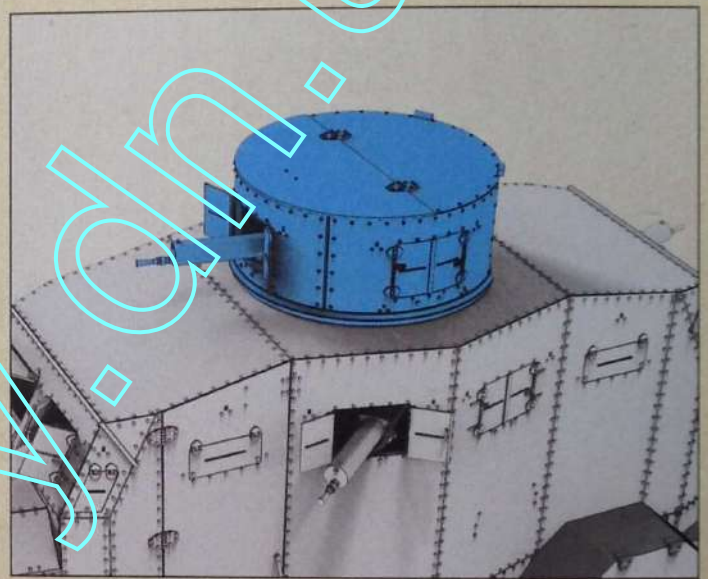

Step 46. Installation of the turret hatches

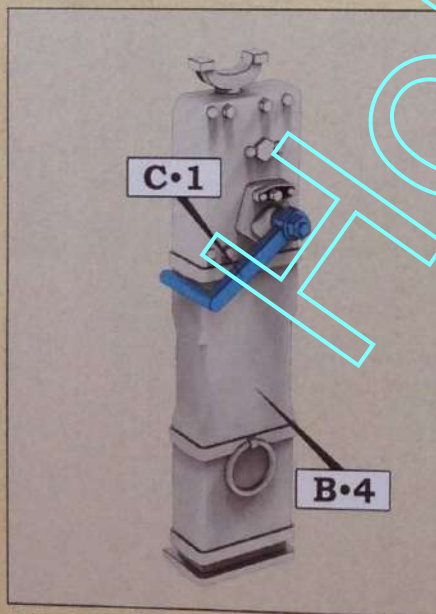

Step 47. Assembling the jack

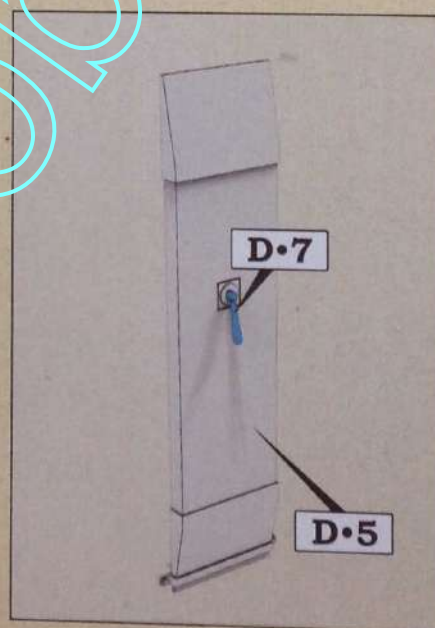

Step 48. Assembling the ditching board, make two

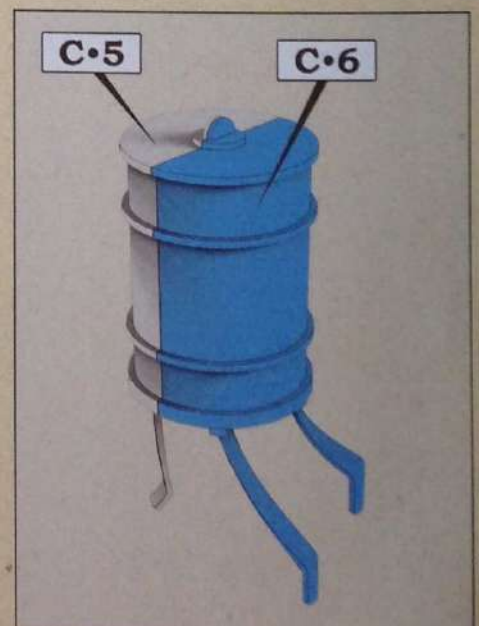

Step 49. Assembling the additional device

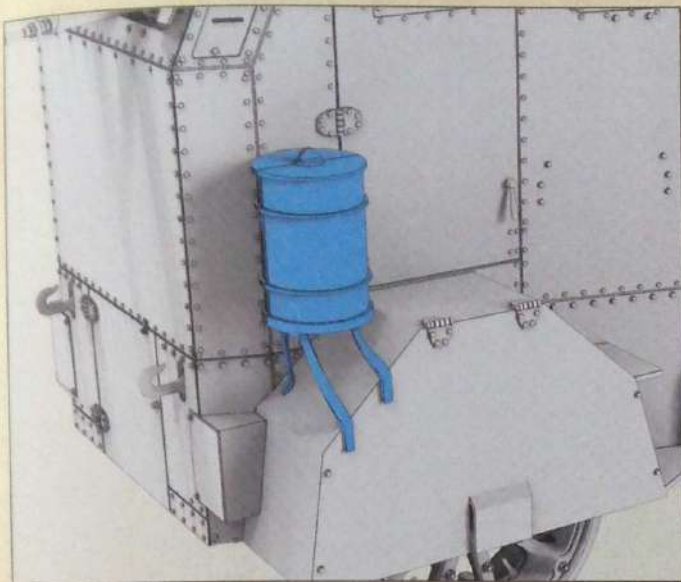

Step 50. Installation of the additional device. Check your markings, if this part was installed

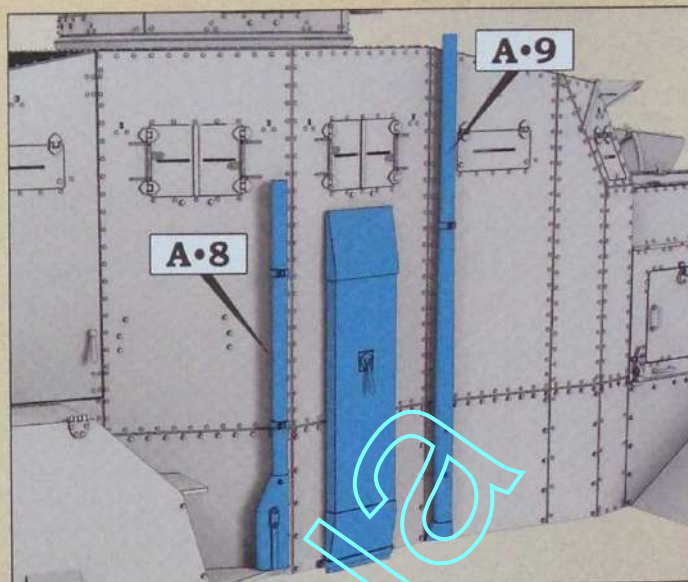

Step 51. Installation of the ditching board and antenna housings. Check your markings, if and where these parts were installed

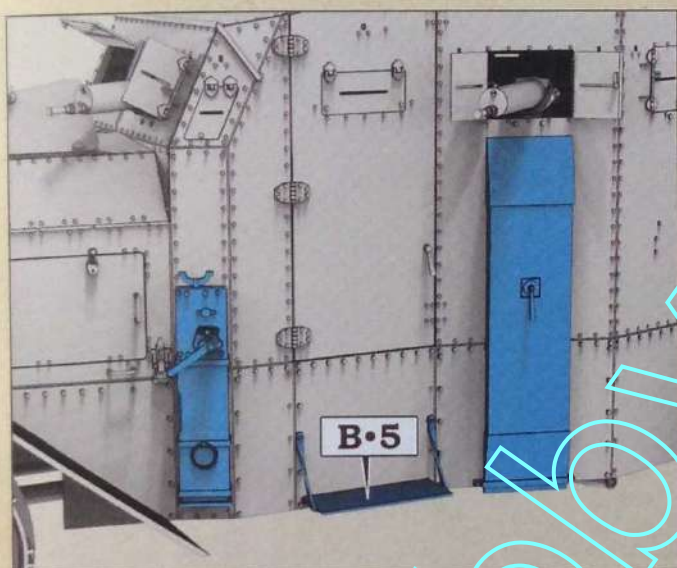

Step 52. Installation of the jack (check your markings), ditching board and the driver step

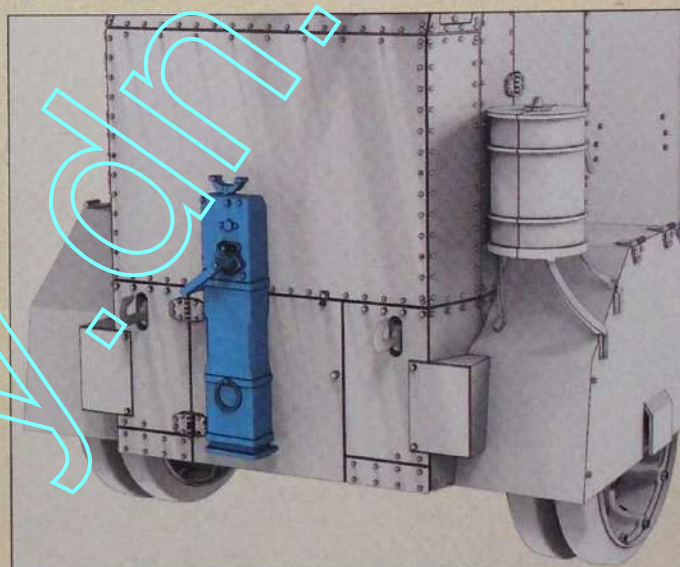

Step 53. Installation of the jack. Only for the "Griep-to" markings page 21

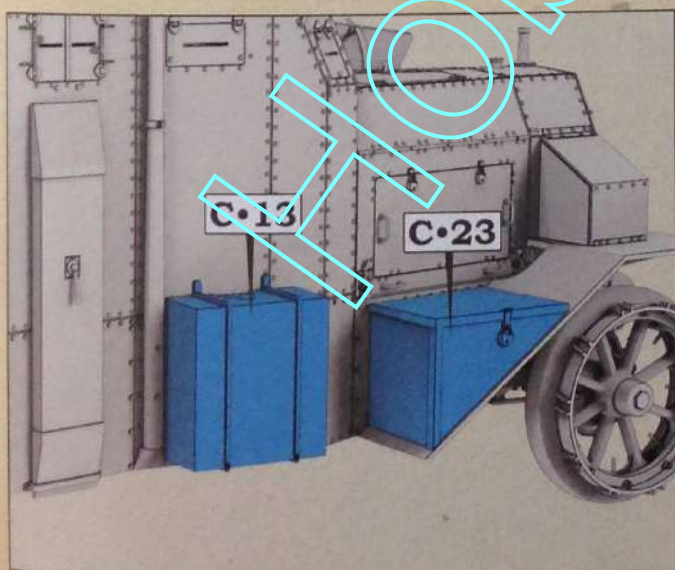

Step 54. Installation of the stowage boxes. Check your markings, if these parts were installed

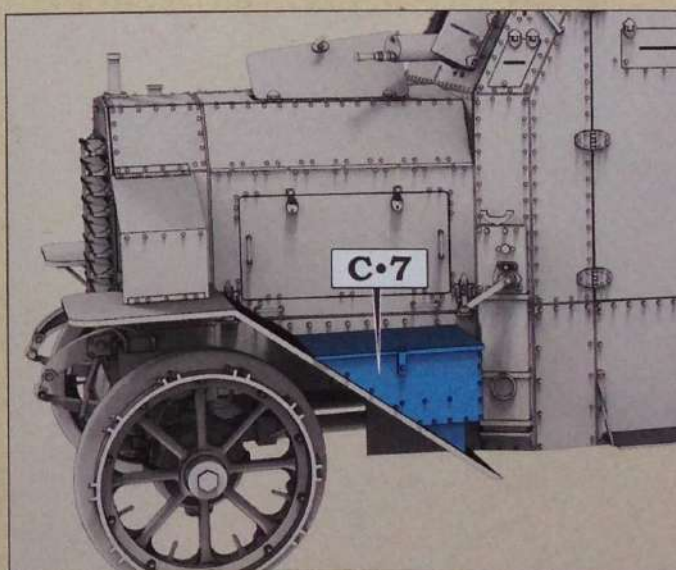

Step 55. Installation of the stowage boxes. Check your markings, if this part was installed

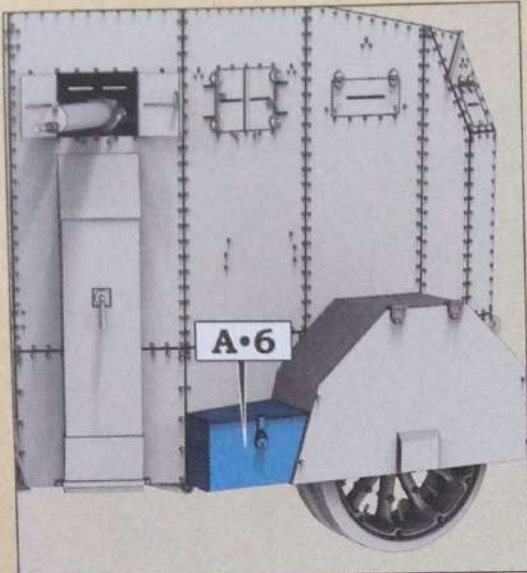

Step 56. Installation of the storage box. Check your markings, if this part was installed

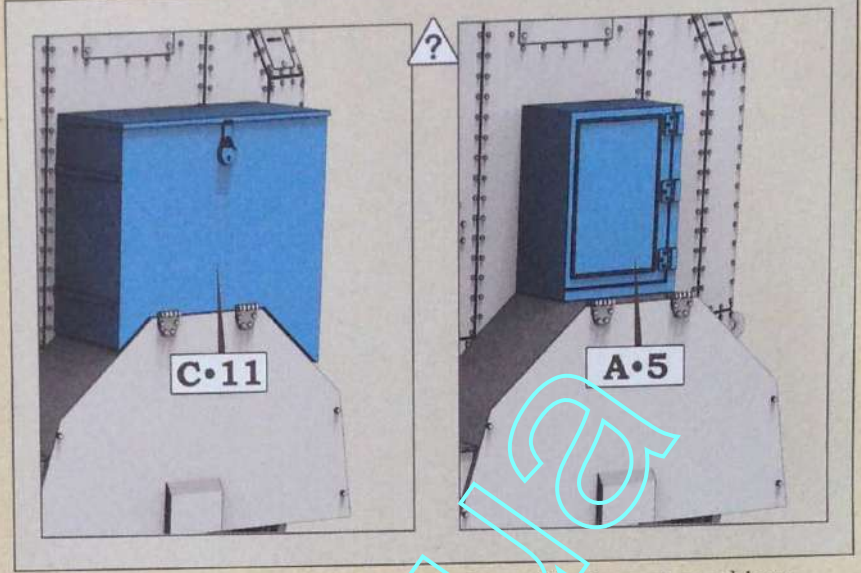

Step 57. Installation of the storage box. Check your markings, which part was installed

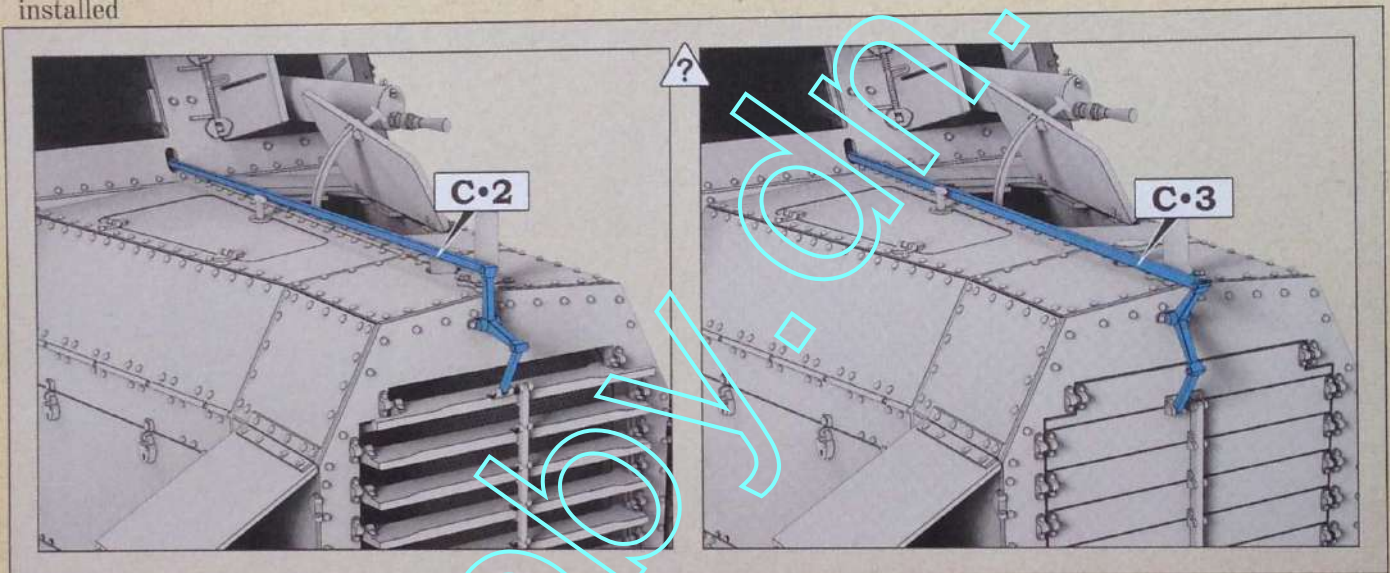

Step 58. Installation of the radiator shutter rod

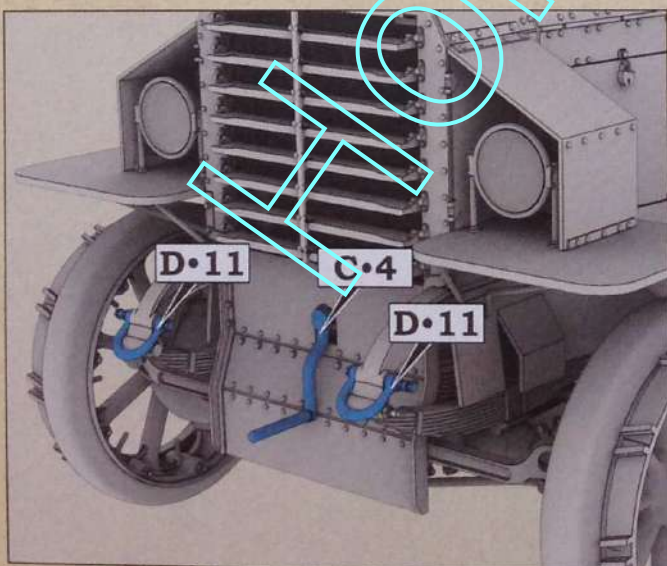

Step 59. Installing the towing lugs and the hand crank

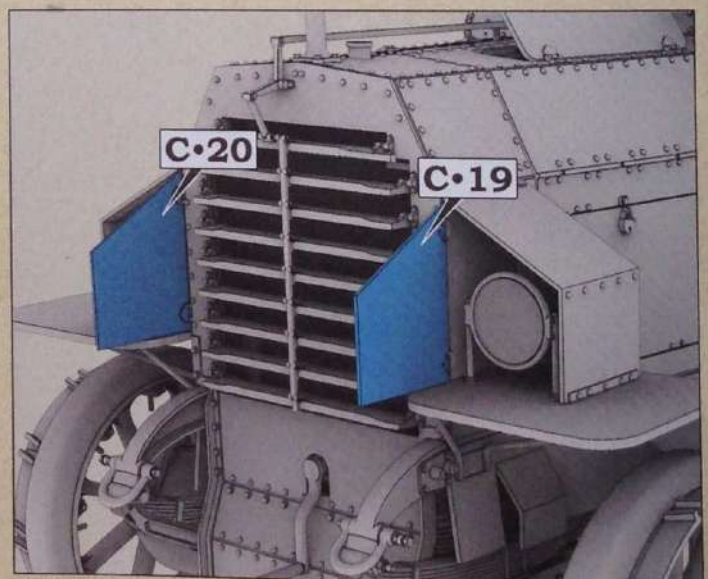

Step 60. Installation of the headlamp shutters

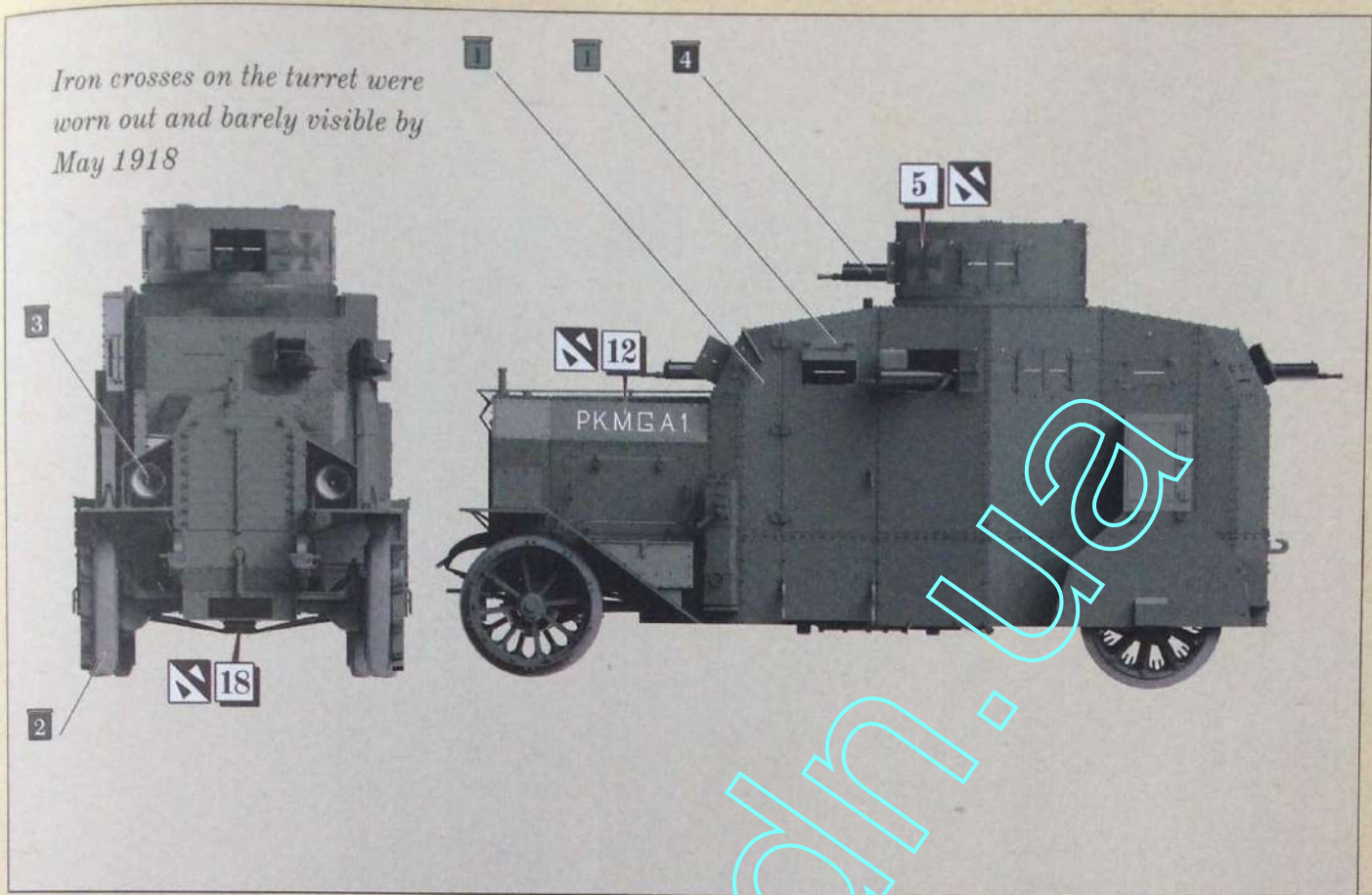

Fig. 7. Ehrhardt P.K.M.G.A.1 of the 1st Machine Gun Platoon. Was captured by the Red Army, Kozinki area in May 1918

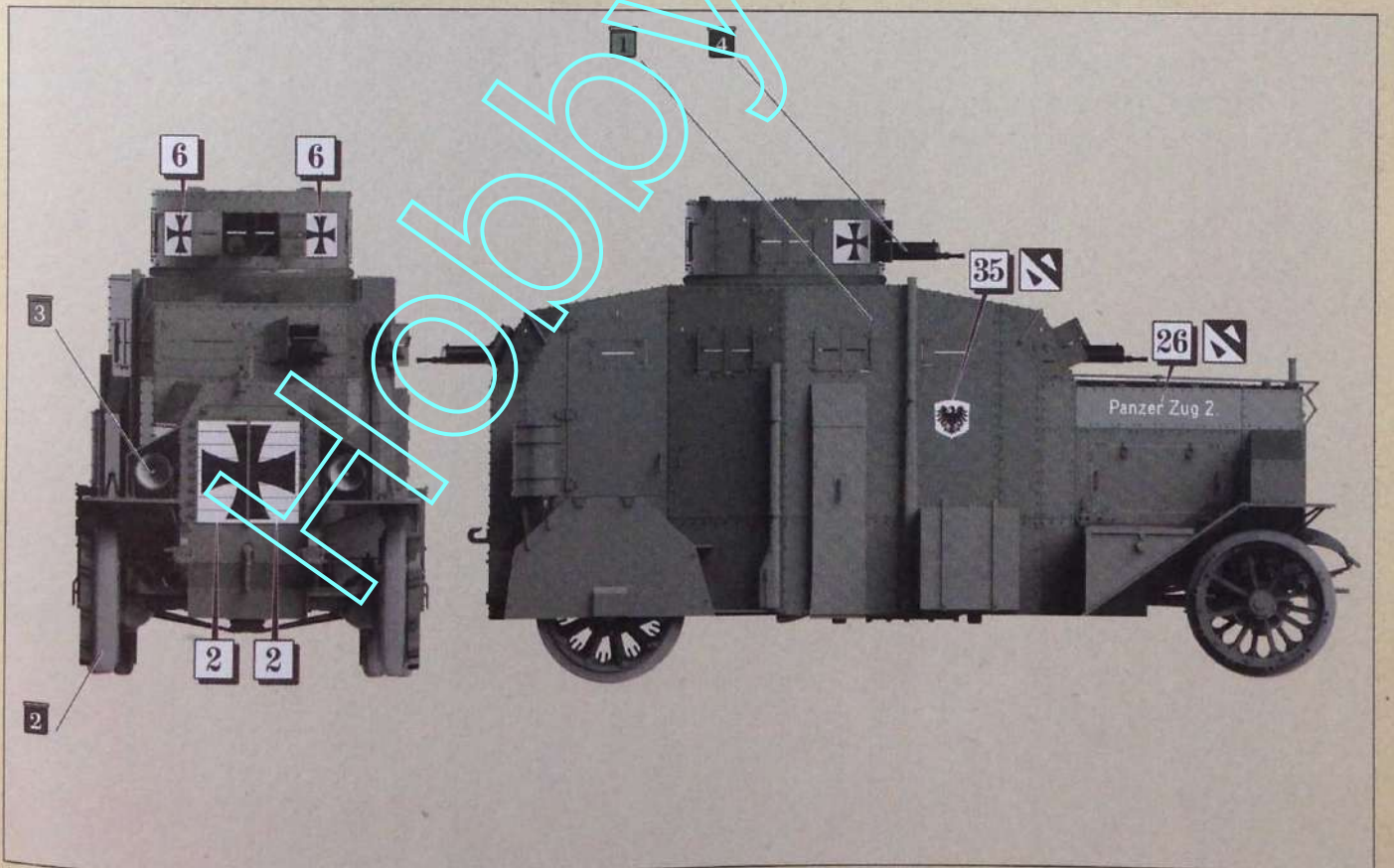

Fig. 8. Ehrhardt from the 2nd platoon before it was repainted. German occupation forces in Ukraine.

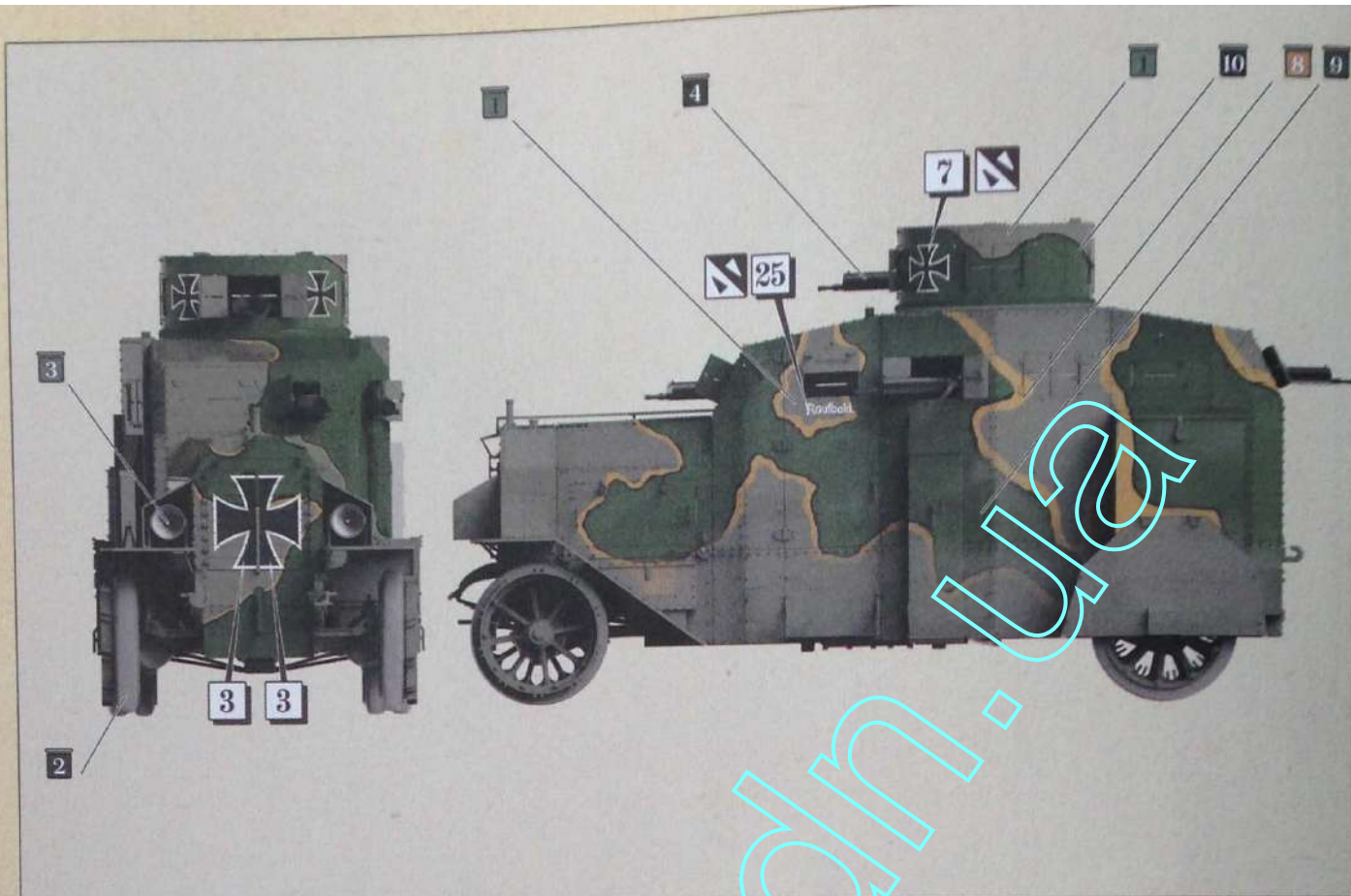

Fig. 9. Ehrhardt from the 2nd platoon named "Raufbold", camouflage was added while the platoon was stationed in Ukraine, summer 1918, and later in 1919 this Ehrhardt was captured by the Poles.

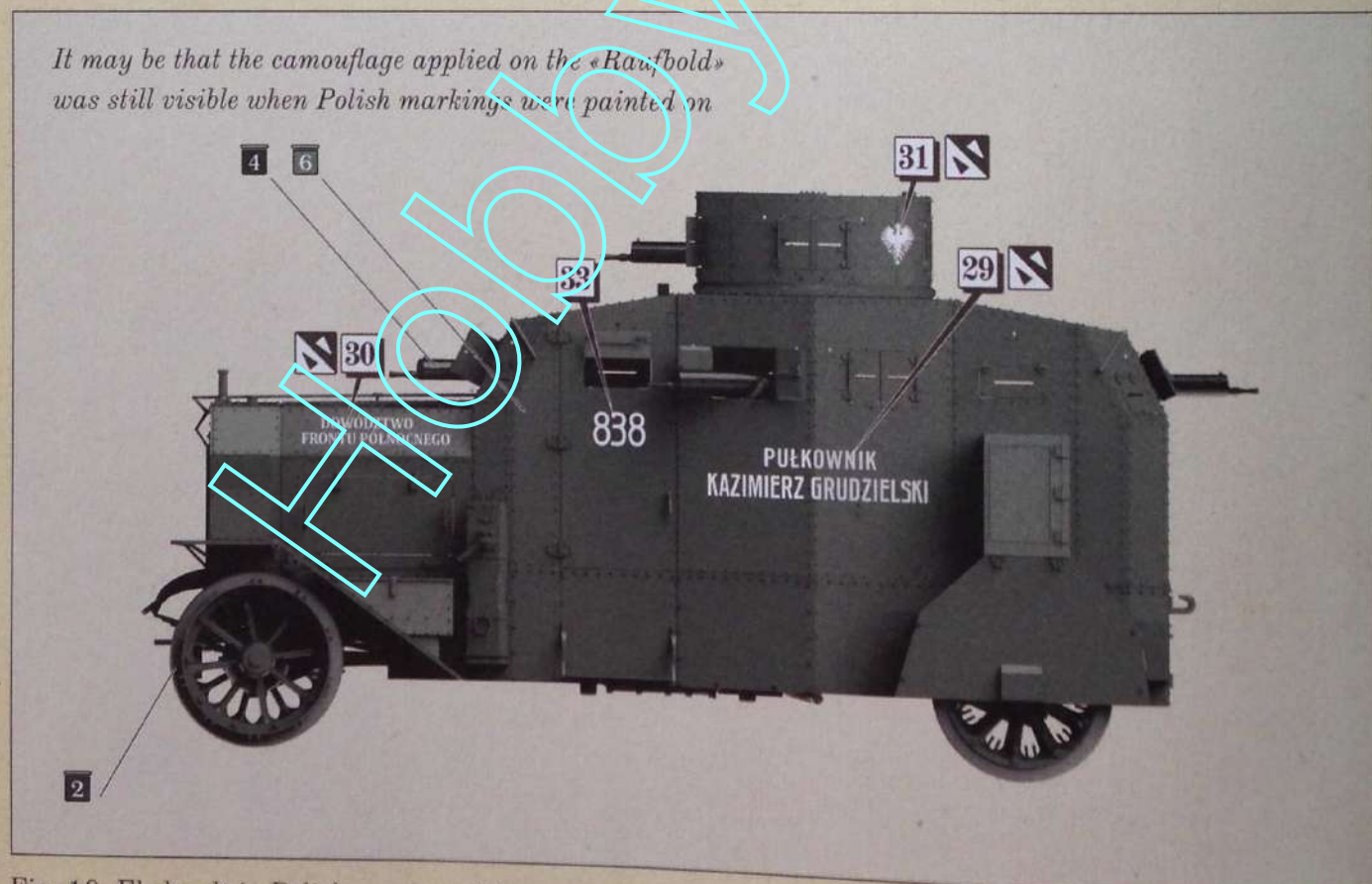

Fig. 10. Ehrhardt in Polish service with a name "Colonel Kasimierz Grudzielski" 1919.

The main colour is not known.
 But this Ehrhard was in Polish
 service for 2 years and was repainted
 at least several times by 1921.

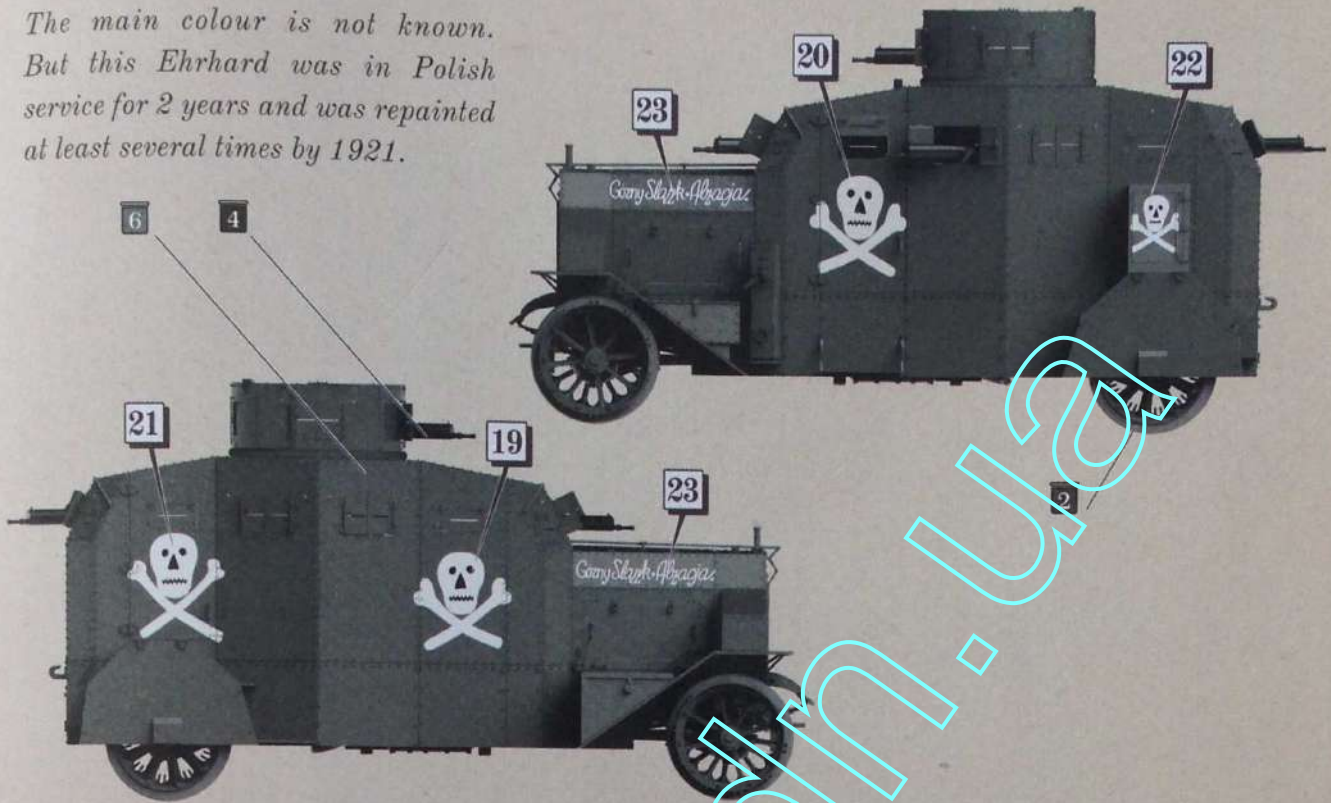

Fig. 11. Ehrhardt in Polish service. The name was changed to "Górný Śląsk - Alzacja" and saw action in the 3d Silesian Uprising in 1921

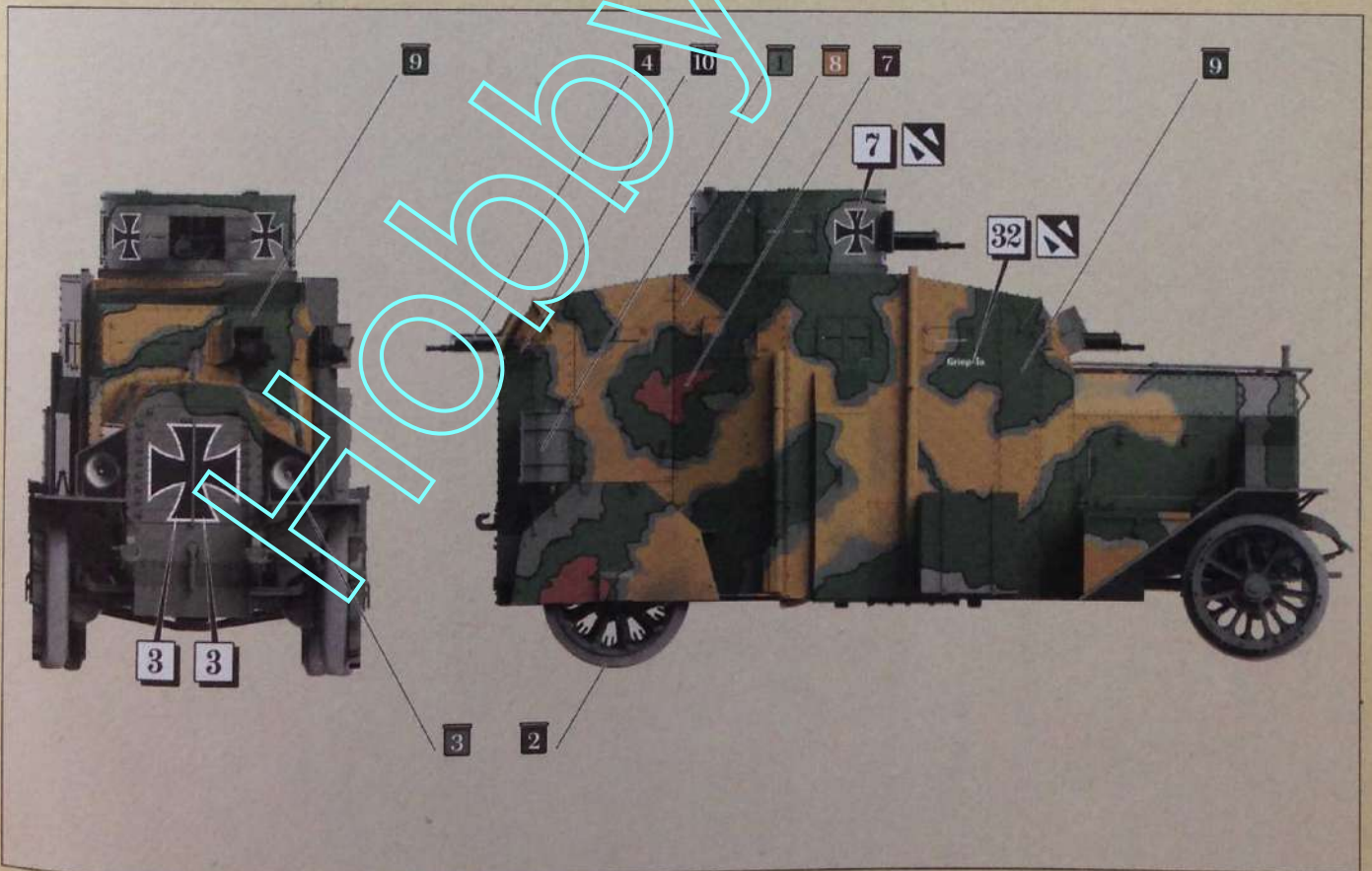

Fig. 12. Ehrhardt from the 2nd platoon - "Griep-to" during its stay in Ukraine, summer 1918

By the end of WWI, Germany suffered from lack of pigments. It may be that this Ehrhardt was repainted in grey colour.

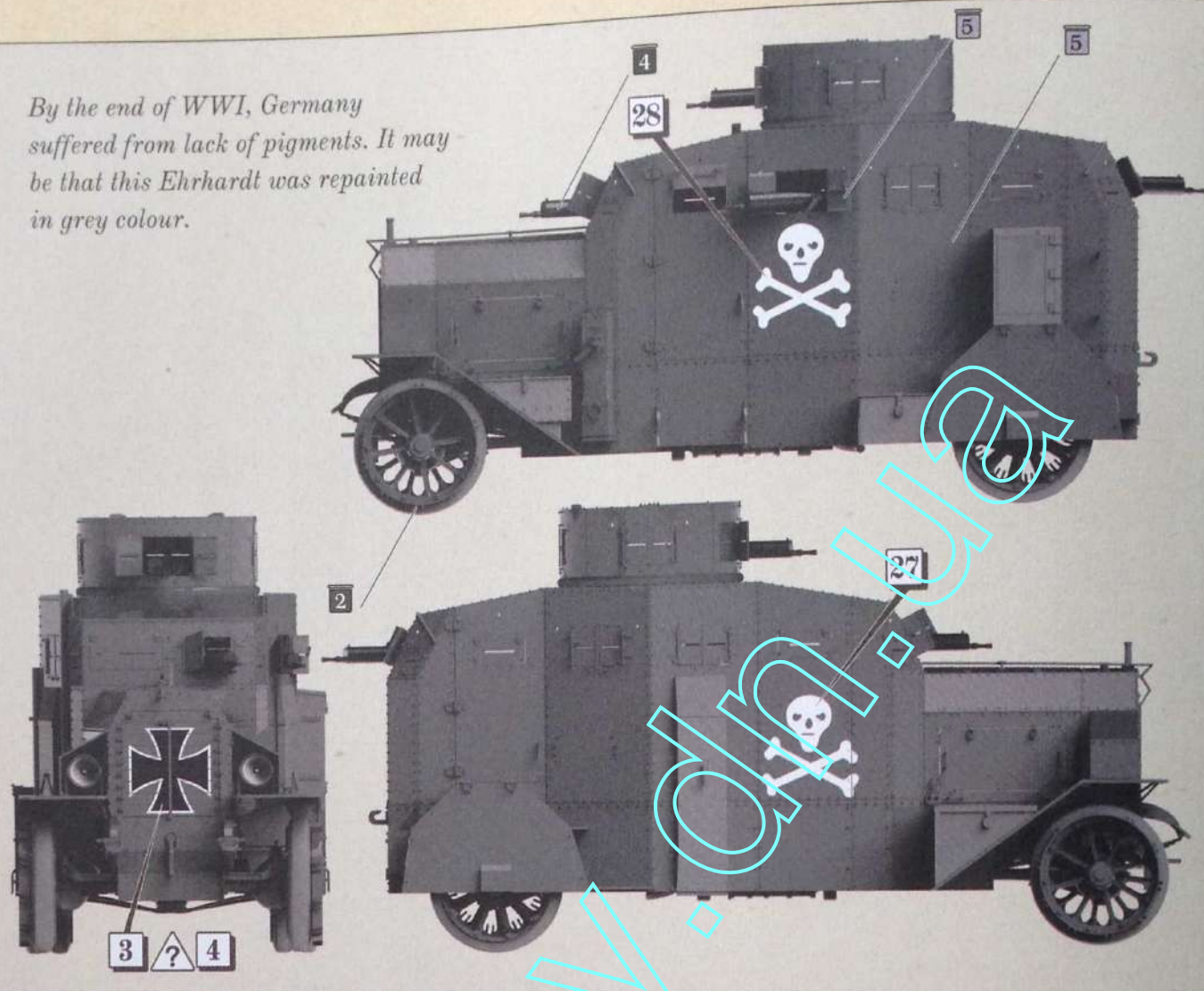

Fig. 13. An Ehrhardt Model 1917, previously known in the 2nd platoon under the name "Griep-to" as part of volunteers from the Lutwitz corps, Berlin, 1919

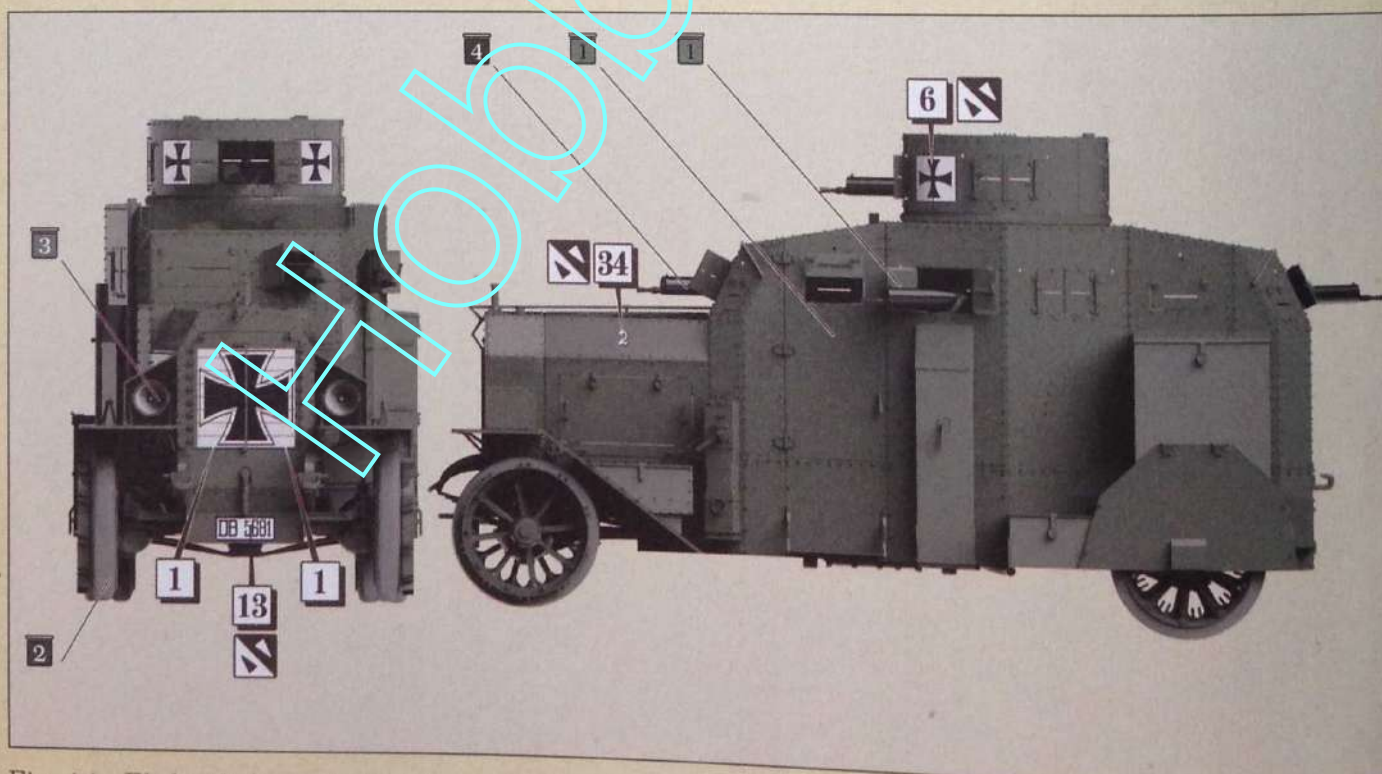

Fig. 14. Ehrhardt from the 3rd Armored Machine Gun Platoon in Rostov-on-Don, Russia, august 1918

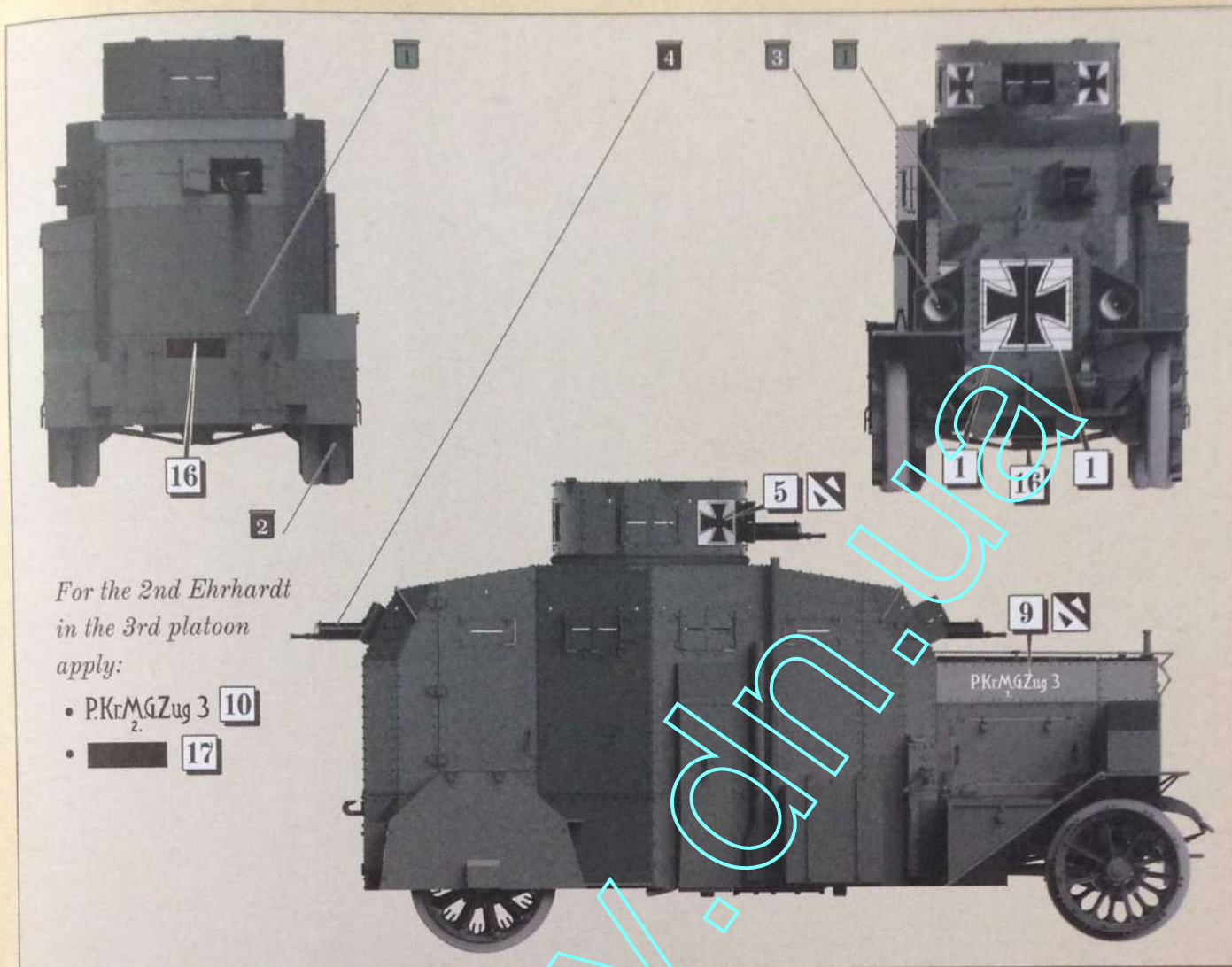

Fig. 15. Ehrhardt from the 3rd Armored Machine Gun Platoon. Registration numbers "K 2086" and "K 2087". The letter K stands for command of the 14th Army (A.O.K.14). November 27, Vittorio Veneto, Italy 1917

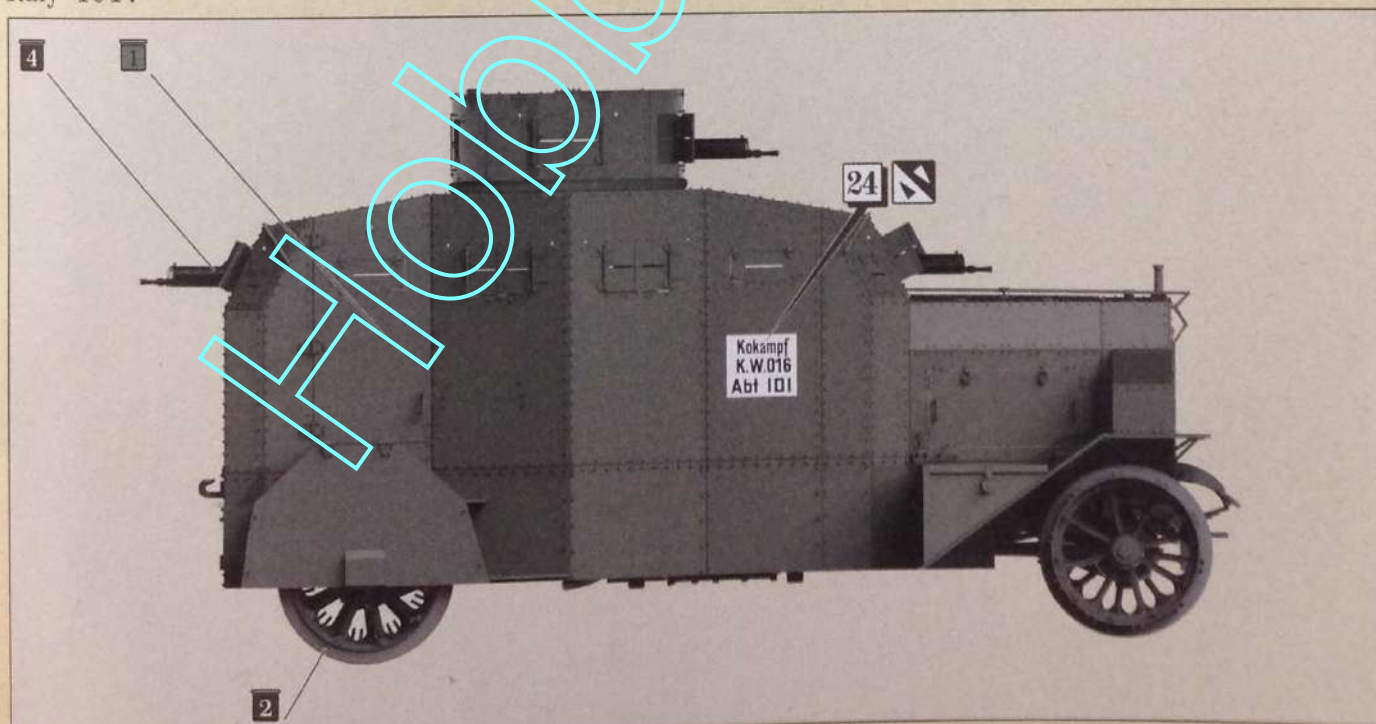

Fig. 16. Ehrhardt marked «Kokampf K.W.016, Abt .101» belonging to the 1st department of Georg Körting combat vehicles. Letters K.W. stands for "Combat Vehicle" (Kampfwagen). Berlin, 1919

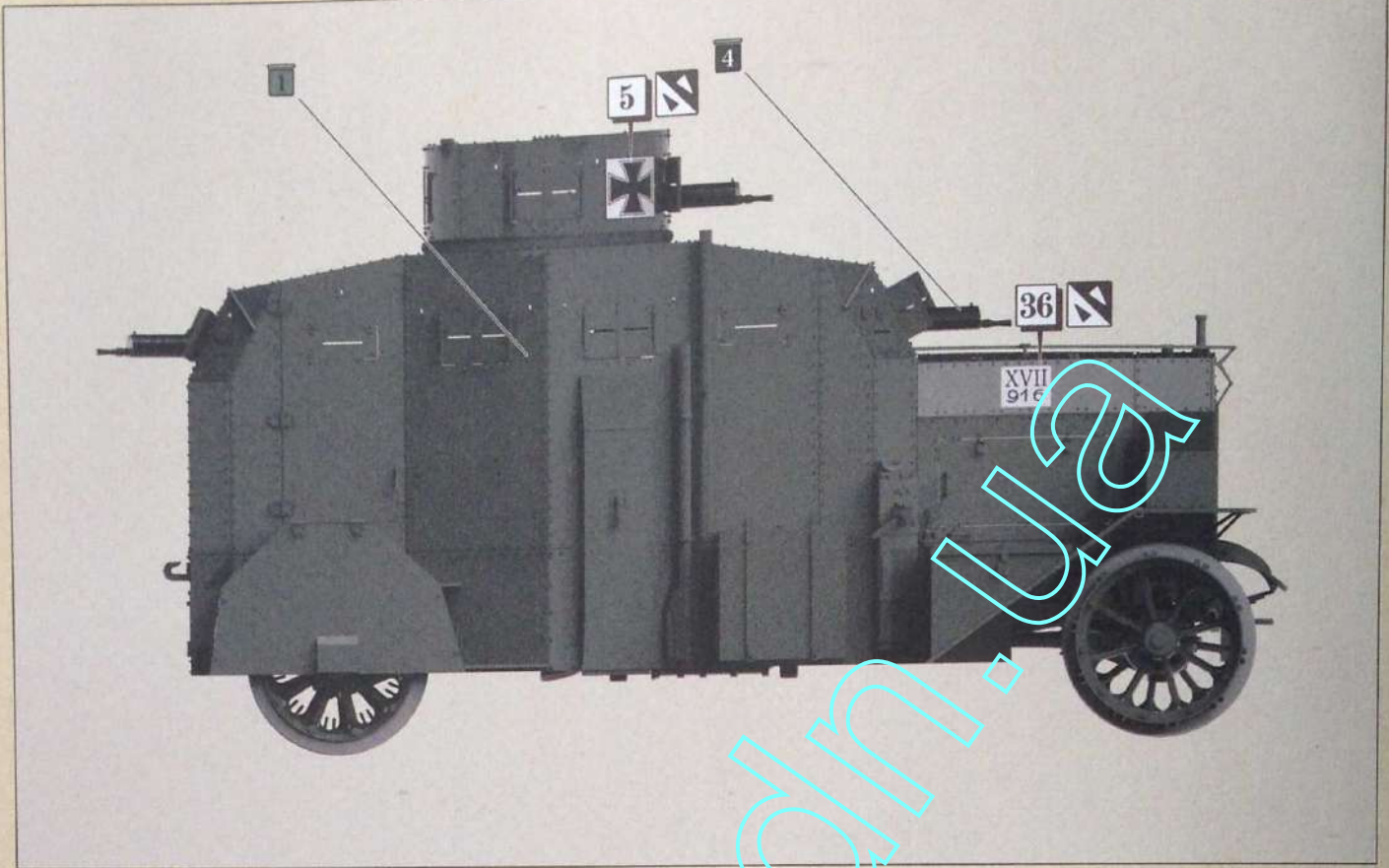

Fig. 17. Ehrhardt of the 17th Army, the former 14th, transferred from Italy to the Western Front. Flanders, Spring 1918

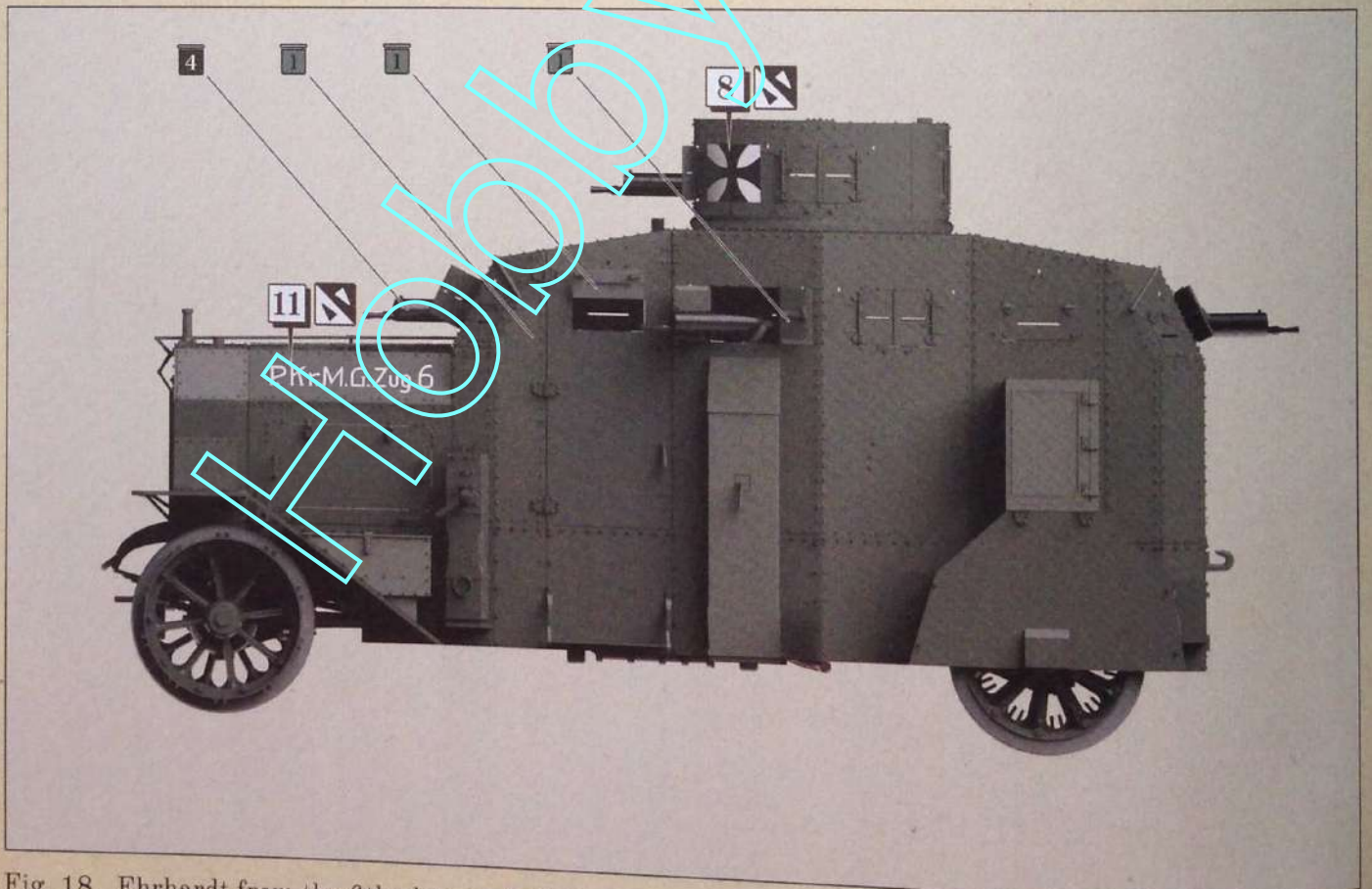

Fig. 18. Ehrhardt from the 6th platoon. Lake Peipsi, March 1918

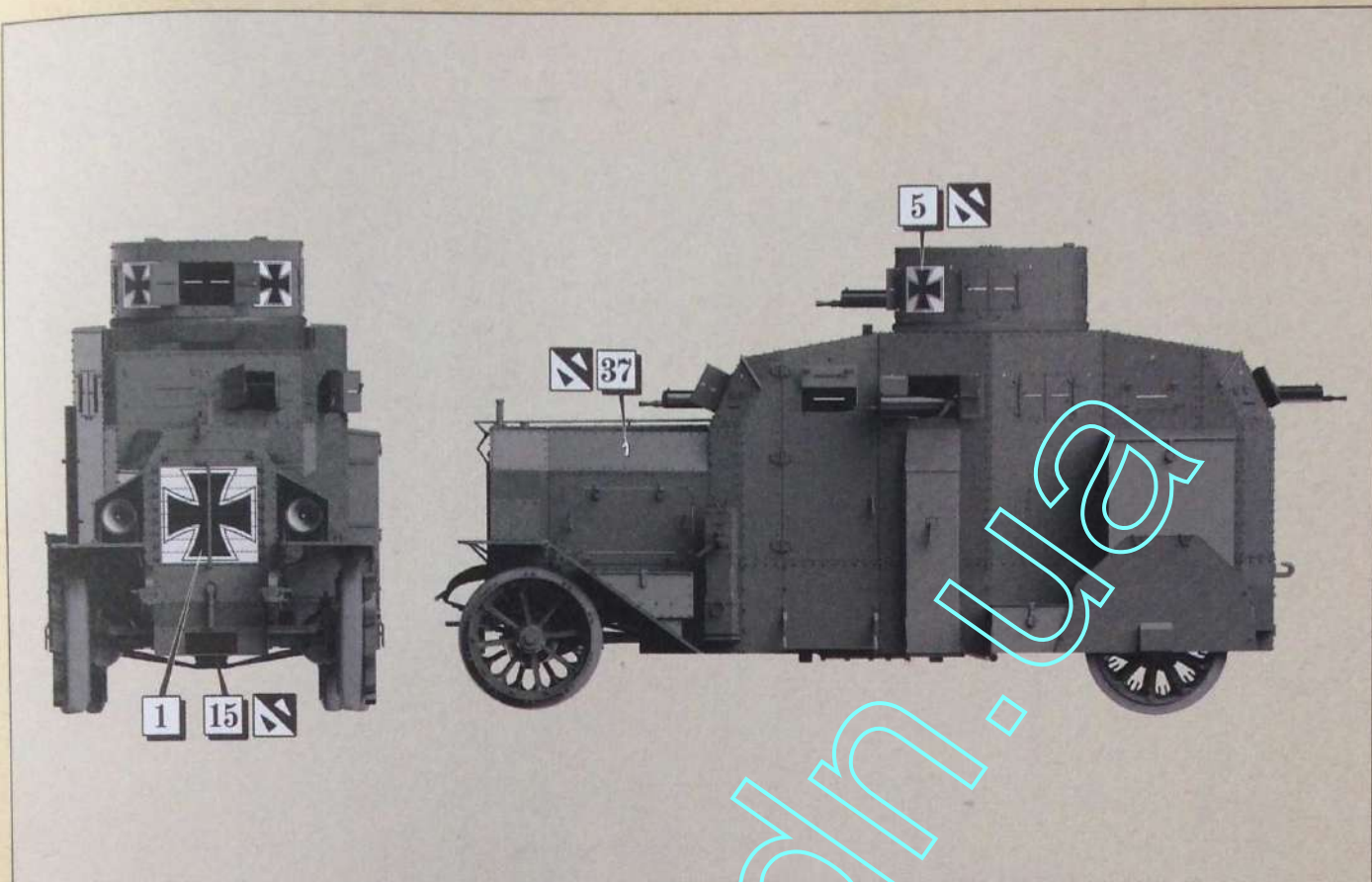

Fig. 19. Ehrhardt from the 3rd Armored Machine Gun Platoon. License plate B 7206, belonging to the Army Department "B". Alsace. November, 1918

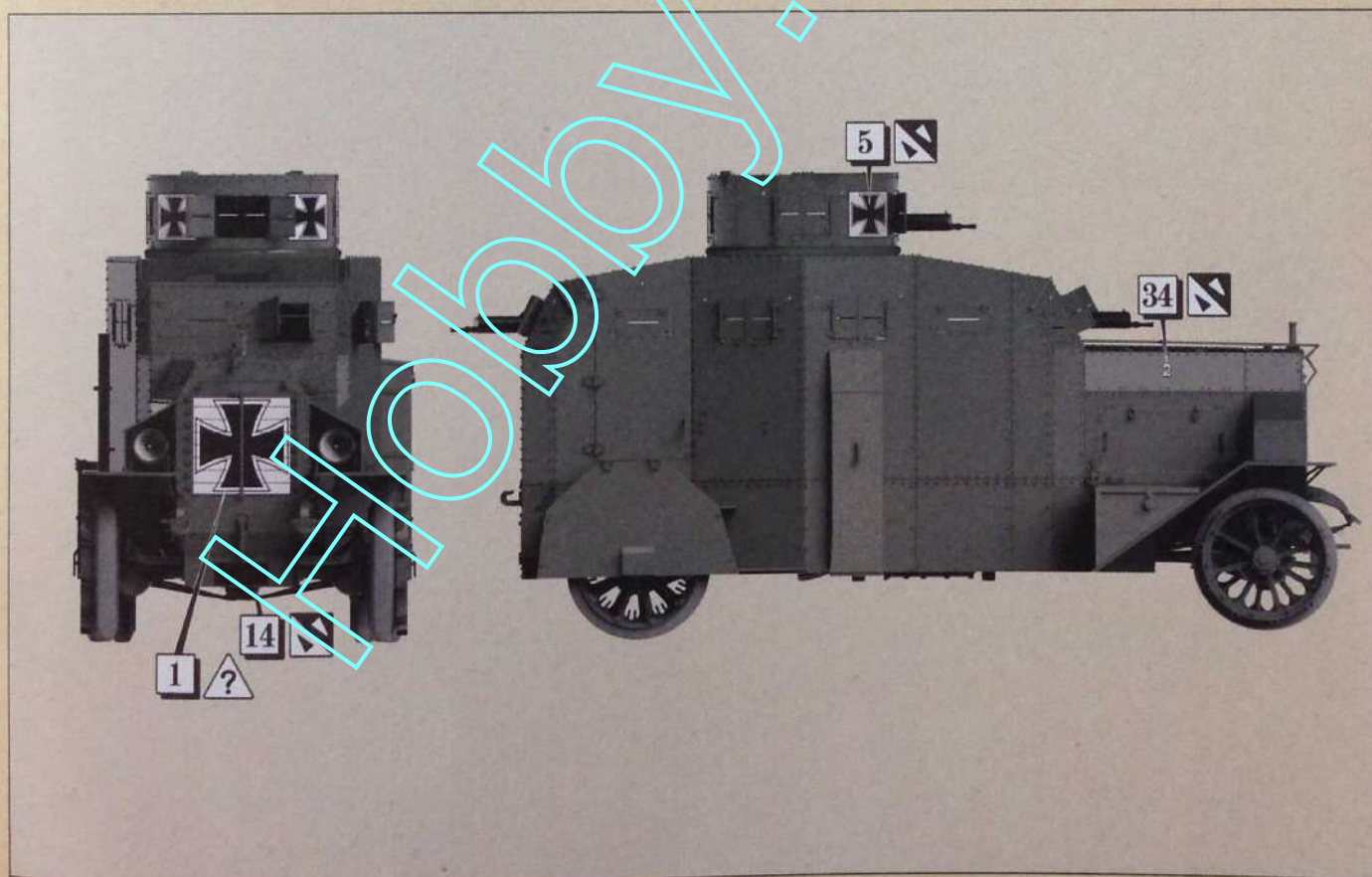

Fig. 20. Ehrhardt of the 14th brigade of government troops (was previously in the 3rd platoon). License plate B 7207 remained on car No. 2, indicating that it belonged to the Army Department "B" of the former German army. Baden, May 1920