

# 1/48 Armstrong-Whitworth F.K.8

Instruction for Standard Version K1029, K1030, K1031



The Armstrong Whitworth F.K.8 was a British WW1 two seater reconnaissance and bomber aircraft used by the Royal Flying Corps.

It was sturdy and dependable, designed by Dutch designer Frederick Koolhoven and intended as a replacement for the Royal Aircraft Factory's BE.2c and Armstrong Whitworth's earlier F.K. 3.

Around 1700 F.K.8 aircraft were produced, and it served on the Western Front and other theatres where it was useful for reconnaissance, artillery spotting, ground attack and also bombing duties.

Despite its popularity with the men who flew it, the F.K.8 was unfairly overshadowed by the better known R.E.8 and today is one of the lesser known British two seaters of WW1.

Known affectionately to airmen as the "Big Ack", the F.K. 8 type first flew in 1916 and was developed in various stages. It was powered by a 120 hp Beardmore engine and featured a box-like oleo with skid shock absorber undercarriage and two A-shaped radiators straddling both sides of the fuselage and meeting as an inverted V near the top wing.

The F.K.8's standard armament featured a Lewis gun on a Scarff ring for the observer and a fixed forward firing .303 Vickers machine gun for the pilot. The first F.K. 8's went to France in January 1917 equipping 35 Squadron RFC. It served with five squadrons on the Western Front and also saw service in the Middle East as well as Home Defence duties in Britain. The last squadron to use the F.K.8 was 150 Squadron which was disbanded in 1919. Two Victoria Crosses were won by F.K. 8 pilots.

At the war's end eight F.K.8 aircraft were registered for civil use, with two of them used in Australia as part of the early fleet of the Queensland and Northern Territory Aerial Services which later became the airline Qantas.

CSM SIA  
Lubanas 78, LV-1073,  
Riga, Latvia



Visit our website  
[www.copperstatemodels.com](http://www.copperstatemodels.com)

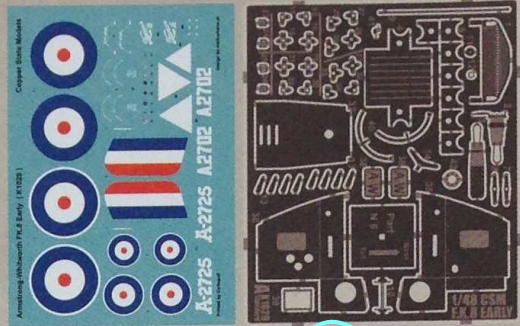
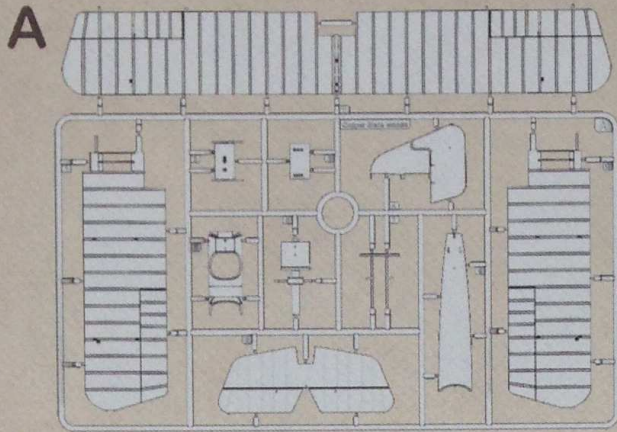

Decals and PE for F.K.6 Early/K1029

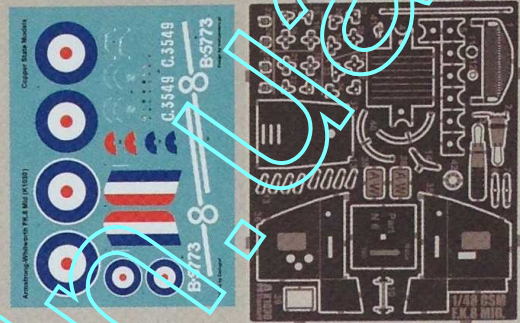
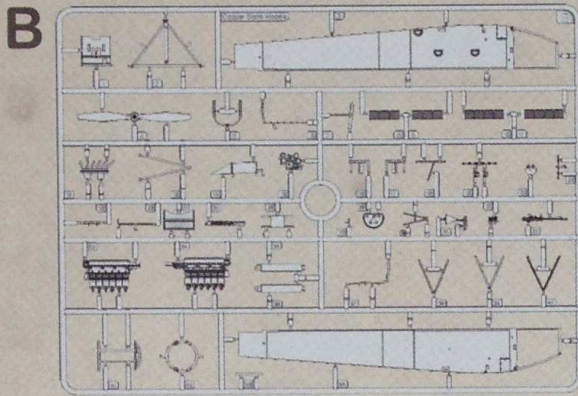

Decals and PE for F.K.8 Mid./K1030

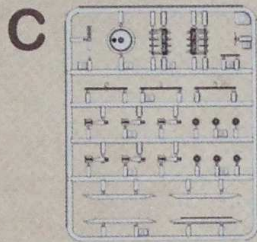

Only for F.K.8 Late/K1031

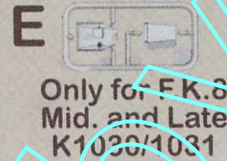

Only for F.K.8 Mid. and Late K1030/1031

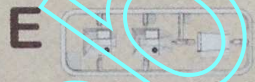

Only for F.K.8 Early/K1029

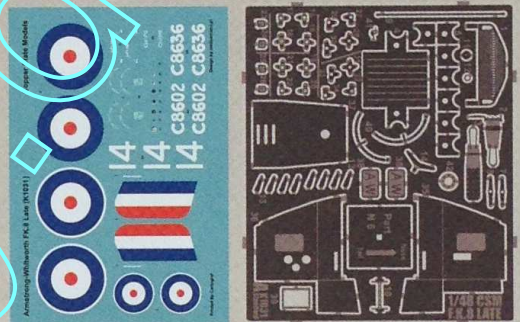

Decals and PE for F.K.8 Late/K1031

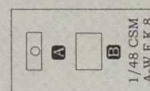

Acetate windscreens

No	Colours
1	Copper
2	Brass
3	Semi Gloss Black
4	Aluminium
5	Gun Metal
6	White
7	Light Wood
8	Leather
9	PC10
10	Clear Doped Linen
11	Battleship Grey
12	Dark wood
13	White
14	Rubber
15	Grey

### Symbols Reference

- Colour
- Use cyanoacrylate
- Other side
- Cut/Remove
- Subassembly
- Drill
- No Glue
- Bend
- Apply Decal
- Attention
- Option
- Marking options

Photo Etch Part

# Cockpit

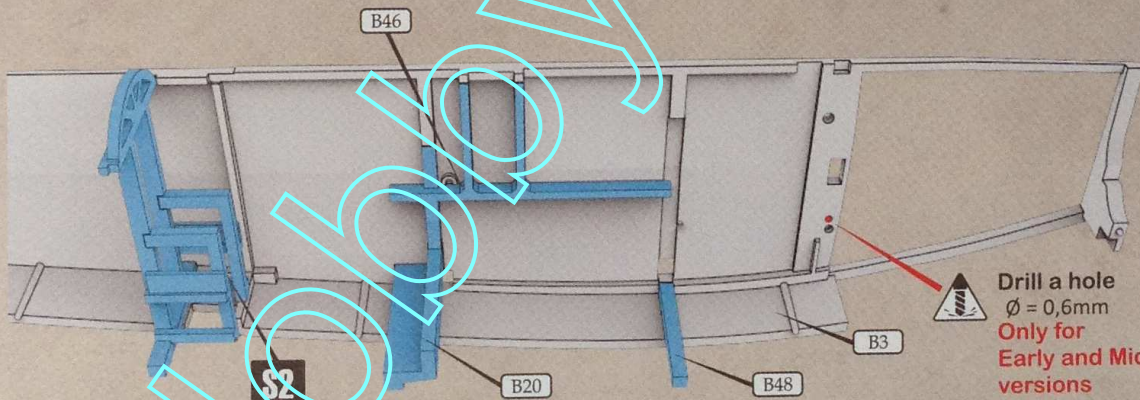
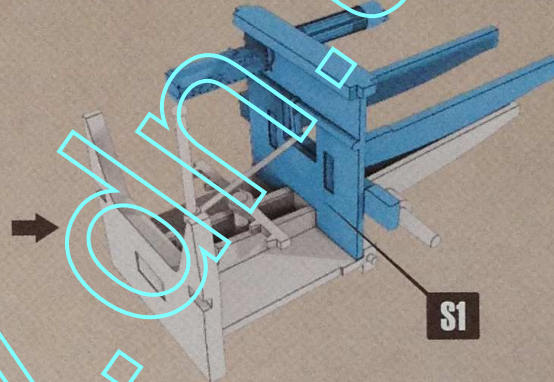
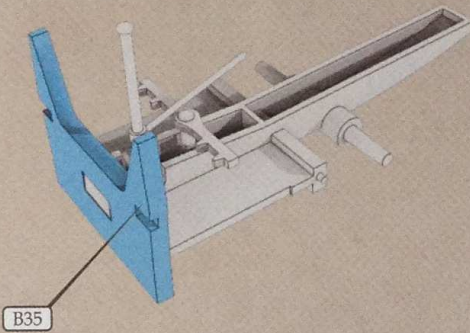
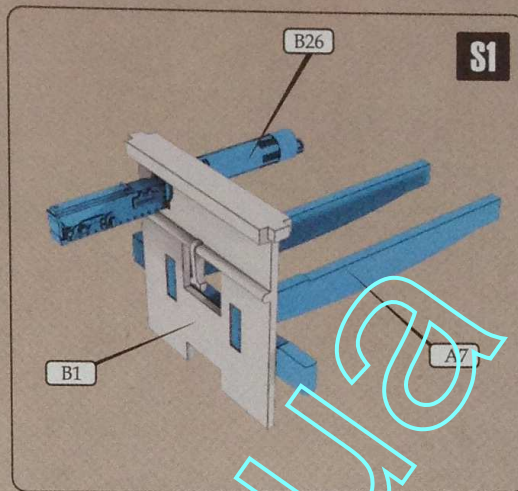
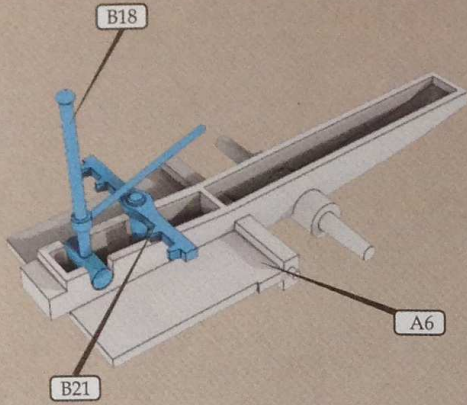

Drill a hole  
 $\varnothing = 0,6\text{mm}$   
Only for  
Early and Mid.  
versions

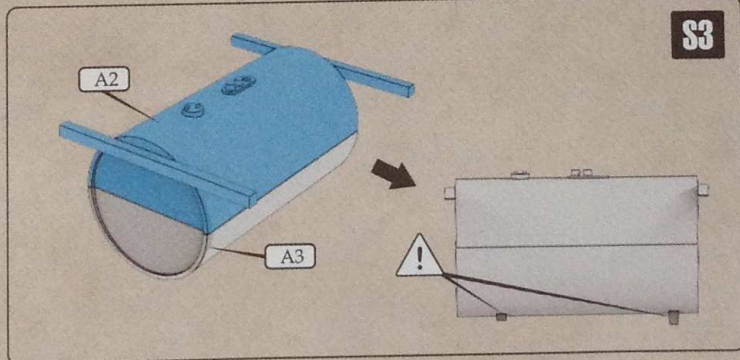
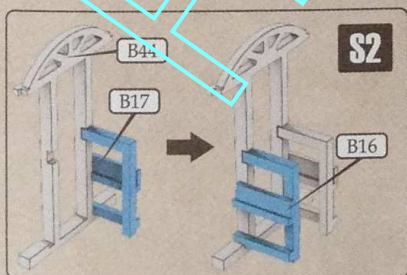

# Fuselage and cockpit

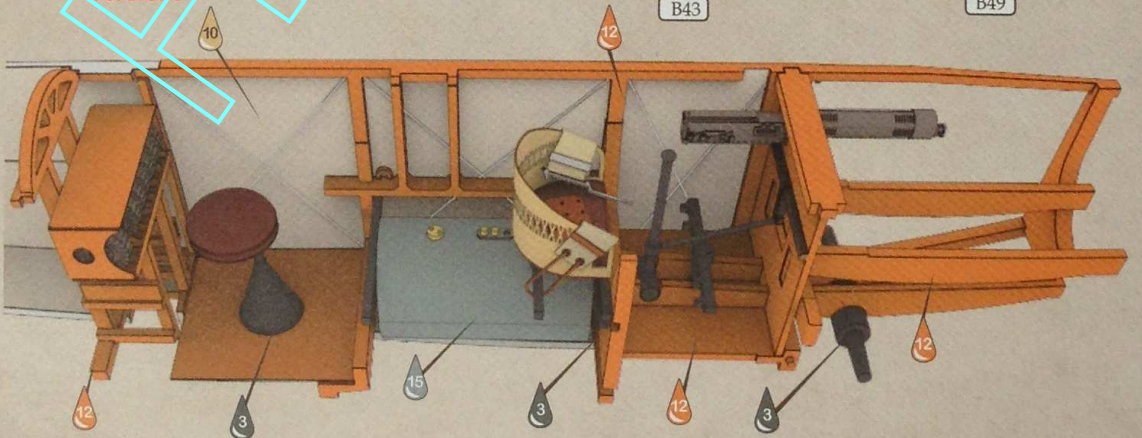
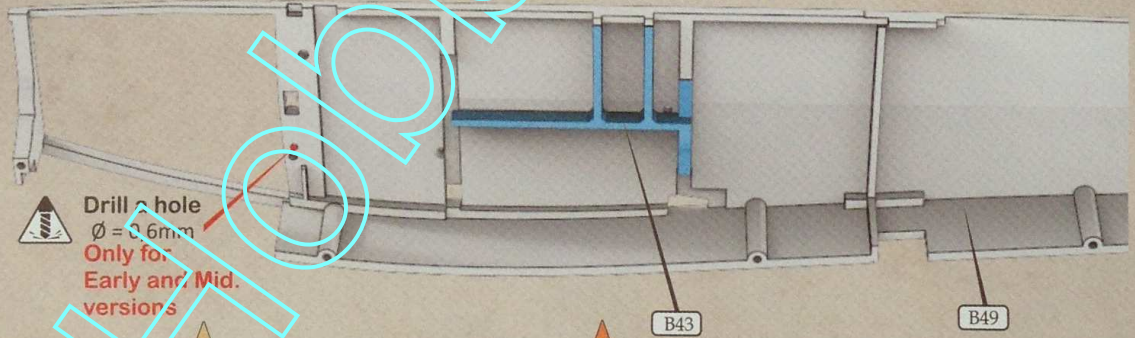
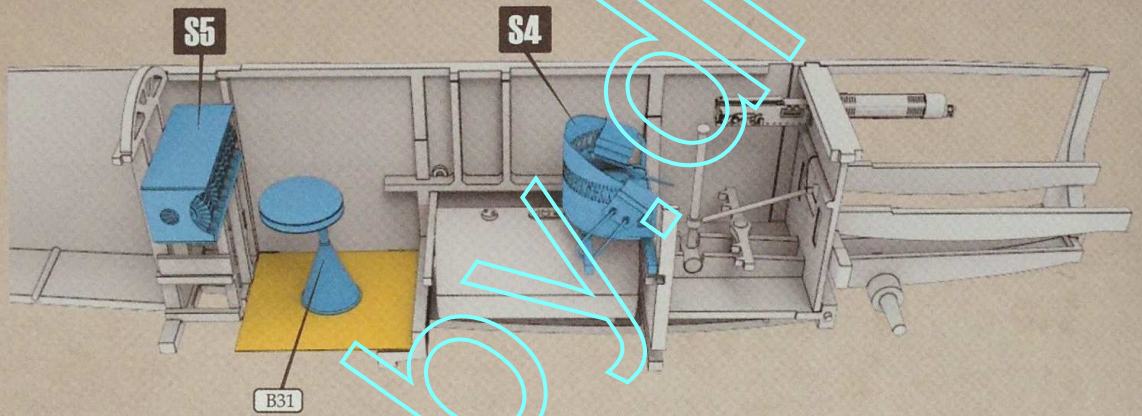
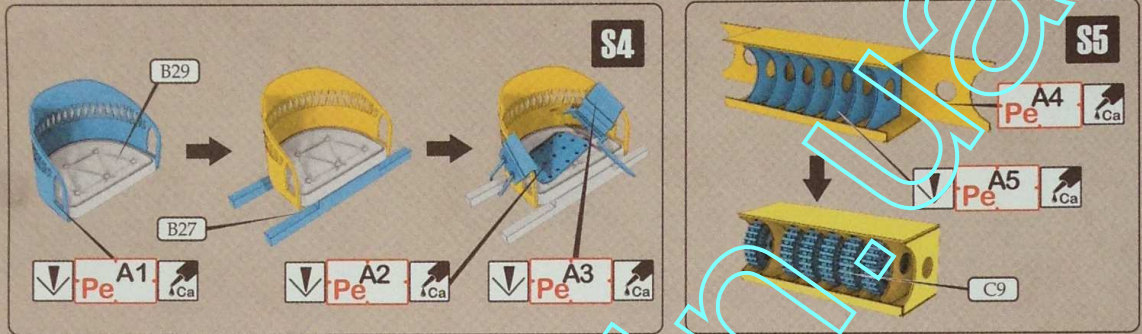
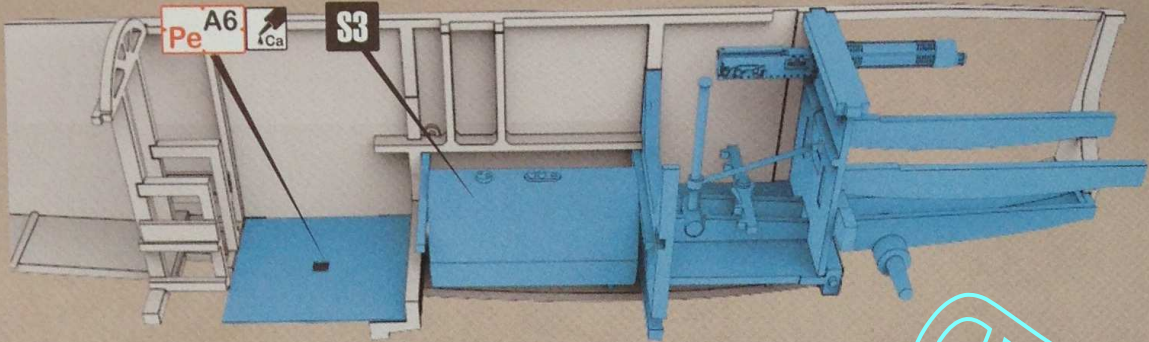

# Fuselage and cockpit

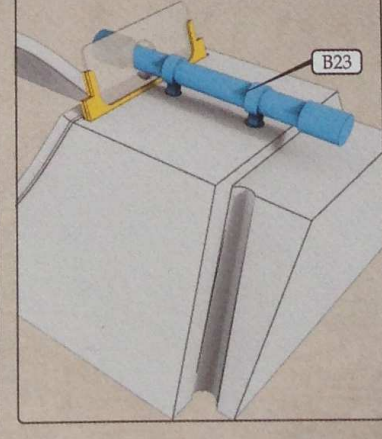
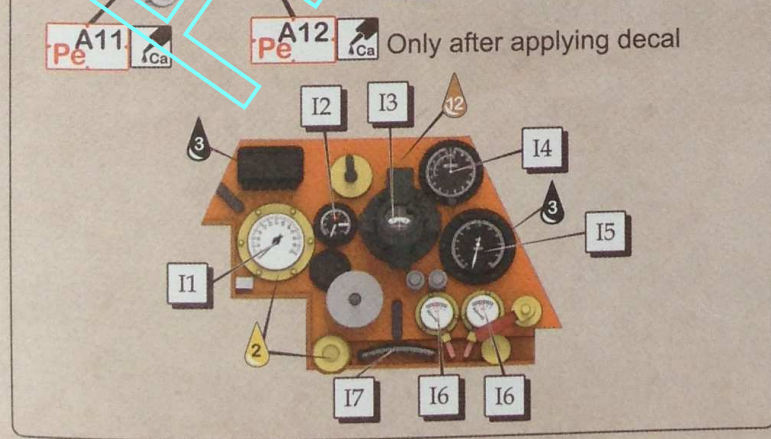
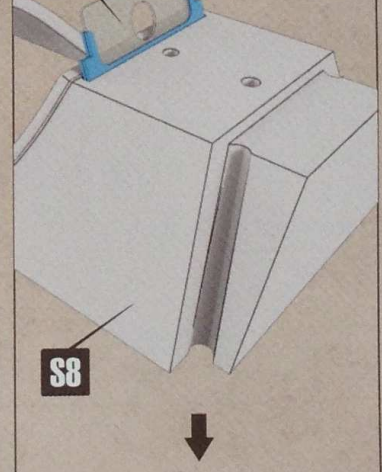
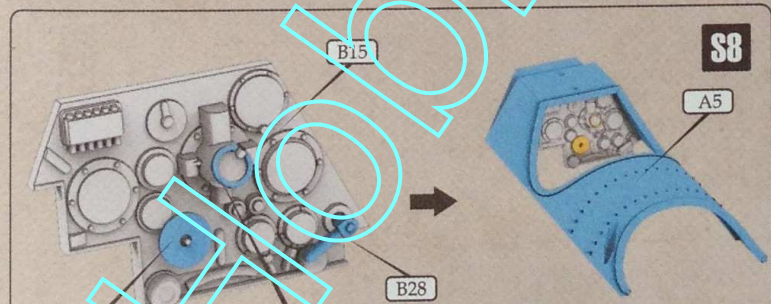
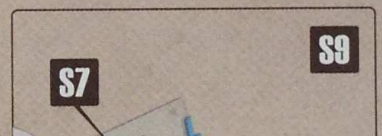
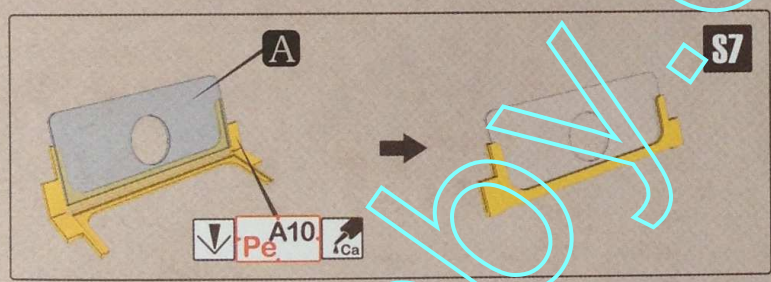
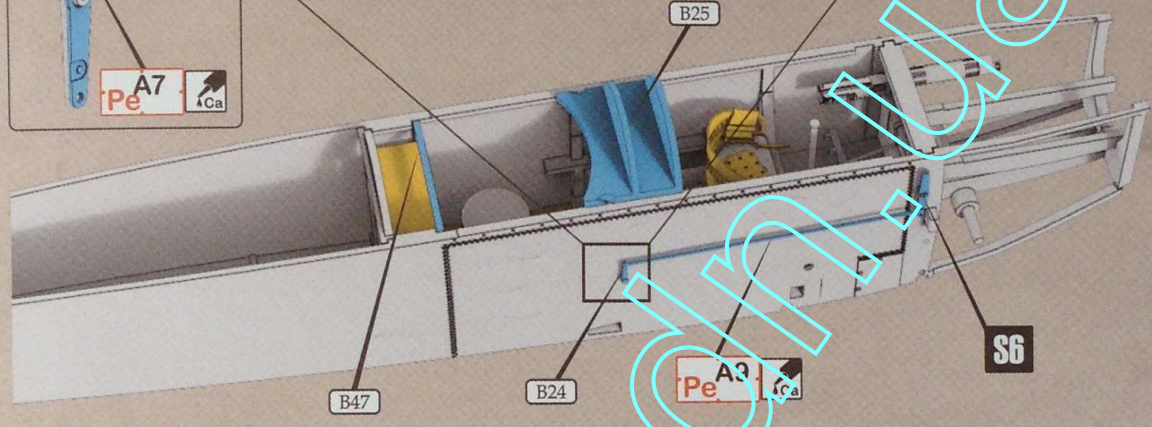
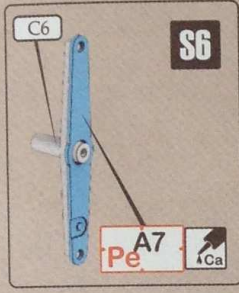
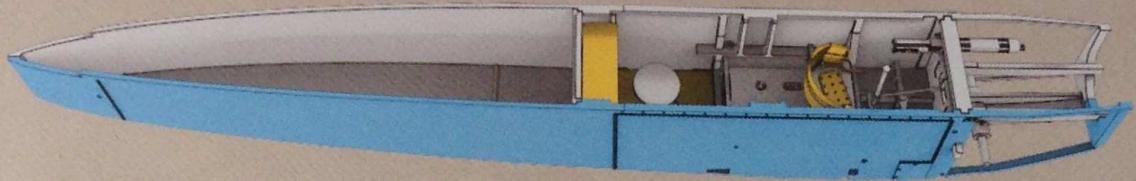

# Fuselage

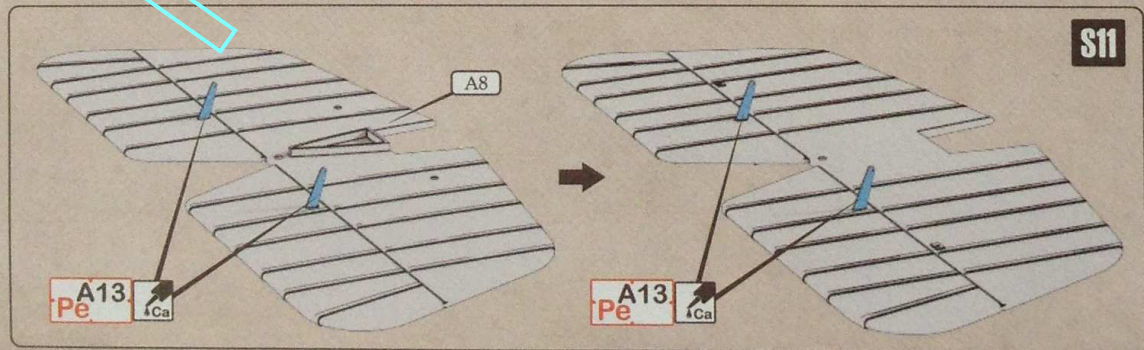
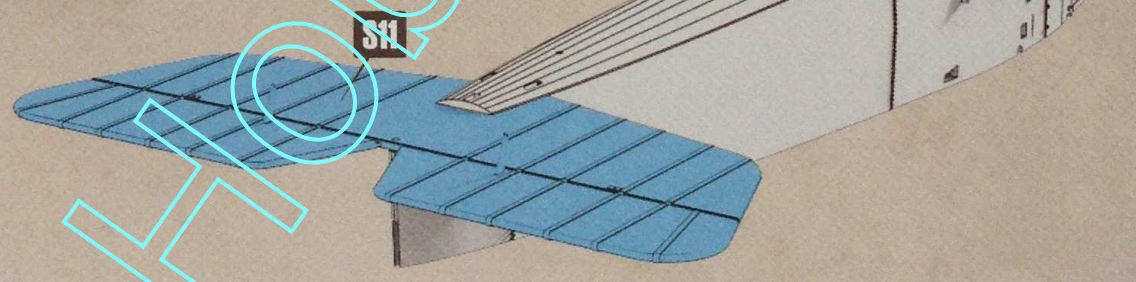
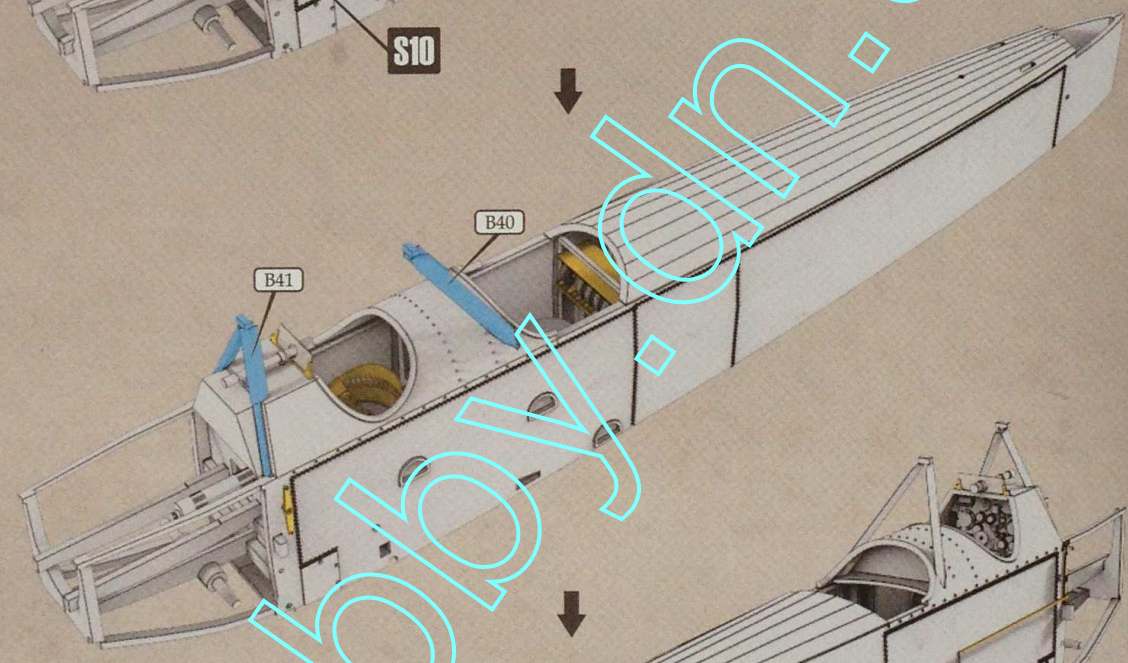
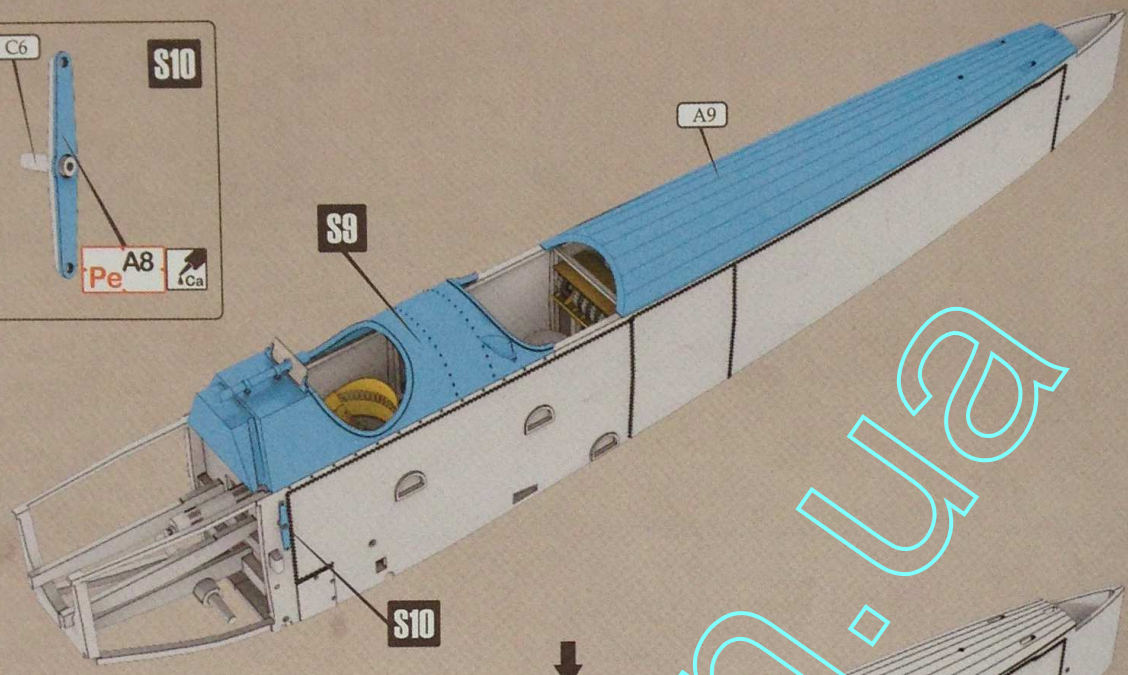
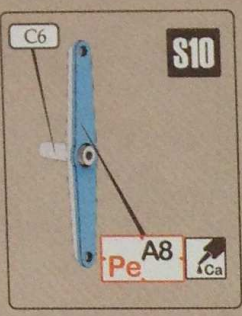

# IV Lower wing and rudder

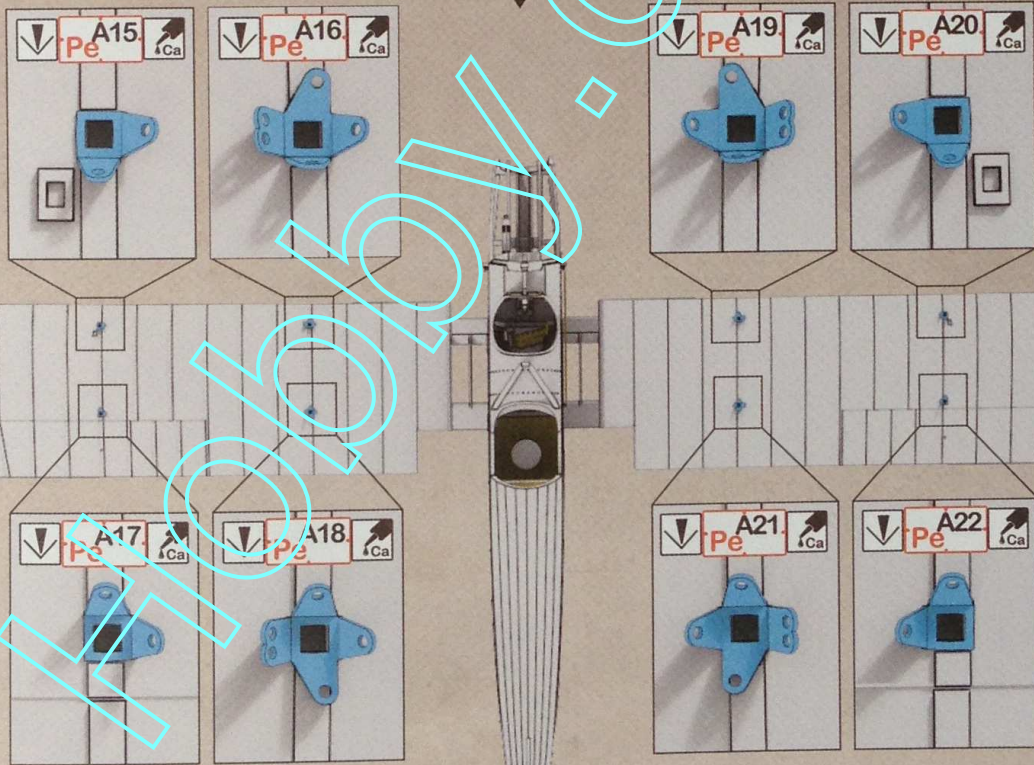
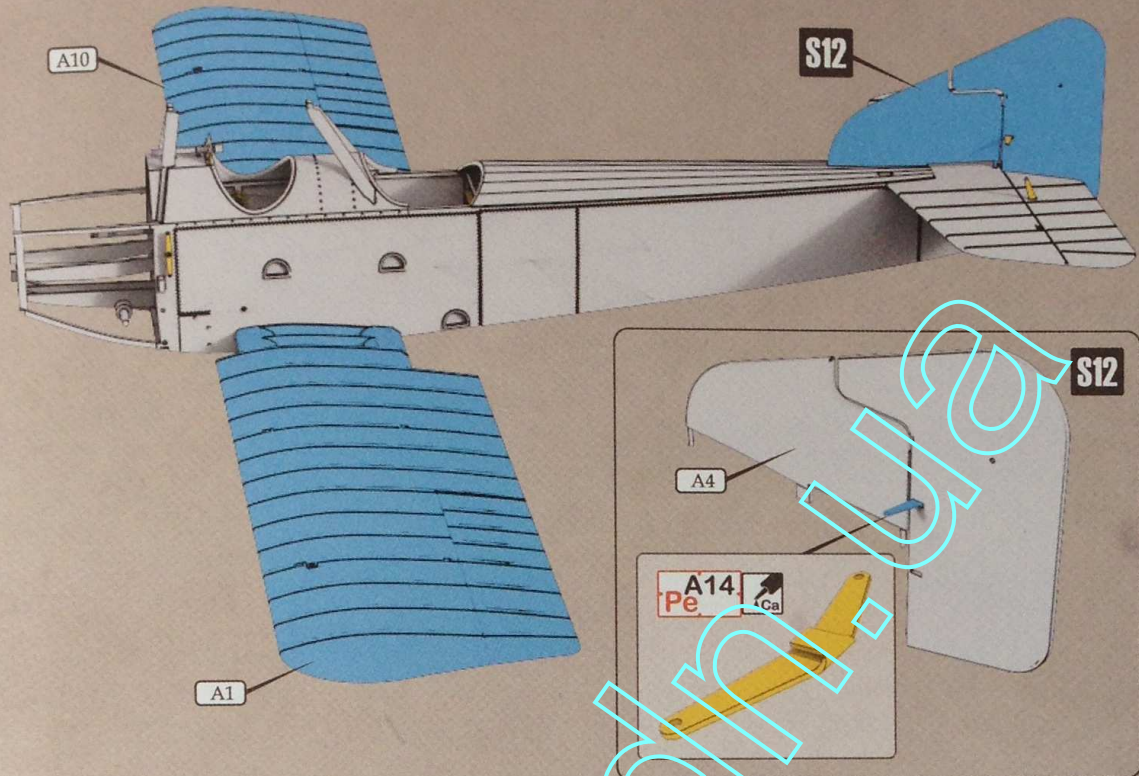

Lower wing aileron horn

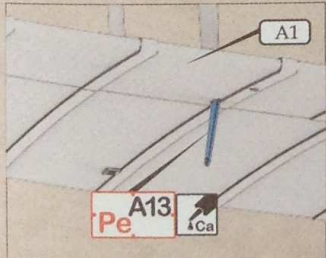

Lower wing aileron horn

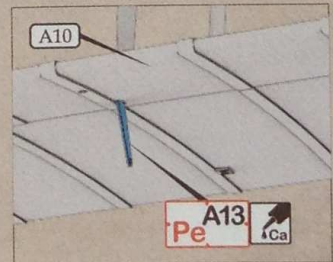

# V Struts and top wing

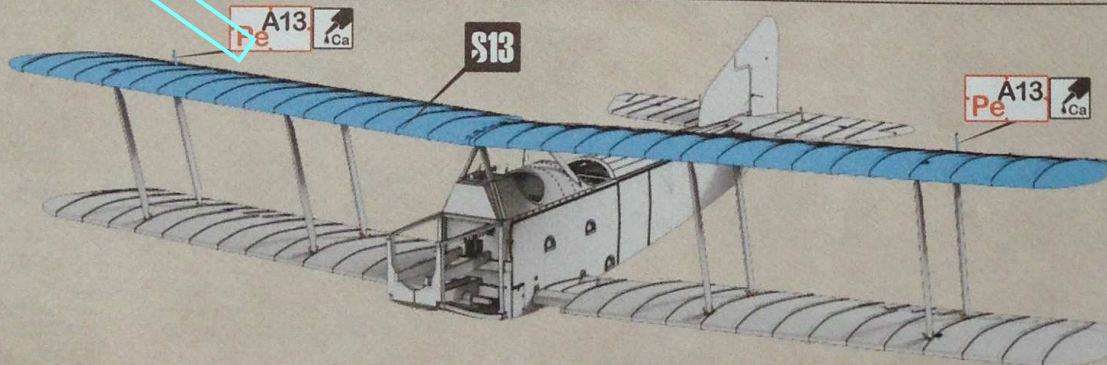
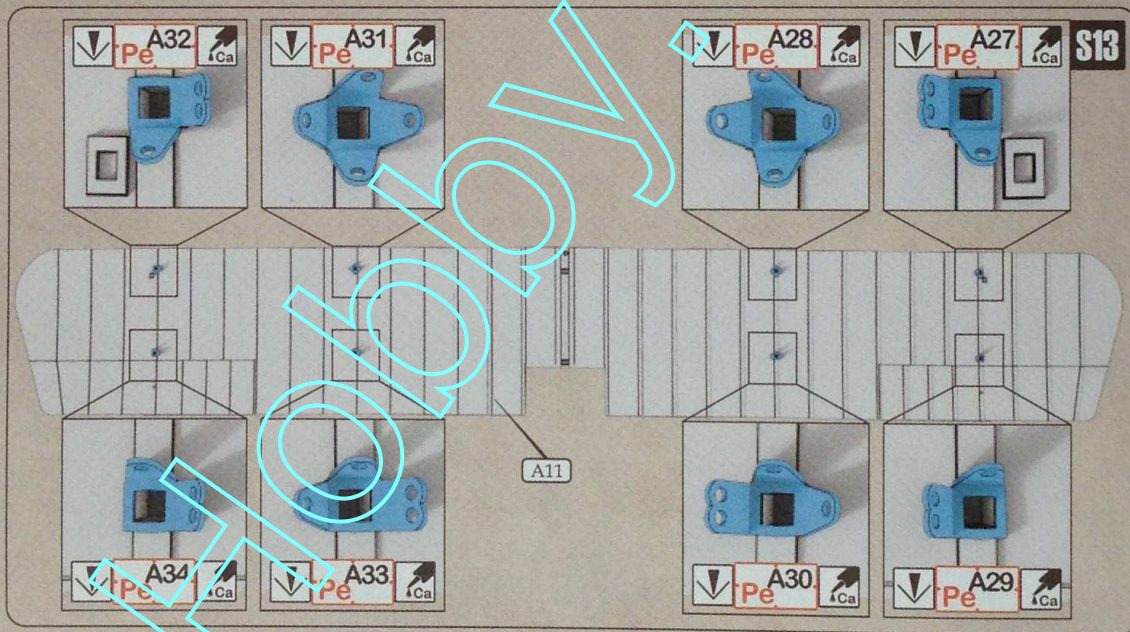
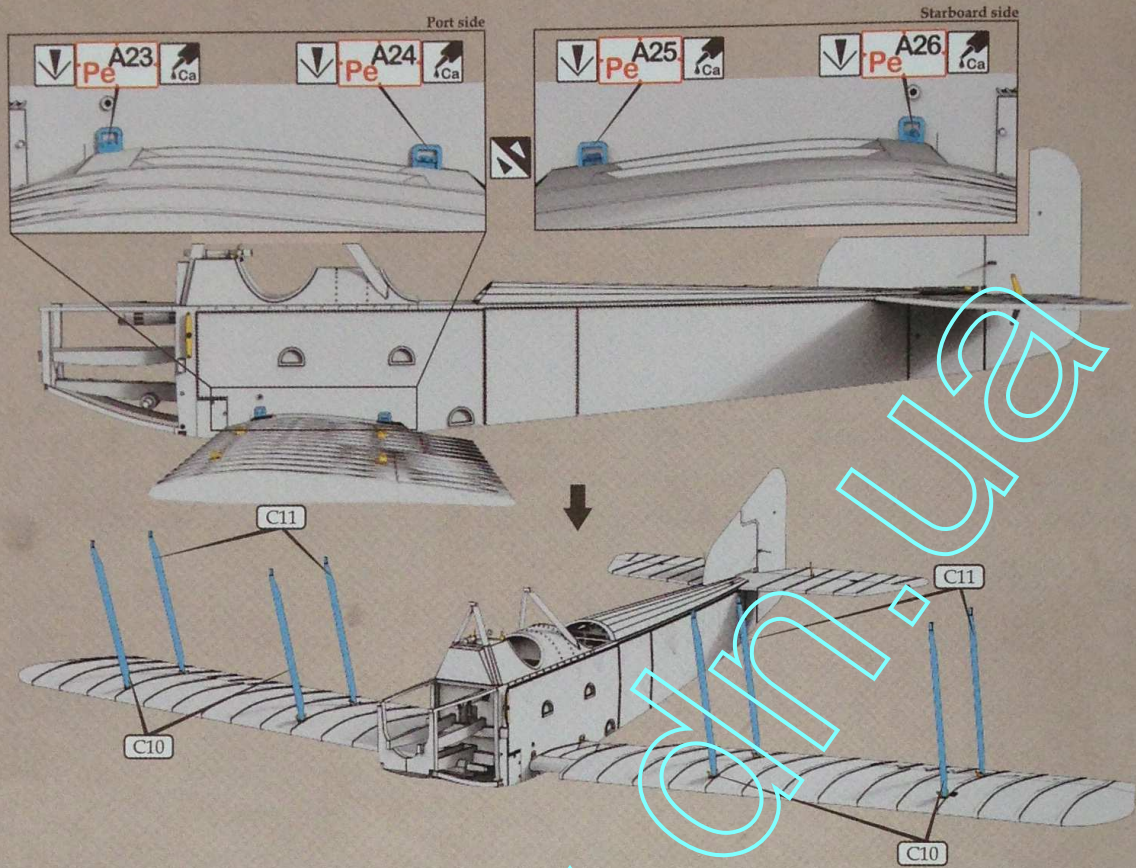



# VI Engine

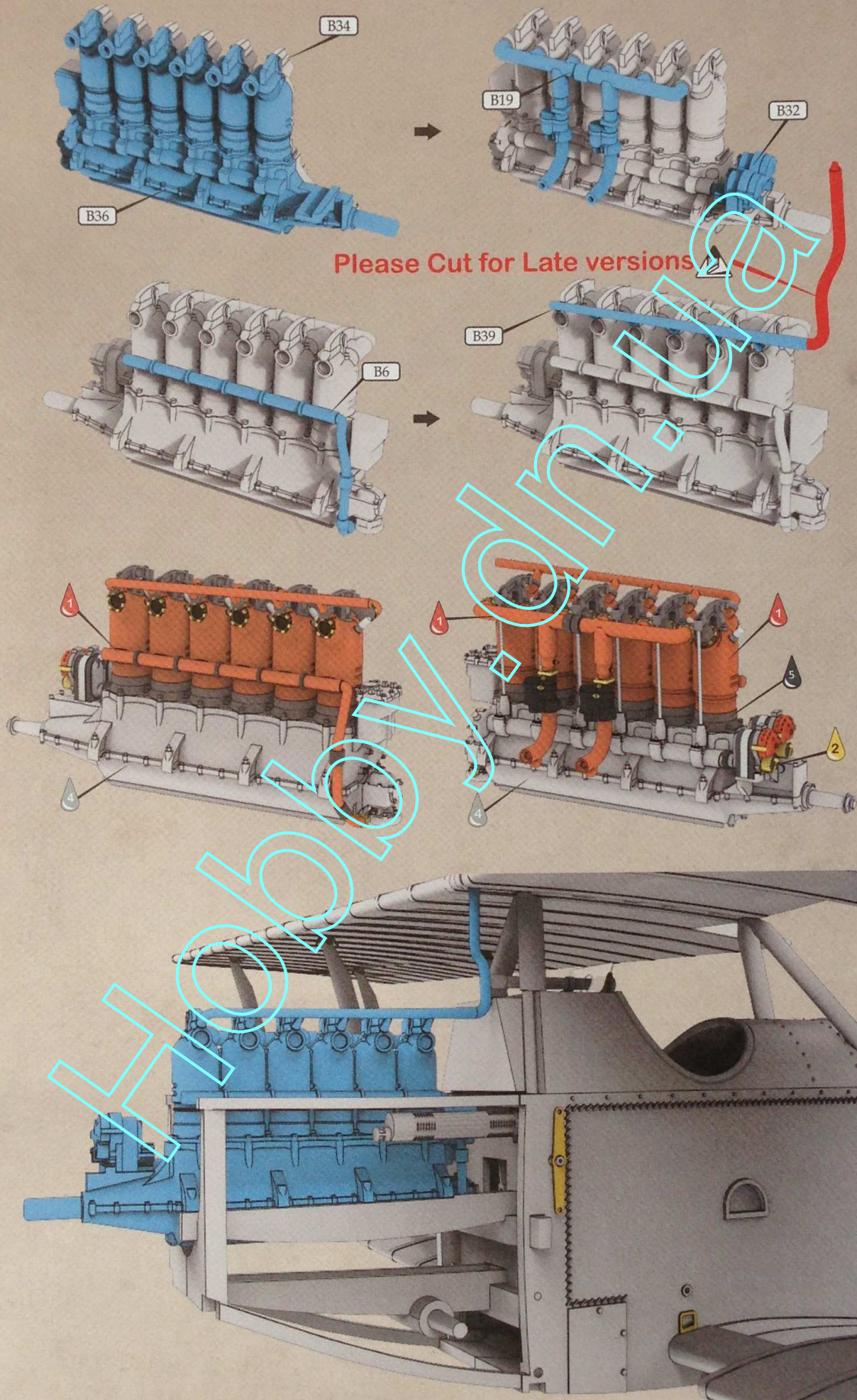

# VII Early, Mid. version subassembly

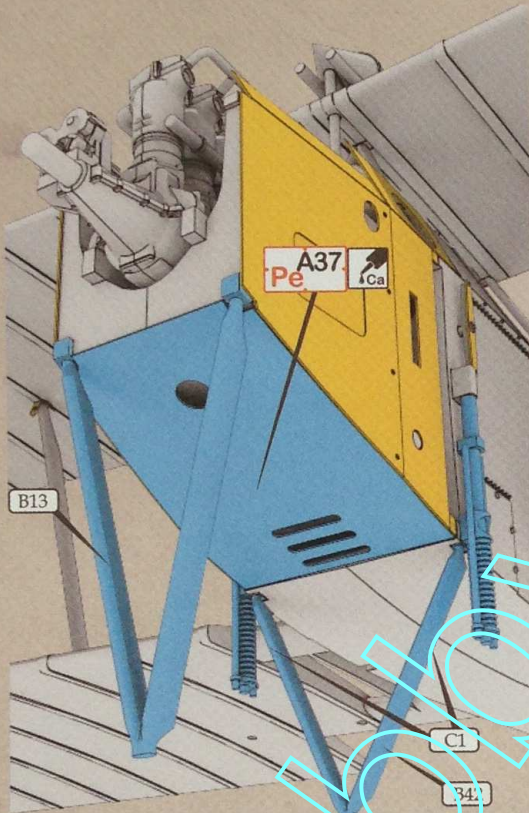
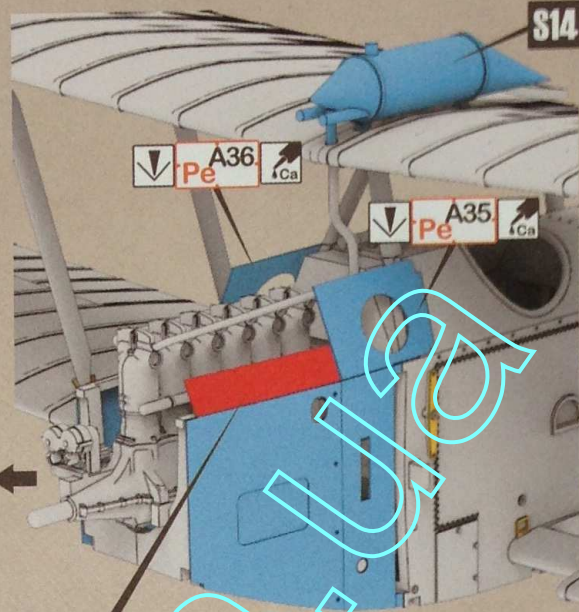
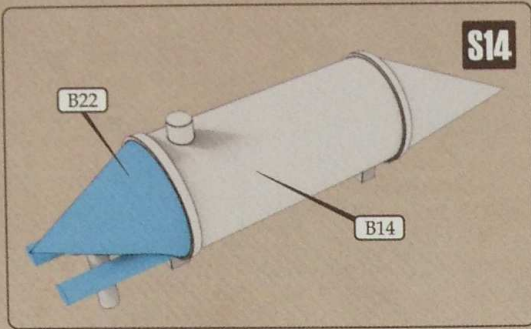

Cut for Early version, marking B

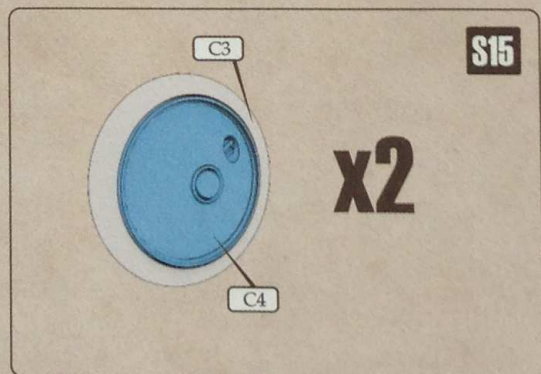
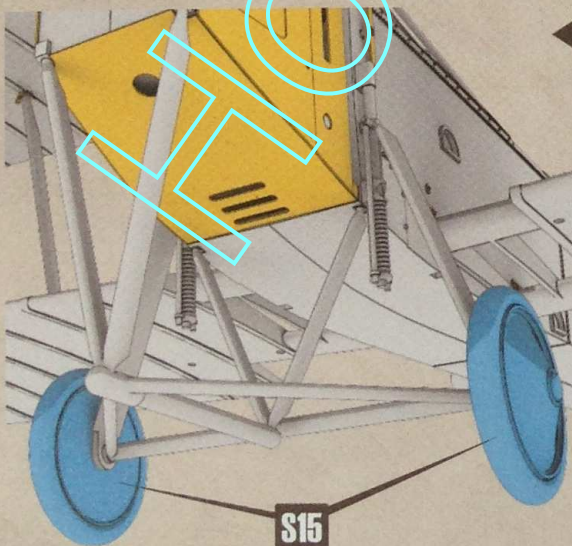
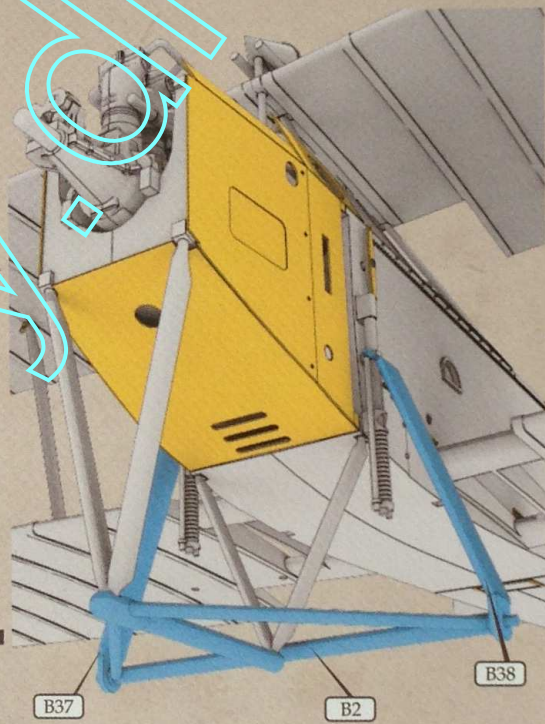

# VII Late version subassembly

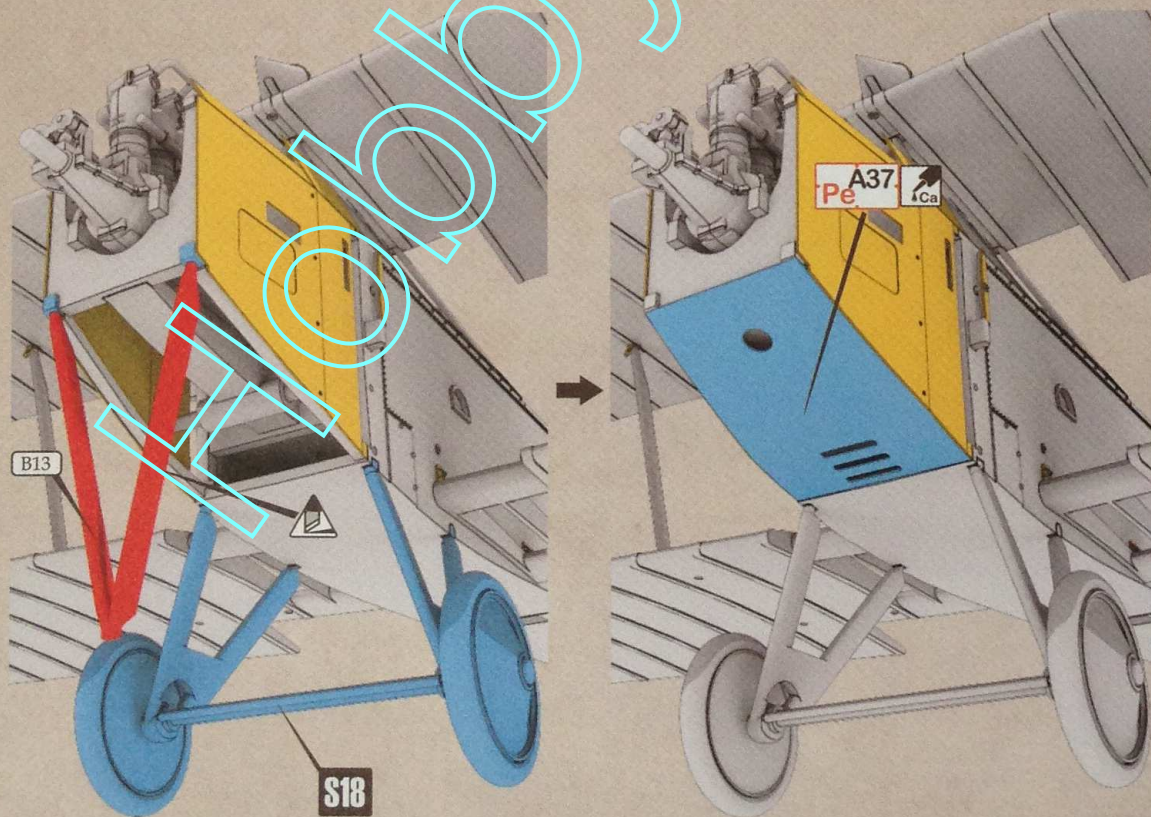
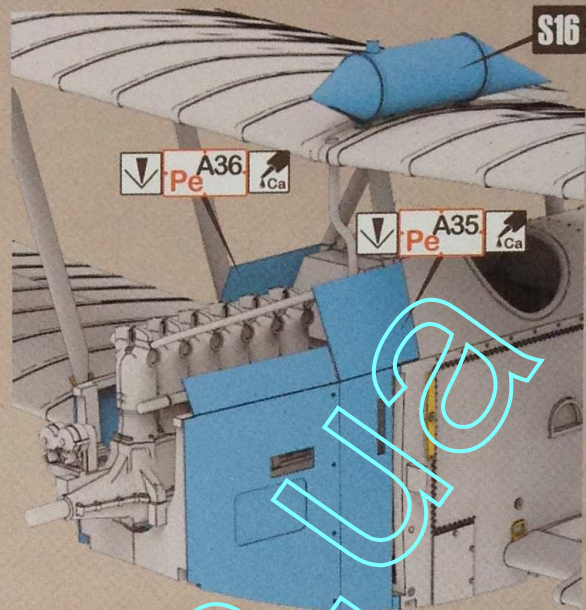
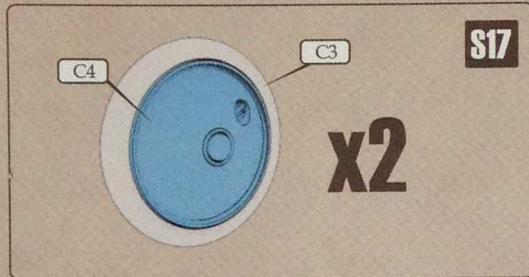
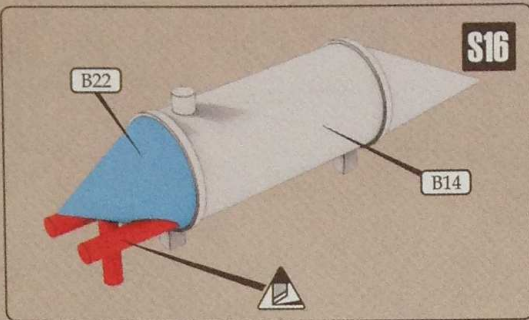

# VIII Radiators and cowlings

F.K.8 Early Version  
k1029

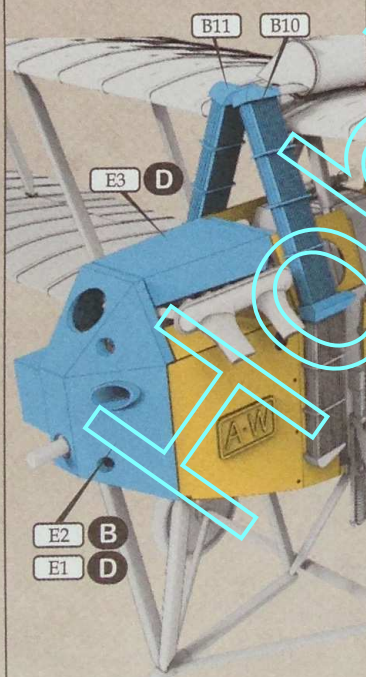
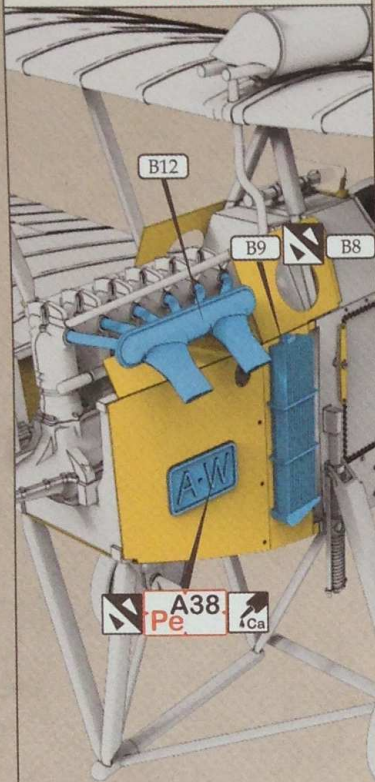

F.K.8 Mid. Version  
k1030

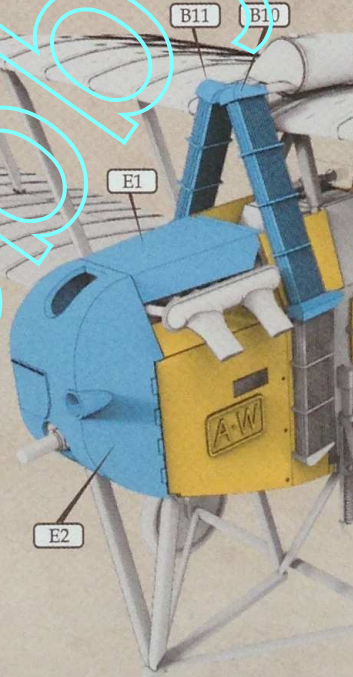
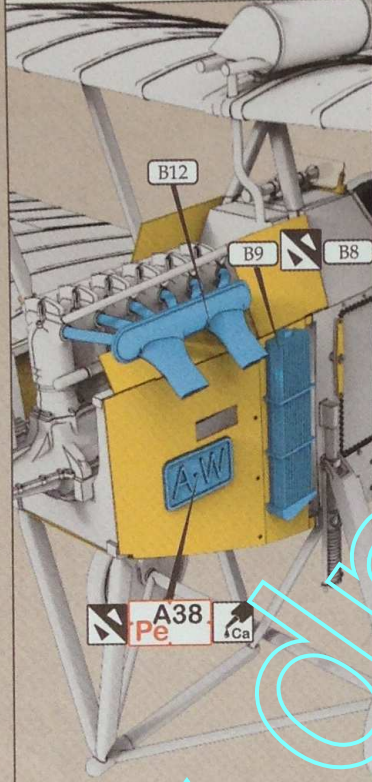

F.K.8 Late Version  
k1031

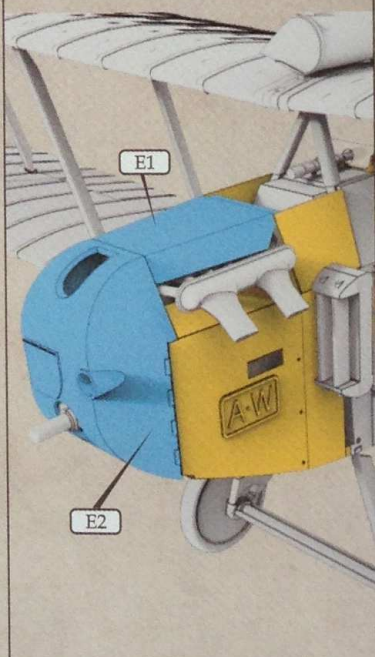
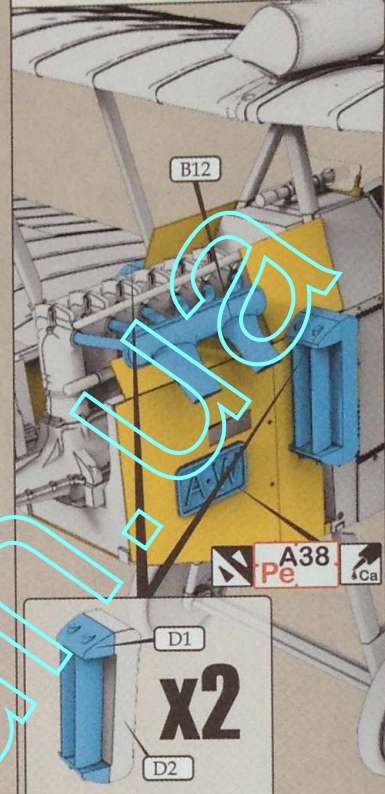

# IX Lewis MG and tail skid

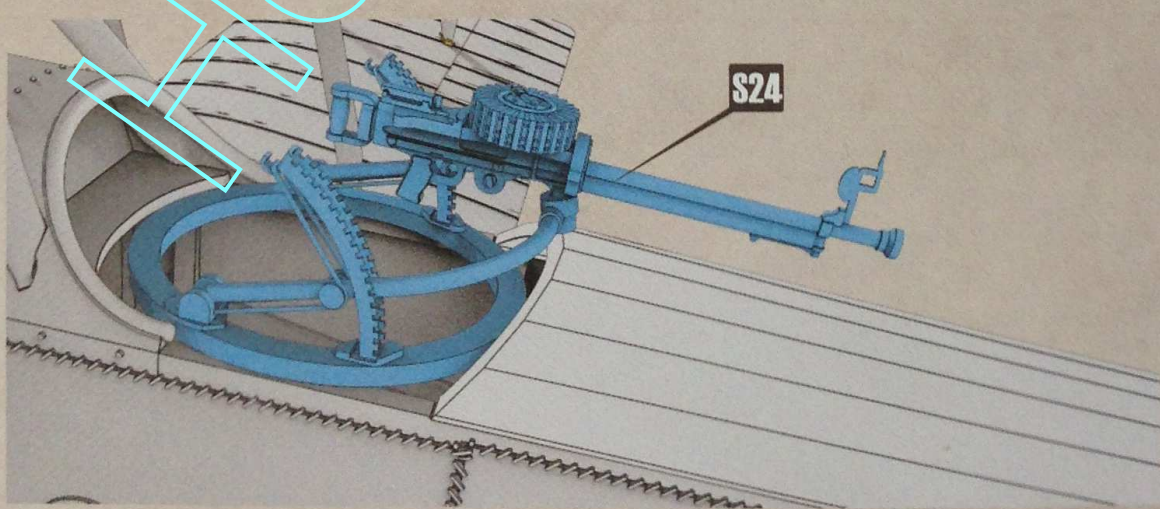
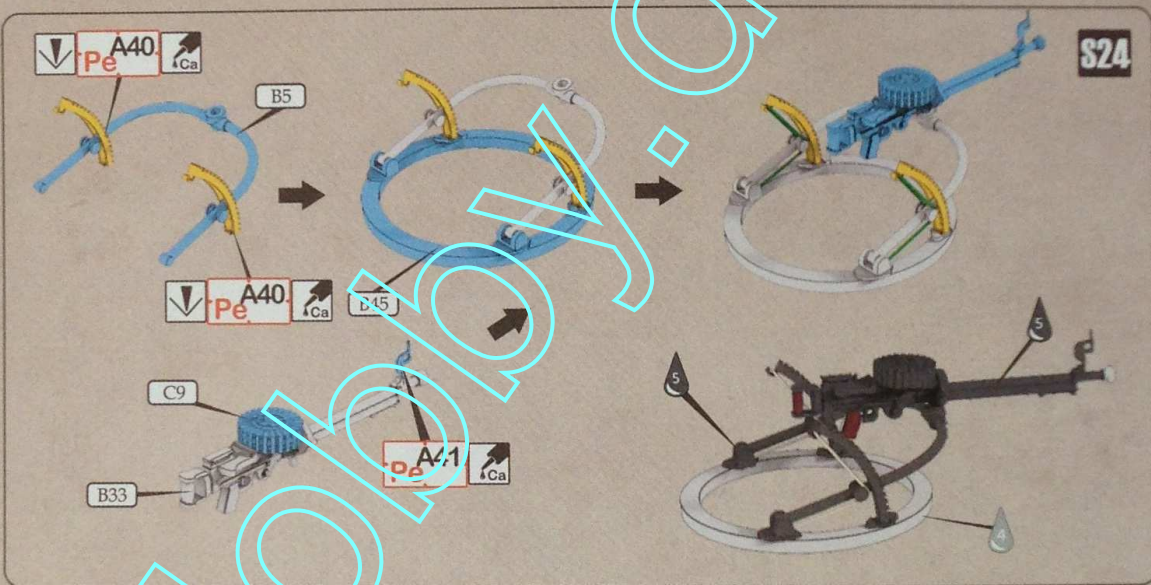
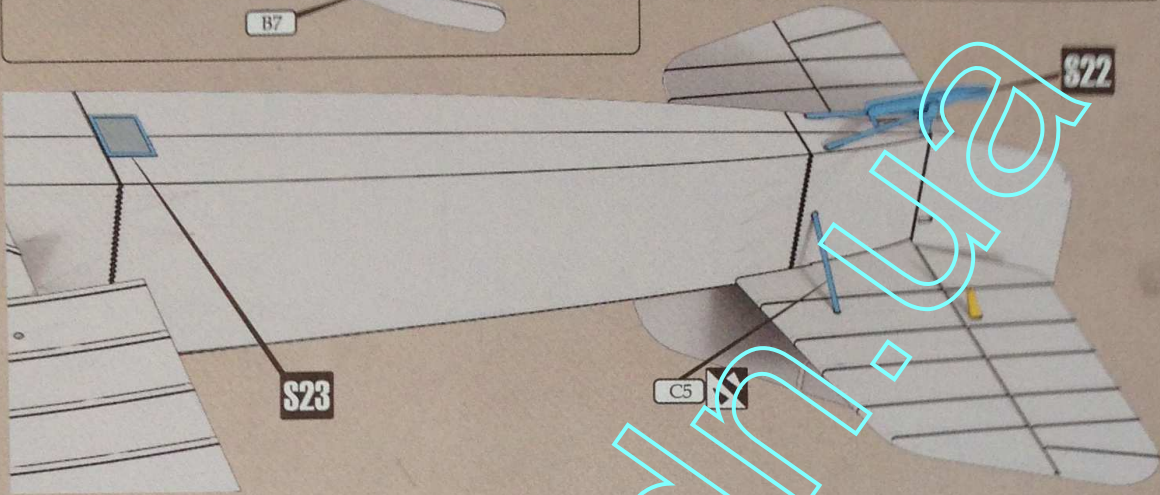
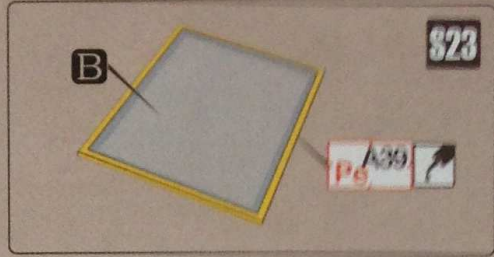
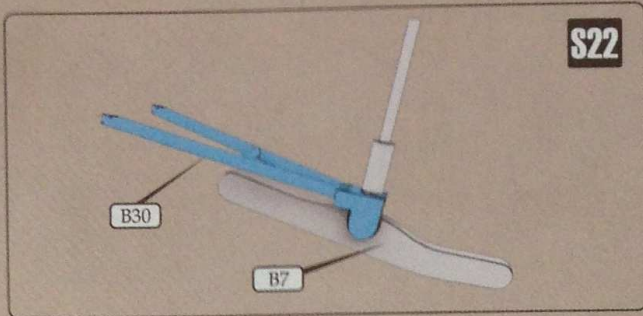

# X Bombs and propeller

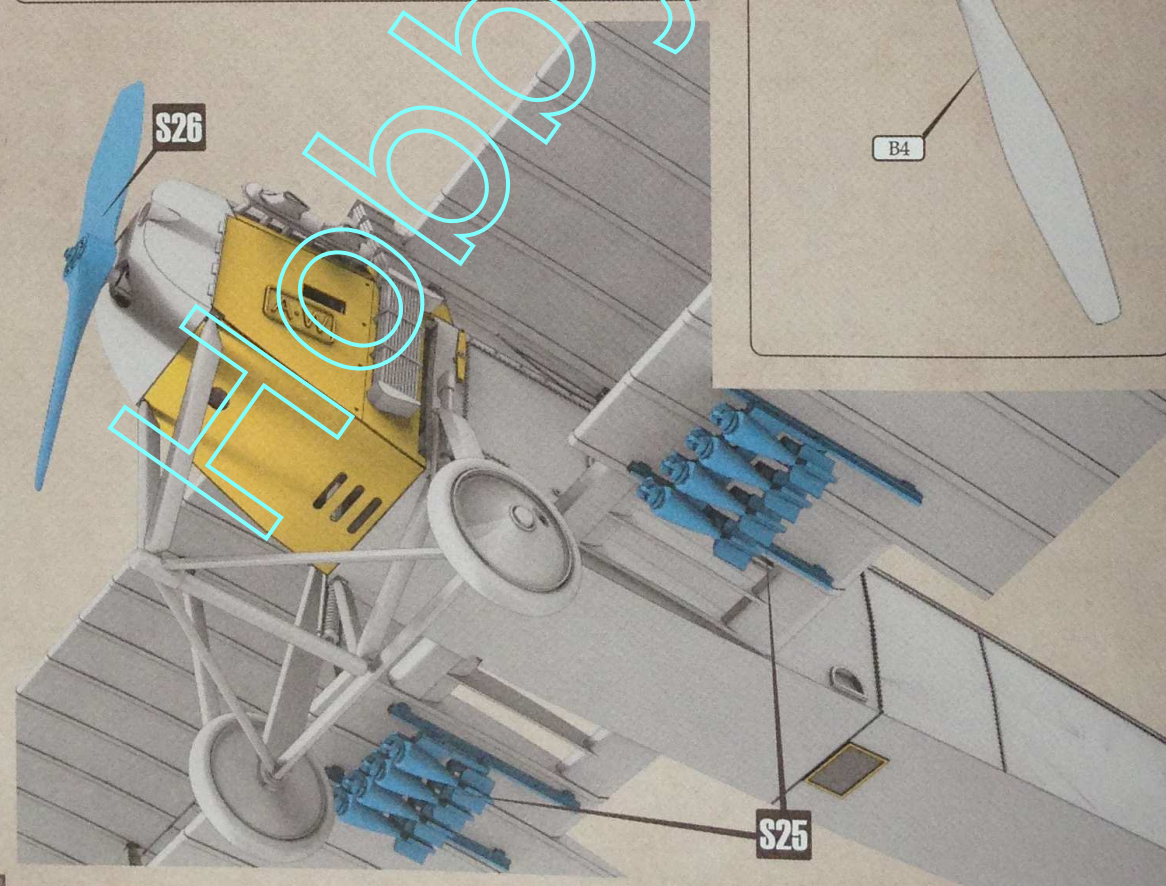
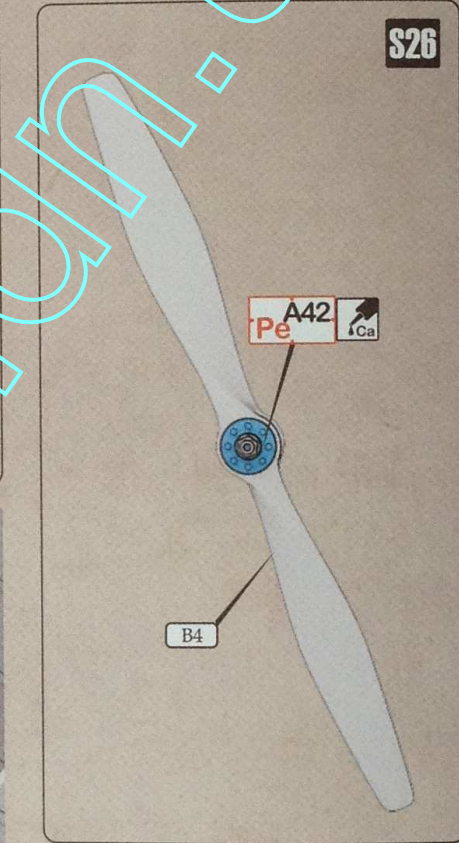
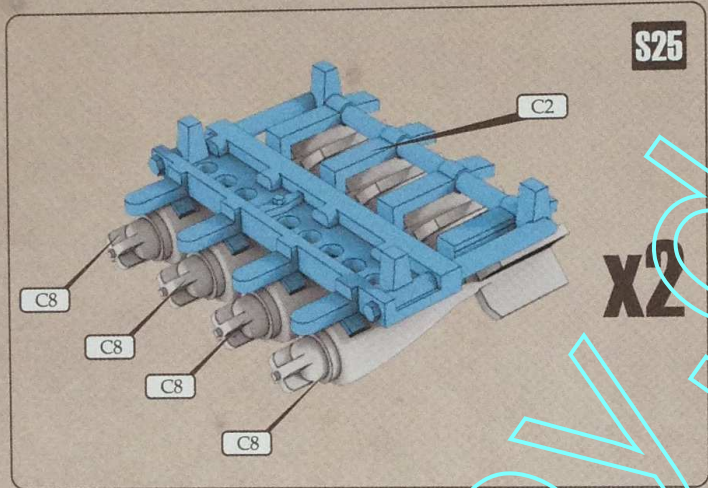
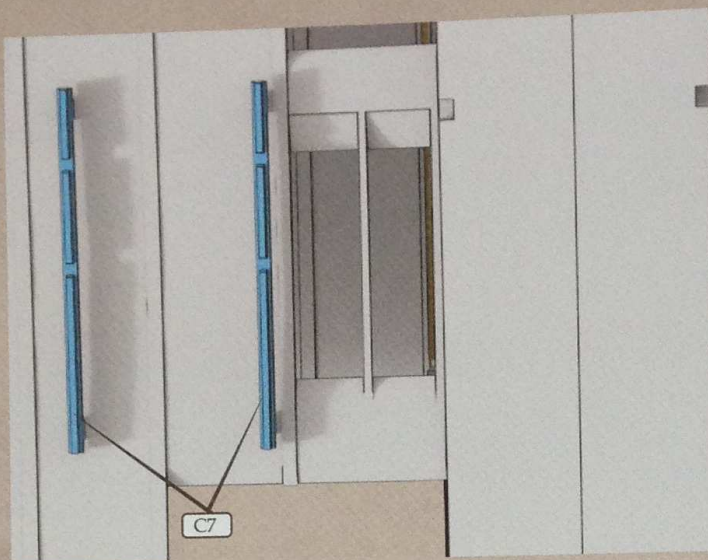

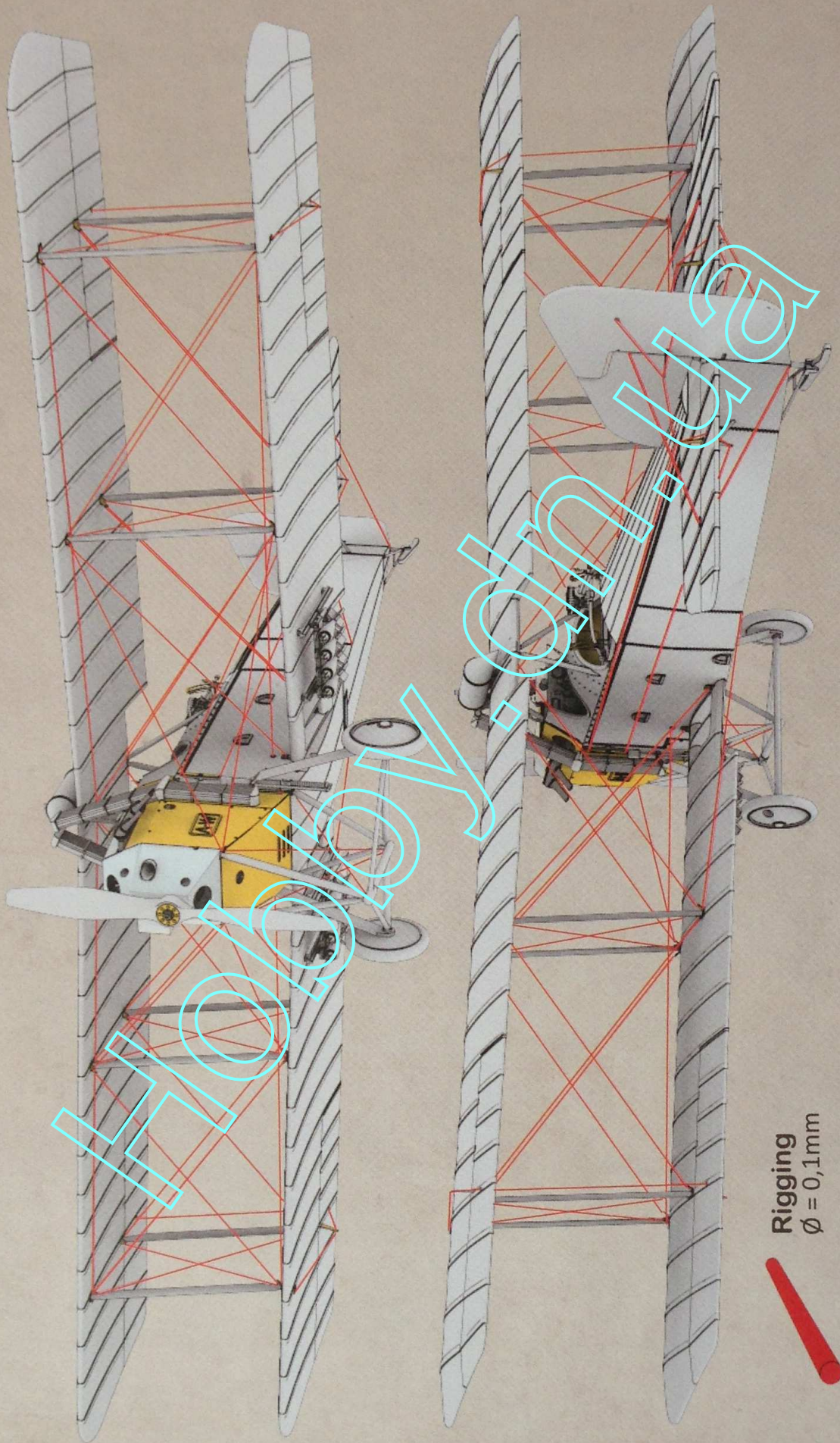

# XII Paint colours and markings

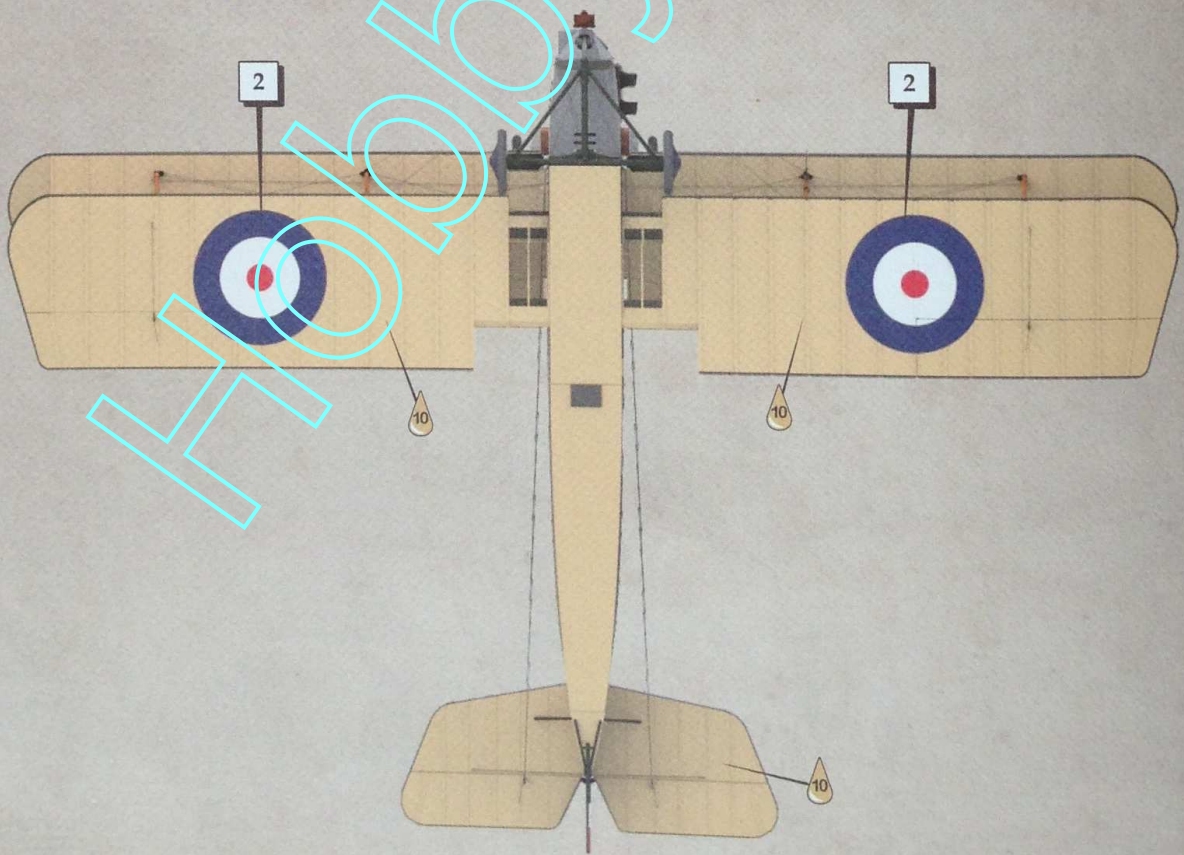
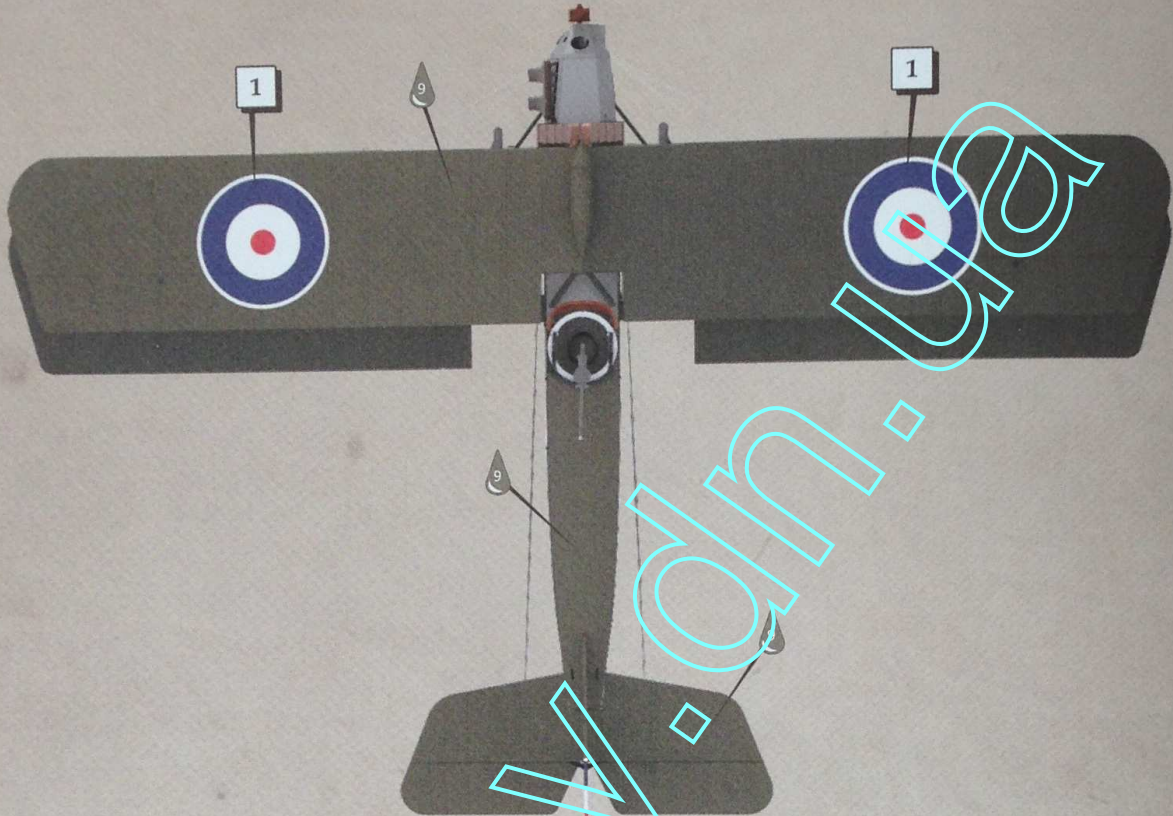
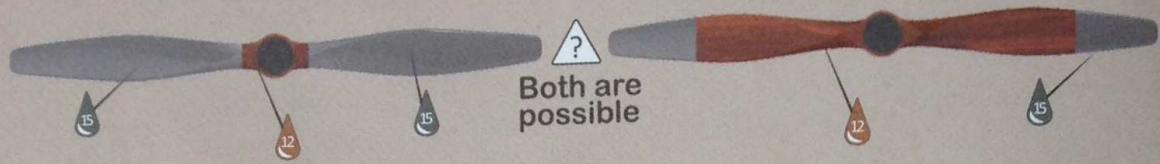



# XII Colours and markings Early version

**B** Armstrong Whitworth F.K.8 A.2702 No.2 Sqn RFC, Summer 1917

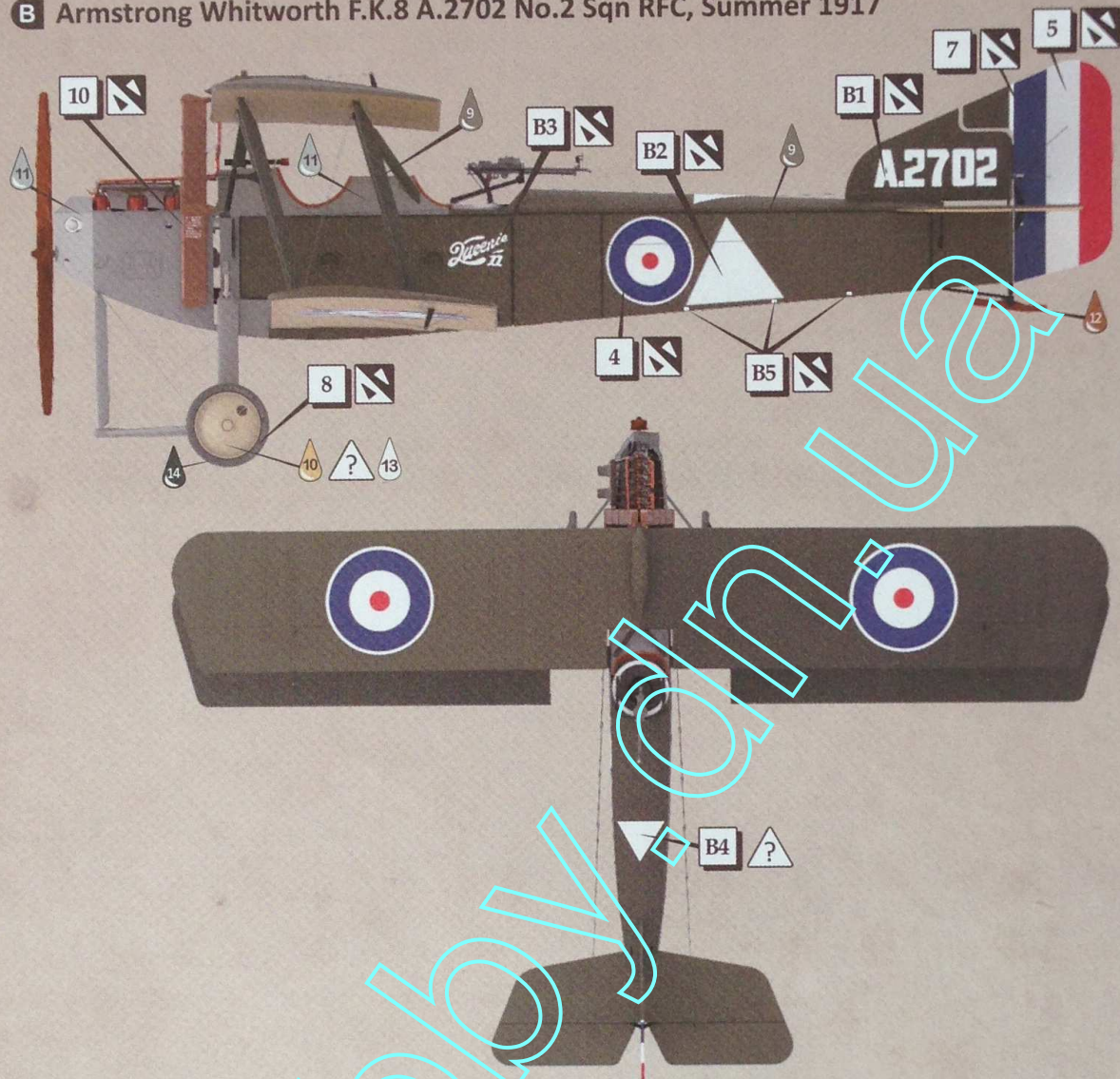

**D** Armstrong Whitworth F.K.8 A2725, Newcastle, February 1917, before going to Aircraft Repair Depot at Farnborough for tests with a 140-hp RAF 4a engine

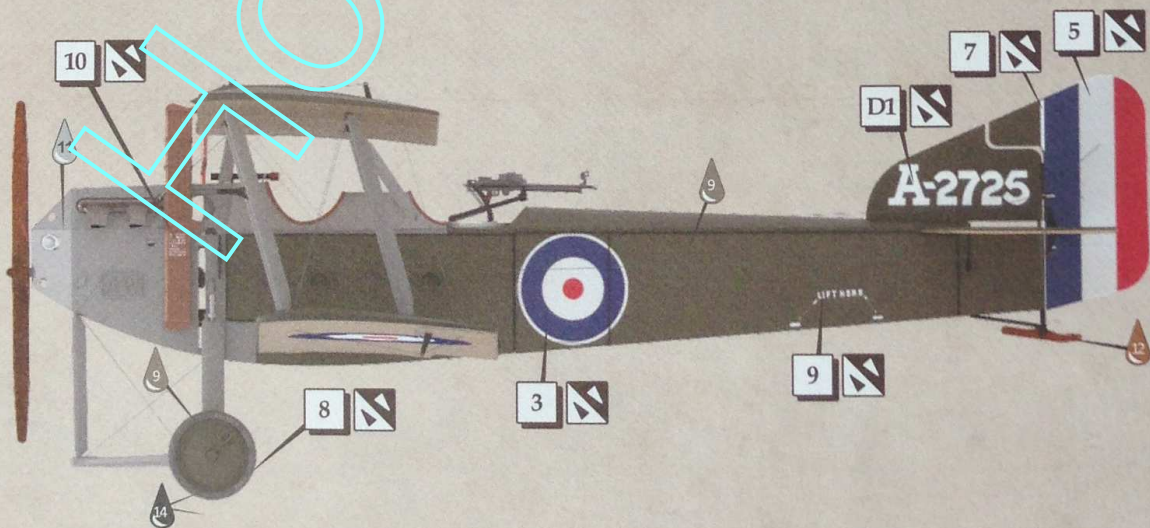

# XII Colours and markings Mid. version

**B** Armstrong Whitworth F.K.8 B5773 No.2 Sqn RFC, 2Lt. Alan A. McLeod won the Victoria Cross flying this aeroplane on 27 March 1918

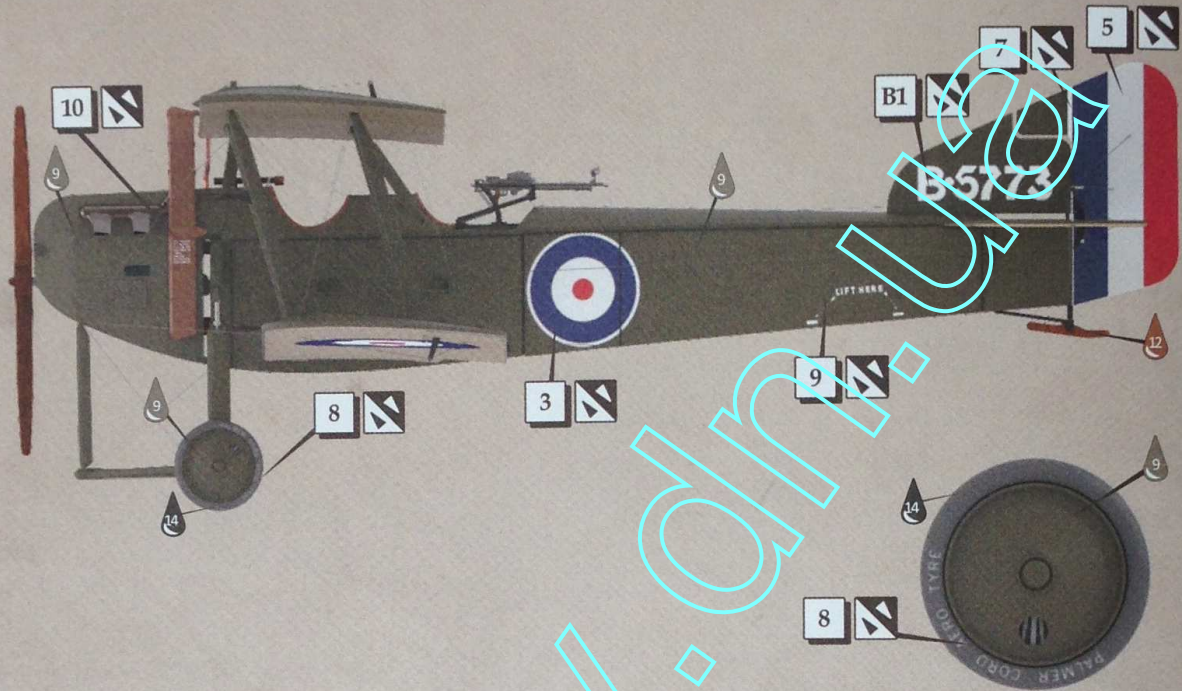

**D** Armstrong Whitworth F.K.8 C.3549 No. 35 Sqn RFC, December 1917

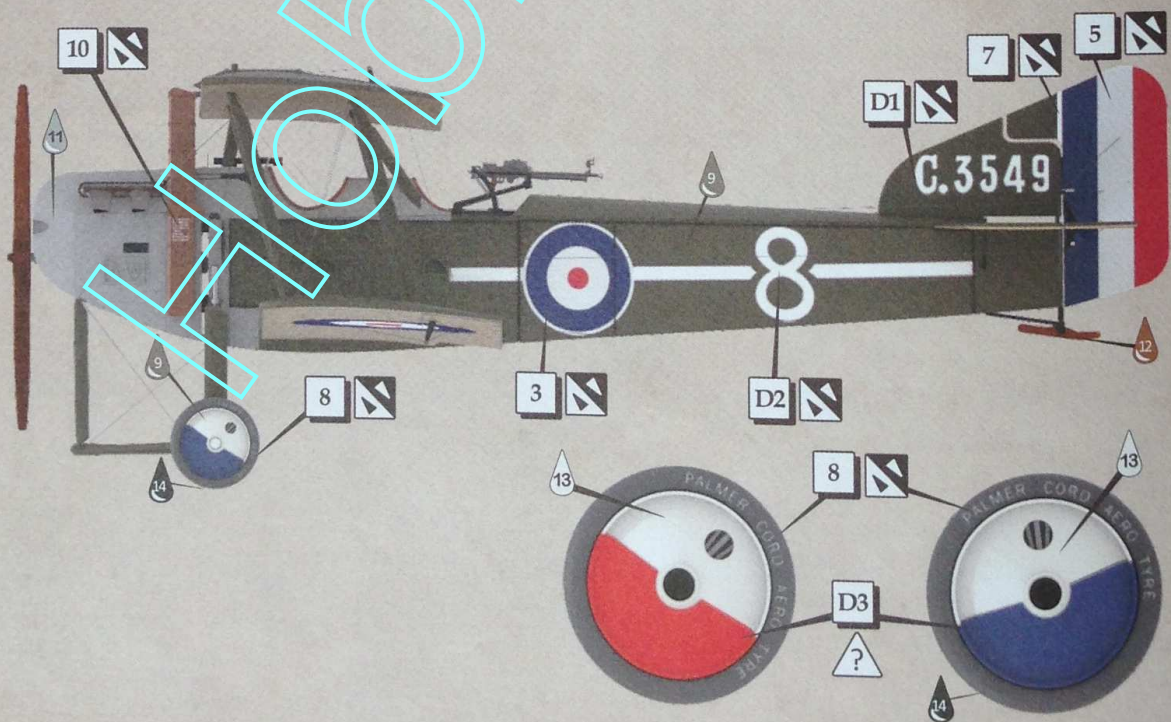

# XII Colours and markings Late version

**A** Armstrong Whitworth F.K.8 C8602 No.8 Sqn RAF, Capt. West won the Victoria Cross flying this machine on 10 August 1918

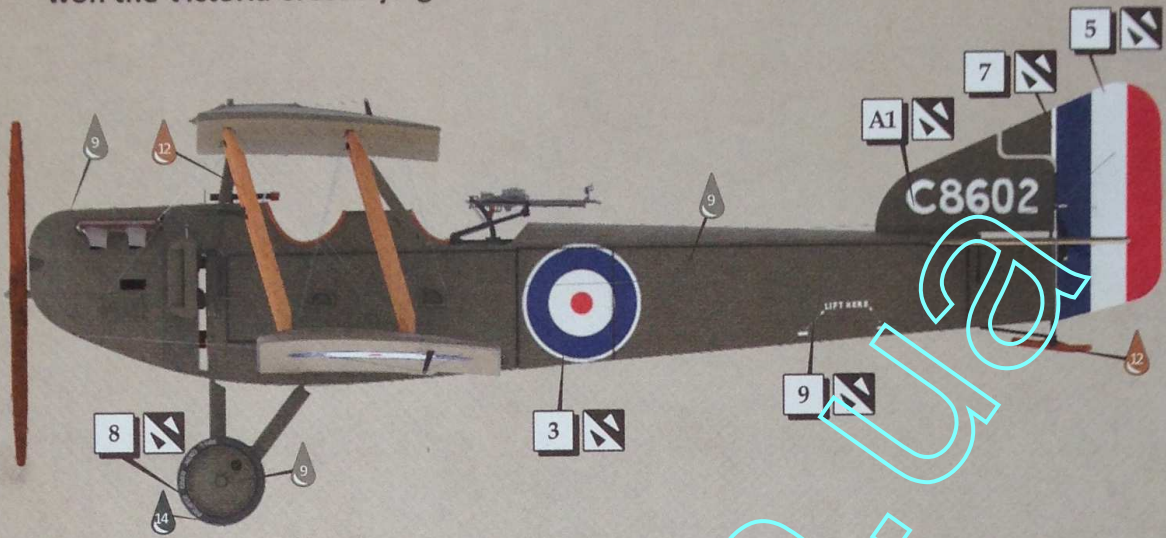

**C** Armstrong Whitworth F.K.8 C.8636 No.82 Sqn RAF, Summer 1918

