

DW 48003



TP-63E Kingcobra

1/48 SCALE MODEL CONSTRUCTION KIT

Ready to assemble scale models kit.

Contains part for one model.

Model length: 208 mm

Wingspan: 244 mm

Plastic parts: 136

Photoetched parts: 34

An entirely different two-seater was produced by the Bell company for internal use. Two P-63F-1s were modified by Bell with a separate observer seat in the rear fuselage, located behind the engine and mounted under a separate canopy. A probe was mounted which extended through the spinner, and to make space for the observer the radio equipment had to be moved forward into the armament bay. The aircraft carried the civilian registrations NX41963 and NX41964.

PARTS OF THE MODEL

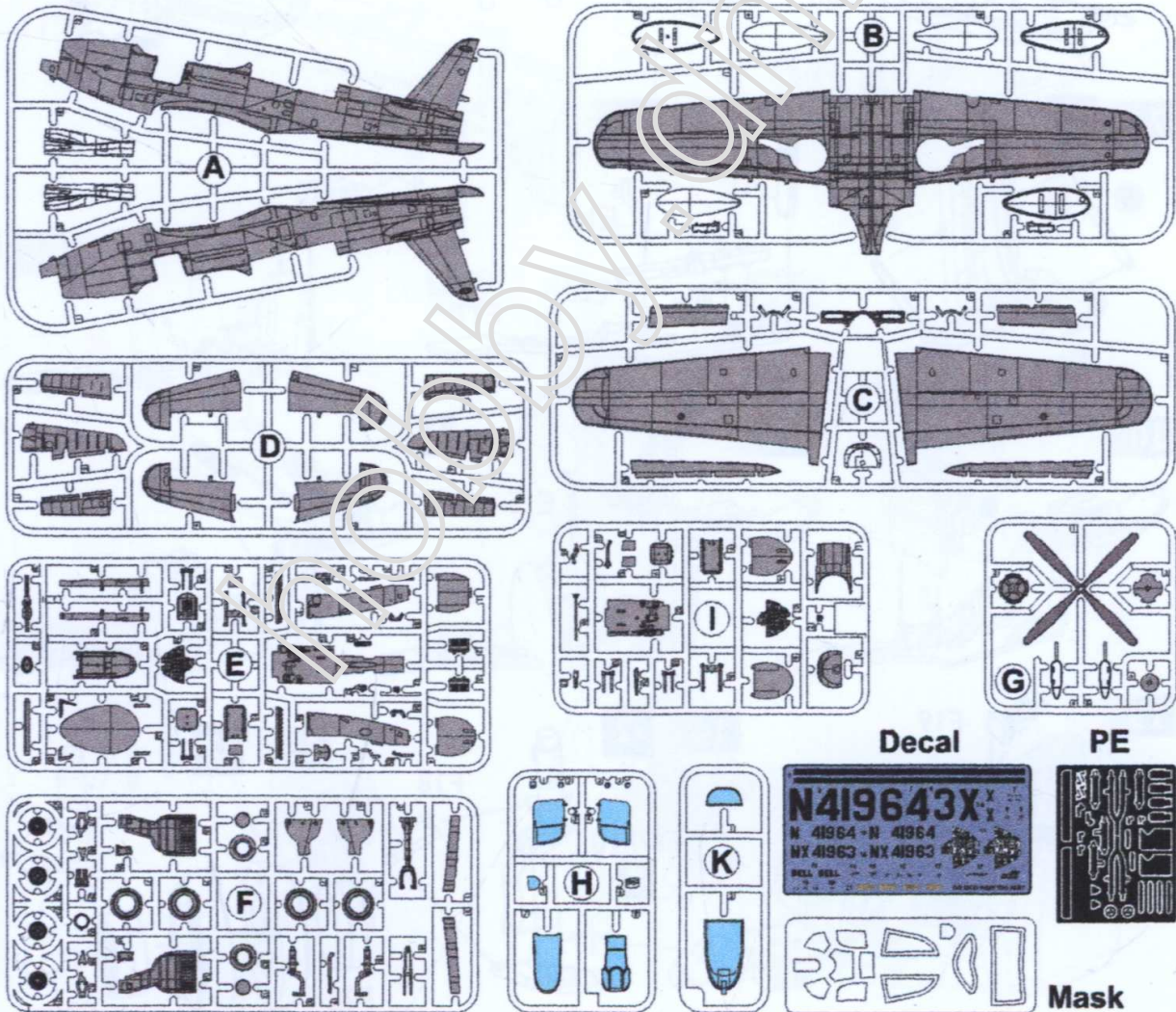

ASSEMBLY INSTRUCTION

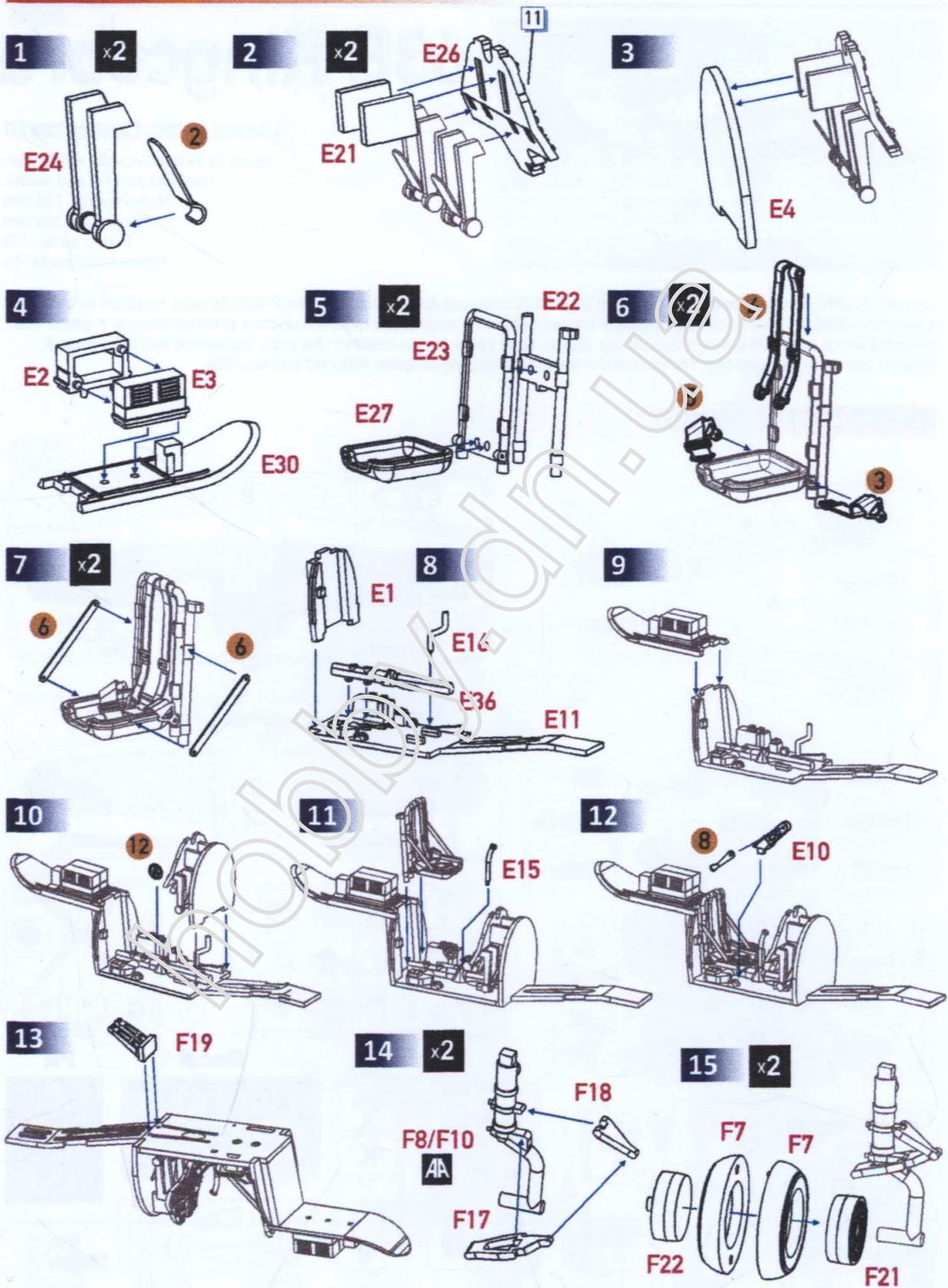

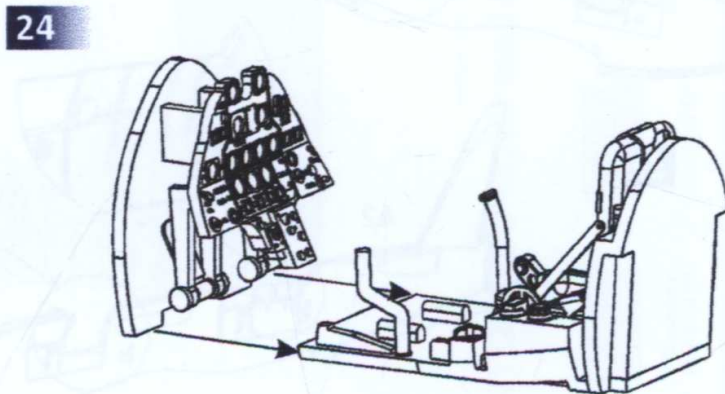
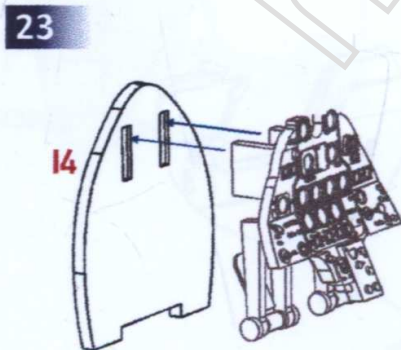
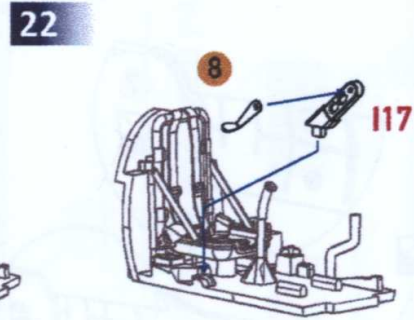
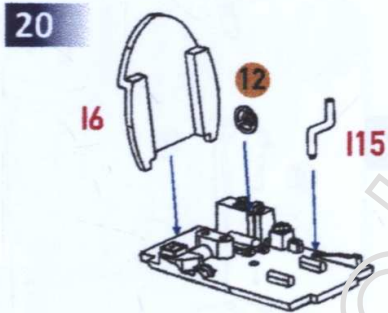
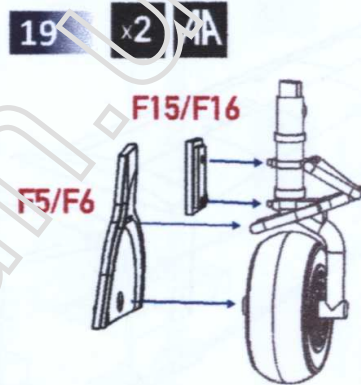
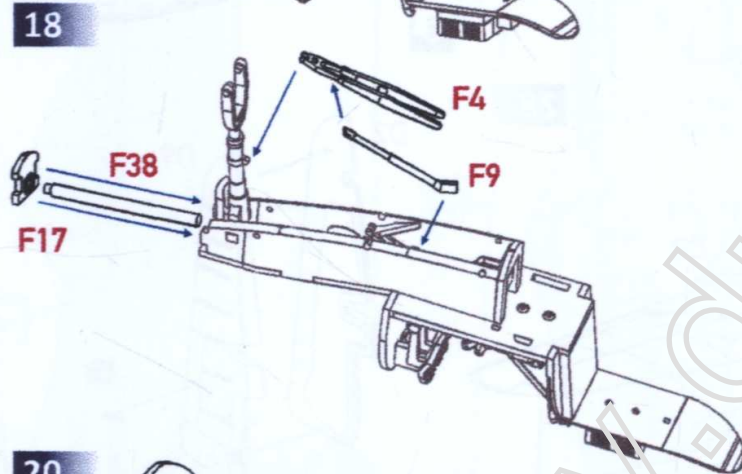
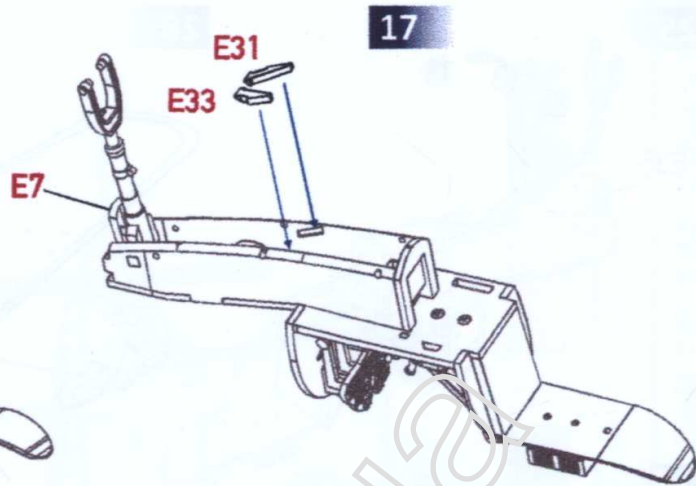
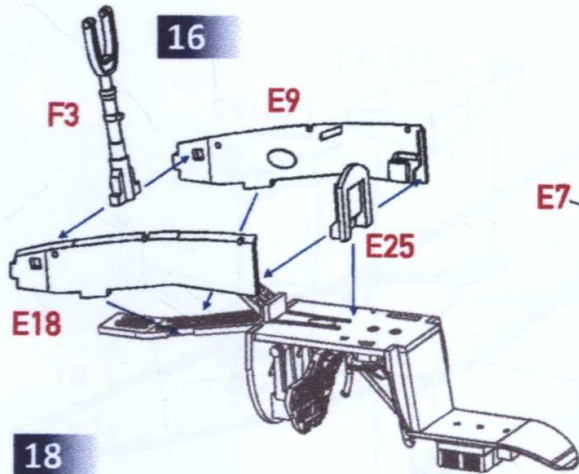

25

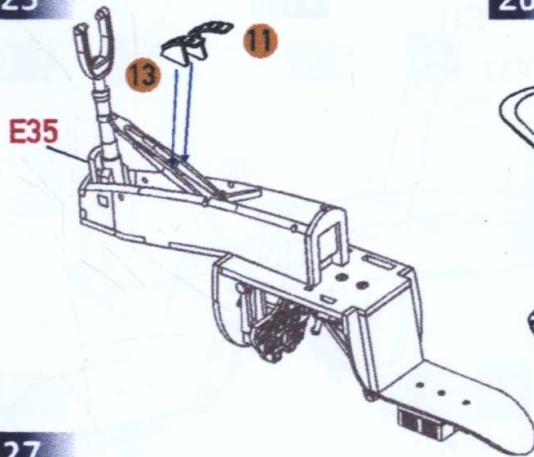

26

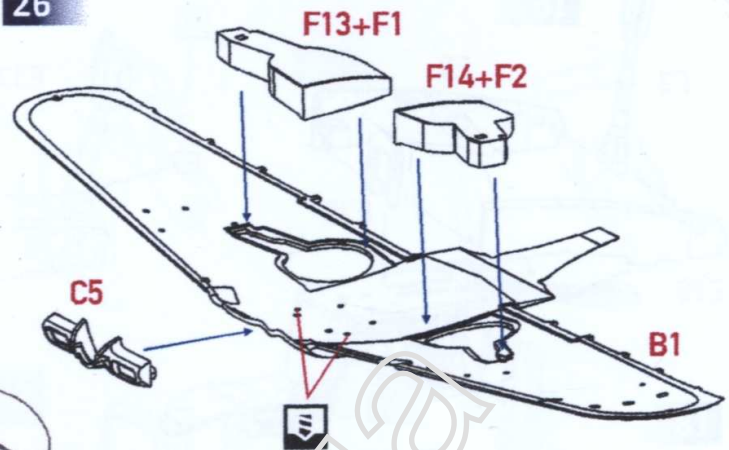

27

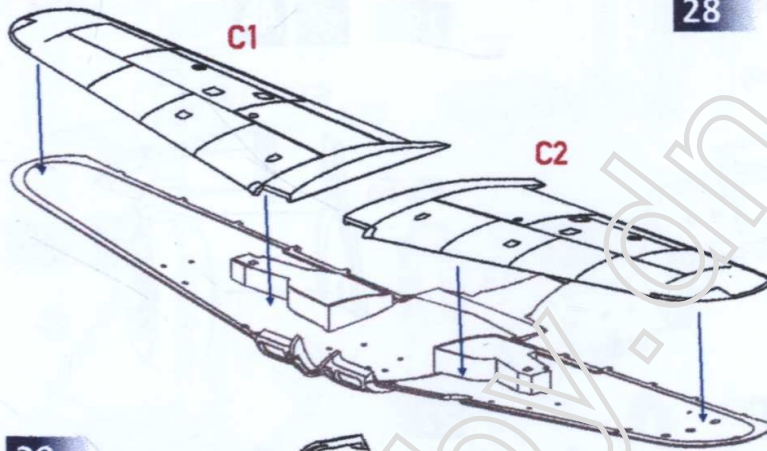

28

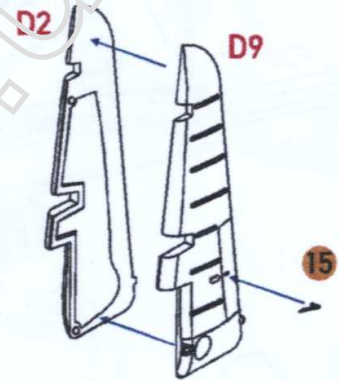

29

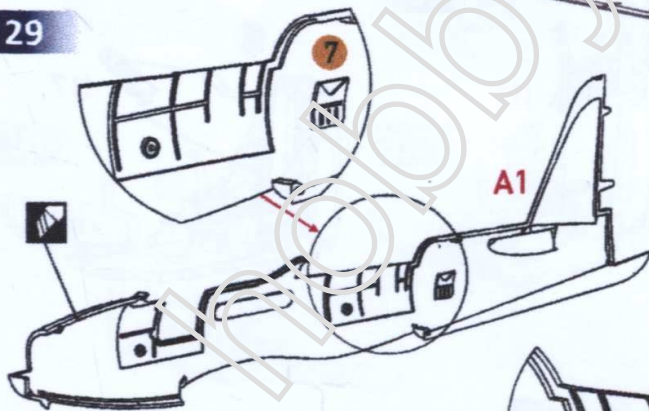

30

x2

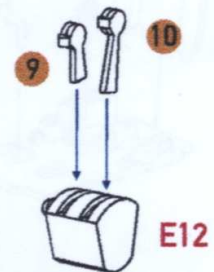

31

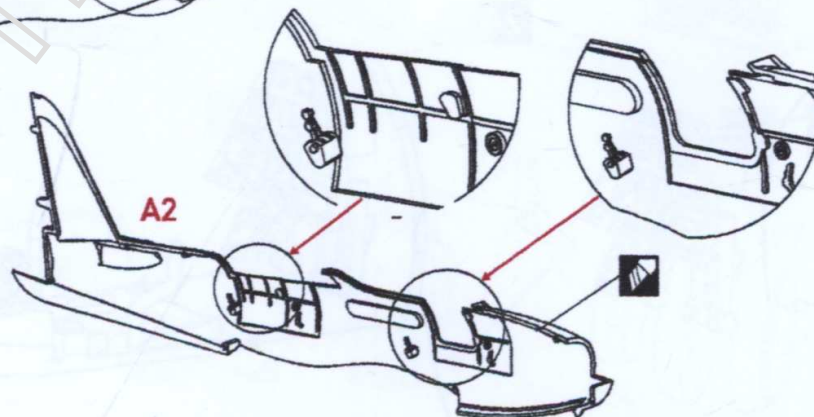

32

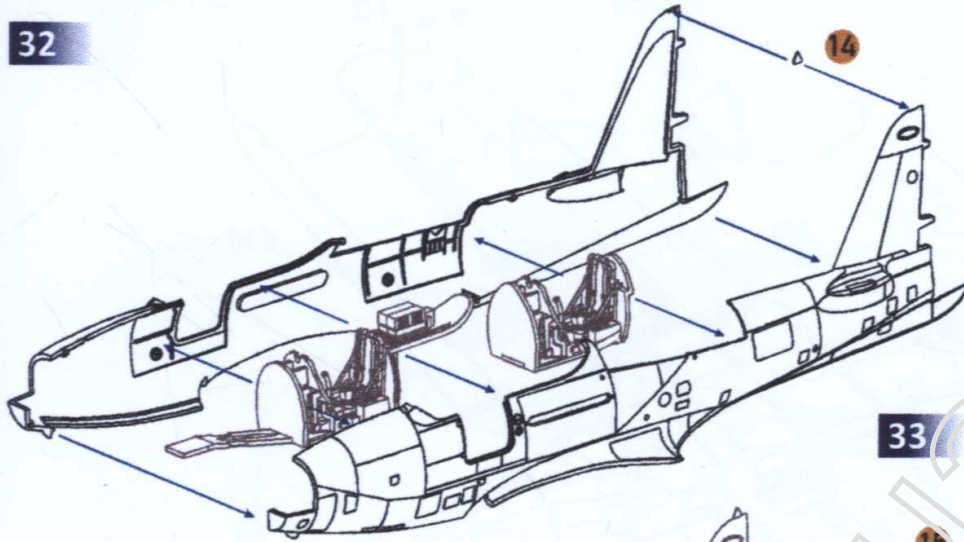

33

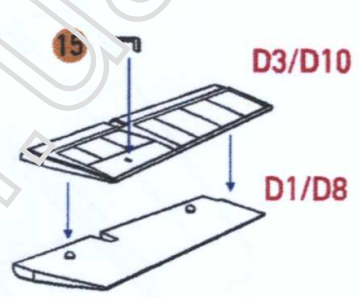

34

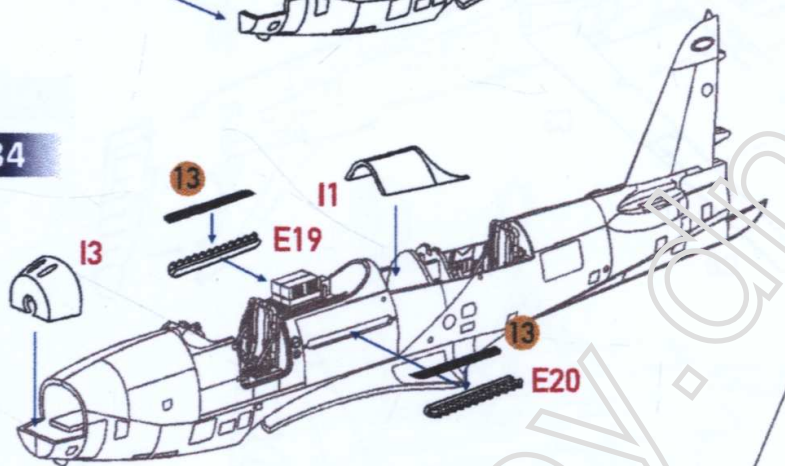

35

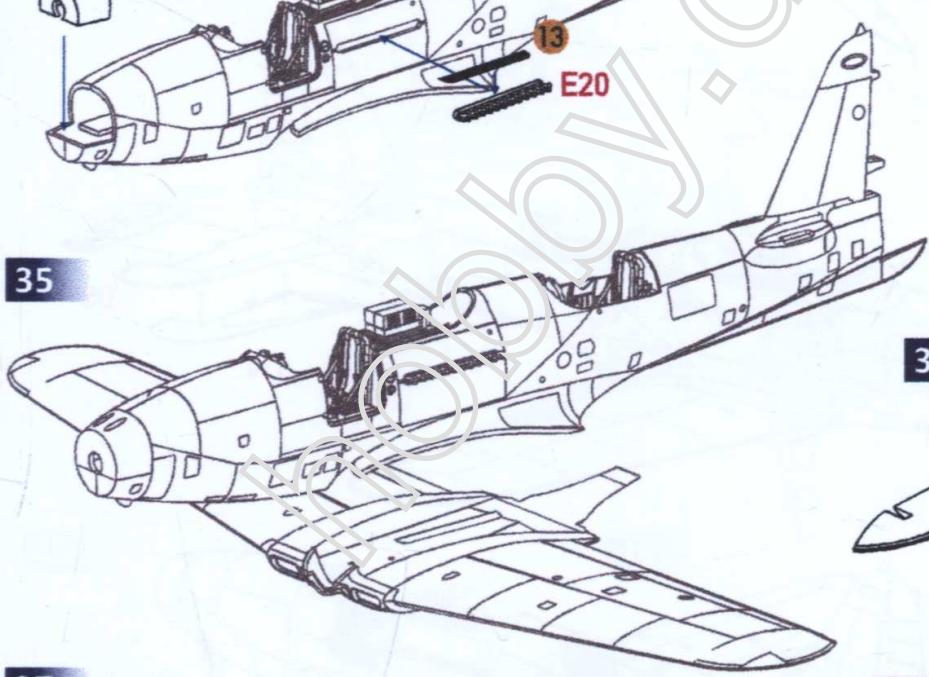

36

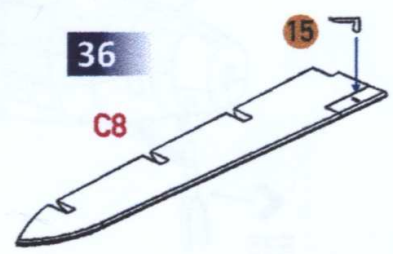

37

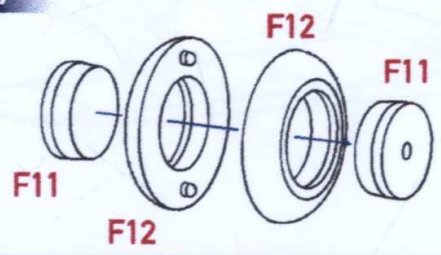

38



39

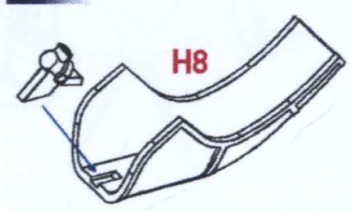

40

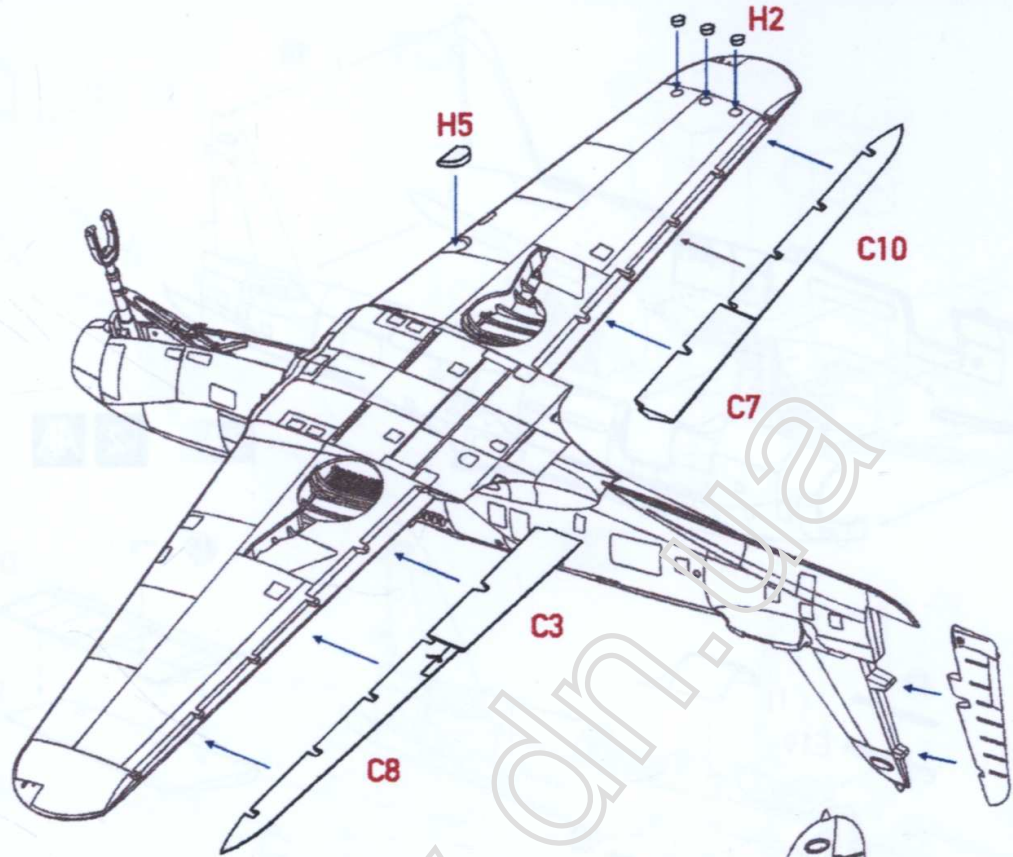

41

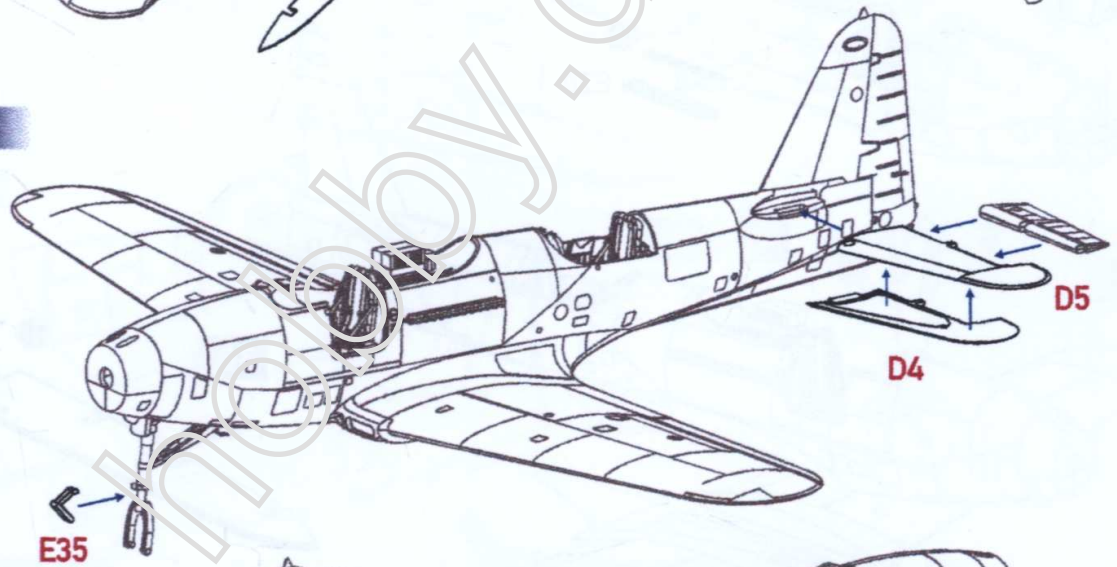

42

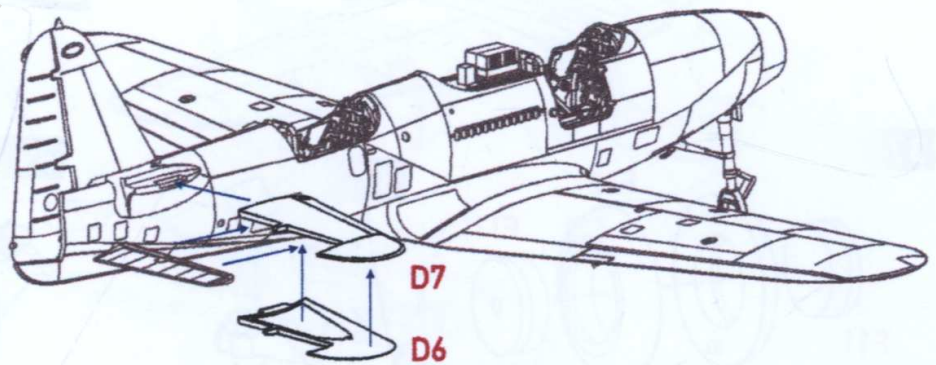

43

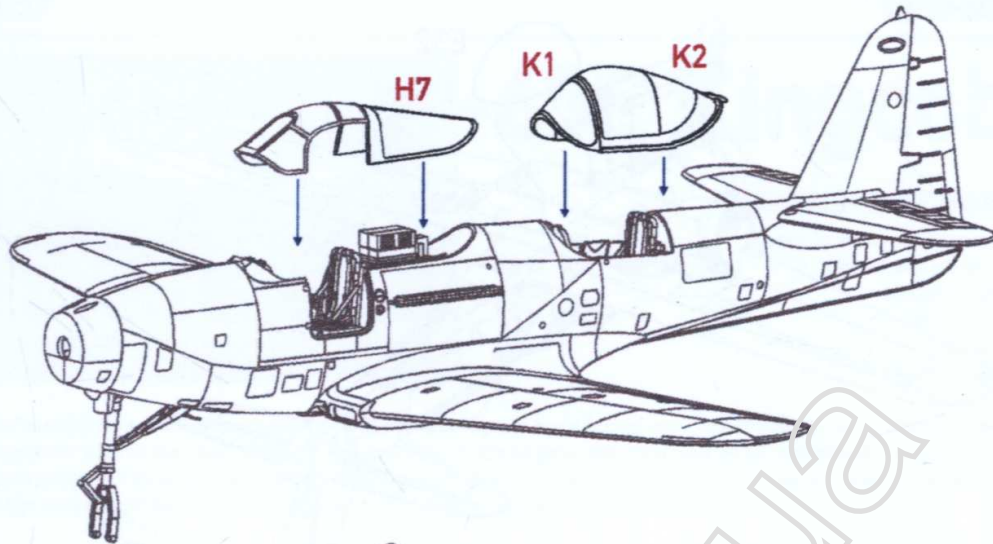

44

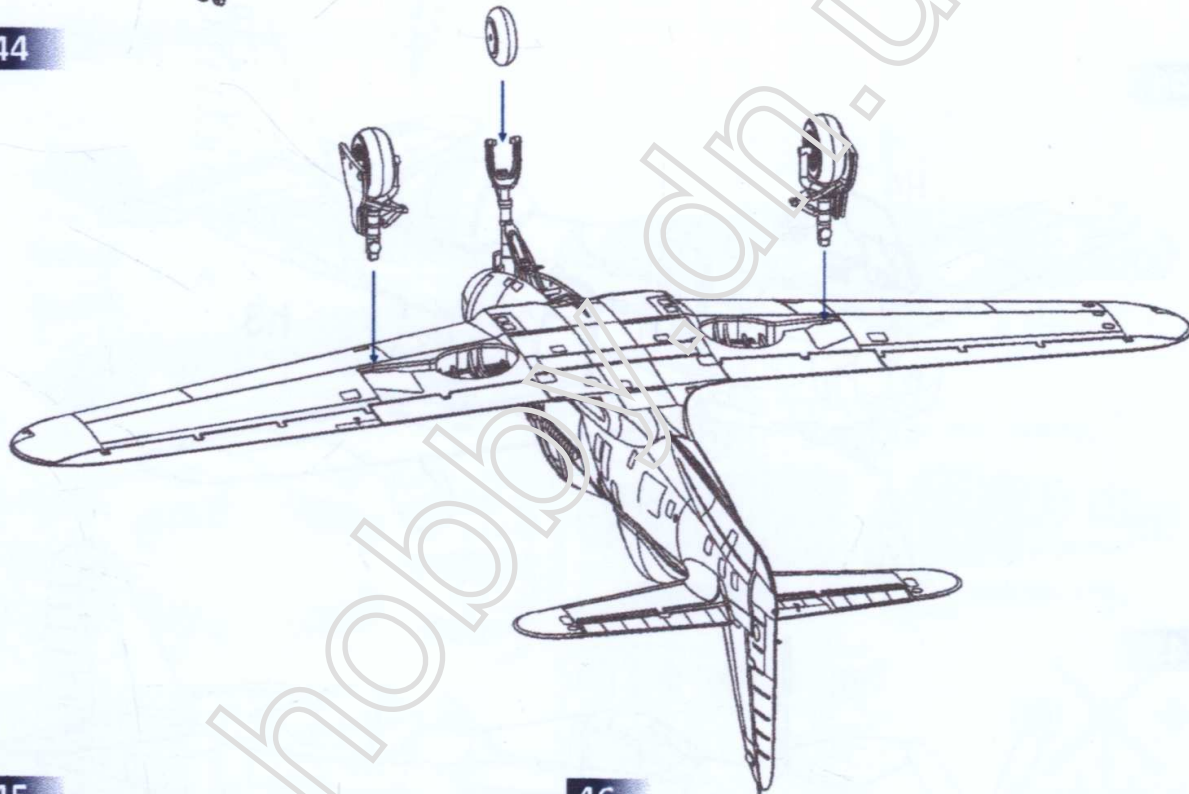

45

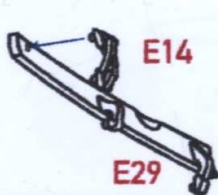

46

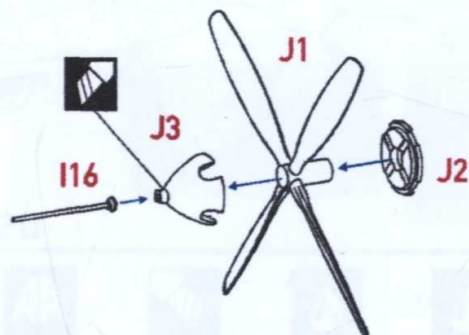

47

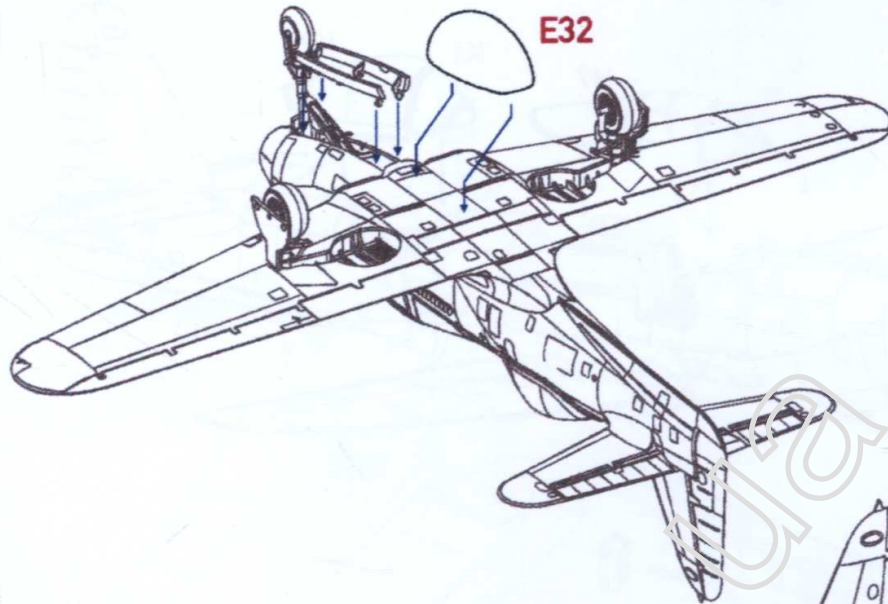

48

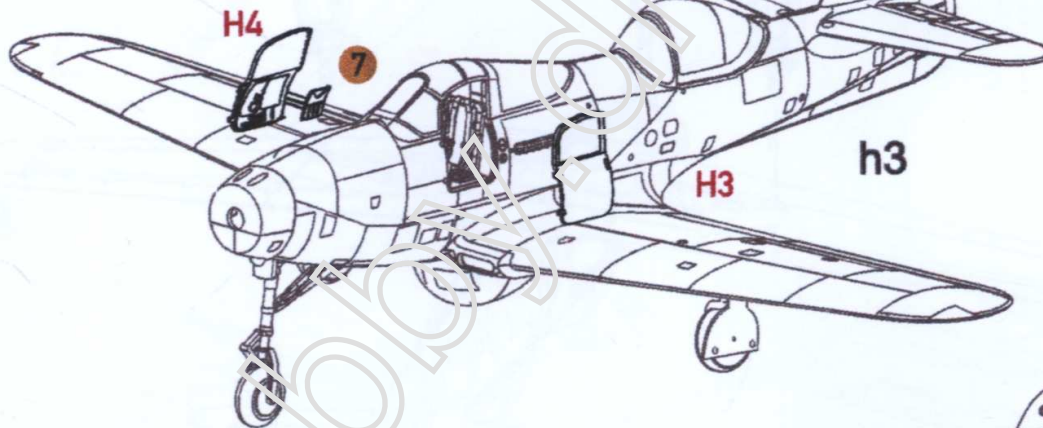

49

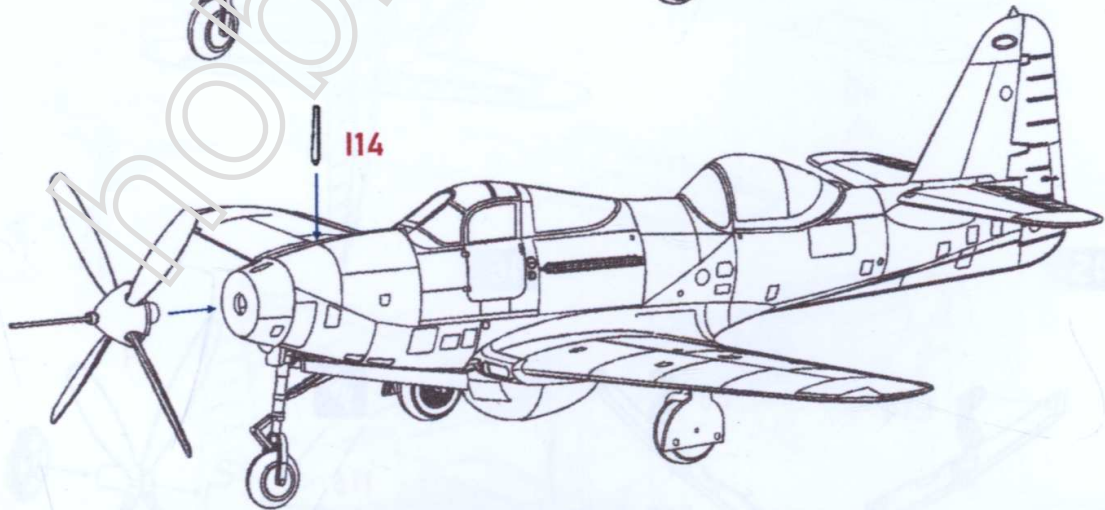

USED SYMBOLS

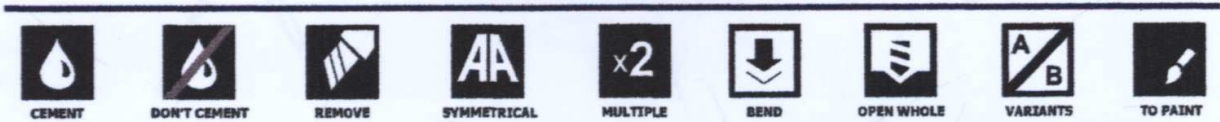

COLOR SCHEME

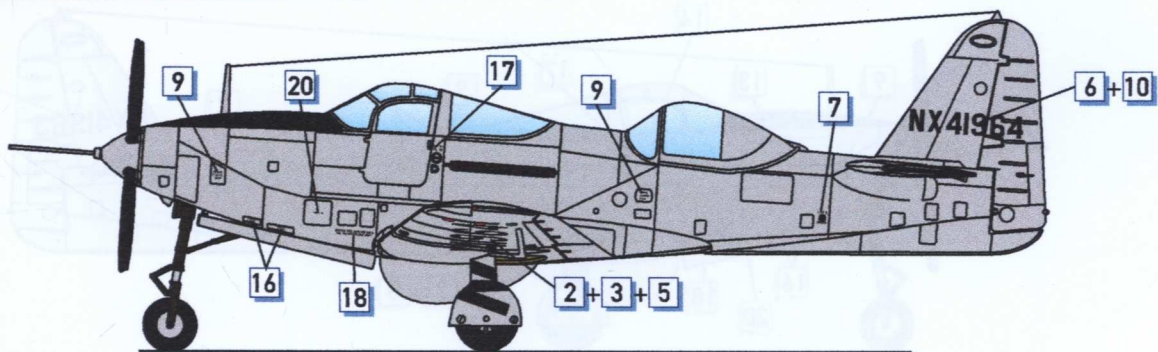

1) Civil two-seater mod NX 41964, General Electric Air Research Demonstration Schenectady, New York, June 22, 1946

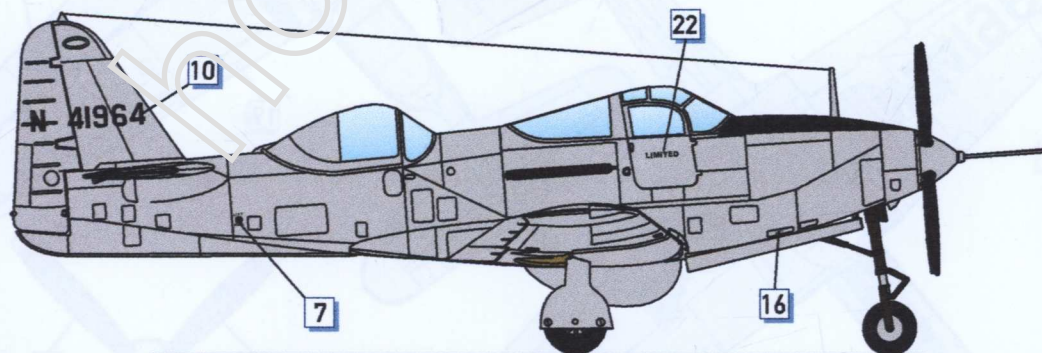
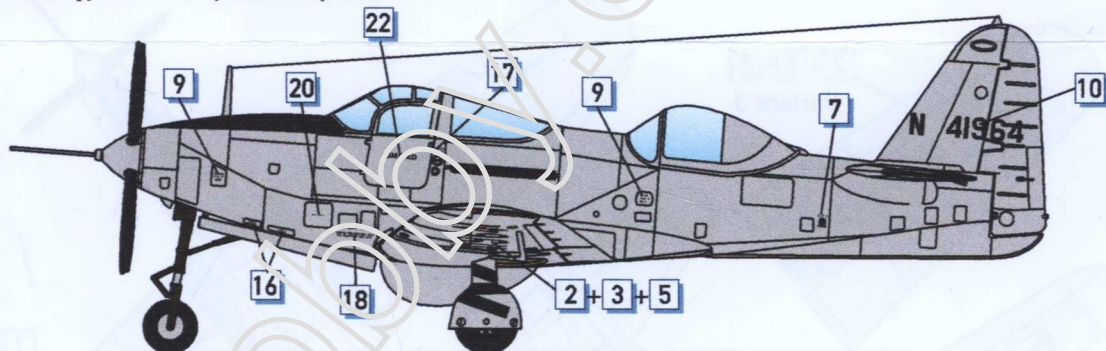

2) Civil two-seater mod NX41964, exported FA Hondurena, October 1948



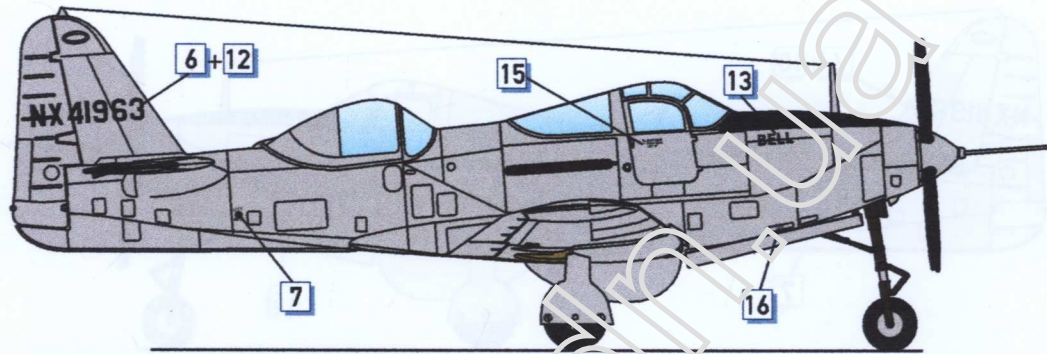
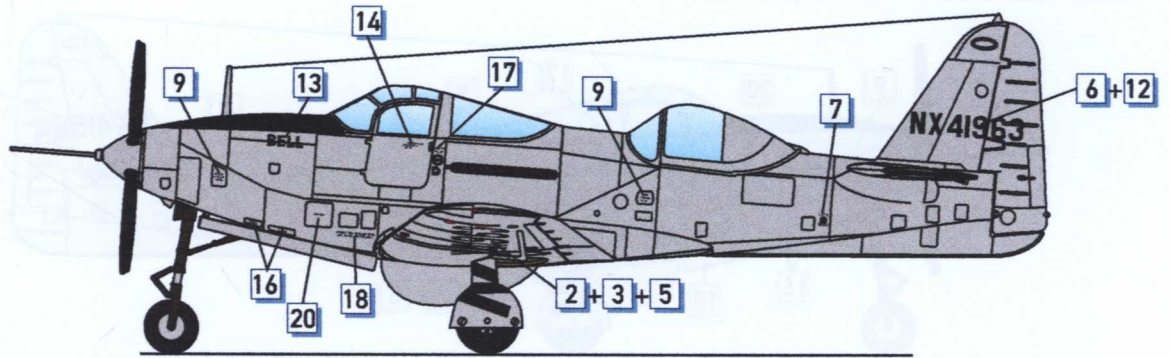

3) Civil two-seater mod NX 41963, May 1947

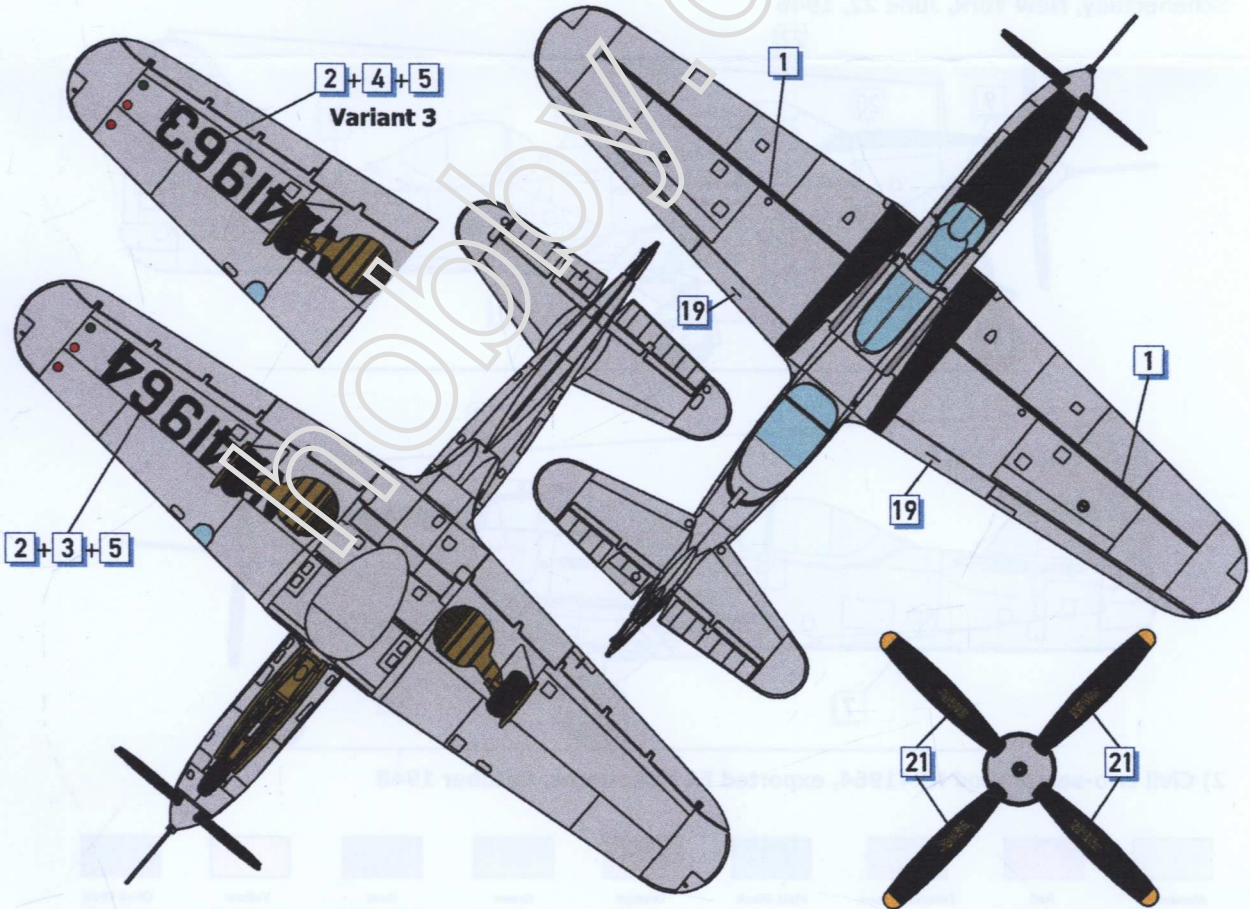

Bell TP-63E Kingcobra