

INTRO

The MiG-21 was one of a long list of Mikoyan-Gurevich products to be integrated into the armed forces of the Soviet Union, the Warsaw Pact, and allied client states. Its predecessors included such notable types as the MiG-15, MiG-17 and the supersonic MiG-19. The roots of this project reach back to the first half of the fifties. In 1954, the Ye-1 project came to an end, and was quickly picked up by the Ye-2. Both had a swept wing. The first machine to feature the delta wing was the Ye-4, which first took to the air on June 16th, 1955. It was also demonstrated a year later at the Moscow airfield Tushino. The first of the new line to enter production was the MiG-21F, which together with the MiG-21P and F-13 represented the first generation of the MiG-21, and was in production through the end of the fifties and the beginning of the sixties. Subsequent versions included the PF, FL, PFM, R the production of which peaked at the end of the sixties. The third generation started production in 1968, which included such versions as M, SM, MF, SMT, bis among others. Simultaneously, two-seat training versions were also produced designated MiG-21U, UM and US. Production of the MiG-21 ended in 1985, and was put into service with some fifty nations. Over the course of the cold war, the opponents of the MiG-21 included the likes of the Northrop F-5 Freedom Fighter and the Dassault Mirage III. NATO assigned it the reporting name 'Fishbed'. It became the most produced supersonic fighter in terms of quantity. The new machines came off Soviet production lines in Moscow, Gorky and Tbilisi. The MiG-21F-13 was also built under license in Czechoslovakia and the MiG-21FL, M and bis in India by Hindustan Aeronautics Ltd. The Soviet Union produced 10,645 examples of all versions, 194 were built in Czechoslovakia and 657 in India. Outside of the Soviet Union, the type flew with a long list of nations on all continents with the exception of Australia. The MiG-21 participated in combat in Vietnam, the Indo-Pakistan wars, the Cuban participation in Angola and in the Arab world's attempt to eliminate Israel. Thanks to the high volume of use, the highest number of aces produced on the type was in Vietnam. The top of the ladder is occupied by Nguyen Van Coc with nine kills. The type serving as a interceptor served with the Soviet Union and other nations of the Warsaw Pact into the eighties, when it began to be displaced by the MiG-29 Fulcrum.

From this kit you can build MiG-21PFM. In the factory documentation this version is identified as Izdelye 94A for the export aircraft and Izdelye 94 for the aircraft destined to the Soviet Air Force. It originated from the significant modernization of the MiG-21PF type and since 1963 was simultaneously manufactured for the Soviet Air Defense units in the Gorky plant. Since 1966 it was manufactured for export in the Moscow plant. In the beginning of 1968, it was replaced by slightly improved version capable of carrying GP-9 cannon container under the fuselage containing 23mm twin barrel cannon GSh-23 with 200 rounds or a nuclear bomb. Some users distinguish both versions as MiG-21SPS and MiG-21SPS-K respectively but mostly both versions are marked as MiG-21PFM only. MiG-21PFM production was terminated in 1968. The aircraft powerplant was Tumanskyi R-11F2-300. The outer ordnance consisted of RS-2US rockets or UB-16-57 rocket launchers, anti-ground unguided rockets S-24 and bombs up to 500 kilos. The aircraft NATO code name was Fishbed F.

PLASTIC PARTS

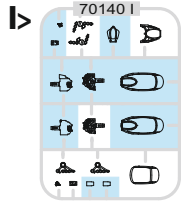
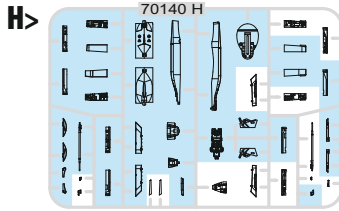
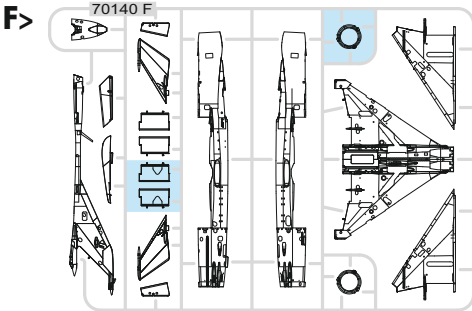
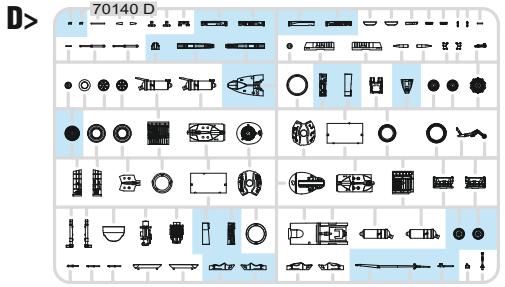
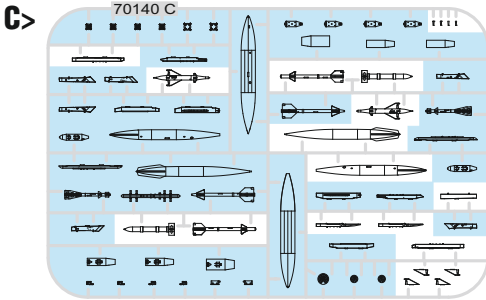

GSI Creos (GUNZE)			MISSION MODELS
AQUEOUS	Mr. COLOR	PAINTS	
H1	C1	MMP-001	WHITE
H3	C3	MMP-003	RED
H4	C4	MMP-007	YELLOW
H5	C5	MMP-048	BLUE
H11	C62	MMP-001	FLAT WHITE
H12	C33	MMP-047	FLAT BLACK
H13	C3	MMP-003	FLAT RED
H26	C66		BRIGHT GREEN
H27	C44		TAN
H47	C41	MMP-012	RED BROWN
H51	C11	MMP-063	LIGHT GULL GRAY
H53	C13		NEUTRAL GRAY
H77	C137	MMP-040	TIRE BLACK

GSI Creos (GUNZE)			MISSION MODELS
AQUEOUS	Mr. COLOR	PAINTS	
H61	C55	MMP-023	KHAKI
H61	C48		CLEAR YELLOW
H64	C42		MAHOGANY
H60	C47		CLEAR RED
H64	C138		CLEAR GREEN
H304	C304	MMP-026	OLIVE DRAB
H308	C308		GRAY
H302	C332		LIGHT AIRCRAFT GRAY
H333	C333	MMP-138	EXTRA DARK SEAGRAY
H337	C337		GRAYISH BLUE
Mr. METAL COLOR		METALLICS	
MC213		MMM-006	STEEL
MC214		MMM-001	DARK IRON
MC218		MMM-003	ALUMINIUM
Mr. COLOR SUPER METALLIC		METALLICS	
SM201		MMC-001	SUPER FINE SILVER 2
SM206		MMC-001	SUPER CHROME SILVER 2

-Parts not for use. -Teile werden nicht verwendet. -Pièces à ne pas utiliser. -Tyto díly nepoužívejte při stavbě. - 使用しない部品

ATTENTION * UPOZORNĚNÍ * ACHTUNG * ATTENTION

- (GB)** Carefully read instruction sheet before assembling. When you use glue or paint, do not use near open flame and use in well ventilated room. Keep out of reach of small children. Children must not be allowed to suck any part, or pull vinyl bag over the head.
- (CZ)** Před započatím stavby si pečlivě prostudujte stavební návod. Při používání barev a lepidel pracujte v dobře větrané místnosti. Lepidla ani barvy nepoužívejte v blízkosti otevřeného ohně. Model není určen malým dětem, mohlo by dojít k požití drobných dílů.
- (D)** Vor dem Zusammenbau die Bauanleitung gut durchlesen. Kleber und Farben nicht in der Nähe von offenem Feuer verwenden und für eine ausreichende Belüftung sorgen. Den Bausatz von kleinen Kindern fernhalten. Vermeiden Sie, dass Kinder Bauteile in den Mund nehmen oder sich Plastiktüten über den Kopf ziehen.
- (F)** lire soigneusement la fiche d'instructions avant d'assembler. Ne pas utiliser de colle ou de peinture à proximité d'une flamme nue, et aérer la pièce de temps en temps. Garder hors de portée des enfants en bas âge. Ne pas laisser les enfants mettre en bouche ou sucer les pièces, ou passer un sachet vinyl sur la tête.

INSTRUCTION SIGNS * INSTR. SYMBOLY * INSTRUKTION SINNBILDEN * SYMBOLES

- OPTIONAL VOLBA
- BEND OHNOUT
- SAND BROUSIT
- OPEN HOLE VYVRTAT OTVOR
- SYMMETRICAL ASSEMBLY SYMETRICKÁ MONTÁŽ
- REMOVE ODŘÍZNOUT
- REVERSE SIDE OTOČIT
- APPLY EDUARD MASK AND PAINT POUŽIT EDUARD MASK NABARVIT

1 = 85% SM2011
MMC
001 FINE SILVER + 15% H91
C48 CLEAR YELLOW

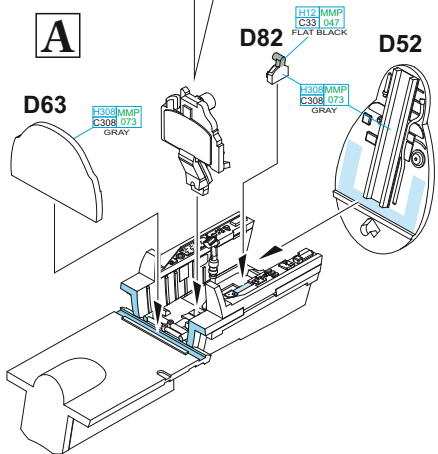
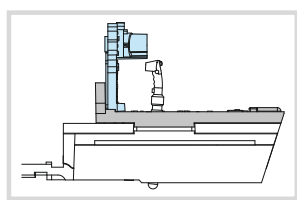
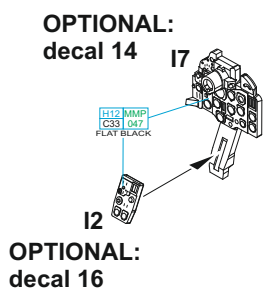
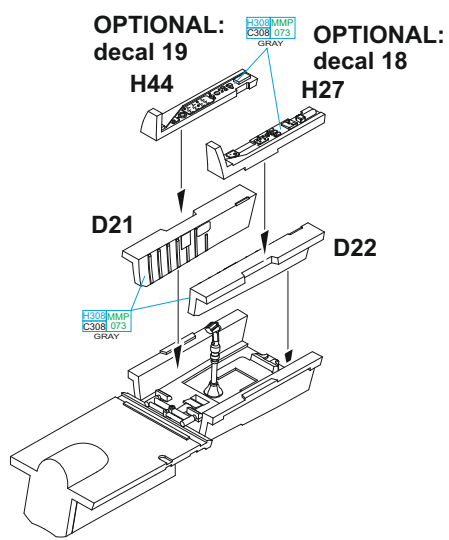
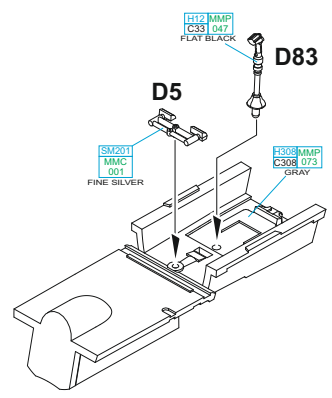
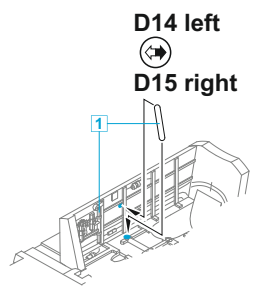
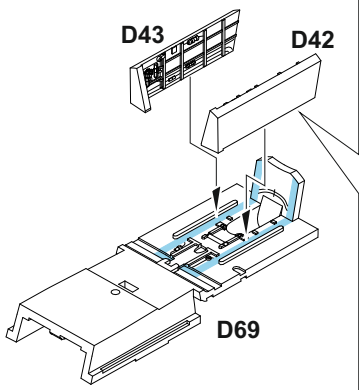

A

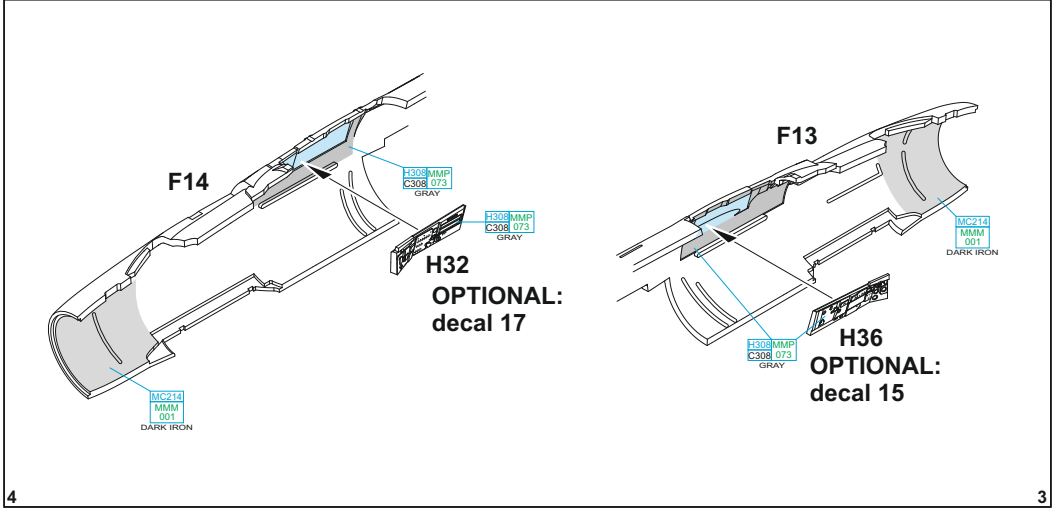
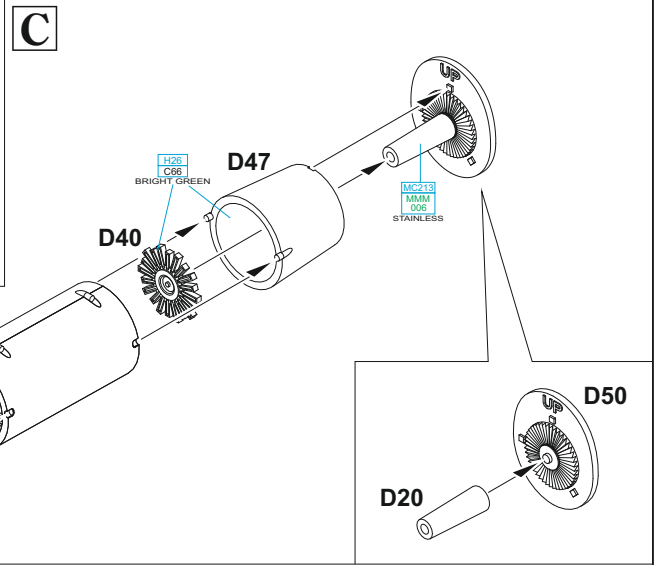
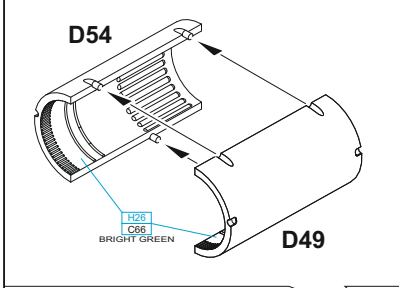
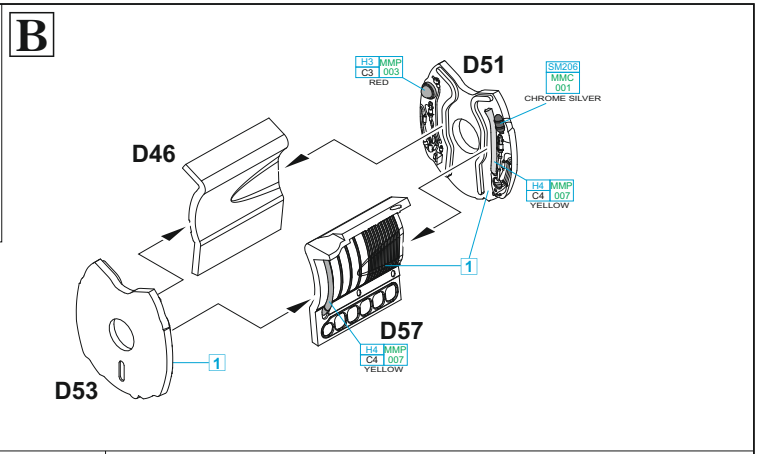
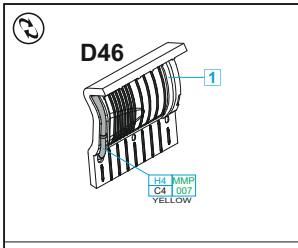

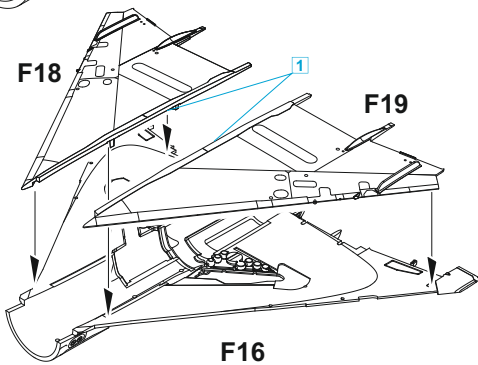
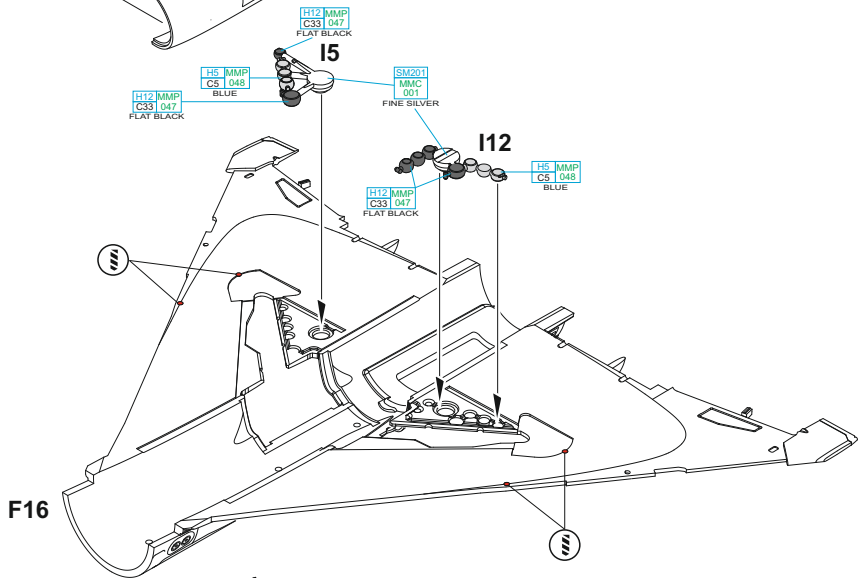
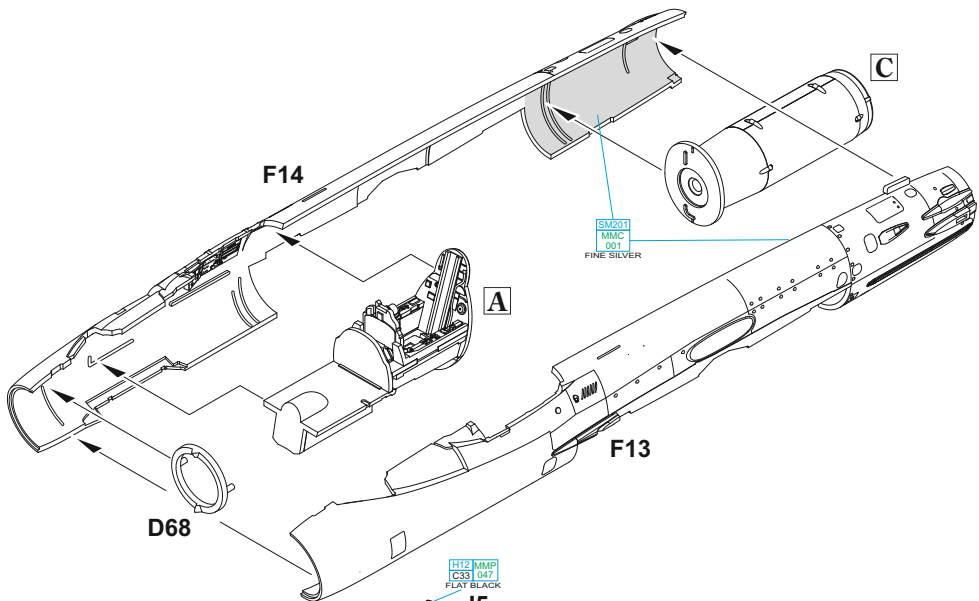

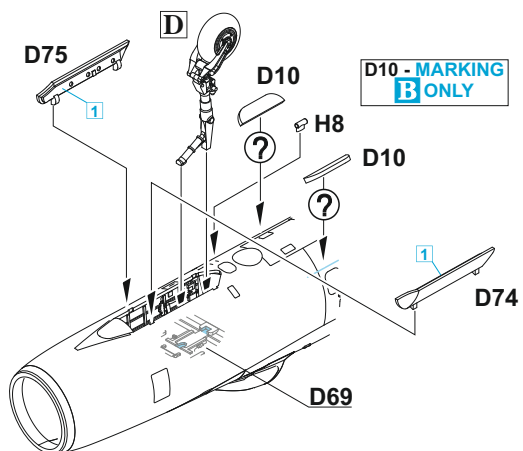
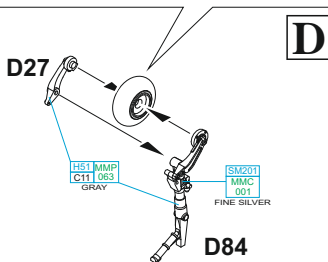
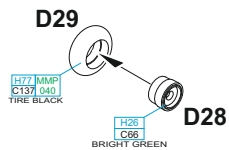
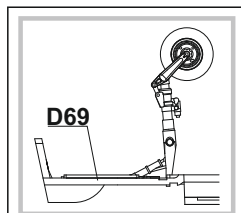
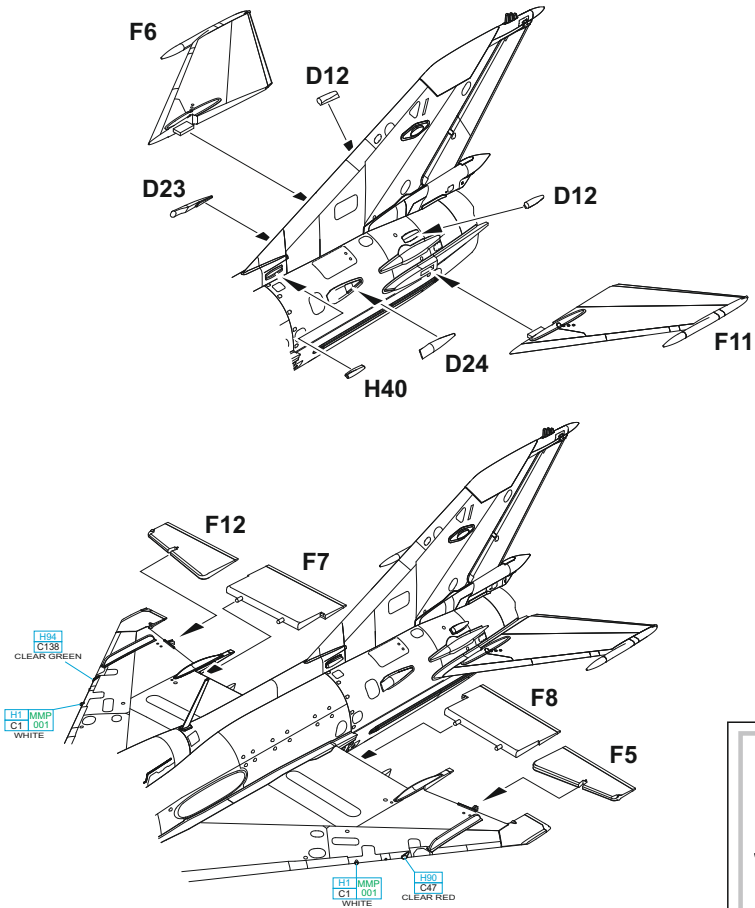

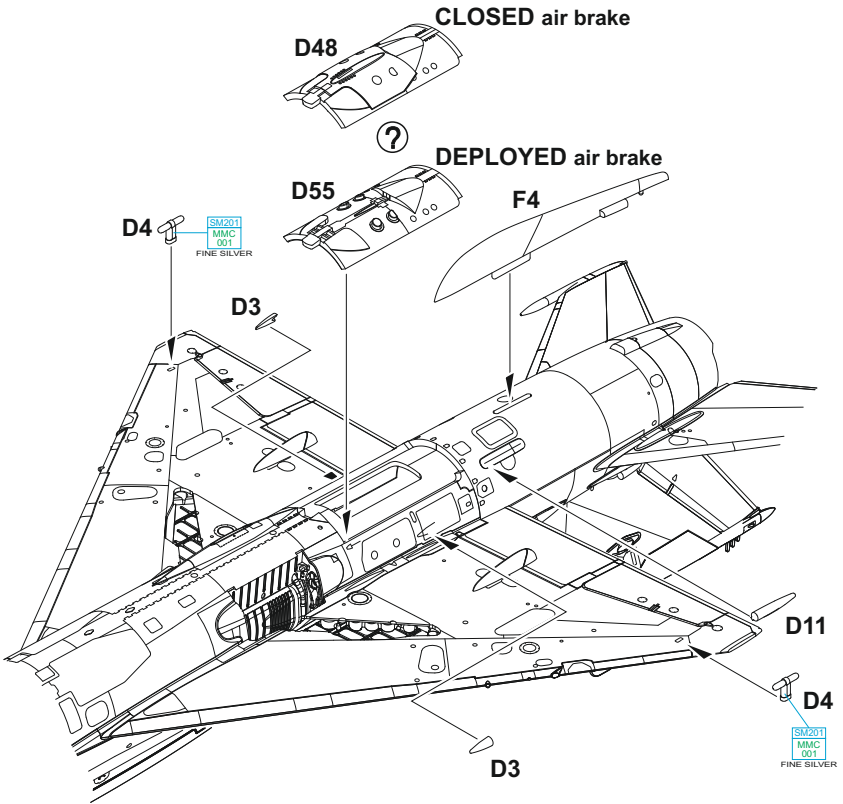

28°

D79

D78

L

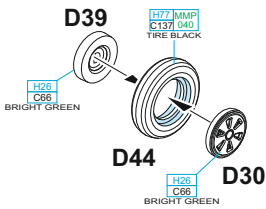
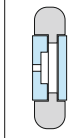

R

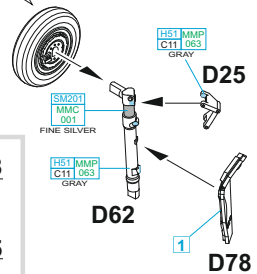
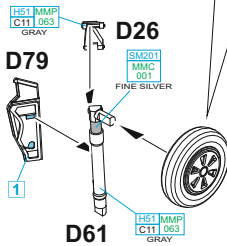
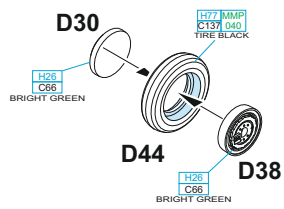
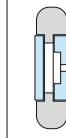

D79

D26

D78

D25

L

R

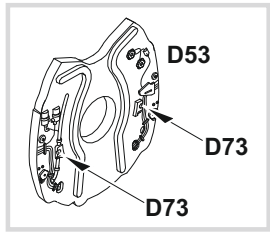
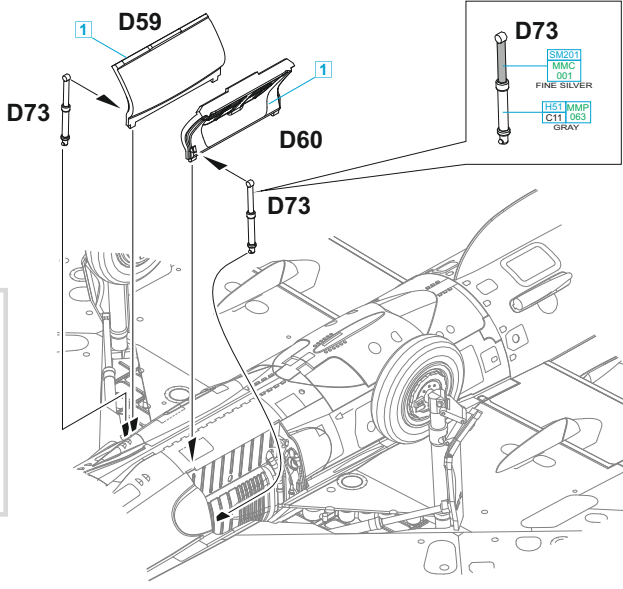
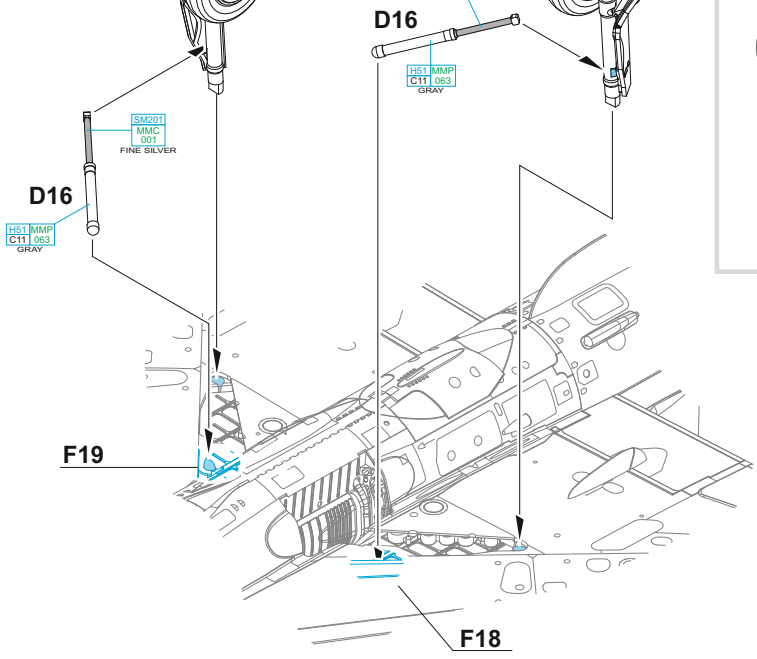
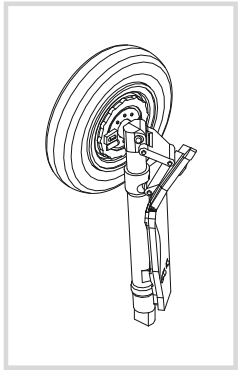

E 2 pcs.

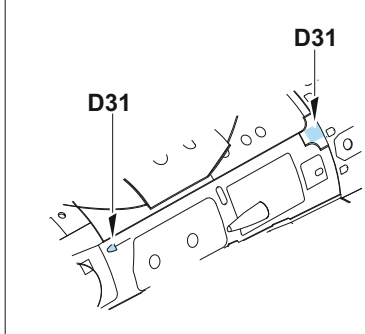
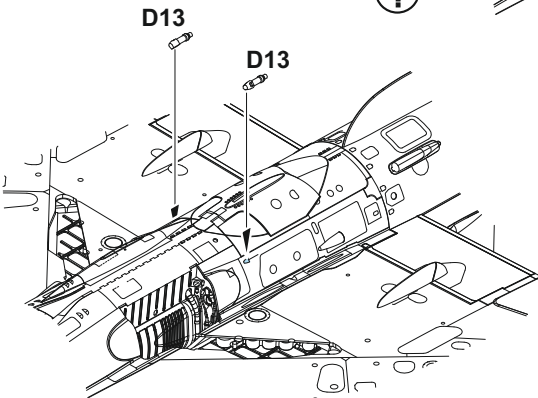
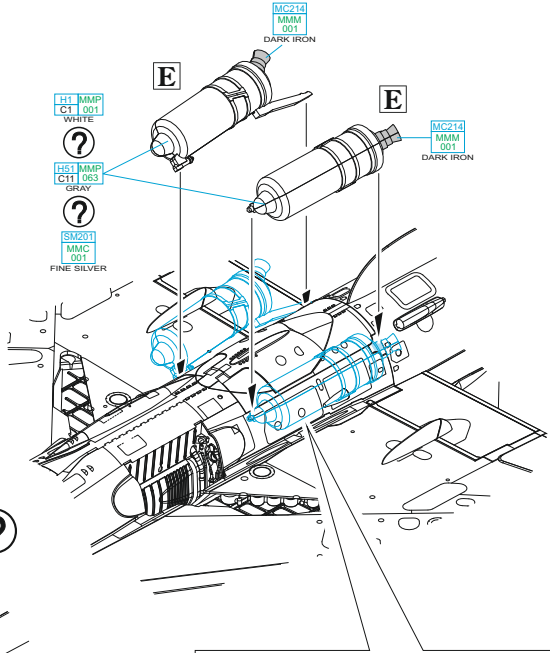
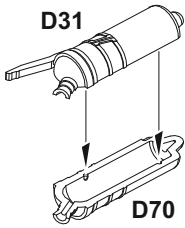

?

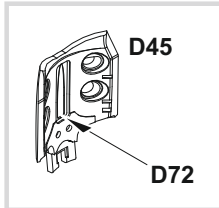
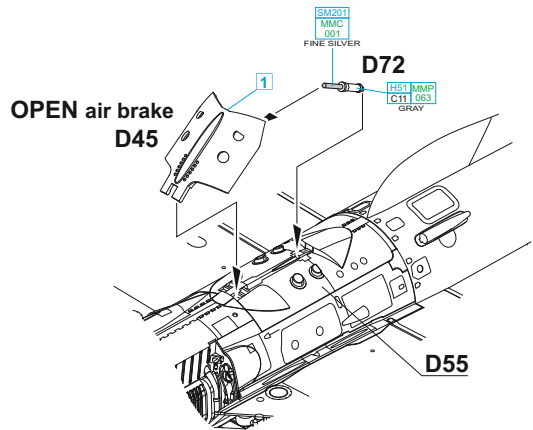

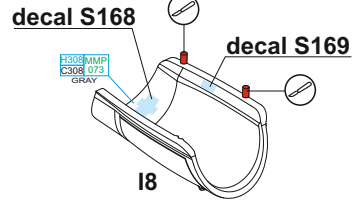
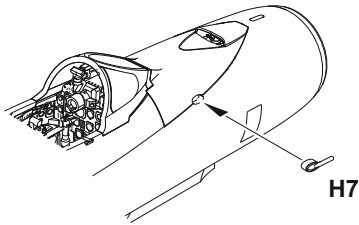
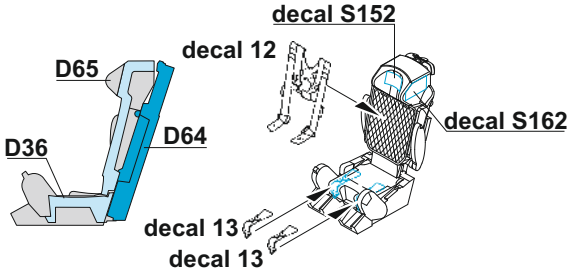
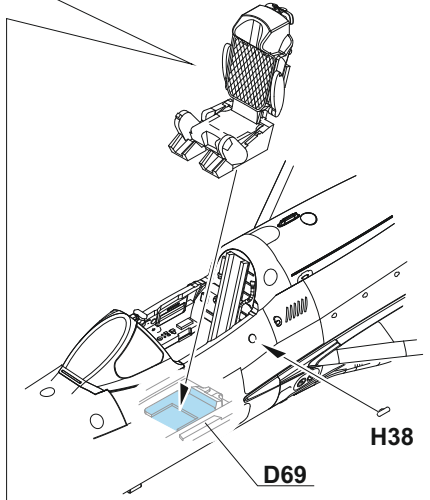
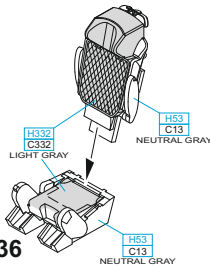
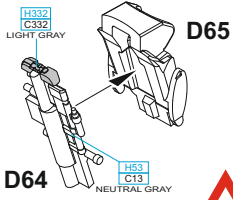

**CLOSED
CANOPY**

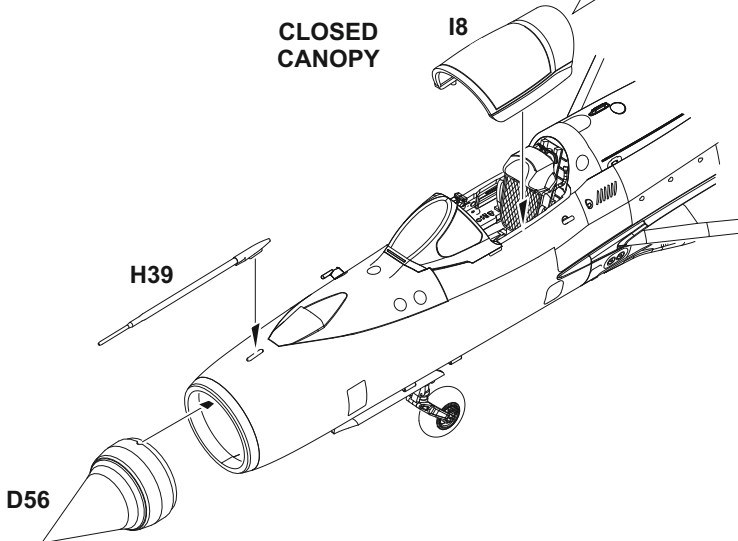

decal S168

decal S169

H308/MMP
C308 073
GRAY

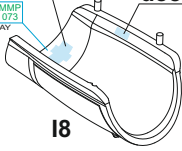

I8

I8

**OPEN
CANOPY**

D2

H308/MMP
C308 073
GRAY

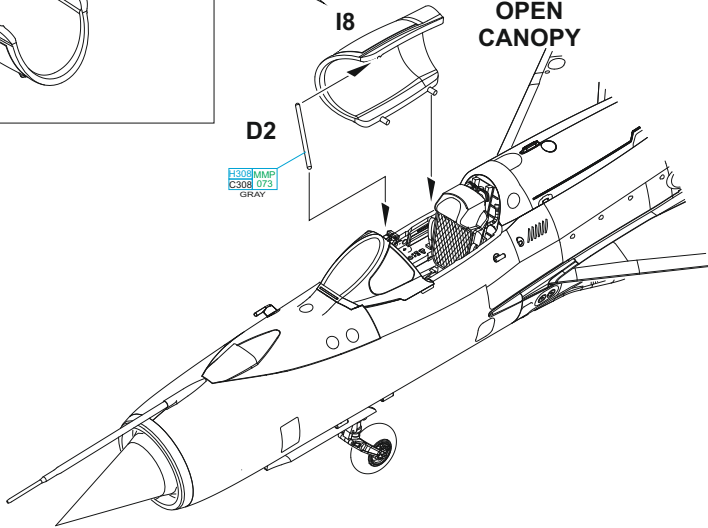

H33

C40

H28

UNDERSURFACE
COLOR

UNDERSURFACE
COLOR

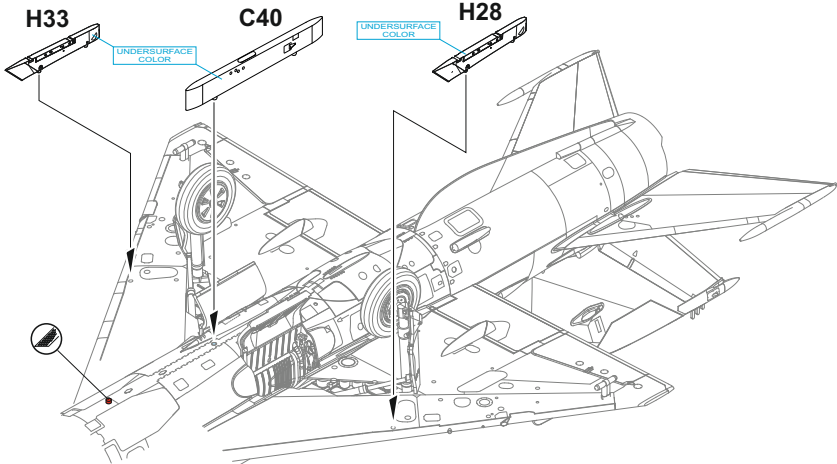

EXTERNAL FUEL TANK 490 I

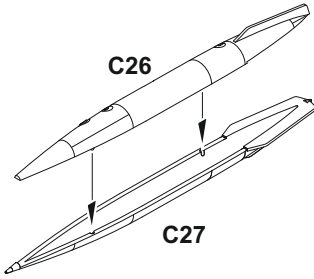

**R-3S
2 pcs.**

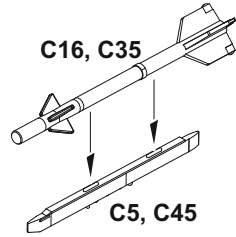

**RS-2US
2 pcs.**

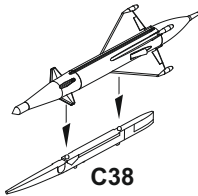
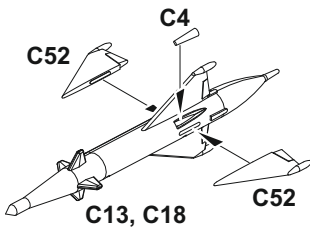

**S-24
2 pcs.**

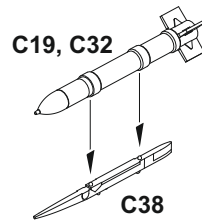

TO CHOOSE WEAPON AND EXTERNAL FUEL TANK OPTION PLEASE FOLLOW YOUR REFERENCE.

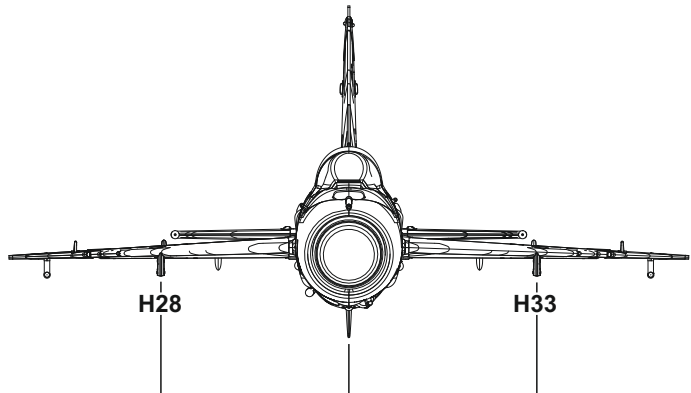

**EXTERNAL
FUEL
TANK 490 I**

MARKINGS A;B



2x RS-2US

MARKING A ONLY



2x R-3S

MARKINGS A;B



2x S-24

MARKING A ONLY



A 4401, 3rd Squadron, 1st Fighter Regiment, České Budějovice, Czechoslovakia, first half of 1969 – second half of 1970

This MiG-21PFM was delivered to Czechoslovakia in August 1966. Its first unit was the 1st Fighter Air Regiment, where it served in the 3rd Squadron, and also received a emblem of a devil with a pitchfork on the nose. It later served in the 11th Fighter Air Regiment. After being decommissioned in 1990, it was exhibited in front of the former Air Force Headquarters in Stará Boleslav, where it still stands today

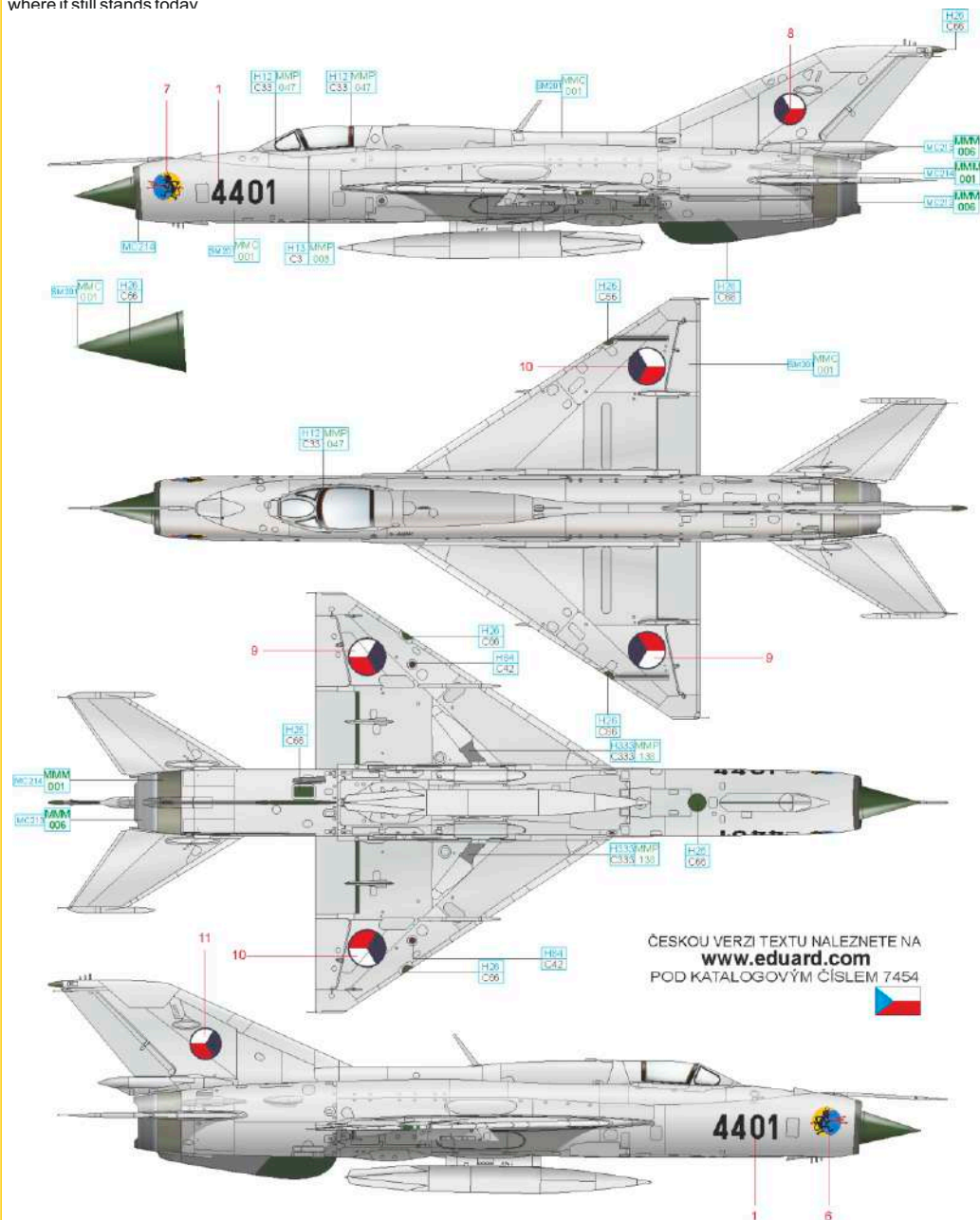

ČESKOU VERZI TEXTU NALEZNETE NA
www.eduard.com
 POD KATALOGOVÝM ČÍSLEM 7454



BLACK	H12 MMP C33 047	DARK IRON	MC214 MMA 001	GREEN	H20 C66
DARK GRAY	H33 MMP C33 138	STEEL	MC213 MMA 006	DARK BROWN	H21 C66
				RED	H13 MMP C3 1003
				SUPER FINE SILVER	SM201 MMC 001

B No. 6173, 927th Fighter Regiment, Phúc Yên AB, Socialist Republic of Vietnam, 1979

As a compensation for destroyed MiG-21PFMs, the Vietnam Air Force received even this aircraft with a camouflage used in Soviet Air Force. Original marking of the aircraft was repainted and substituted by Vietnamese national insignia and a red number 6173. The reason for marking the nose of the aircraft by red stars is unclear. It could have meant the shot downs of enemy aircraft during the Vietnam War by Vietnamese pilots flying on specific planes. This aircraft operated from Bien Hoa base and Da Nang base, it was part of 372nd Air Division.

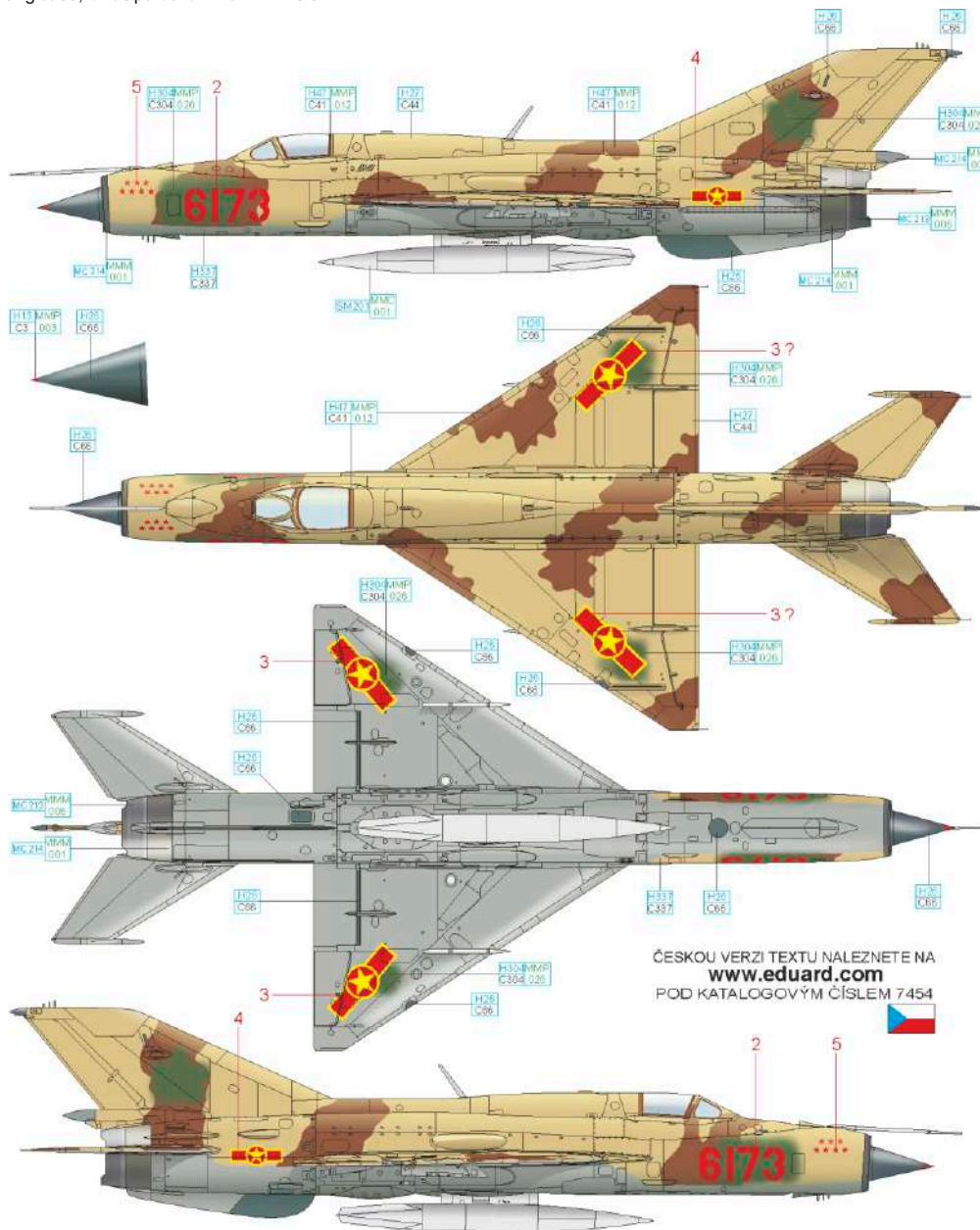

GRAY	H357 C337	GREEN	H30-MMP C304.026	STEEL	MC214 PMM 001
TAN	H26 C86	BROWN	H41-MMP C41.012	DARK IRON	MC214 PMM 001
				SUPER FINE SILVER	SM231 PMM 001
				GREEN	H26 C86
				RED	H113-MMP C11.033

FUSELAGE PYLON PODTRUPOVÝ PYLON

C40

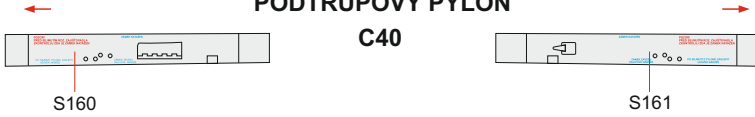

LEFT PYLON LEVÝ PYLON

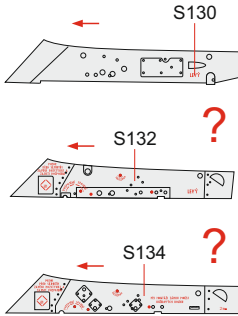

RIGHT PYLON PRAVÝ PYLON

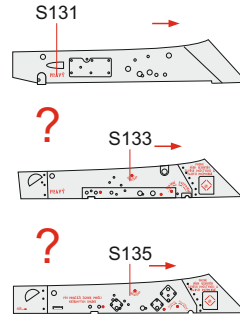

LEFT APU-7 LEVÉ APU-7

C38

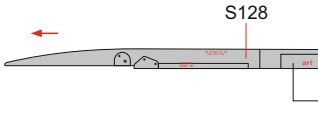

RIGHT APU-7 PRAVÉ APU-7

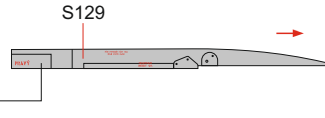

SM201
MMC
001

LEFT APU-13 LEVÉ APU-13

C5, C45



RIGHT APU-13 PRAVÉ APU-13



SM201
MMC
001

EXTERNAL FUEL TANK 800 I PŘÍDAVNÁ NÁDRŽ TANK 800 I

TOP

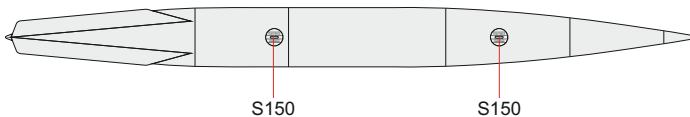

R-3S

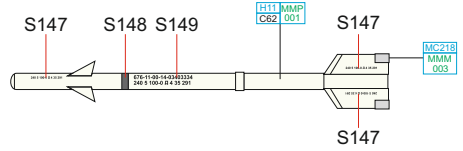
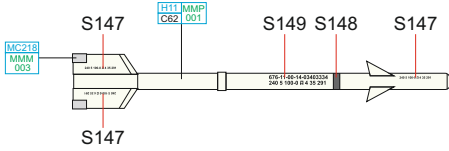

S-24

TOP

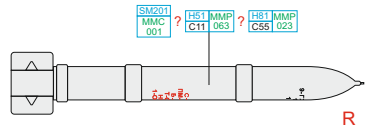
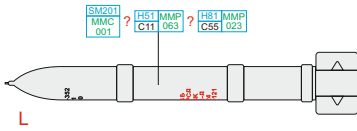
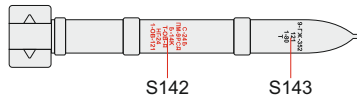

RS-2US

TOP

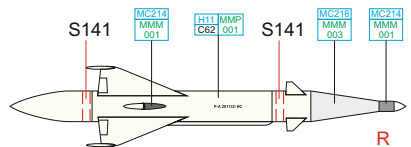
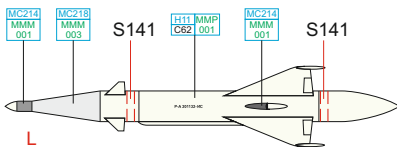
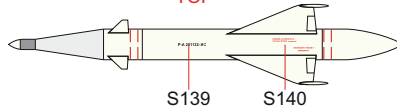

SN - SERIAL NUMBER

