

**ATTENTION - Useful advice!**

Stick the instructions carefully prior to assembly. Remove parts from frame with a sharp knife or a pair of scissors and trim away excess plastic. Do not put oil or parts. Assemble the parts in numerical sequence. Use plastic cement ONLY and use correct application to avoid damaging the model. Black arrows indicate parts to be glued together. White arrows indicate on which frame the parts must be assembled WITHOUT using cement. These letters (A, B, C...) indicate on which frame the parts will be found. Place small parts before detaching them from frame. Remove parts where parts are to be cemented. Crossed out parts must not be used.

**ATTENZIONE - Consigli utili!**

Prima di iniziare il montaggio studiate attentamente il disegno. Rimuovere con molta cura i pezzi dalle stampe, sarchiando un tagliola o forbici e togliere con una piccola lima o con carta vetrata l'eccesso di materiale. Non toccare i pezzi con le mani. Montare le parti nella sequenza numerata delle stampe. Eliminare dalla stampata il numero del pezzo appena montato facendo sopra una croce. Le frecce nere indicano i pezzi da montare le frecce bianche indicano i pezzi da montare senza colla. Usare solo colla per plastico. Le lettere (A, B, C...) ai lati dei numeri indicano la stampata ove si trova il pezzo da montare. I pezzi cancellati da una croce non sono da utilizzare.

**BEACHTUNG - Ein nützlicher Rat!**

Vor Montage die Zeichnung aufmerksam studieren. Die einzelnen Montageblätter mit einem Messer oder einer Schere vom Spritzblech sorgfältig entfernen. Eventuelle Grate werden mit einer Klinge oder feinem Schmirgelpapier beseitigt. Vermeiden Sie Montage mit den Händen anstellen. Bei der Montage die Teilenummerung befolgen. Platte zeigen die zu montierenden Teile während die weissen Pfeile die ohne Leim zu montierenden Teile anzeigen. Bitte nur Plastikklebstoff verwenden. Die Buchstaben (A, B, C...) neben den Nummern zeigen auf welchem Spritzblech der zu montierende Teil zu finden ist. Die mit einem Kreuz markierten Teile sind nicht zu verwenden.

**ATTENTION - Conseils utiles!**

Avant de commencer le montage, étudier attentivement le dessin. Détacher avec beaucoup de soin les morceaux du moule en saisi un massicot ou bien un pair de ciseaux et couper avec une petite lime avec de papier de verre les éventuels bavures. Éviter de toucher les pièces avec les mains. Monter les pièces dans l'ordre des numéros des stam. Éliminer de la moule le numéro de la pièce qui vient d'être montée, en le faisant avec une croix. Les flèches noires indiquent les pièces à coller les flèches blanches indiquent les pièces à monter sans colle. Employer seulement de la colle pour plastique. Les lettres (A, B, C...) aux côtés des numéros indiquent la moule où se trouve la pièce à monter. Les pièces marquées par une croix ne sont pas à utiliser.

**OPBELET - Belangrijke aanwijzingen!**

Voordat u begint met het monteren, moet u eerst onderzocht van het kader. Maak ze af met een scherp mes of kleine mesje. Verwijder daarna al het overbodige plastic en polijst de delen voorzichtig af. Gebruik alleen uw vingers voor het monteren. Wees zorgvuldig en spaarsam, want het zal uw model beschadigen. Zie de nummers naast de te lijmen delen op. Witte pijlen wijzen naar bouwonderdelen die niet geplakt worden. Zwarte pijlen duiden de te lijmen delen aan. Verwijder de letters (A, B, C...) naast de letters van de onderdelen die bevinden. Schilder de kleine onderdelen voor ze van het kader te slijden. Verwijder de letters die de lijmen aanduiden.

**ATENCIÓN - Consejos útiles!**

Antes de las instrucciones cuidadosamente antes de comenzar el montaje. Separe las piezas de las bandejas con un cuchillo afilado o un par de tijeras y retire el exceso de plástico o rebaba. No amasar las piezas. Montar las piezas en orden numérico. Utilizar SÓLOMENTE pegamento para plástico y en buena cantidad para evitar que se dañe el modelo. Las flechas negras indican las piezas que se deben pegar juntas. Las flechas blancas indican las piezas que deben ensamblarse SIN usar pegamento. Las letras (A, B, C...) indican en qué bandeja se encuentran las piezas. Prestar las piezas pequeñas antes de separarlas de la bandeja. Retirar el número de los números por donde se deben pegar las piezas.

- Aprire i fori  
Drehen  
Ouvrir les trous  
Die Locher ausformen  
Perforar los agujeros  
Open gaten
- Separare  
Cut  
Retirer  
Entfernen  
Separar  
Gescheiden

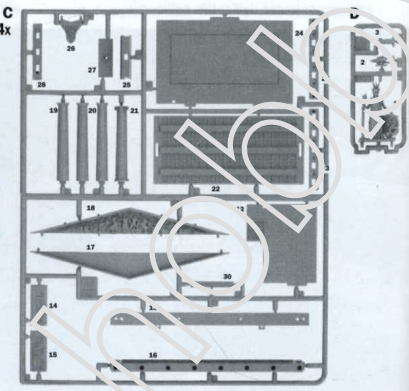
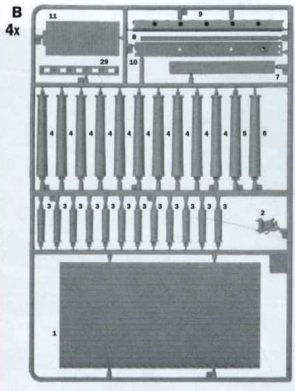
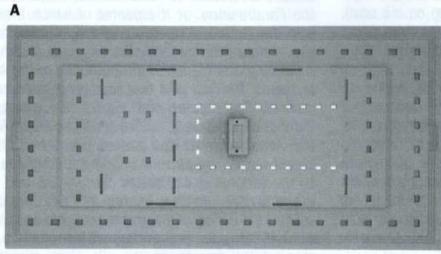

10

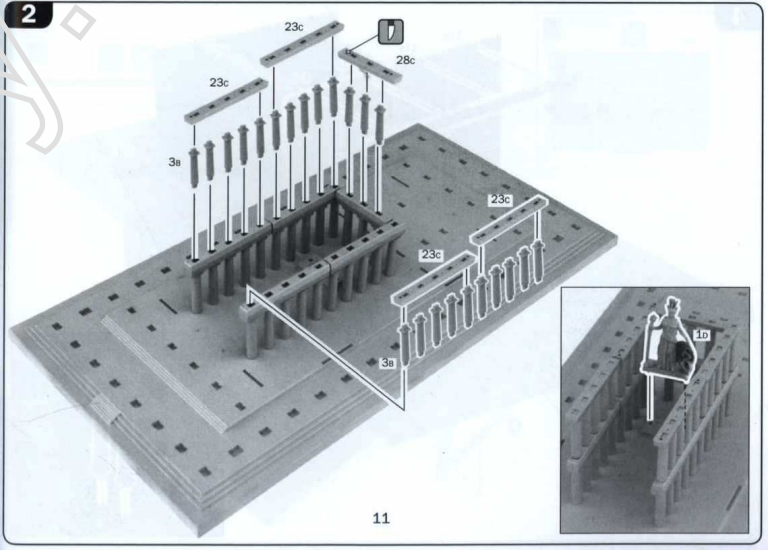
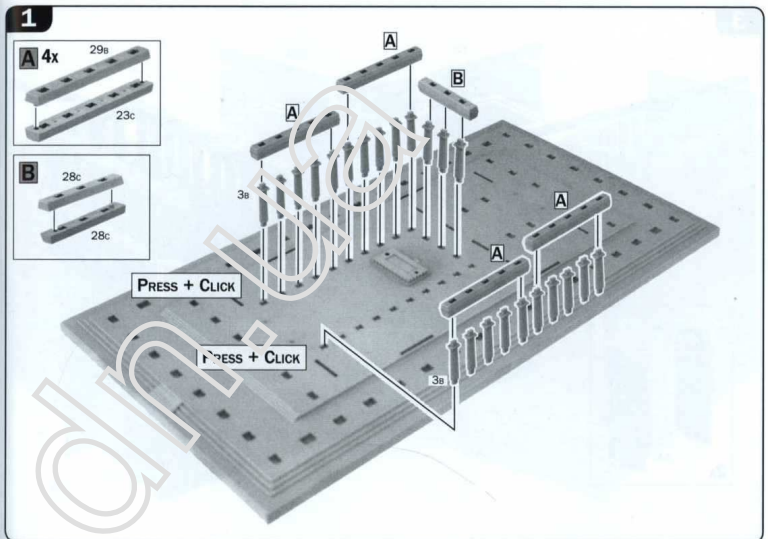

11

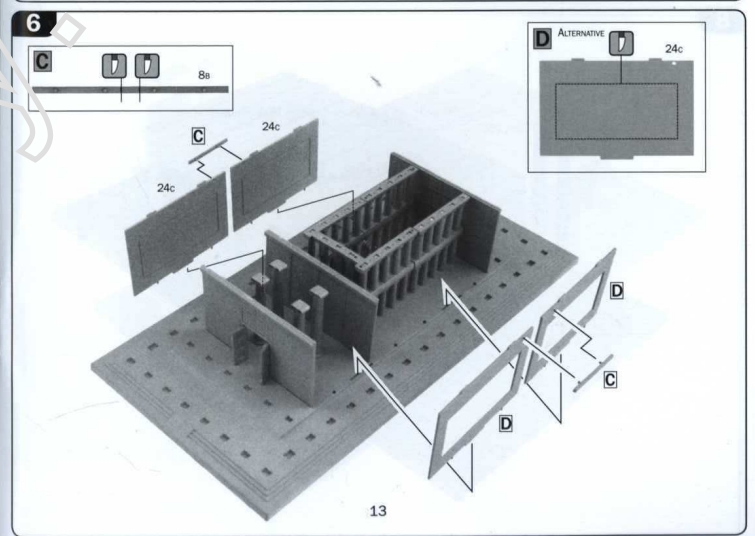
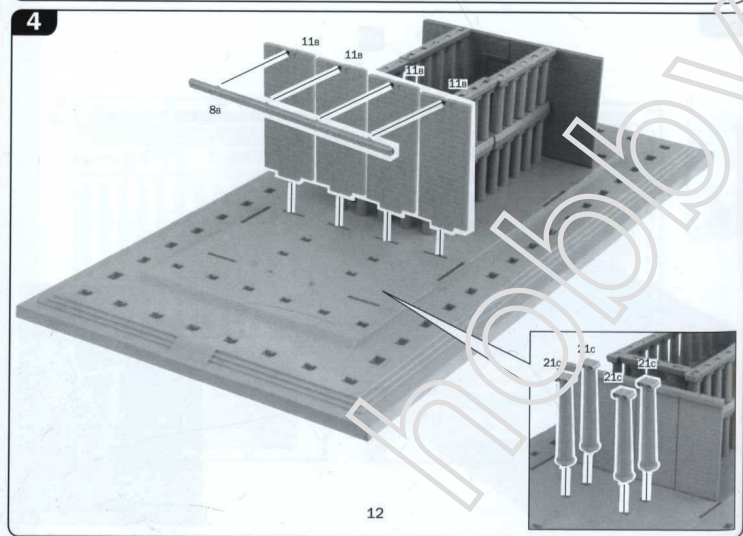
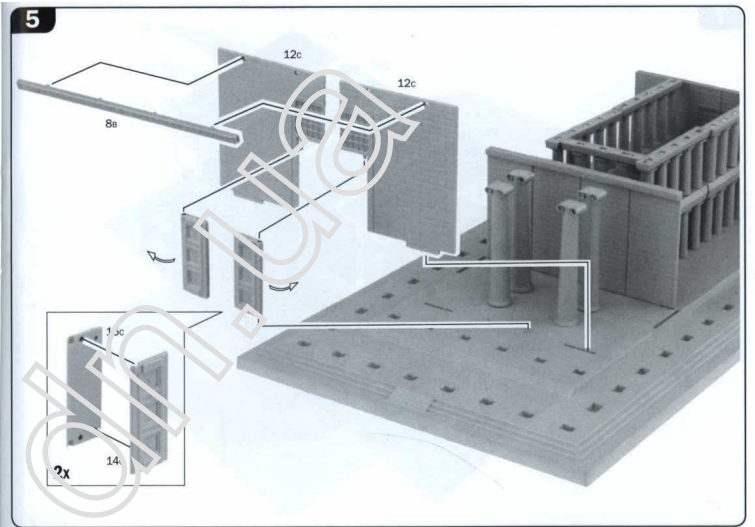
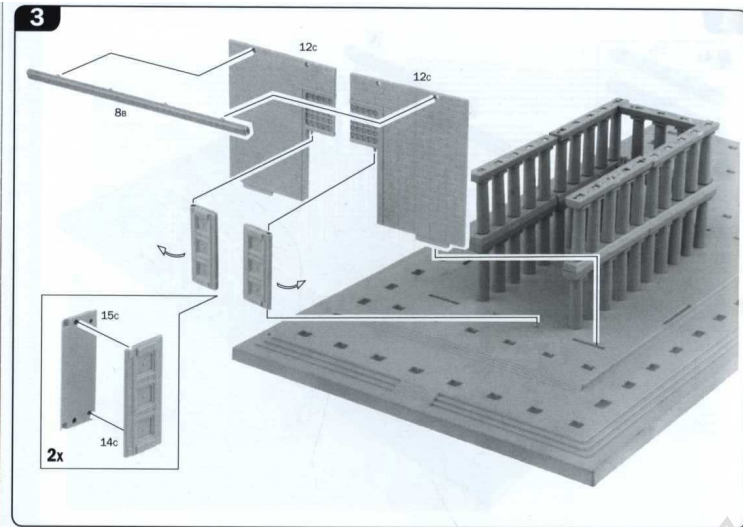

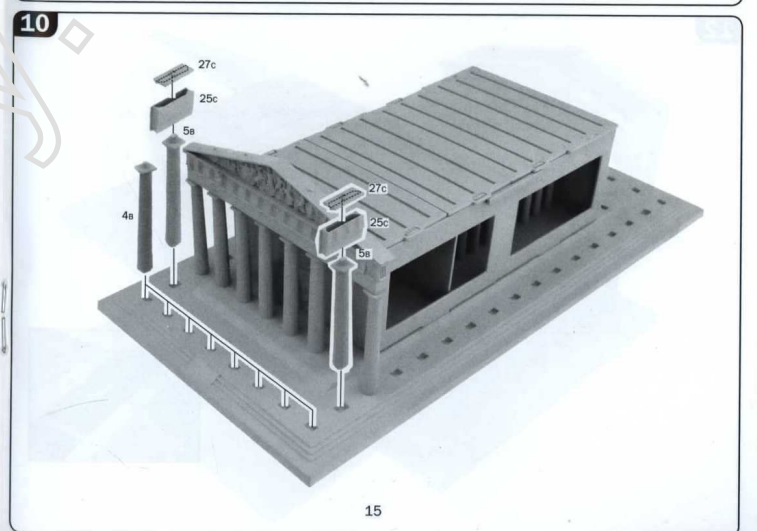
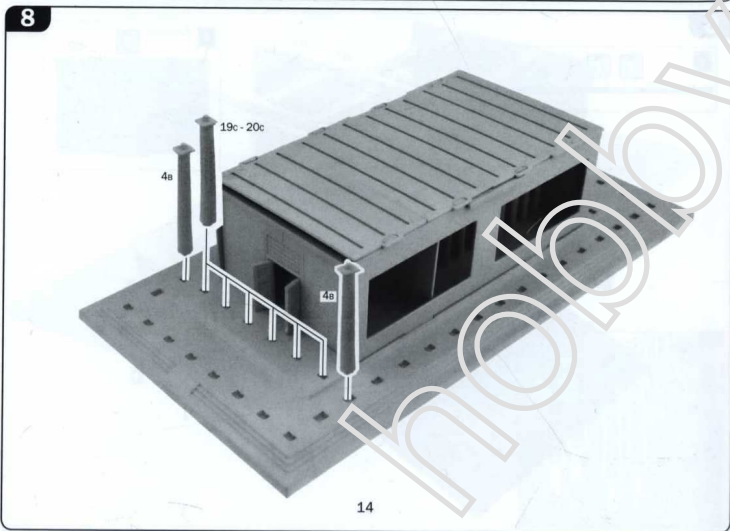
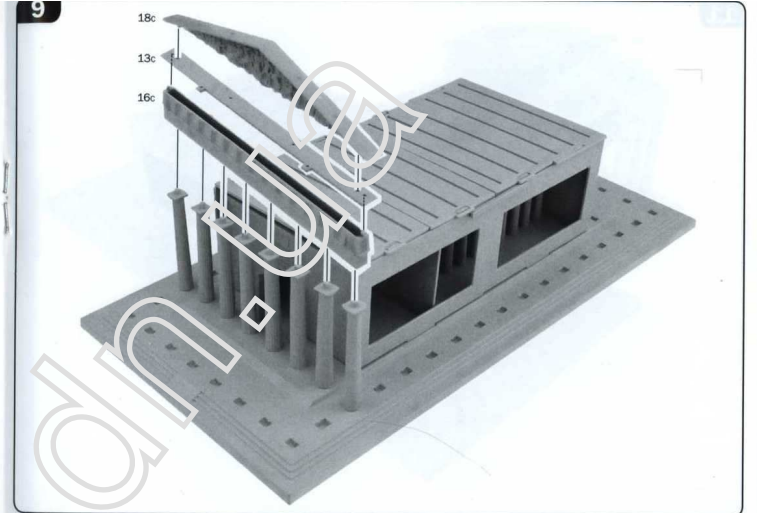
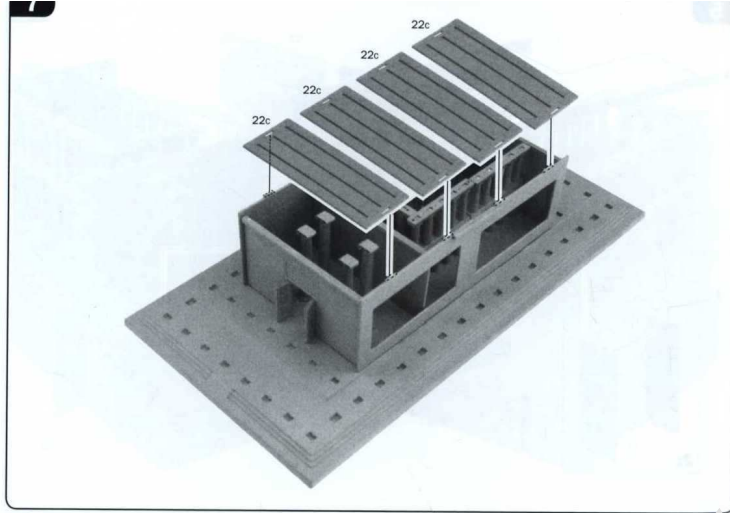

11

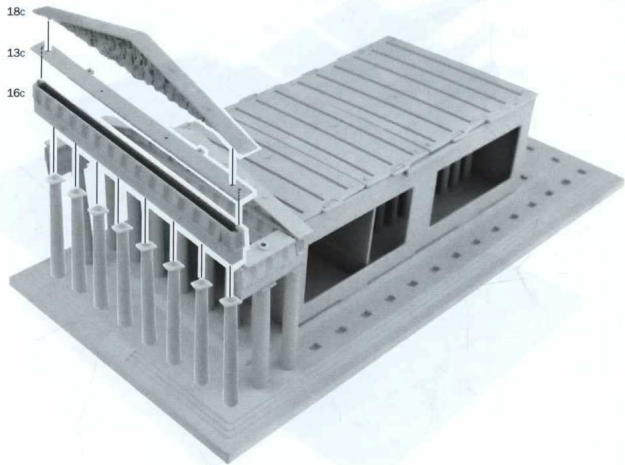

13

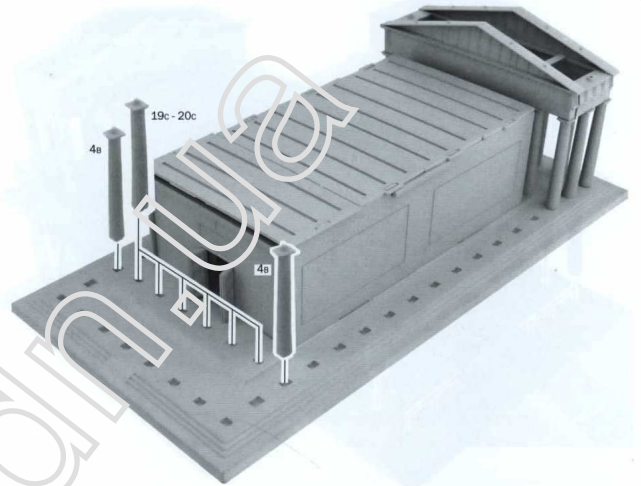

12

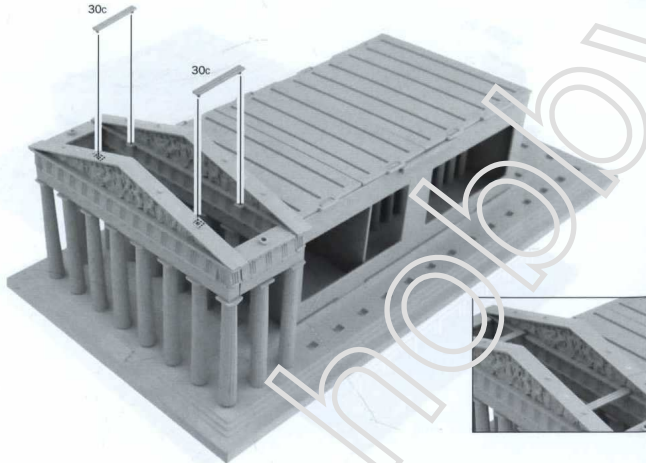

16

14

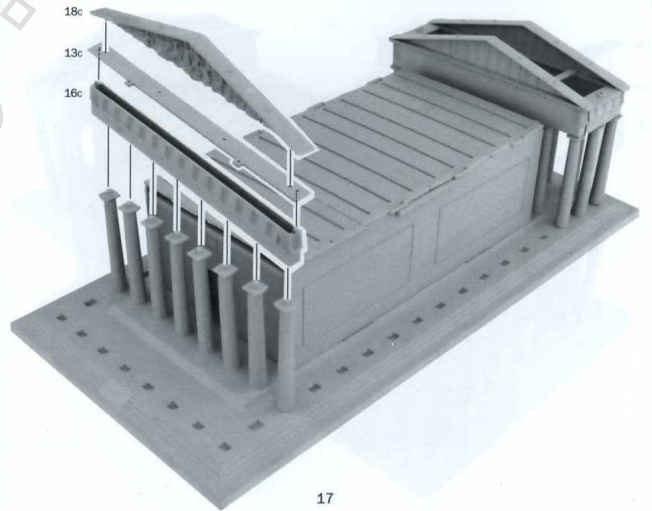

17

15

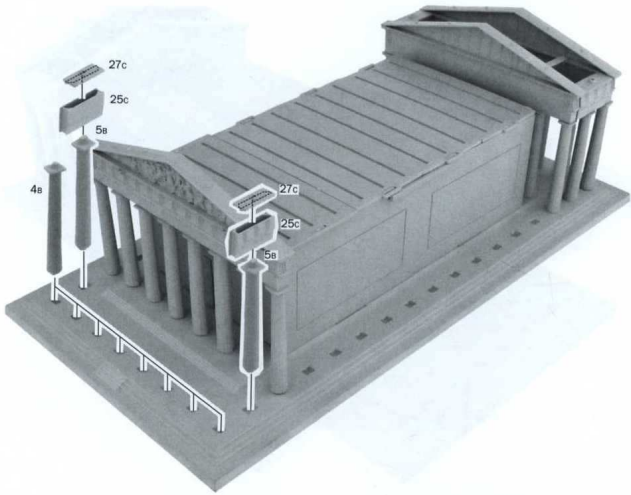

17

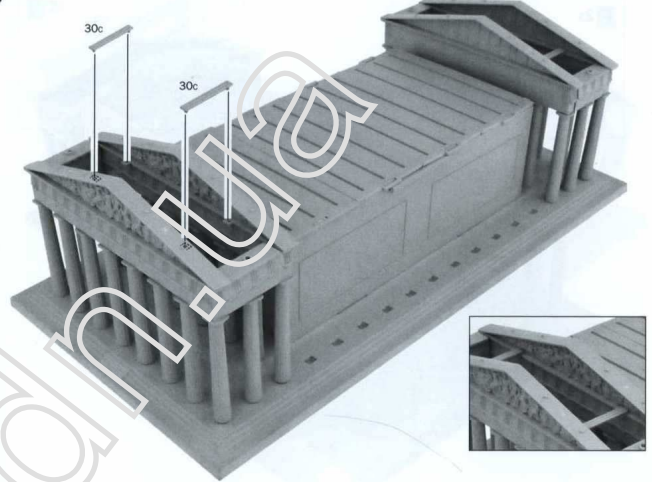

16

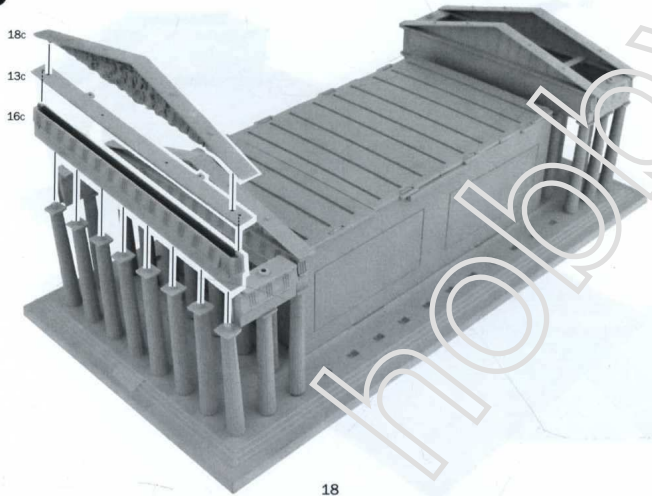

18

18

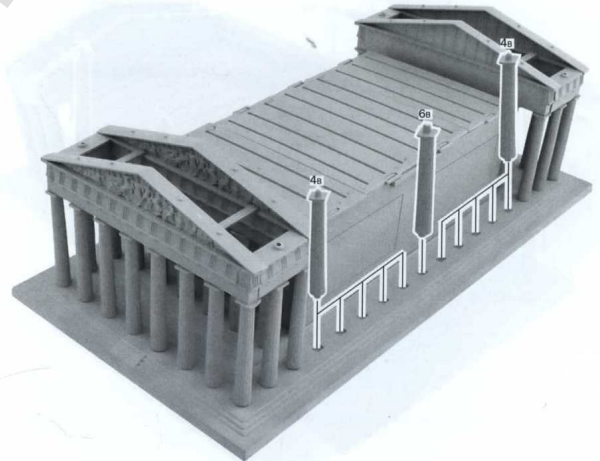

19

19

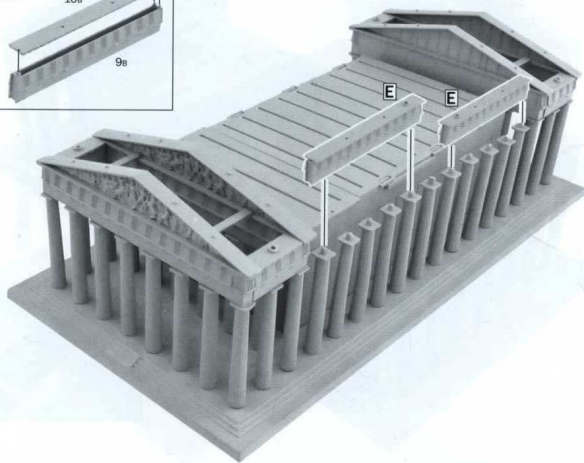
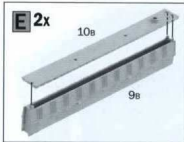

21

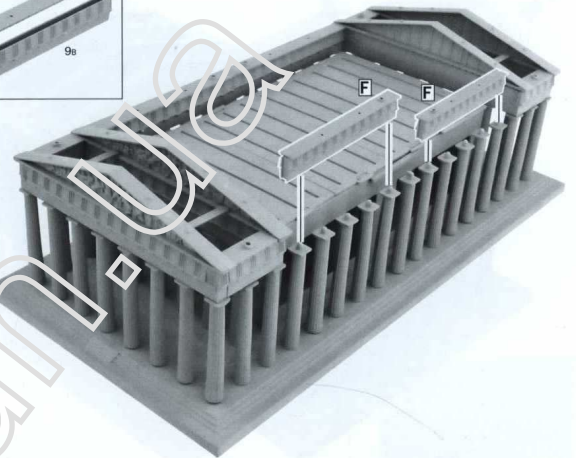
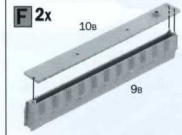

20

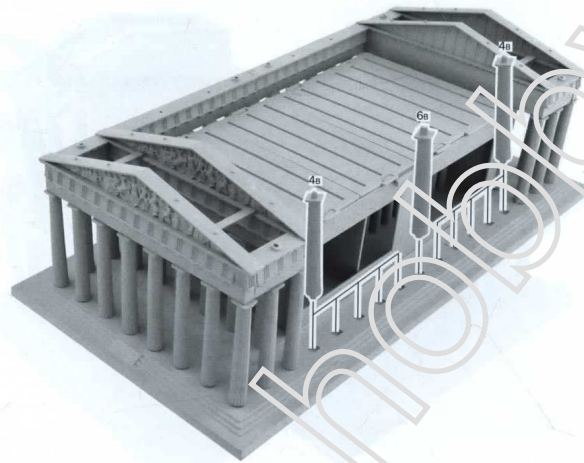

20

22

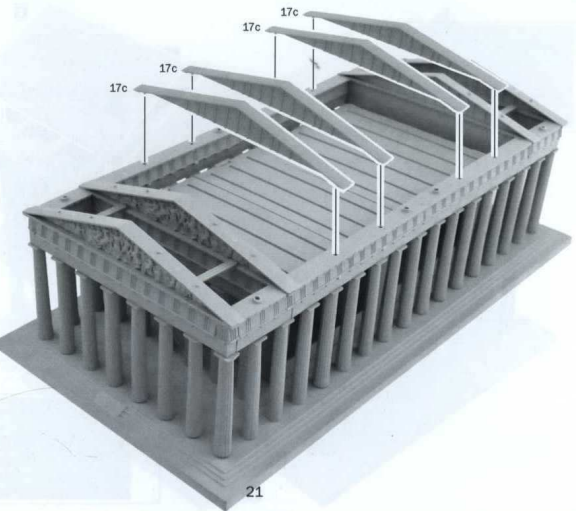

21

23

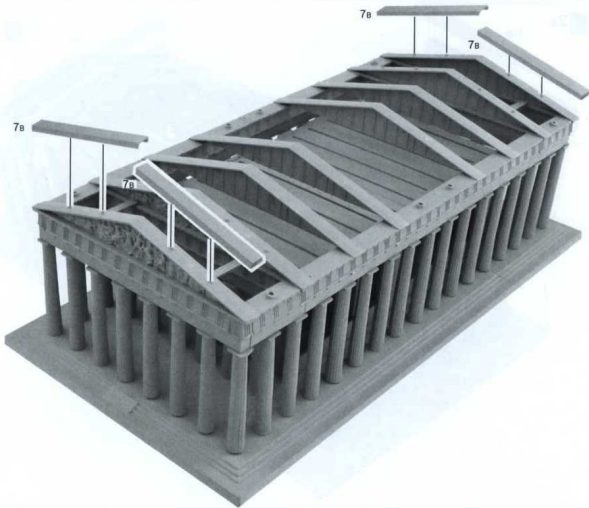

25

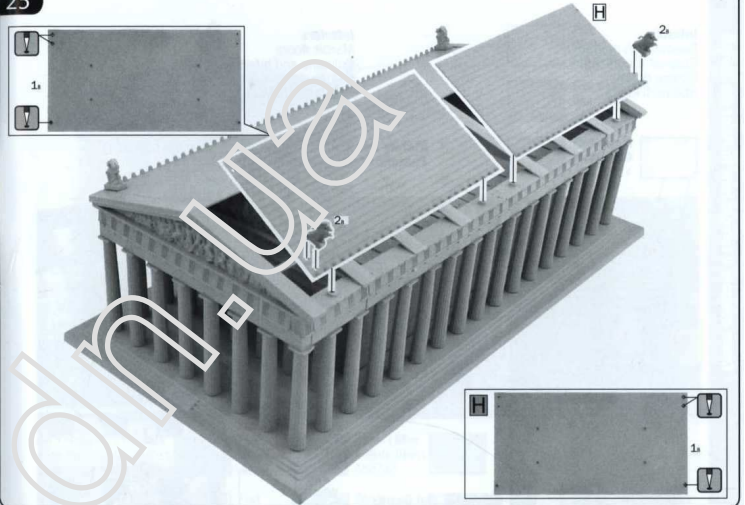

24

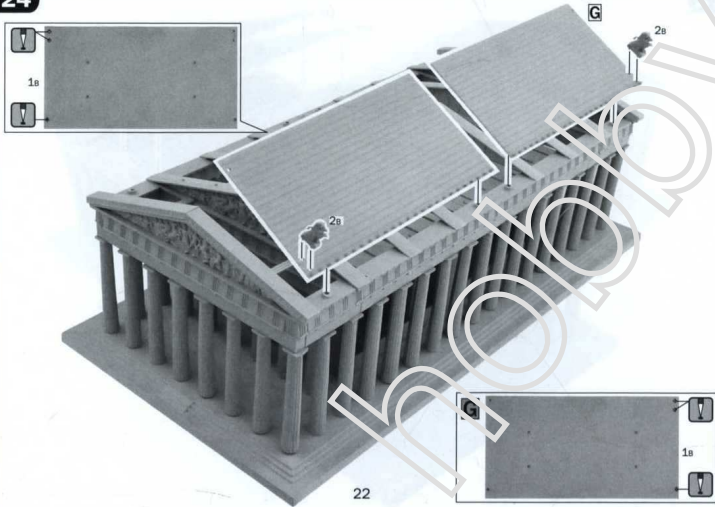

26

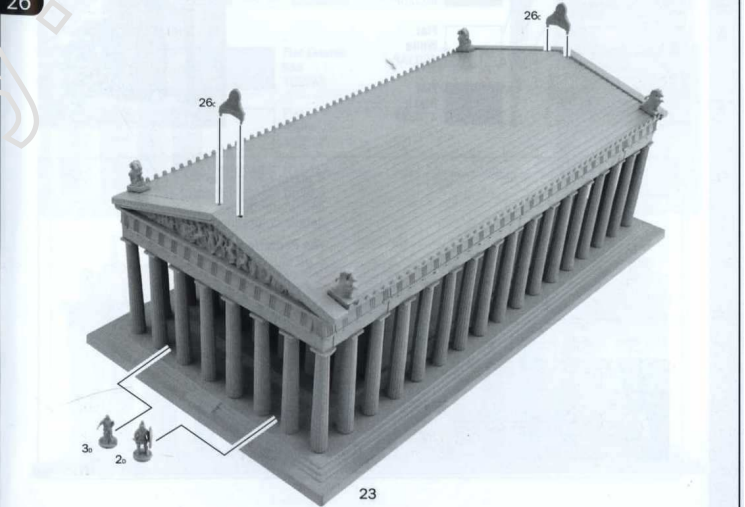

**Interni:**  
 Pavimenti in marmo,  
 Colonne e porticato  
 Portoni dorati  
 Statua di Atena

**Interiors**  
 Marble floors  
 Columns and internal arcade  
 Golden doors  
 Statue of Athena

**Metal Gloss Gold**  
 4671AP

**Marmo Pentelico** Colori di riferimento nella scheda  
**Pentelic Marble** Color Reference tab



**Il marmo Pentelico**  
 è di un bianco impeccabile  
 con una uniforme,  
 debole colorazione gialla.

**The Pentelic marble**  
 is an impeccable white  
 with uniform, very slight  
 yellow colour tint in

<b>Flat Skin tone Warm Tint</b> 4603AP
<b>Flat Light Flesh</b> 4769AP
<b>Flat White</b> 4603AP



**Il frontone orientale**  
 è occidentale

**The eastern and western pediments**  
 the colors you need







Flat White  
4603AP

Flat Guards Red  
4632AP

Gloss Light Blue  
4650AP

Flat Orange  
4603AP

Flat White  
4603AP



**Il tetto**  
Arancione  
mixato  
con una punta  
di bianco e  
ombreggiatura nera

**The roof**  
orange mixed  
with a tip  
of white and  
black shading



Flat Guards Red  
4632AP



Flat White  
4603AP

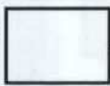

Flat Black  
4768AP

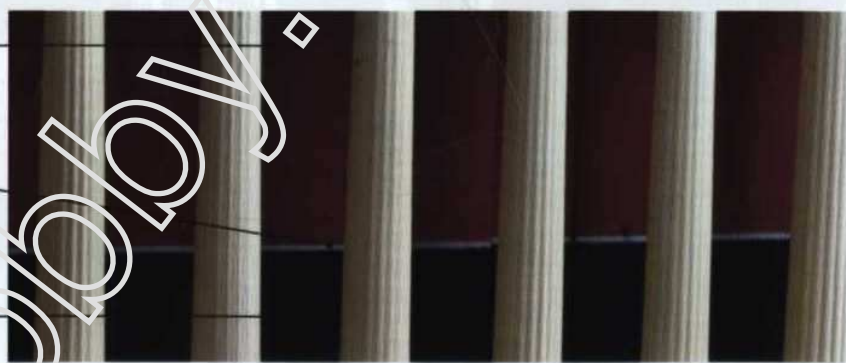

Usate le illustrazioni  
come riferimento  
per colorare le due  
figure esterne

Use illustrations  
as a reference  
for coloring the two  
external figures

