

GERMANY WWII V1 MISSILE LAUNCHING POSITION



ITEM NO: UA72033

The V-1 missile or V-1 flying bomb (German: Vergeltungswaffe 1 "Vengeance Weapon 1" also known to the Allies as the buzz bomb, or doodlebug, and in Germany as Kirschkern (cherrystone) or Maikäfer (maybug) —was an early cruise missile and the first production aircraft to use a pulsejet for power.)

The V-1 was developed at Peenemünde Army Research Center by the Nazi German Luftwaffe during the Second World War. During initial development it was known by the codename "Cherry Stone". The first of the so-called "Vengeance weapons" (V-weapons or Vergeltungswaffen) series designed for terror bombing of London — because of its limited range, the thousands of V-1 missiles launched into England were fired from launch facilities along the French (Pas-de-Calais) and Dutch coasts. The first V-1 was launched at London on 13 June 1944, one week after (and prompted by) the successful Allied landings in Europe. At its peak, more than one hundred V-1s a day were fired at south-east England, 9,521 in total, decreasing in number as sites were overrun until October 1944, when the last V-1 site in range of Britain was overrun by Allied forces. After this the V-1s were directed at the port of Antwerp and other targets in Belgium, with 2,448 V-1s being launched. The attacks stopped only a month before the war in Europe ended, when the last launch site in the Low Countries was overrun on 29 March 1945.

●READ BEFORE ASSEMBLY

1. When you use glue or paint, do not near flame, and use in a well-ventilated room.
2. Take extra care in handling photo etch parts in order to avoid injury.
3. When you take parts off the runner frame, use modelling scissors and trim excess plastic with a cutter or a file.
4. Glue and paint are not included.
5. This product is only suitable for experienced more than 14 years old.

●装配之前仔细阅读:

1. 勿於近火处使用胶水或油漆, 并 打开窗户保持空气流通。
2. 取蚀刻片时应特别注意安全, 防止利边划伤手指。
3. 从胶架上取出部件时, 应用模型专用剪, 并用界刀或小锉除去多余的胶料。
4. 请使用塑料胶水和油漆, 模型内不含。
5. 本产品不适合14岁以下没有经验的模型爱好者。

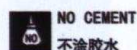
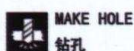

DECAL APPLICATION

1. Cut off decal from sheet.
2. Dip the decal in tepid water 40° C for about 10 sec. and place on a clean cloth.
3. Hold the backing sheet edge and slide decal onto the model.
4. Move decal into position by wetting decal with finger.
5. Press decal gently down with a soft cloth until excess water and air bubbles are gone.

水贴纸的使用:

1. 从水贴纸上剪下印花。
2. 将印花放入温水中浸10秒, 然后放在干净布上。
3. 拿着印花纸板将印花移到模型上。
4. 手指蘸水将印花移到适当的位置。
5. 用软布轻压印花直至不干, 气泡消失。

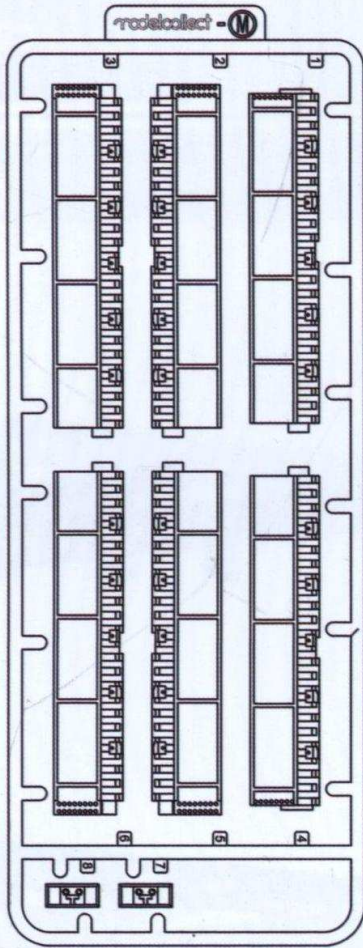

M x 4

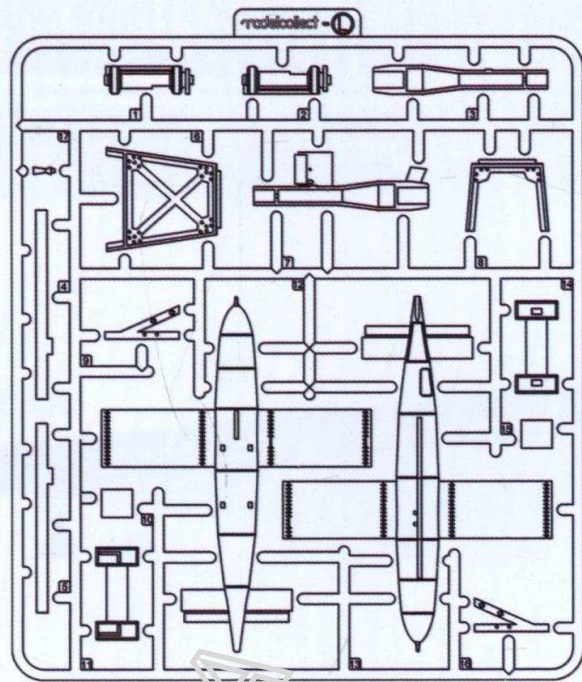

L x 2

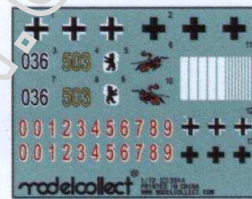

Decal

7 导弹组装1
Attaching missile 1

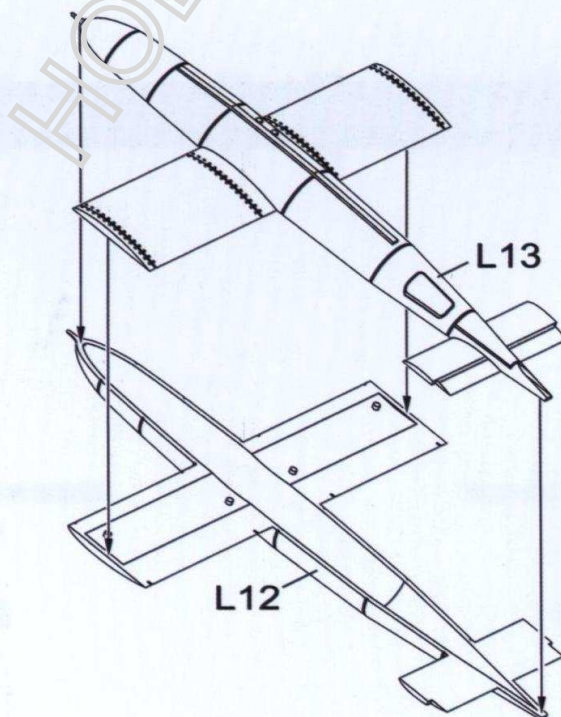

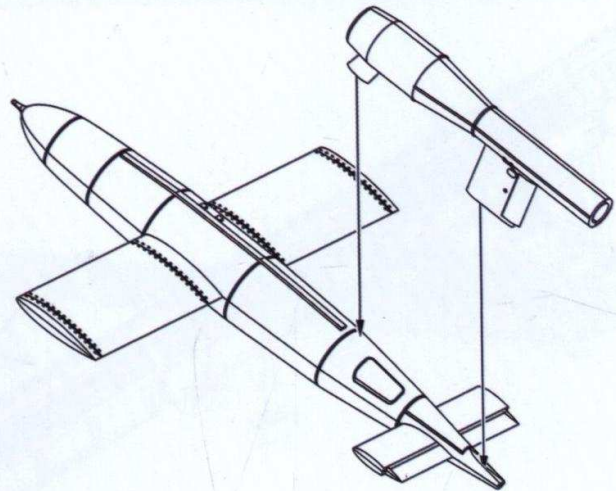
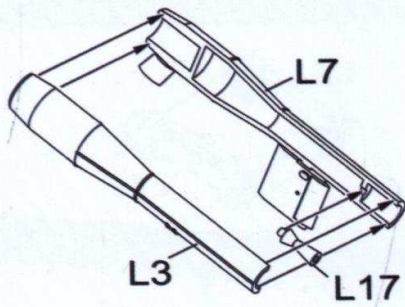

3

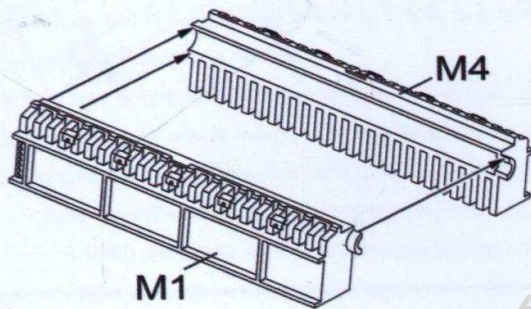

(V) x 4

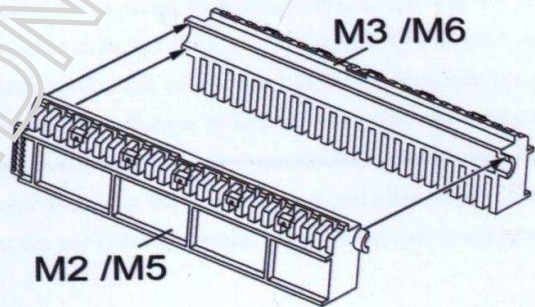

(T)

4

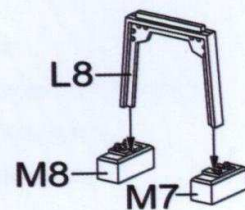
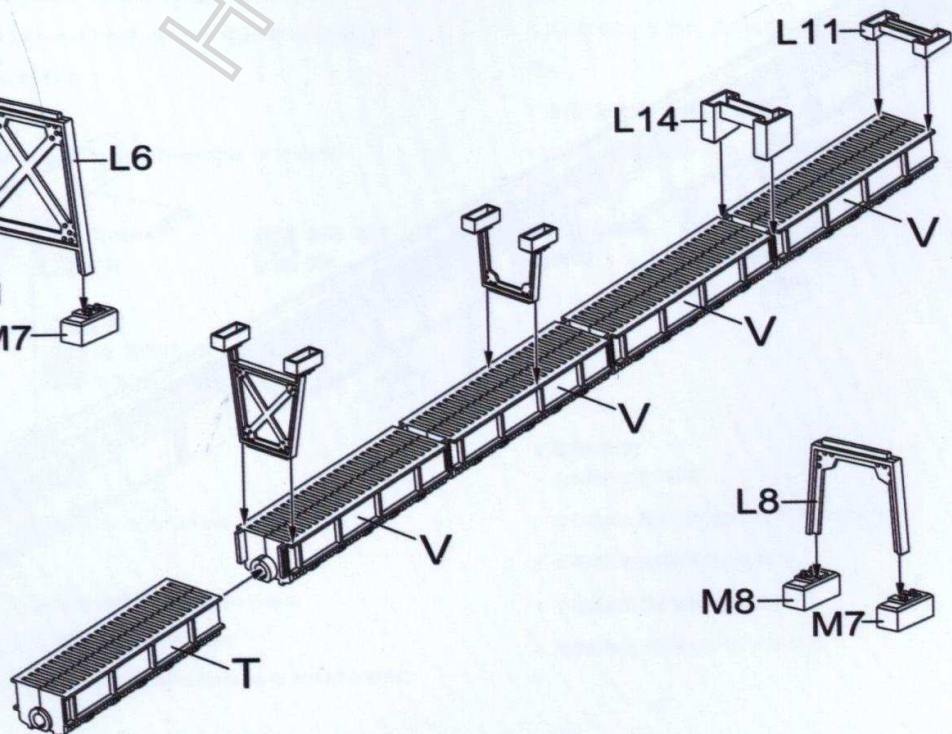
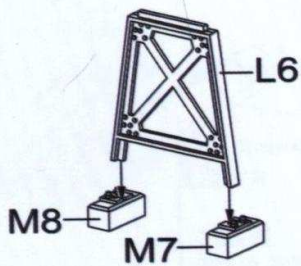

5

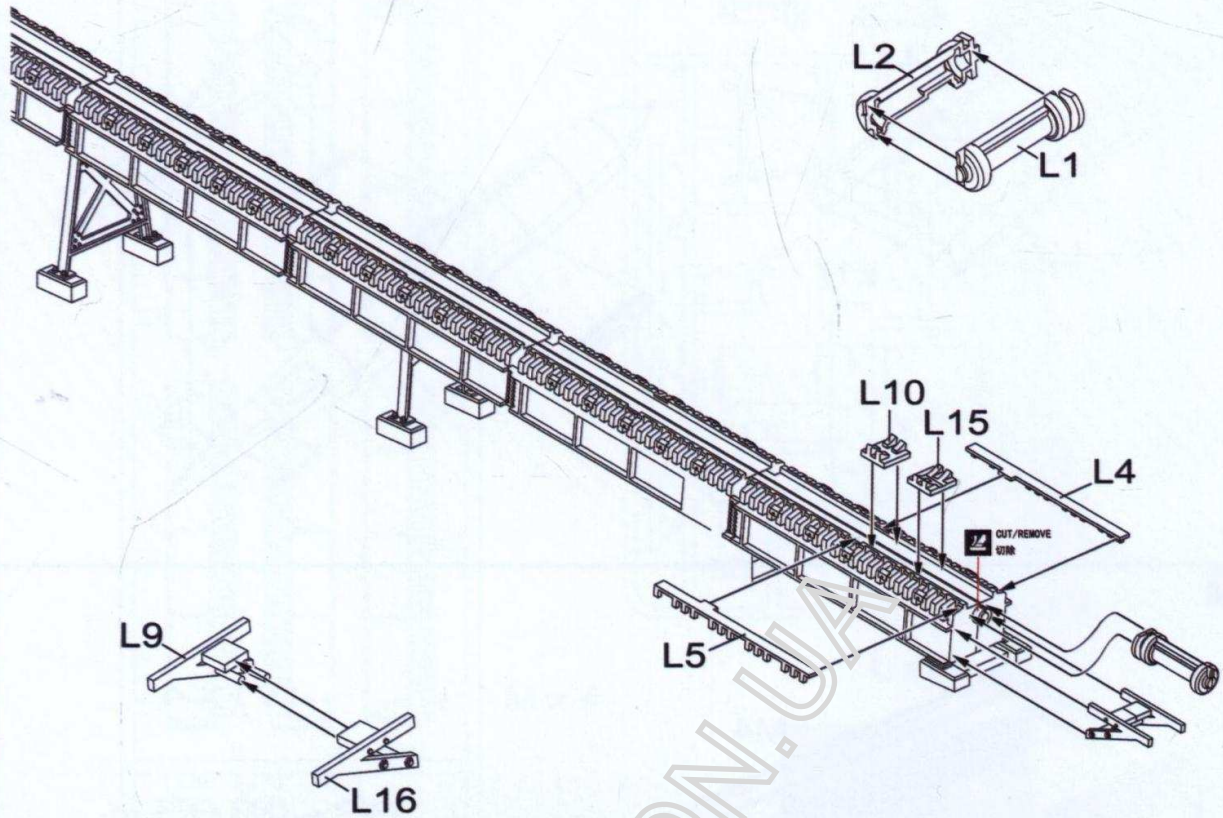

6

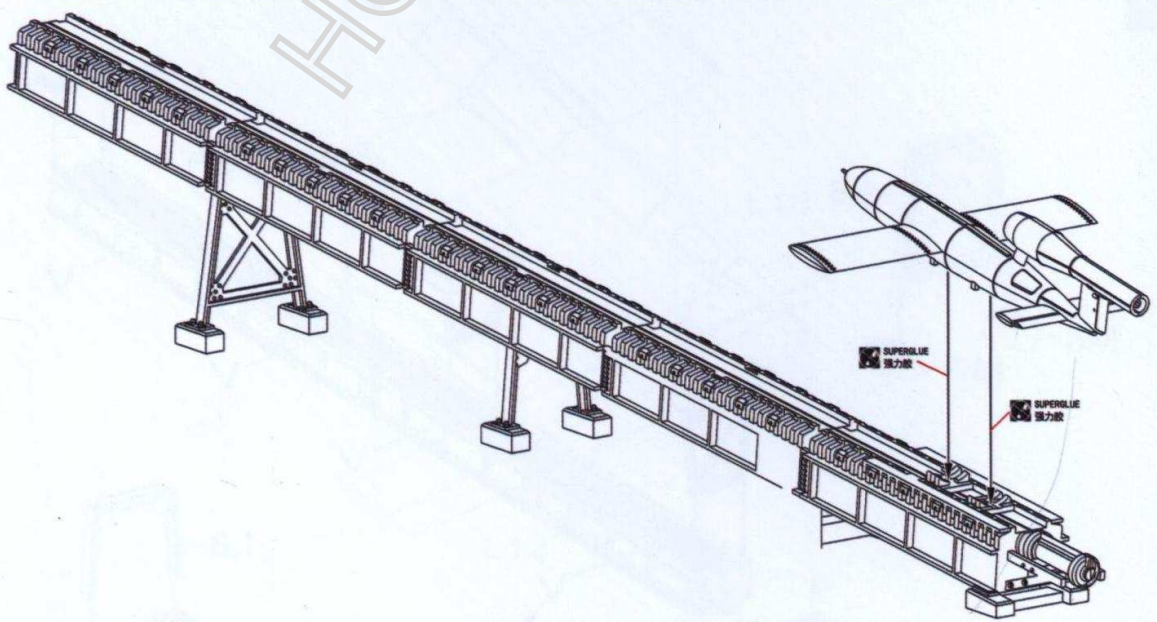

GEMANY WWII V1 MISSILE LAUNCHING POSITION



A.MIG 011	RAL 7028 DUNKELGELB AUS '44 DG I	A.MIG 003	RAL 8011 RESEDAGRÜN	A.MIG 008	RAL 7021 DUNKELGRAU	A.MIG 035	DARK TRACKS	A.MIG 037	NEW WOOD	A.MIG 911	GREY SHINE
A.MIG 014	RAL 8012 ROTBRAUN	A.MIG 230	82 GREEN	A.MIG 042	OLD RUST	A.MIG 046	MATT BLACK	A.MIG 063	PALE GREY		

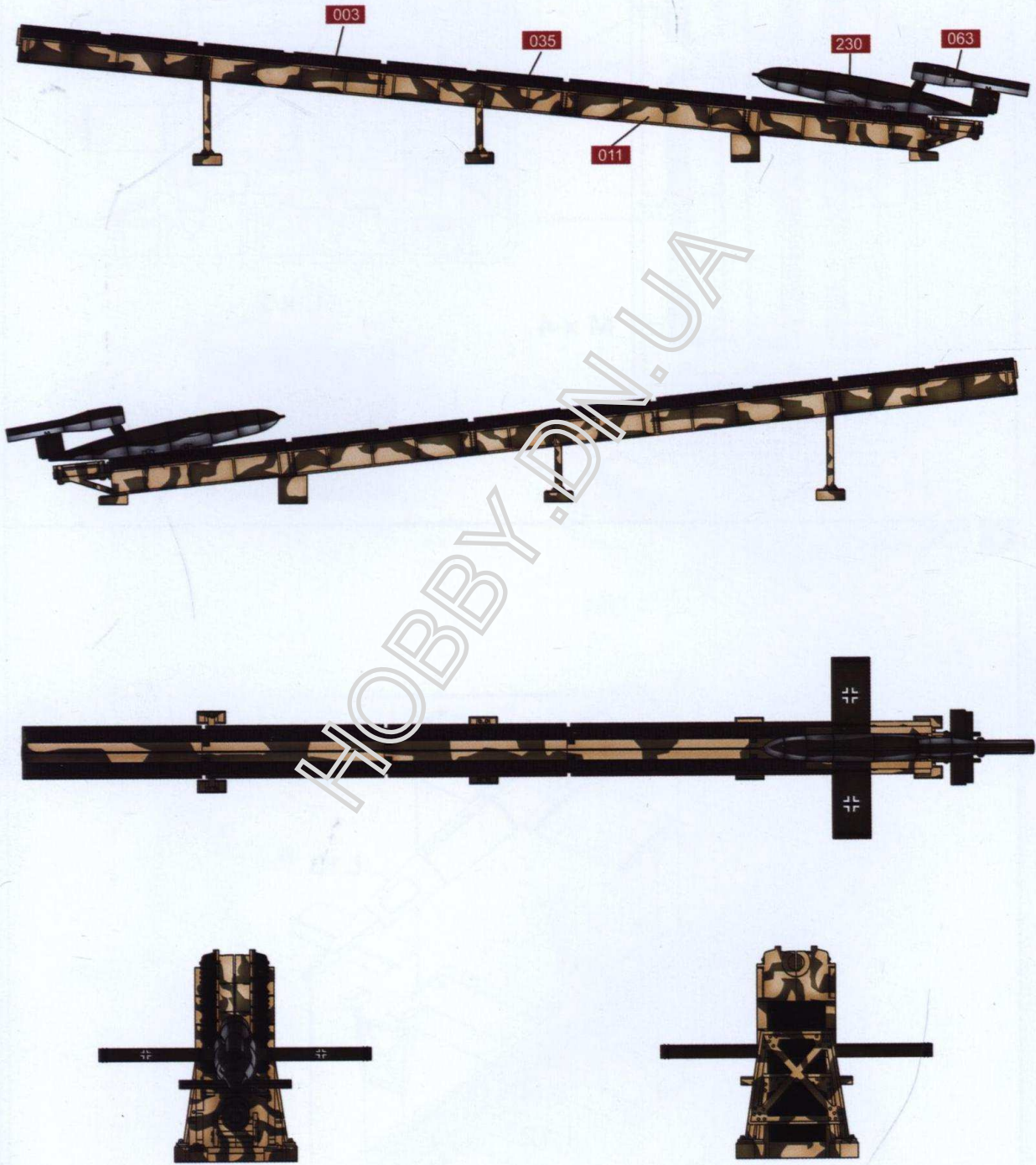

HOBBY.DN.UA



GEMANY WWII V1 MISSILE LAUNCHING POSITION



A.MIG 011	RAL 7028 DUNKELGELB AUS '44 DG I	A.MIG 230	82 GREEN	A.MIG 008	RAL 7021 DUNKELGRAU	A.MIG 035	DARK TRACKS	A.MIG 037	NEW WOOD	A.MIG 911	GREY SHINE
A.MIG 014	RAL 8012 ROTBRAUN	A.MIG 218	RLM 68 SCHWARTZGRAU	A.MIG 042	OLD RUST	A.MIG 046	MATT BLACK	A.MIG 063	PALE GREY		

