

SAAB J29 B

"22 U.N. FIGHTER SQUADRON"



SAAB 29 Flying Barrel, was a Swedish single-engine jet-powered fighter aircraft developed by Svenska Aeroplan Aktiebolaget (SAAB) on order from the Swedish Air Force and flew for the first time September 1st 1948. The aircraft was in active military service in Sweden and Austria between 1951 to early 1970s. The J29 was considered on a par with the contemporary American F-86 Saber and the Soviet MiG-15. SAAB 29 was in service in versions A, B, C, E & F, where version F had a more powerful engine with afterburner.

On May 6, 1954, Captain Anders Westerlund set a world record with a J29 B with an average speed of 977 km / h on a 500 km long track. The time was 30 minutes and 42 seconds. This distanced the previous American record by 27 km / h.

The Congolese crisis and the 22nd U.N. Fighter Squadron (F 22 wing in Congo)

The Congo crisis was a period of power struggles and severe unrest in Congo that began when Congo was declared independent from Belgium. Following a request from the UN on September 23, 1961, the Swedish government decided that a smaller group J29 B should be sent to the U.N. Fighter Wing, called F 22.

F 22 task was to protect UN air transport primarily through escorts and offensive missions, a task that offered great practical difficulties in the type of war waged in Congo in 1961. The difficulties of distinguishing between military targets and civilian facilities were extraordinarily great. On December 6, 1961, the first attack missions were carried out against the Kolwezi and Jadotville air bases in Katanga. The F 22's operation with the J29 B together with Indian Canberra aircraft and Iranian and a Philippine group with F-86 Sabers were at this time of crucial importance for the UN troops' security and success in Congo.

Its significant contribution was the attack on the air base at Kolwezi, where Katanga's air force was quick and surprisingly completely destroyed on the ground.

F 22 was disbanded in April 1963. Two J 29s and two S 29s were flown home to Sweden, other aircrafts were blown up on the spot because the cost of flying them home was considered too expensive as they would not be needed for the Swedish war organization. A total of 9 J29 B and 2 S29 C served in Congo.



Plastic kit no. 48-A004

©2020 P Replicas Sweden



How to read the instructions.

Plastic part number → **1 1** ← Recommended color

Remember that the colors of the aircraft are depending on age and wear. These color recommendations gives the builder an idea about the level of tint. It is important to have a gloss or semi-gloss surface to get the best result when applying the decals. Apply another coat of appropriate varnish after decal application.

Please visit www.pilot-replicas.com or our facebook page [pilot-replicas](https://www.facebook.com/pilot-replicas) for reference pictures.

Pilot replica color code	Color	Tamiya	FS95	Humbrol	Vallejo
1	Dark Green	XF-26	34092	30	71.124
2	Green	X-26	34128	163	71.014
3	Black	XF-1		33	71.057
4	Black Green	XF-27	34064	91	71.019
5	Silver	X-11		11	71.064
6	Aluminium	XF-16		27001	77.716
7	Gunmetal	X-10		27004	77.721
8	Green			131	70.346
9	Red	X-7		19	71.003
10	Tan	XF-55	36555	237	71.075
11	Gray		36270	127	71.050
12	Yellow lazure		13618		71.106

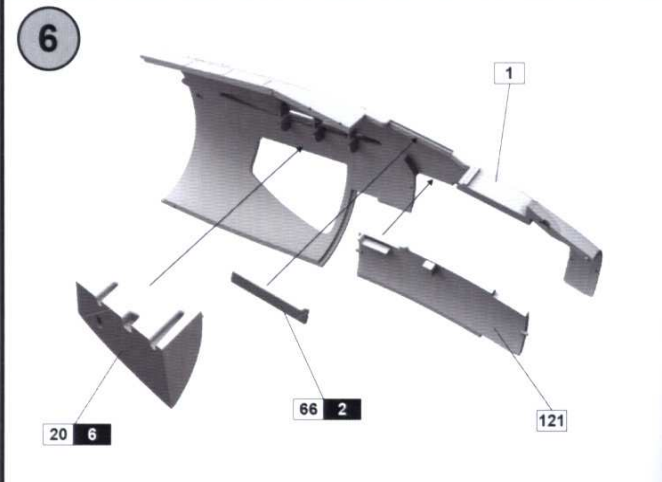
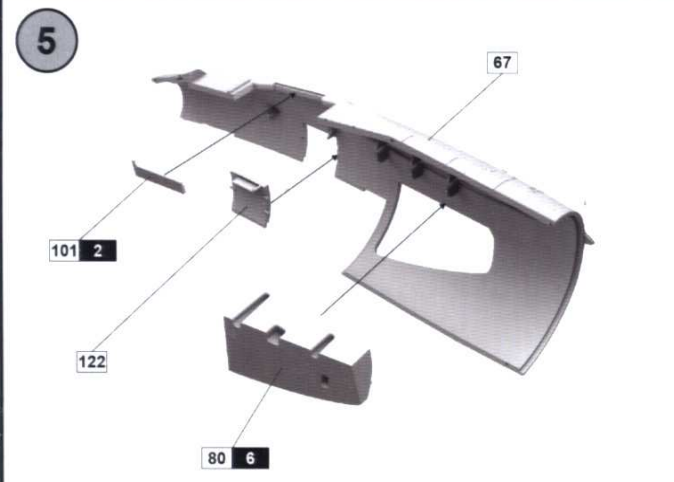
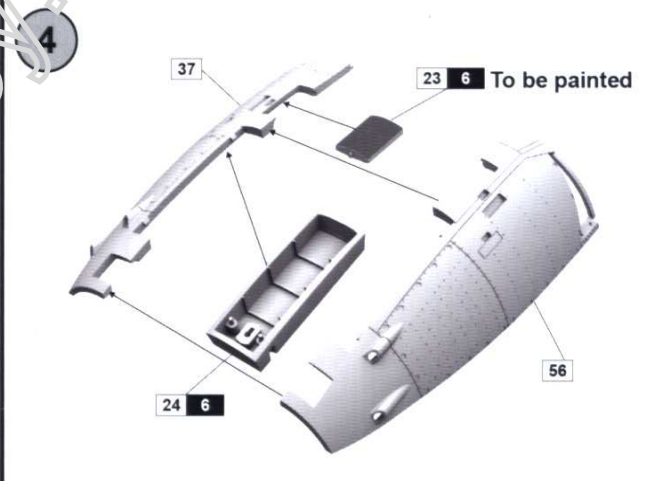
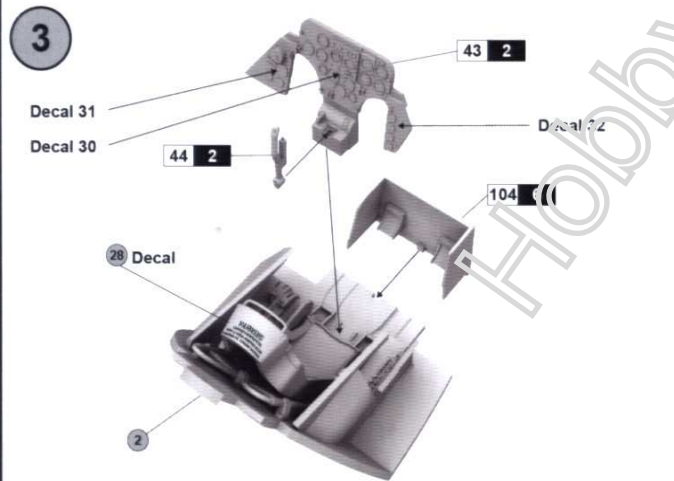
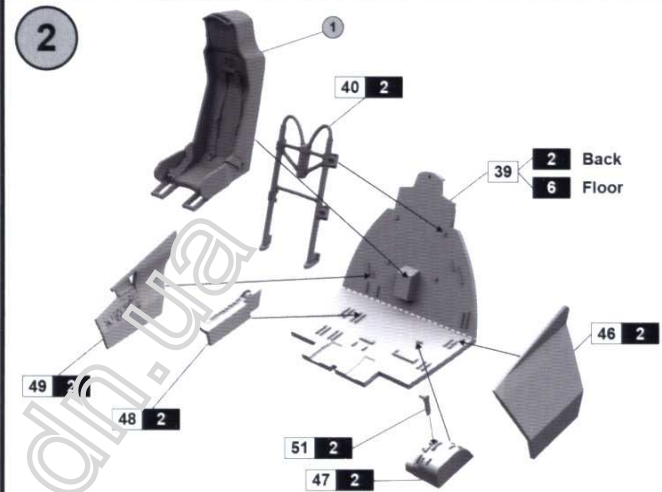
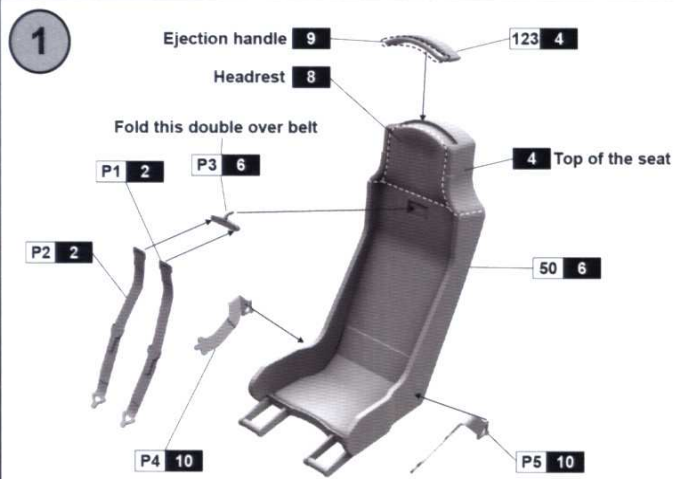

7

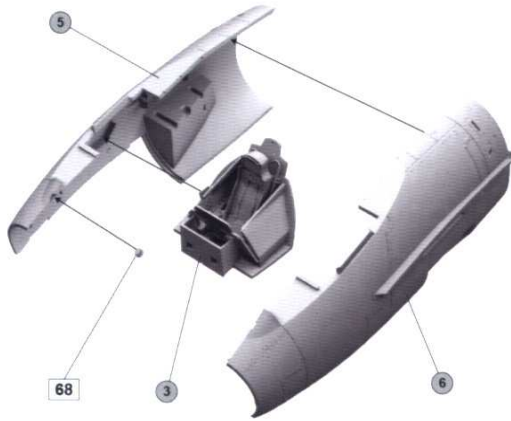

8

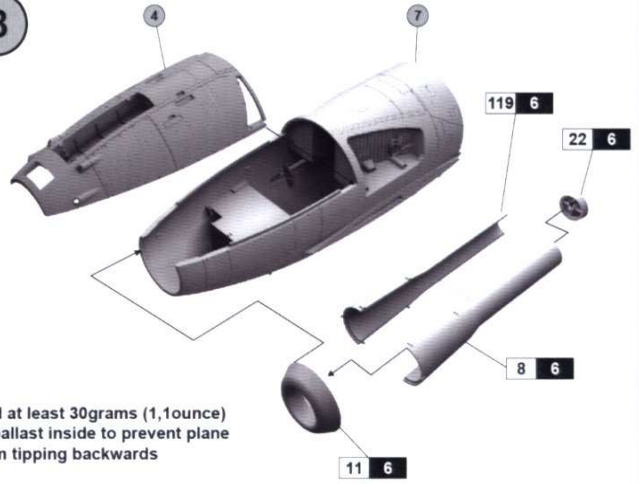

Add at least 30grams (1,1ounce) of ballast inside to prevent plane from tipping backwards

9

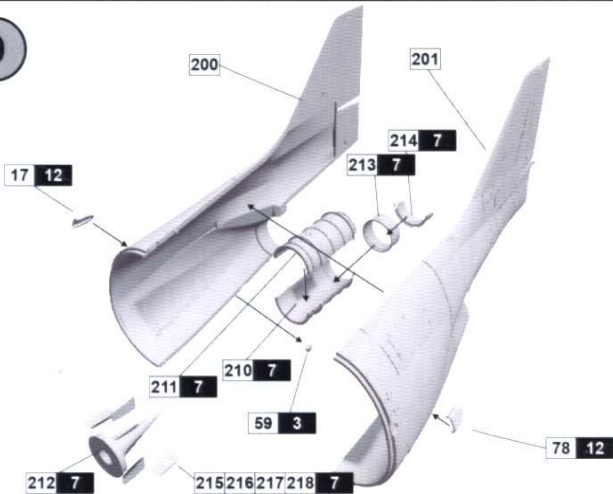

10



11

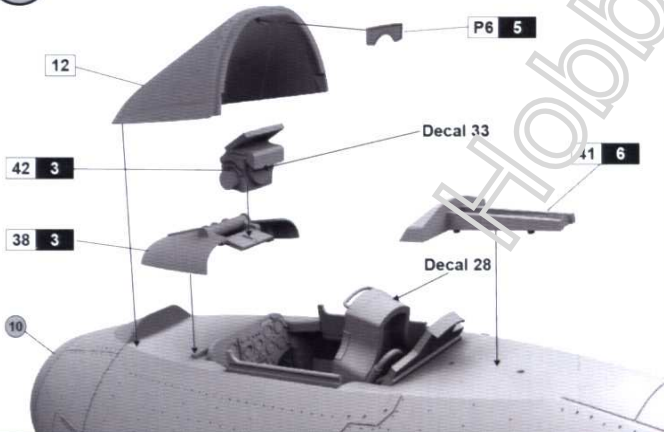

12

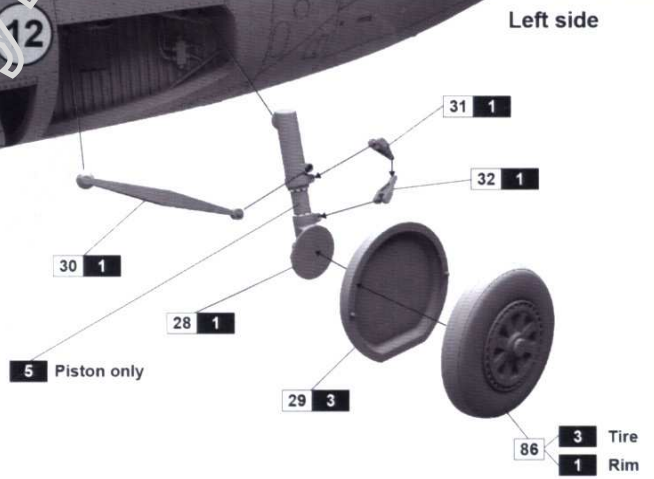

13

Right side

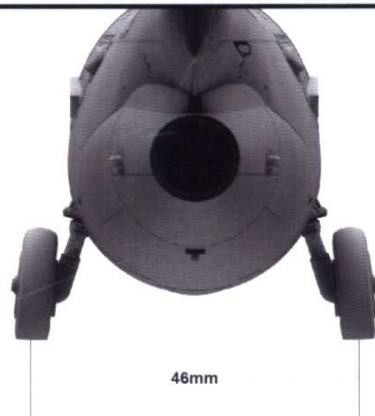

46mm

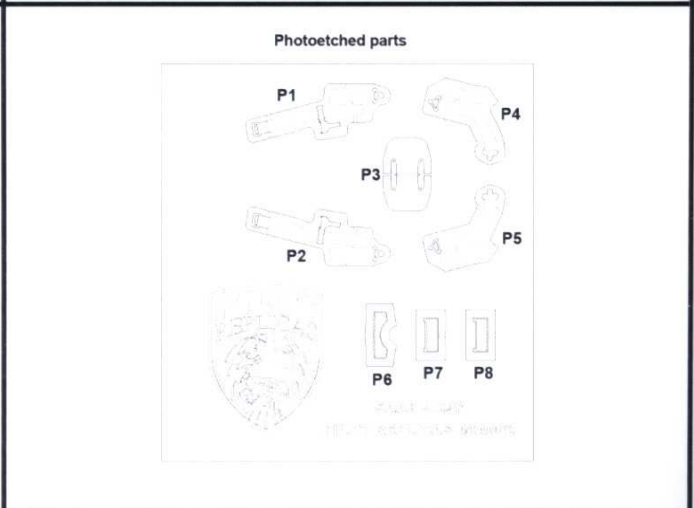
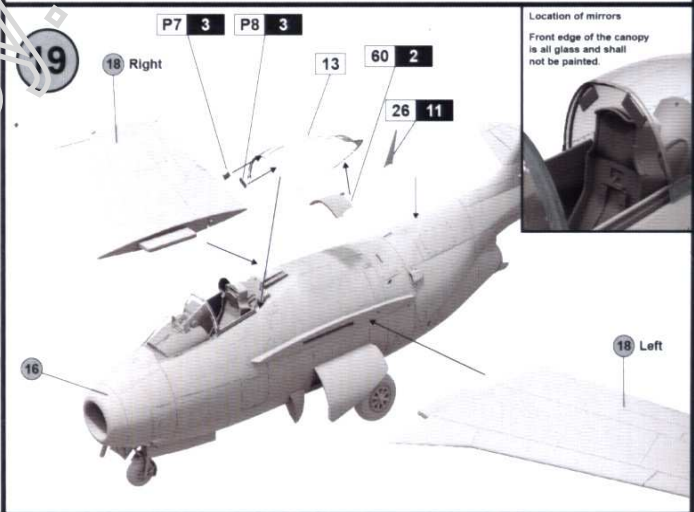
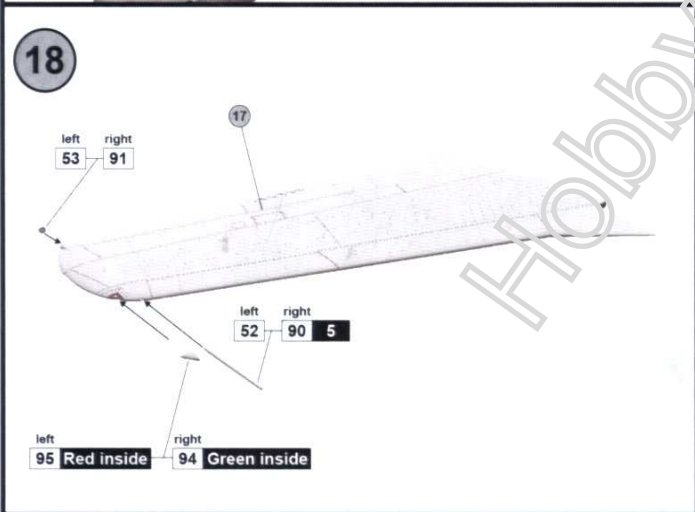
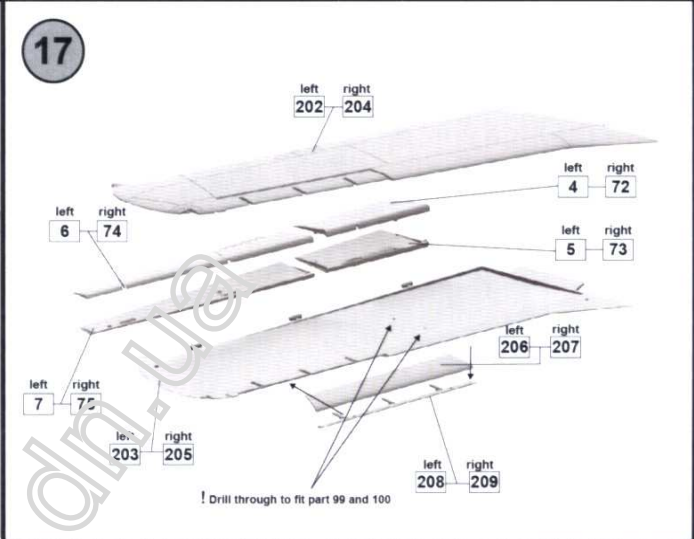
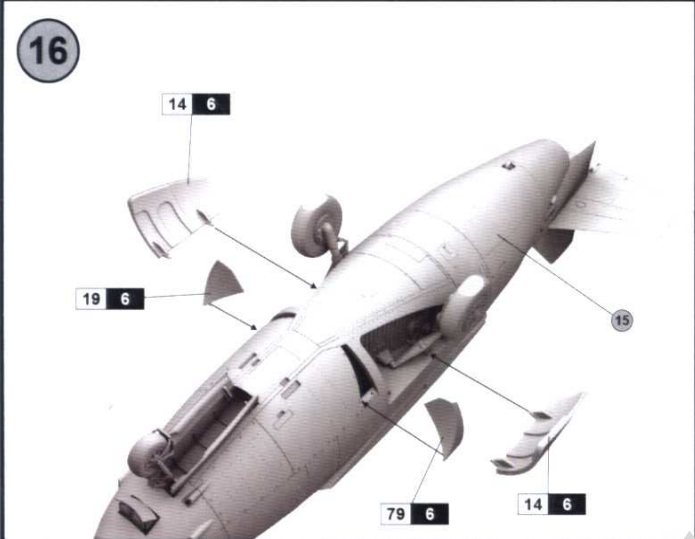
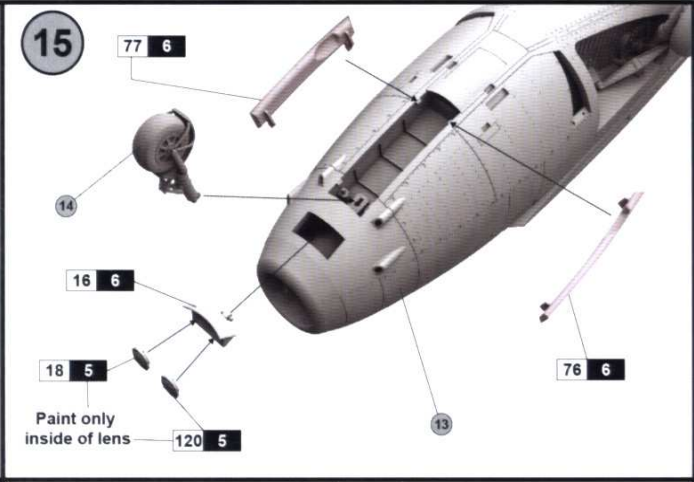
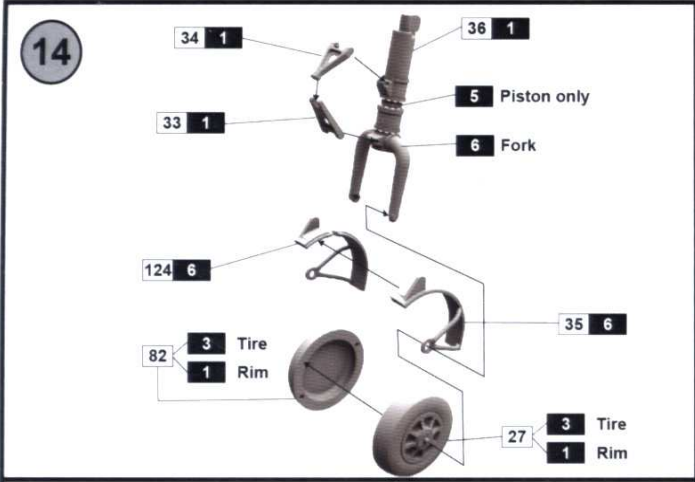



SAAB J29 B

COLORS AND MARKINGS

1:48 scale premium series

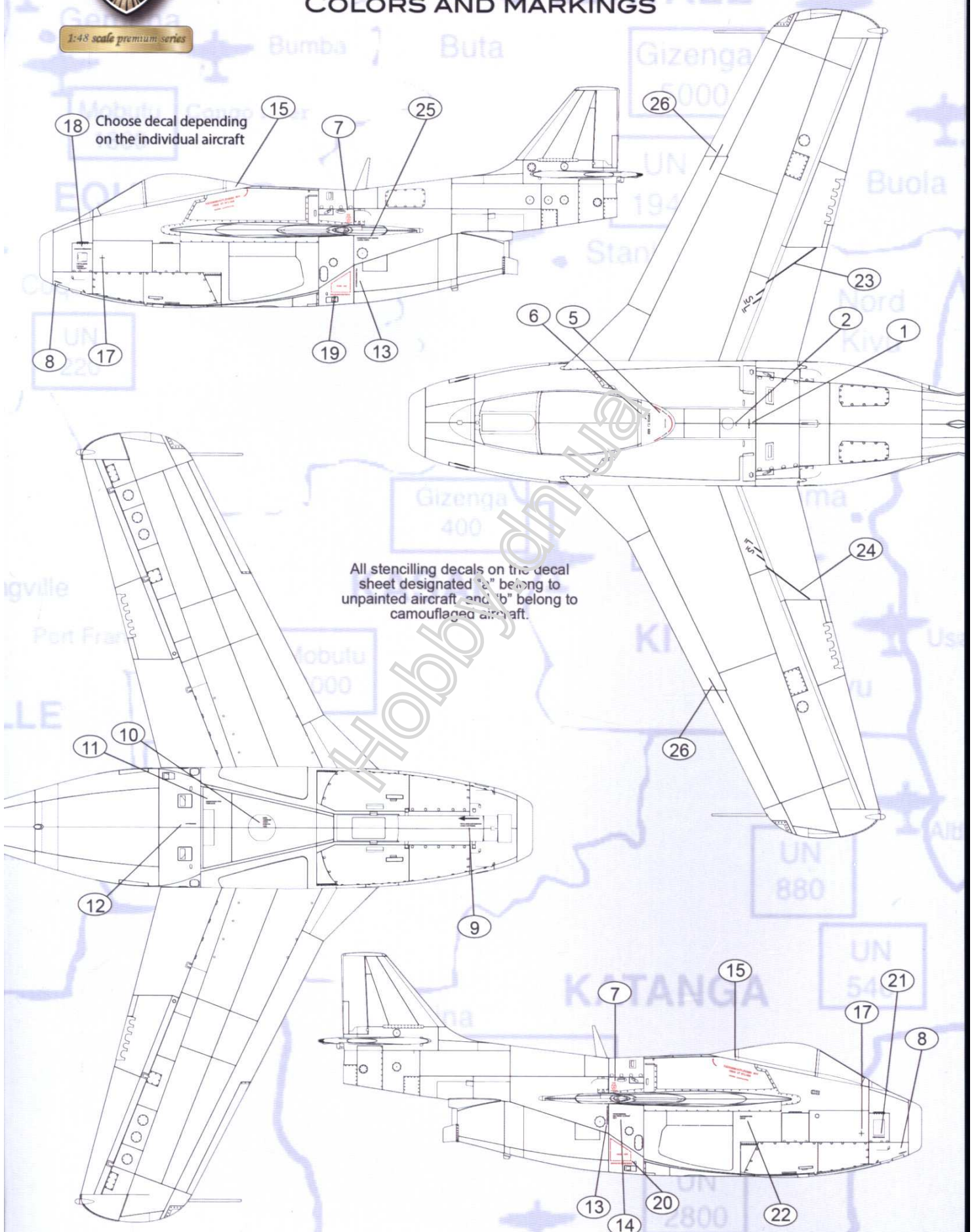



SAAB J29 B

COLORS AND MARKINGS

1:48 scale premium series

SAAB J29 B - 29393,
F 22 wing Kamina air base, Congo
February 1963



The aircraft were spray-painted with soft transitions between the colors. The underside of the aircraft was unpainted aluminum, which has a grayer character.



The aircraft were later camouflaged. The Swedish Air Force's standard colors were sent to Congo and they were mixed on site to be adapted to the local vegetation. Unfortunately, there are no exact color numbers on how they were painted, but thanks to in-depth search, we get pretty close to the truth with these colors. The specified colors are presented according to Federal Standard 595, known as SAE AMS-STD-595.

Green - 24064.

Brown - 20140.

Beige stripes - 10371

(beige stripes painted thin and extra diluted).

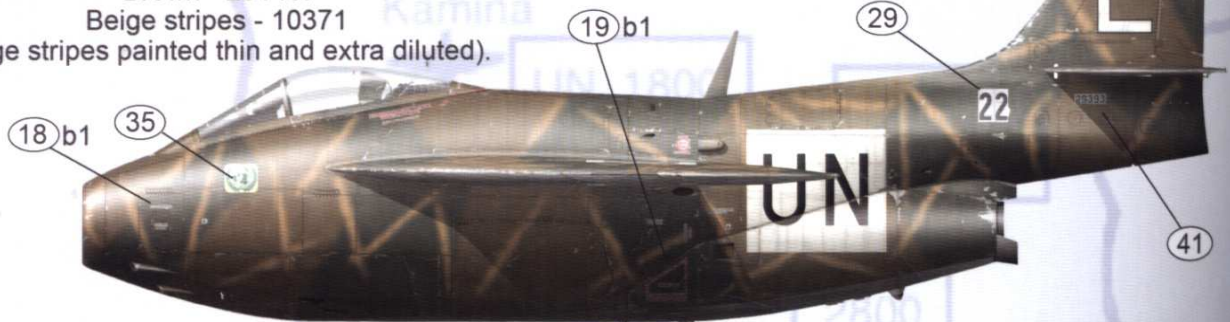



SAAB J 29 B

COLORS AND MARKINGS

1:48 scale premium series

SAAB J29 B - 29371,
F 22 wing Kamina air base, Congo
December 1962

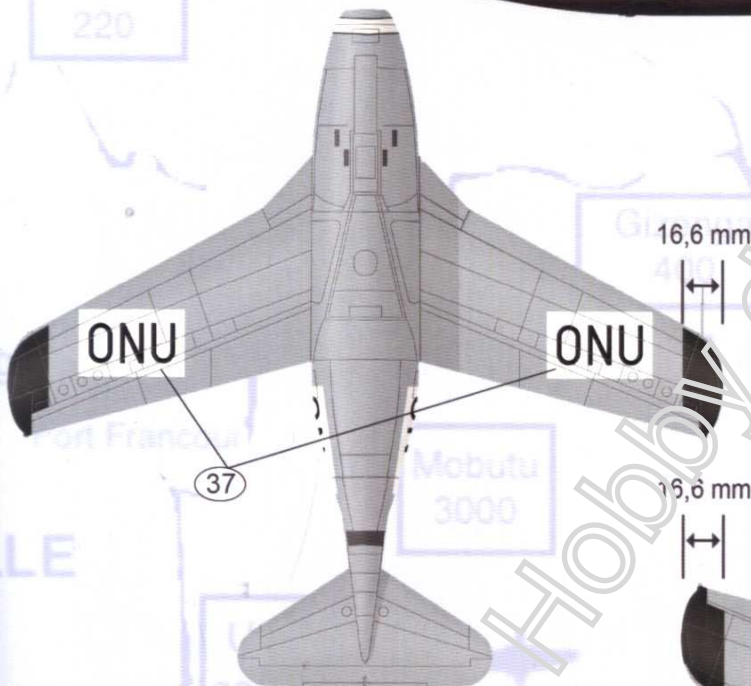

Green areas, Swedish Olive green
325M comparable to:
FS 595 - 34096 or 34079
Tamiya XF-61

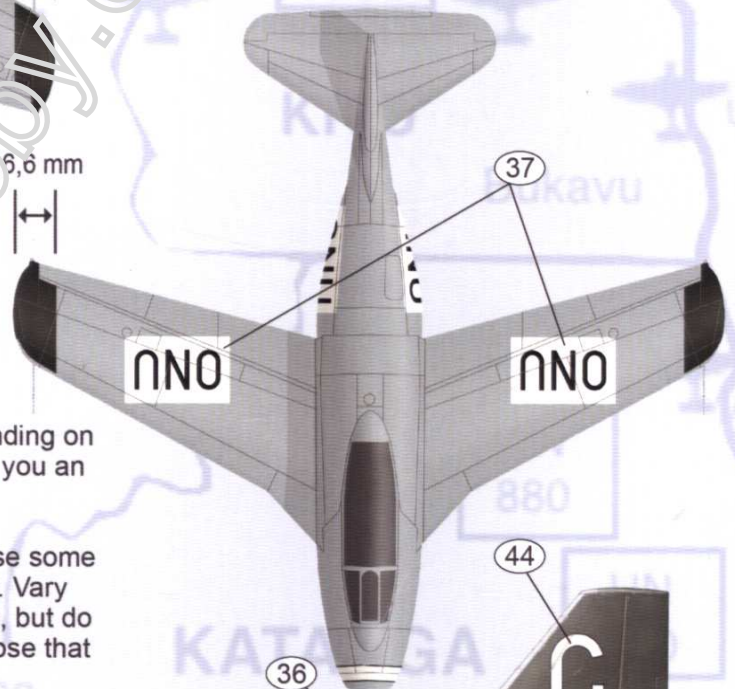

Remember that the colors of the aircraft are depending on age and wear. These color recommendations gives you an idea about the level of tint.

To reproduce the best aluminium on your J29 B, use some of the fine aluminium paints on the market today. Vary different panels with different shades of aluminium, but do not use the polished aluminium variants, rather those that are more gray.

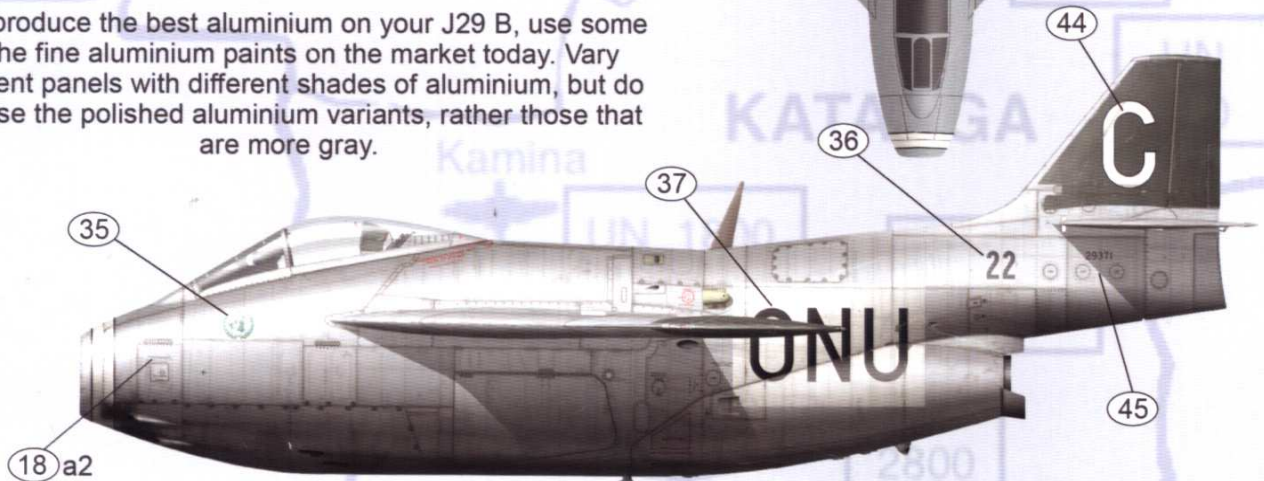



SAAB J 29 B

COLORS AND MARKINGS

1:48 scale premium series

SAAB J29 B - 29398,
F 22 wing Luluabourg air base, Congo
November 1961



All aluminium unpainted aircraft

Remember that the colors of the aircraft are depending on age and wear. These color recommendations gives you an idea about the level of tint.

To reproduce the best aluminium on your J29 B, use some of the fine aluminium paints on the market today. Vary different panels with different shades of aluminium, but do not use the polished aluminium variants, rather those that are more gray.

