



SOVA-M  
SVM-72042

# T-1A Jayhawk



UNASSEMBLED PLASTIC MODEL KITS

SCALE: 1/72

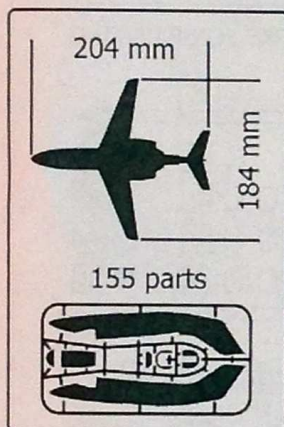

## DECALS

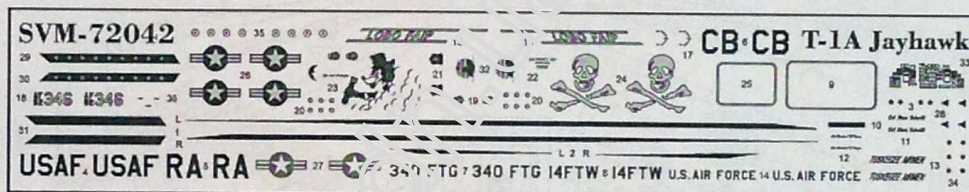

THREE VERSIONS OF COLOURING

The Hawker 400 is a light business jet. Initially designed and built by Mitsubishi, it has been further developed and updated by the Beech Aircraft Company, now part of Textron Aviation. It was produced over 30 years under the names such as Mitsubishi Diamond/Diamond II, Beechjet 400/400A, and Hawker 400XP; military version T-1 Jayhawk was also produced. In total, over 900 Hawker 400s have been delivered. Since 2017, a factory-engineered and supported upgrade to Hawker 400XPR is provided, reducing fuel consumption by 16-20%, and improving range by as much as 33%.

The model is executed on technology short run and is intended only for experienced modelers.

Word-wide distributor for Sova-M kits:  
ModelSvit Balkans Ltd. 4003 Plovdiv,  
Bulgaria 9, zk Maritza Gardens.  
Tel. +359 32 397 069,  
E-Mail: modelsvitbalkans@gmail.com  
MADE IN UKRAINE

## PAINTS

- |  |                                     |
|--|-------------------------------------|
| <b>A</b> HUMBROL 22<br>WHITE             | <b>B</b> HUMBROL 19<br>RED          |
| <b>C</b> HUMBROL 27002<br>POL. ALUMINIUM | <b>D</b> HUMBROL 27004<br>GUN METAL |
| <b>E</b> HUMBROL 145<br>MEDIUM GREY      | <b>F</b> HUMBROL 33<br>BLACK        |
| <b>G</b> HUMBROL 21<br>BLACK             |                                     |

## SYMBOLS

- |                                  |                   |               |
|----------------------------------|-------------------|---------------|
| <b>1</b> STAGES OF ASSEMBLY      | TO PAINT          | TO BEND       |
| <b>1</b> NUMBER PARTS            | GLUE              | SCRATCH BUILT |
| APPLY DECALS                     | DON'T GLUE        | OPEN HOLE     |
| <b>x2</b> QUANTITY OF OPERATIONS | НА ВИБІР OPTIONAL | CAT OUT       |

# SET OF THE PARTS



 PARTS NOT FOR USE

**P**

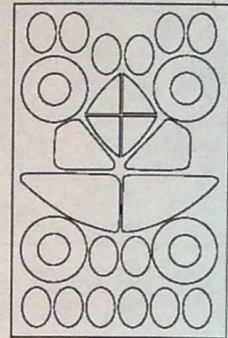
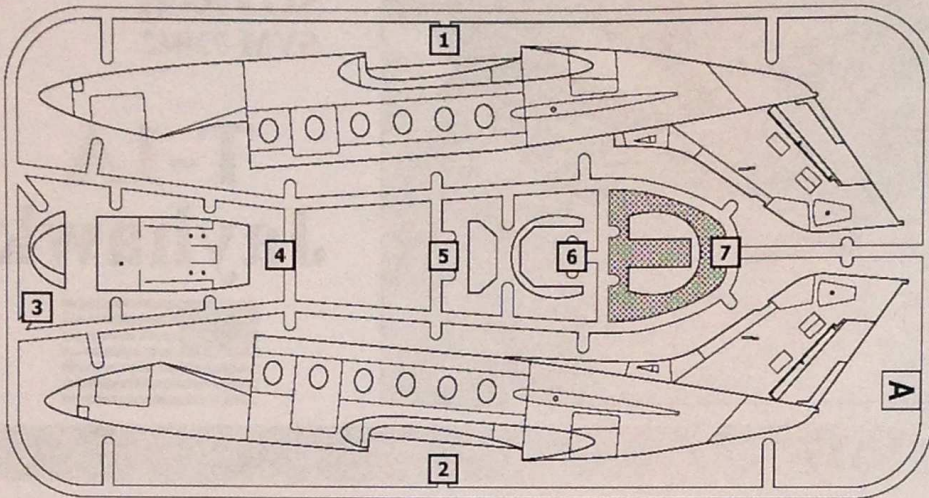
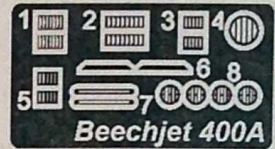

MASKS FOR PAINTING

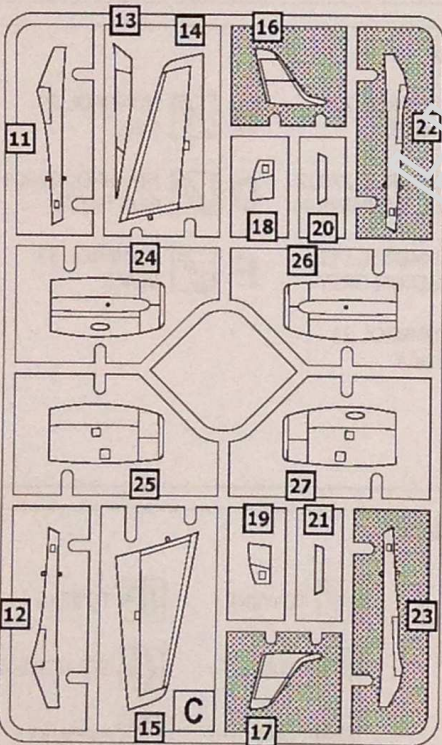
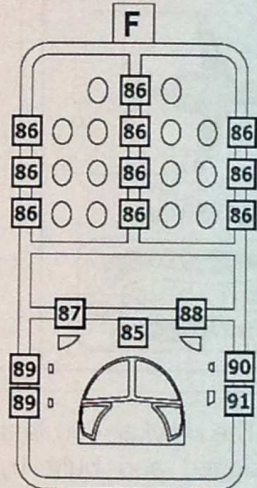
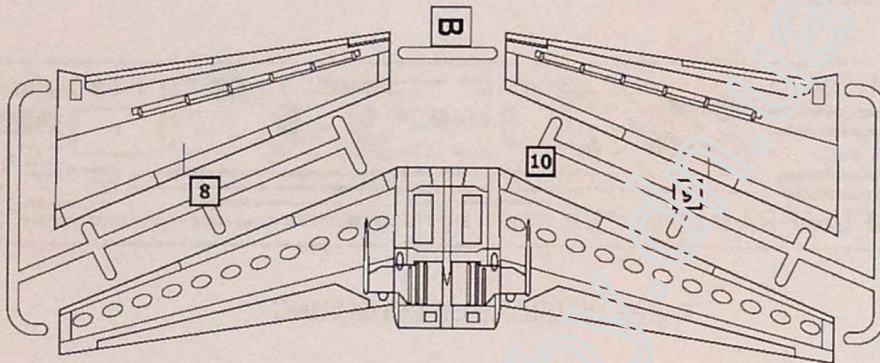

x2

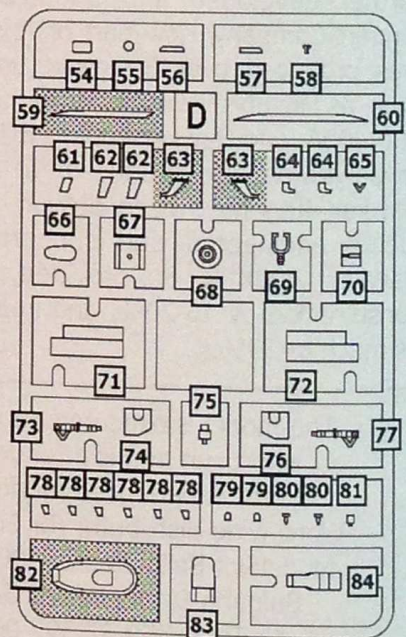
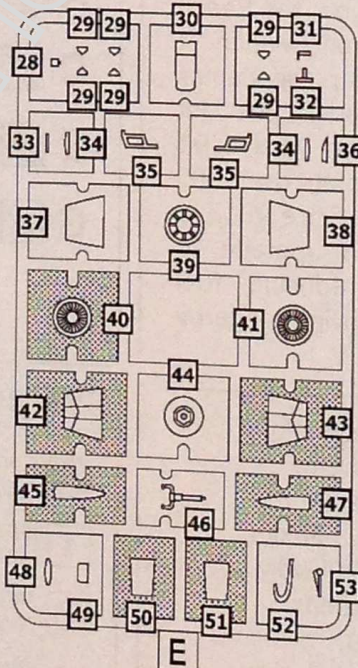

# ASSEMBLY INSTRUCTION



- 1** x2
- 30** x2
- 34** x4
- 35** x4

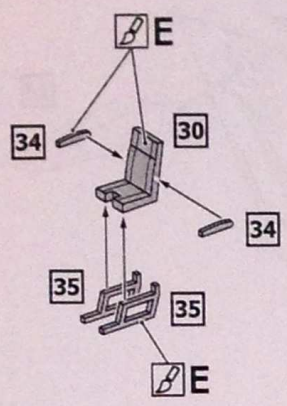

- 2**
- 1** x2
- 4**
- 6**
- 32** x2
- 46** x2
- 58**
- 71**
- 72**
- 75**
- 83**
- 84**

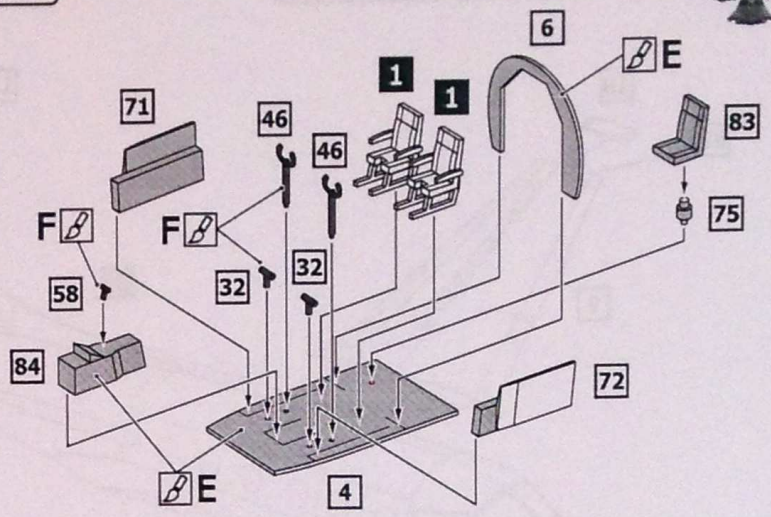

- 3**
- 2**
- 1**
- 2**
- 3**
- 5**
- 67**
- 85**
- 86** x12
- P3**

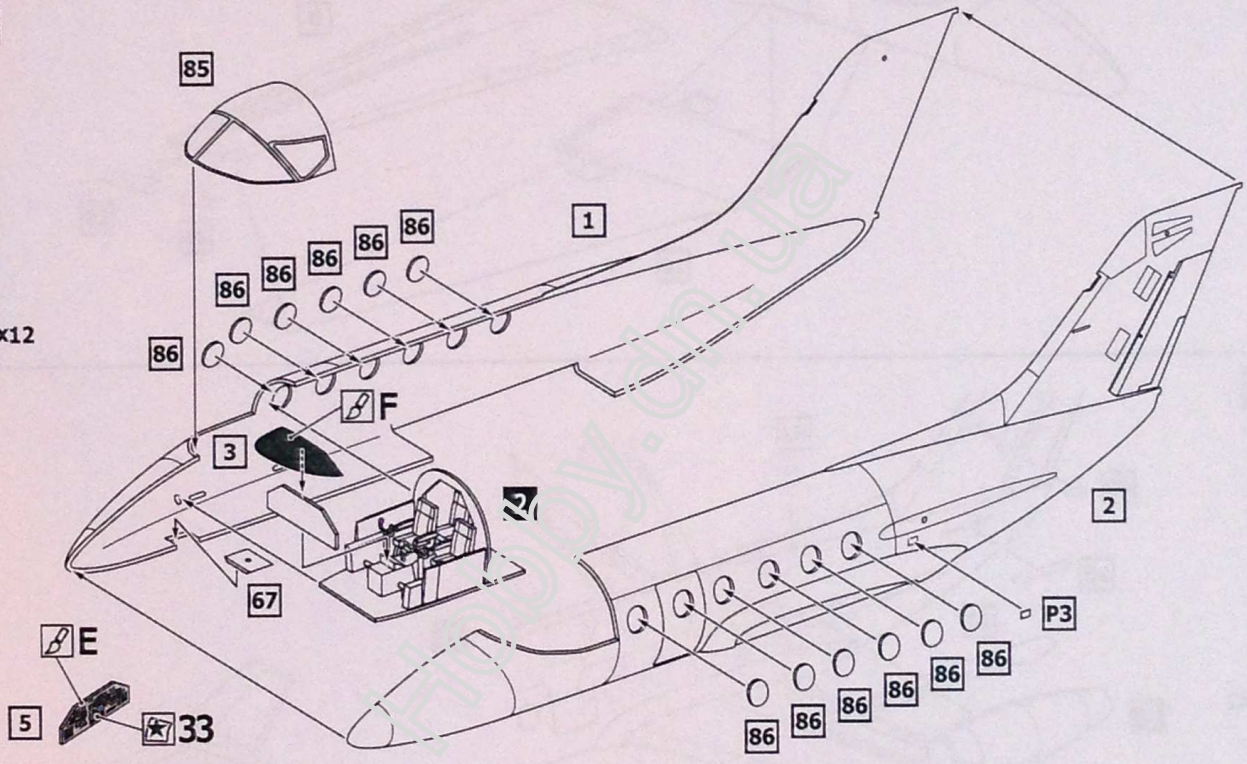

- 4**
- 24**
- 25**
- 37**
- 38**
- 39**
- 41**

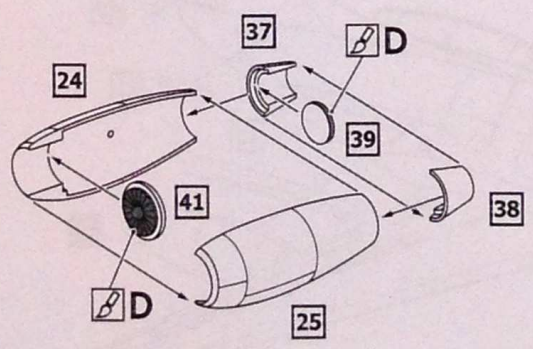

- 5**
- 26**
- 27**
- 37**
- 38**
- 39**
- 41**

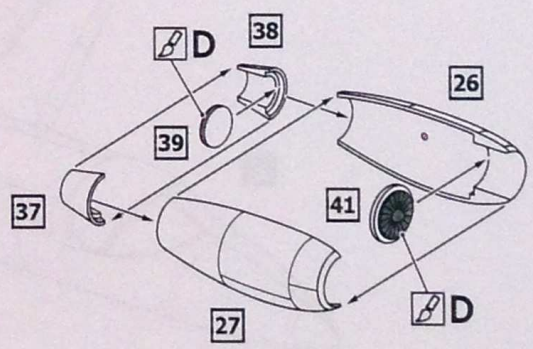

# ASSEMBLY INSTRUCTION



- 6**
- 3**
- 8**
- 9**
- 10**
- 14**
- 15**
- 18**
- 19**
- 87**
- 88**

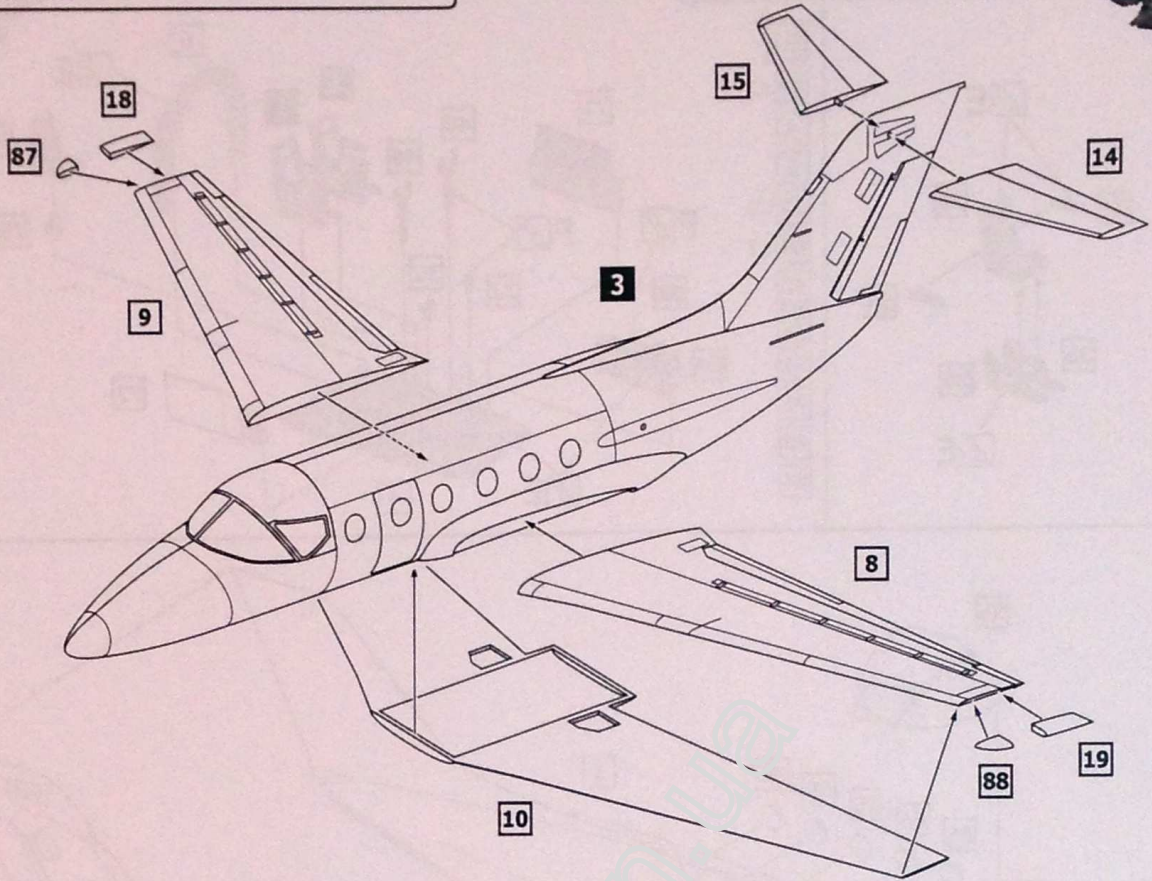

- 7**
- 4**
- 5**
- 6**
- 11**
- 12**
- 20**
- 21**
- 49** x2
- 62**

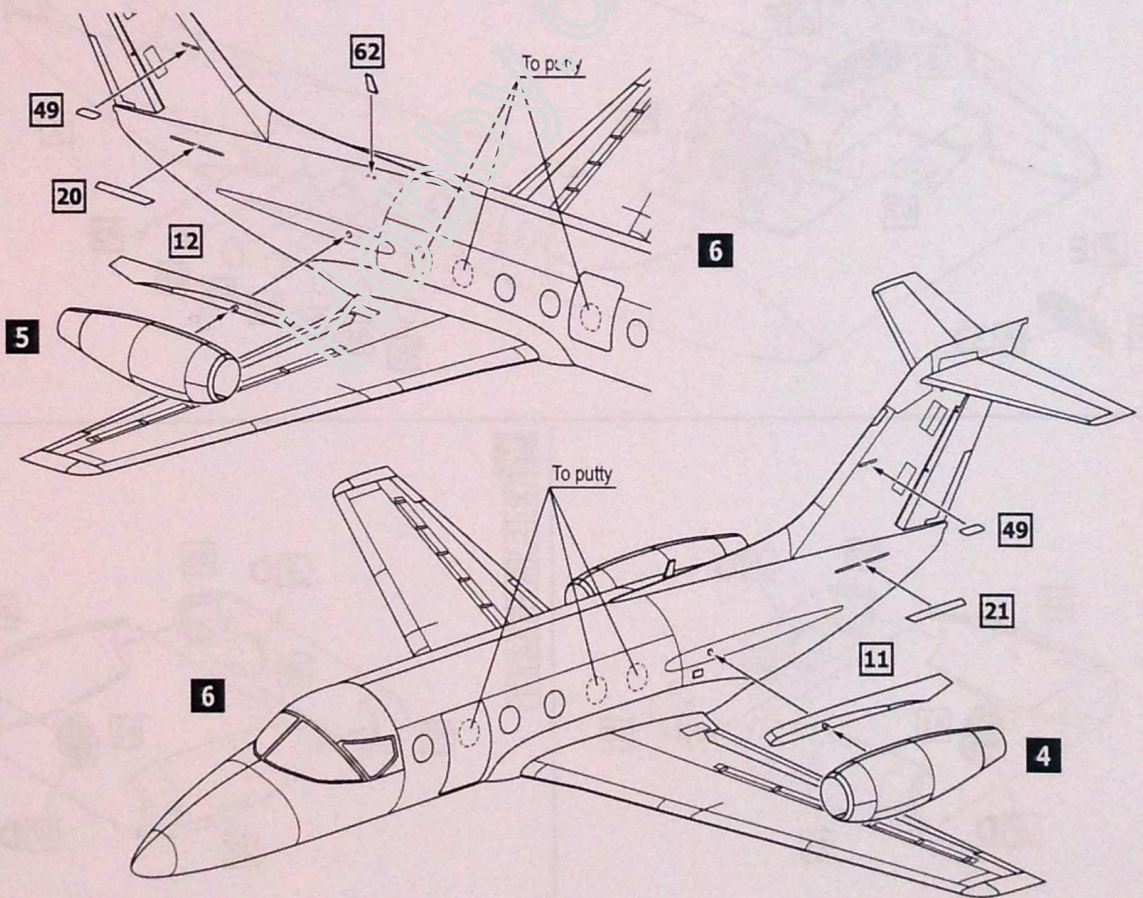

# ASSEMBLY INSTRUCTION



**8**

**7**

**36** x2

**52** x2

**54**

**55**

**61**

**66**

**78**

**81**

**89**

**P1** x2

**P4**

**P6** x2

**P7** x2

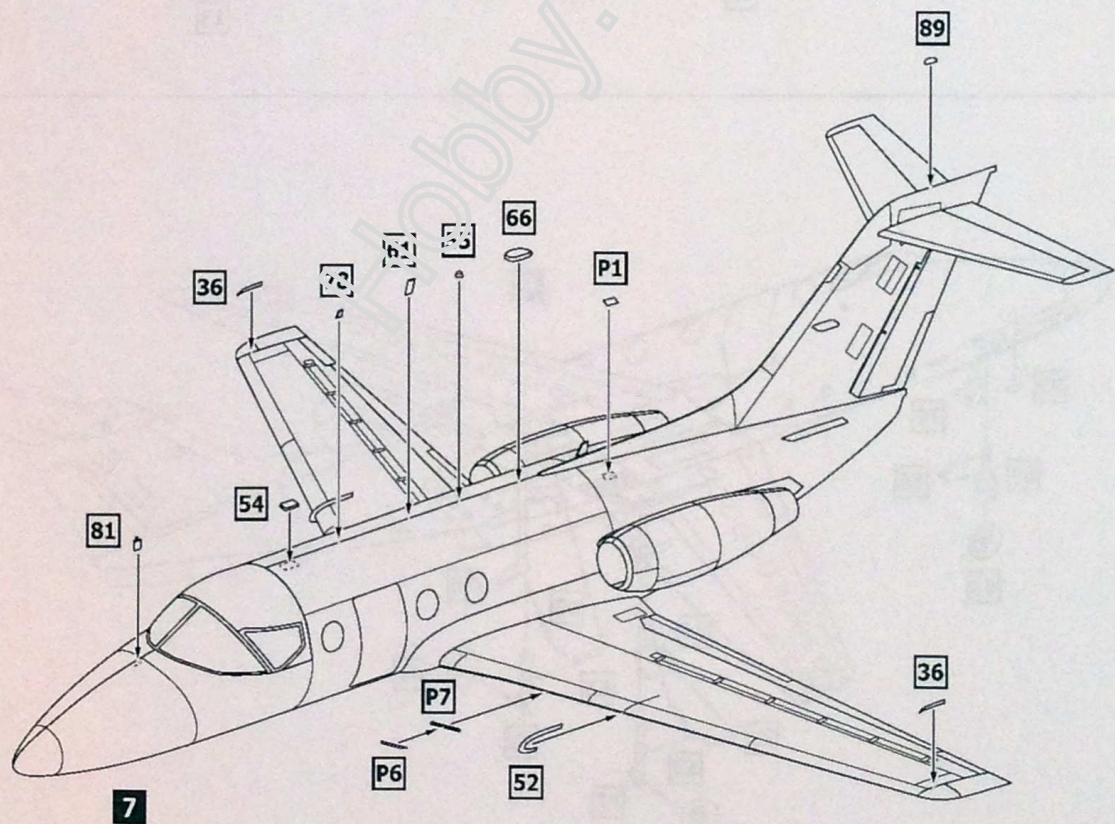
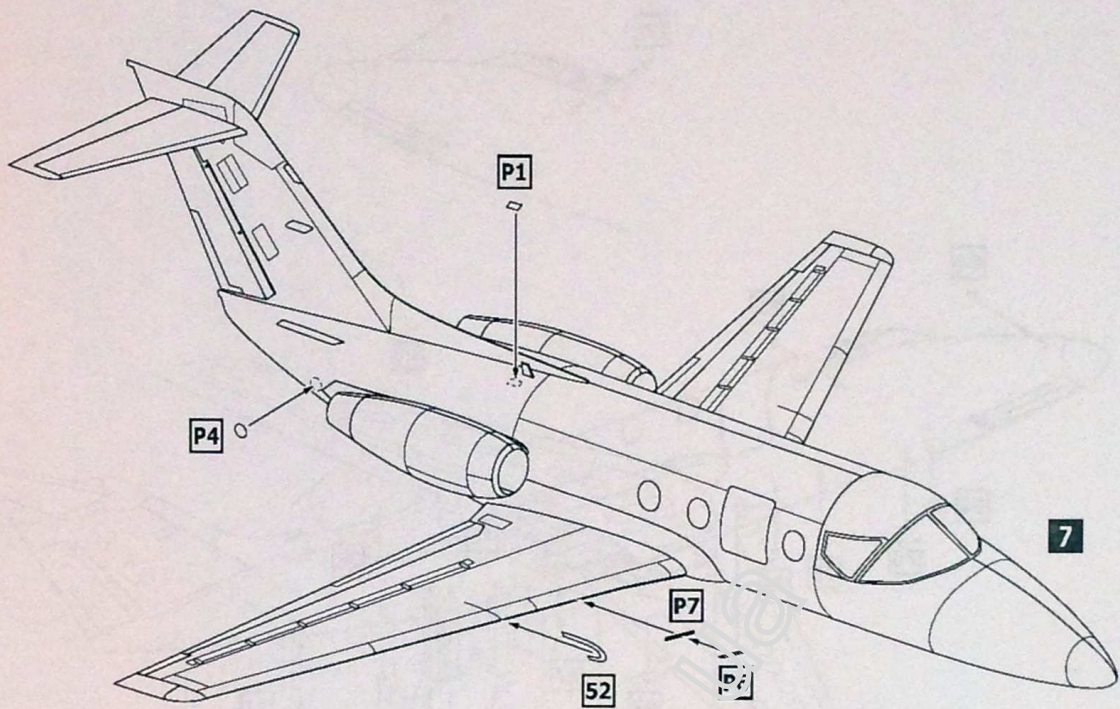

# ASSEMBLY INSTRUCTION



**9**

**8**

**13**

**28** x2

**29** x12

**31** x2

**48** x2

**56**

**57**

**60**

**62**

**64** x2

**78** x3

**79** x2

**80** x2

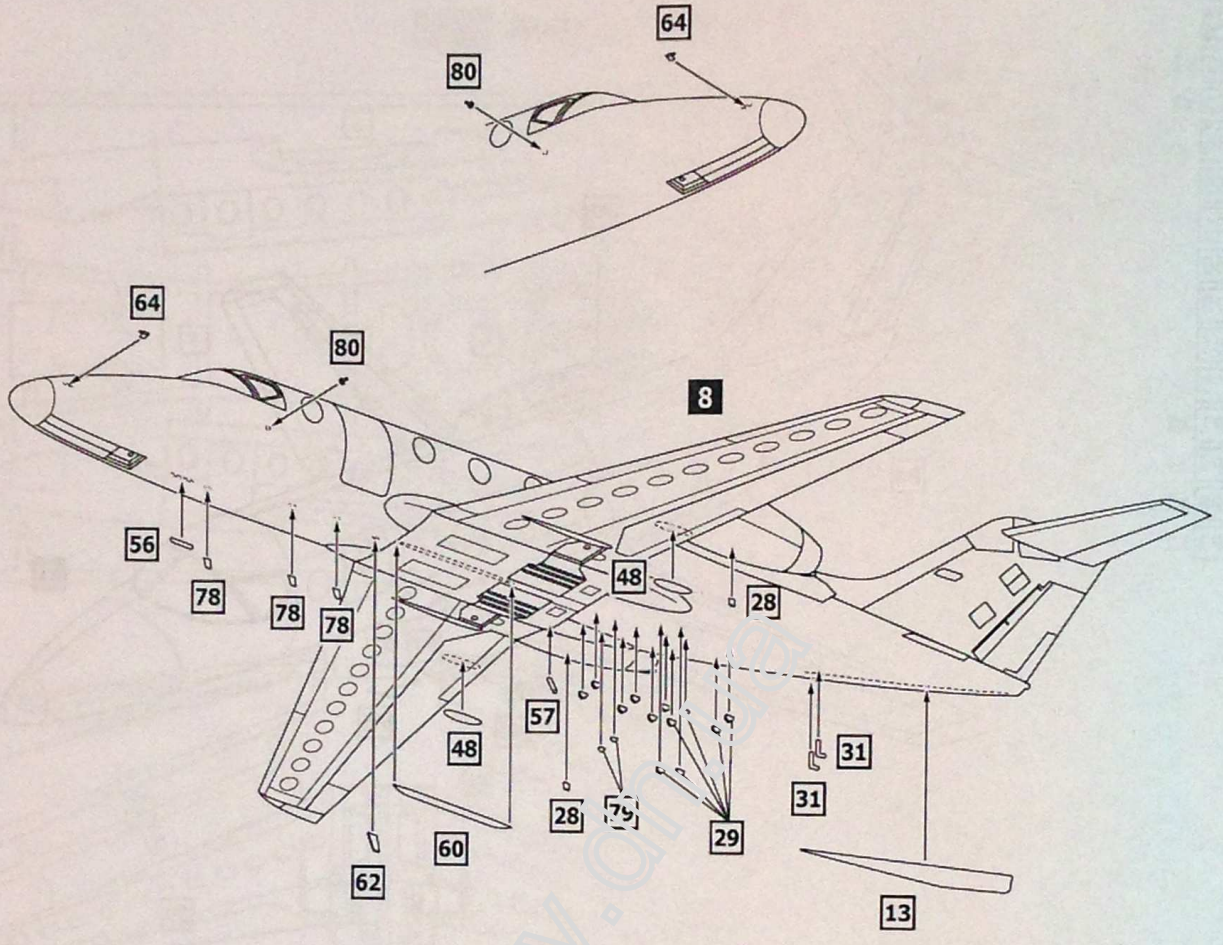

**10**

**9**

**33** x2

**44** x2

**53** x2

**65**

**68**

**69**

**70**

**73**

**74**

**76**

**77**

**P2**

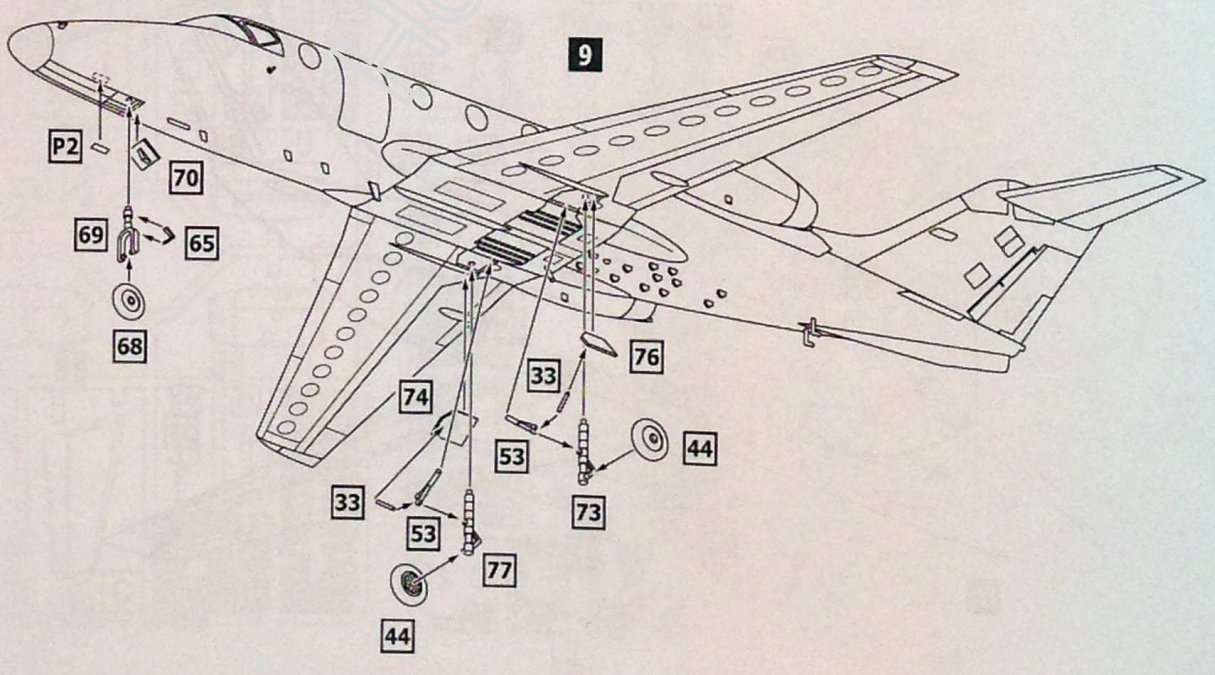

**6**



# MARKING & PAINTING

T-1A Jayhawk

15 ★

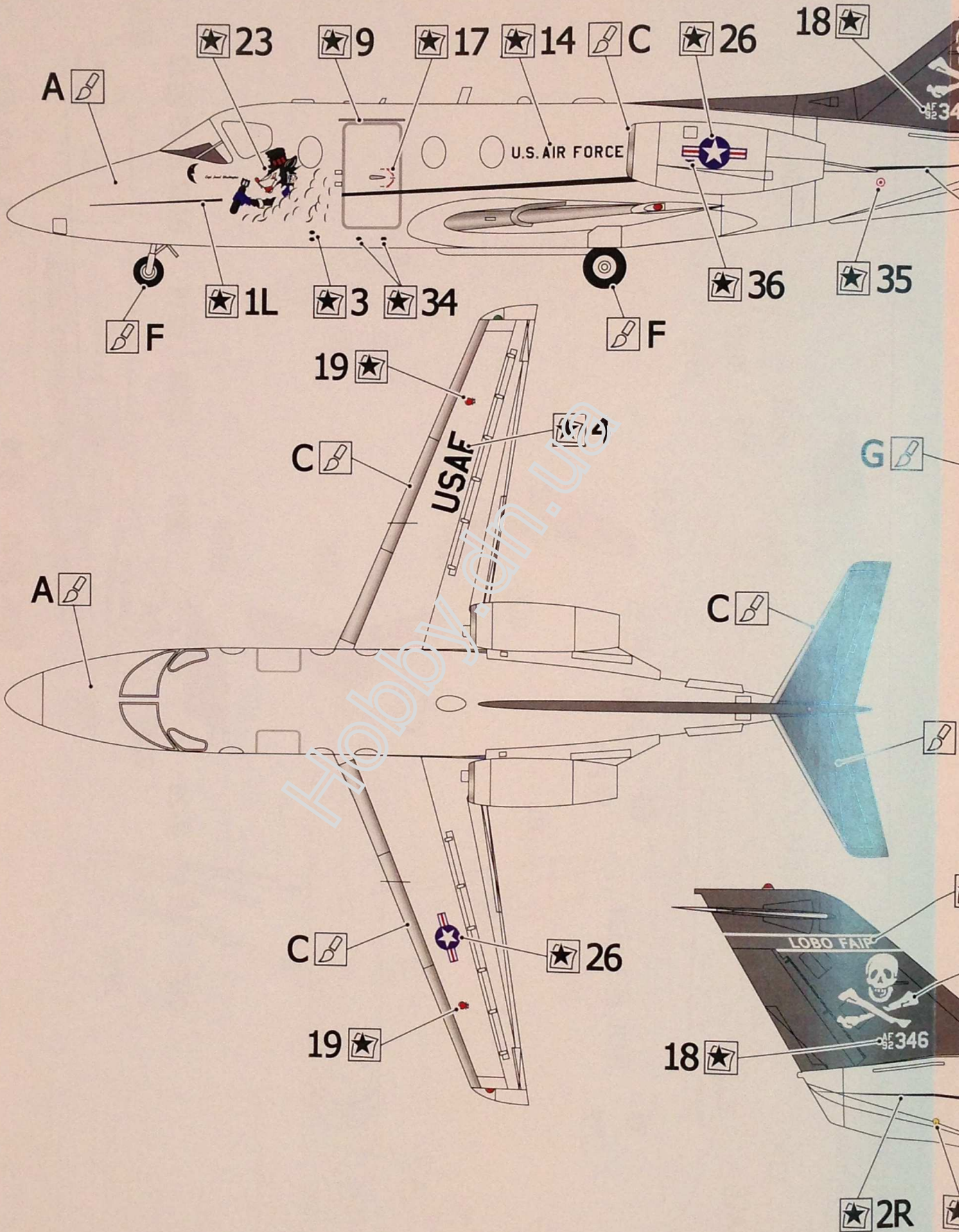



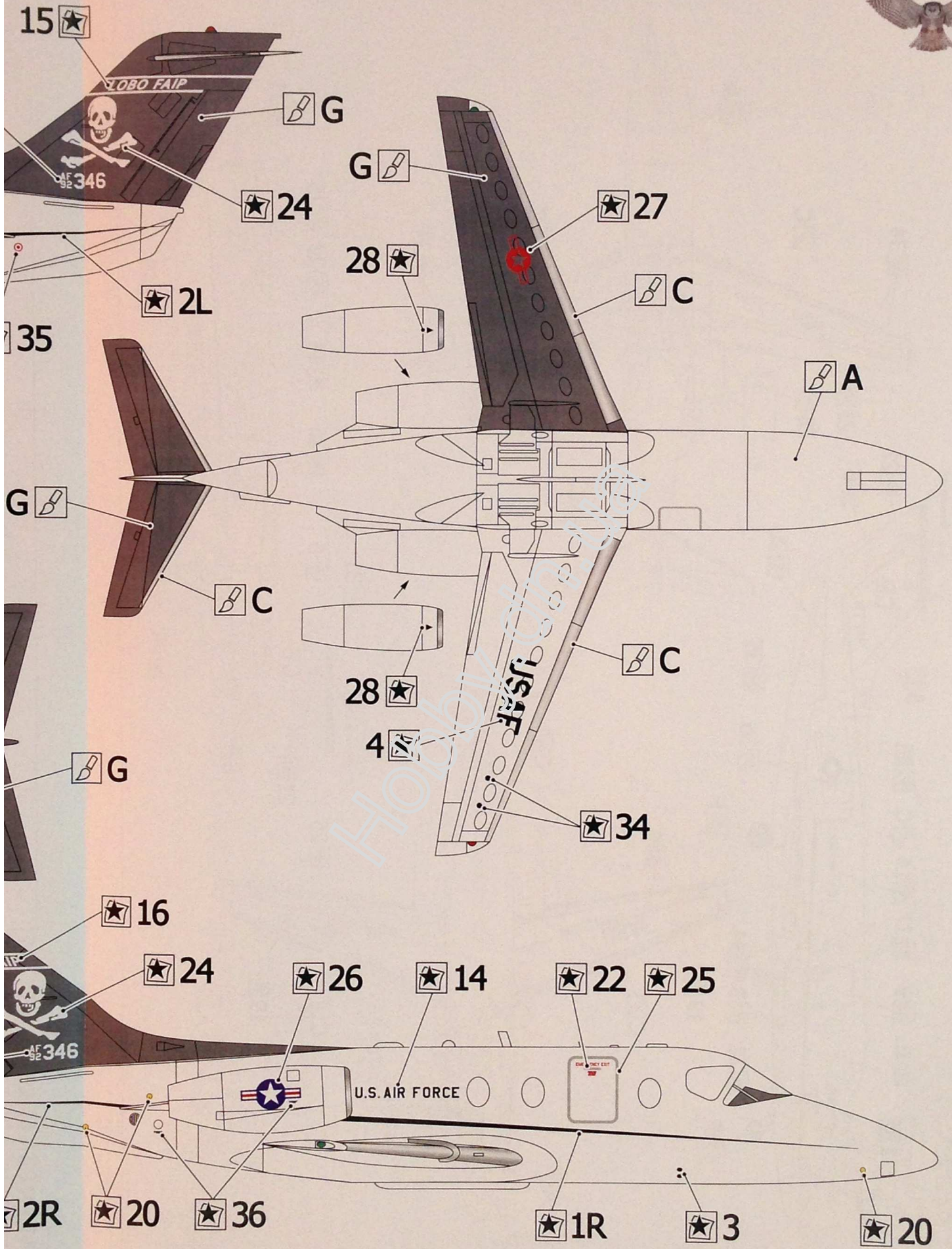

# MARKING & PAINTING

T-1A Jayhawk

