

Westland Whirlwind FB MK.I 'Fighter-Bomber'

1/32

CZ

Na základě specifikací F.37/35, které požadovaly těžce vyzbrojenou stíhačku pro boj s bombardéry, vznikl u firmy Westland projekt P.9, dvomotorový stroj s výbrojí čtyř kanonů ráže 20 mm. V únoru 1937 RAF uzavřelo s firmou Westland smlouvu na postavení dvou prototypů. První z nich, L6844 vzlétl poprvé 11. října 1938. Následovaly dva roky zkoušek, do kterých se zapojil i druhý prototyp L6845. Během těchto zkoušek se měnily hlavně ocasní plochy a byly zrušeny sloty. Sériové stroje se začaly vyrábět v roce 1940. Do výbroje je dostala 263. squadrona RAF. V roce 1941 je dostala další jednotka 137. squadrona RAF. Další jednotky už tímto strojem vyzbrojeny nebyly. Na vině byly hlavně motory R&R Peregrine. Byly nespolehlivé a navíc jejich produkce byla zastavena ve prospěch potřebnějších Merlinů. To vedlo i k zastavení výroby Whirlwindů. Ty přitom byly rychlé a obratné, údajně byly schopné vymanévrovat i jednomotorovou stíhačku. A při své silné výbroji čtyř kanonů představovaly nebezpečného protivníka. Jejich silná výbroj byla později posílena i montáží závěsníků bomb pod křídlo. Takto upravené Whirlwindy byly označeny FB Mk.I nebo Mk.IA a nasazeny do bitevních akcí. Jejich úspěchy při útocích na německou lodní dopravu v Kanálu La Manche a v okupované Francii jim vynesly přezdívku Whirlbomber. Whirlwindy bojovaly v první linii do konce roku 1943, pak byly vyřazeny. Na prototypu L6844 byly testovány různé varianty výbroje, např. dvanáct kulometů nebo kanon ráže 37 mm.

Rozpětí: 13,73 m, délka: 9,84 m, max. rychlost: 579 km/h, dolet: 1000 km, dostup: 9150 m.

EN

Project Wesland P.9 was designed upon F.37/35 Specifications that called for escort fighter with heavy armament. P.9 project was a twin engined aircraft with four 20 mm cannons. In February 1937 RAF and Westland signed a contract for manufacture of two prototypes. The first prototype L6844 took off for the first time on October 11, 1938. Following two years were both prototypes, the second was L6845, thoroughly tested and it subsequently led to the tail planes changes and deleting of slats. The production of the series machines began in 1940 and they were assigned to the RAF 263. Squadron. Another squadron, this time RAF 137. was equipped with Whirlwinds in 1941. Due to the R&R Peregrine engines no other units were equipped with Whirlwinds. These engines were unreliable and moreover their production was stopped on behalf of more needed Merlins. This also led to the production being stopped. Even though the Whirlwinds were fast, highly maneuverable and reputedly they were even capable to outmaneuver single engined fighter. Further, the heavy armament consisting of four cannons made the Whirlwind deadly opponent. The heavy armament was later intensified by addition of two wing mounted bomb racks. These modified Whirlwinds were designated FB Mk.I or Mk.IA and were used for ground attack missions. Their successful attacks on German ships in La Manche Channel and in occupied France earned them a nickname Whirlbomber. Whirlwinds fought in first line combat until the end of 1943 and then were withdrawn. The L6844 protoype was used as test bed for various armament layouts, such as 12 machine guns or 37 mm cannon.

Wingspan: 13.73 m, length: 9.84 m, max. speed: 579 km/h, range: 1,000 km, service ceiling: 9,150 m.

Plastic Parts

Clear Parts

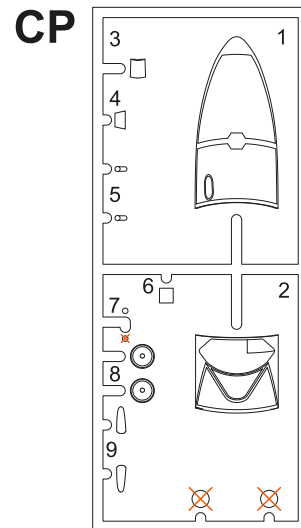
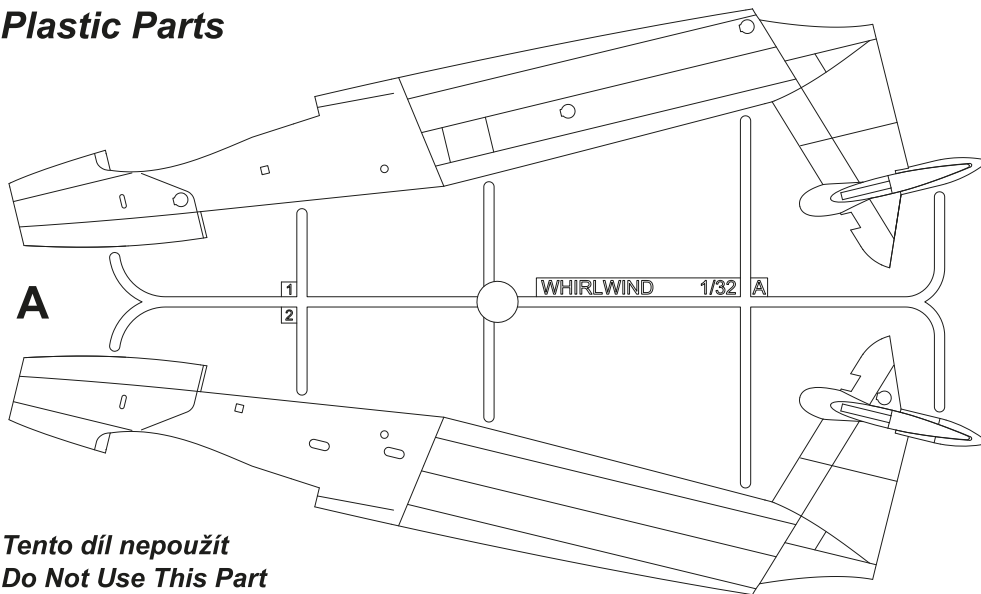

X Tento díl nepoužít
Do Not Use This Part

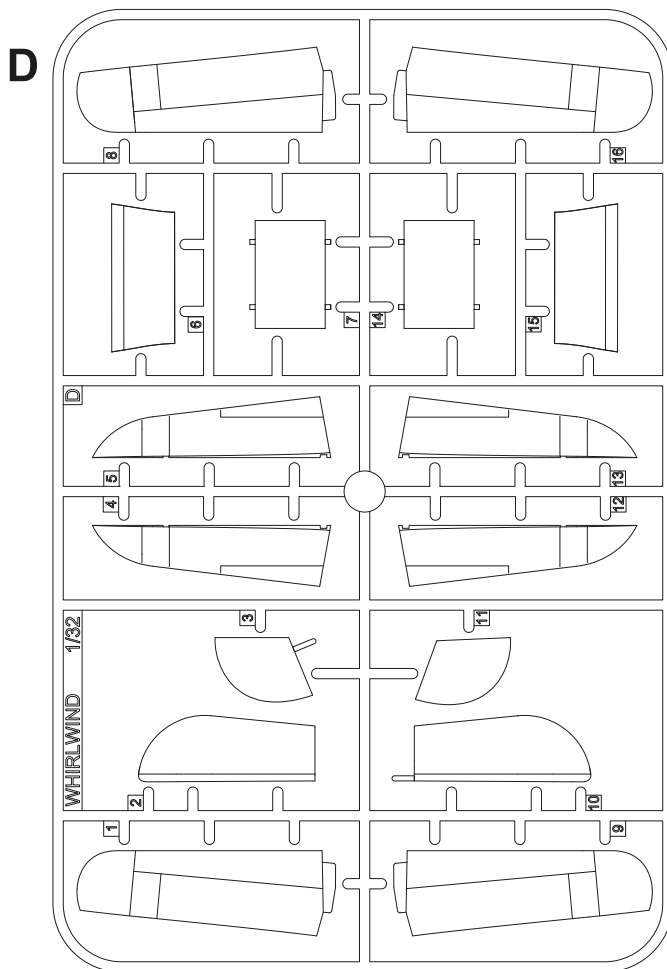
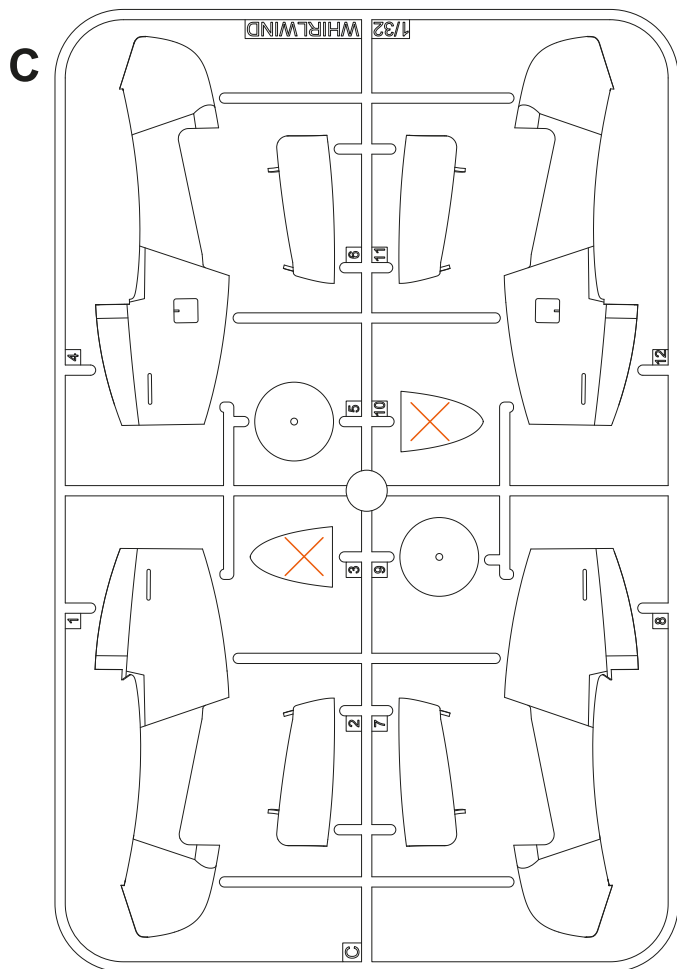
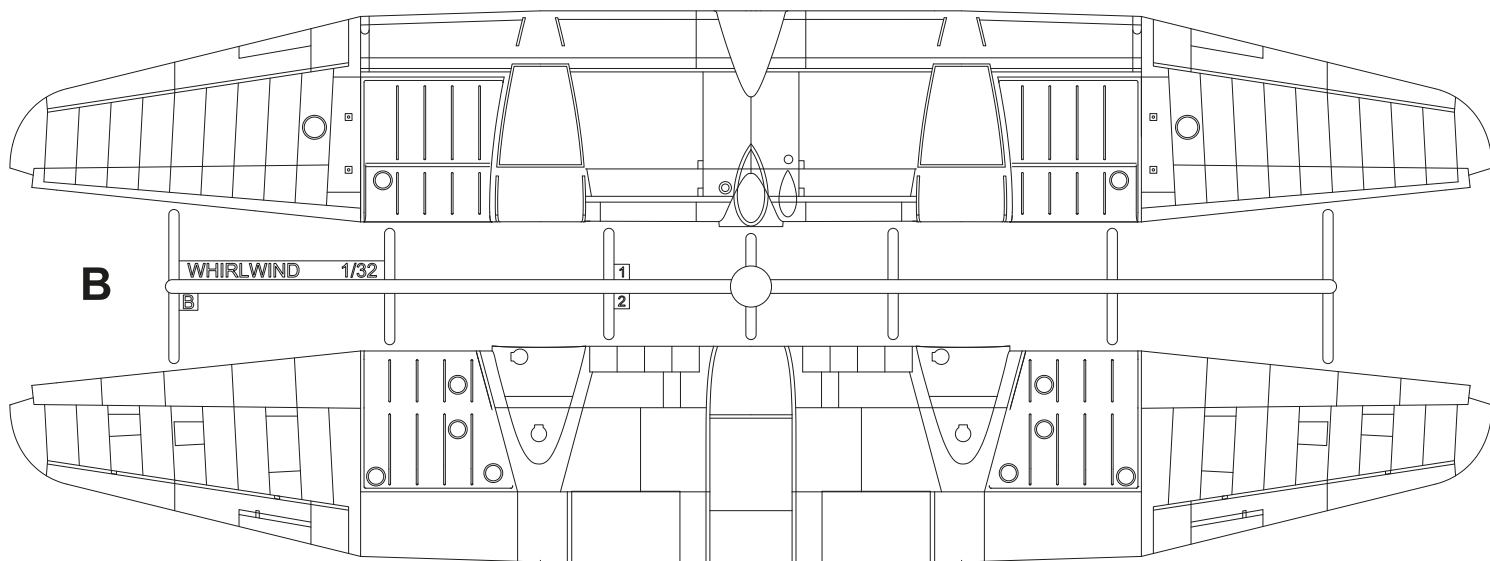

M

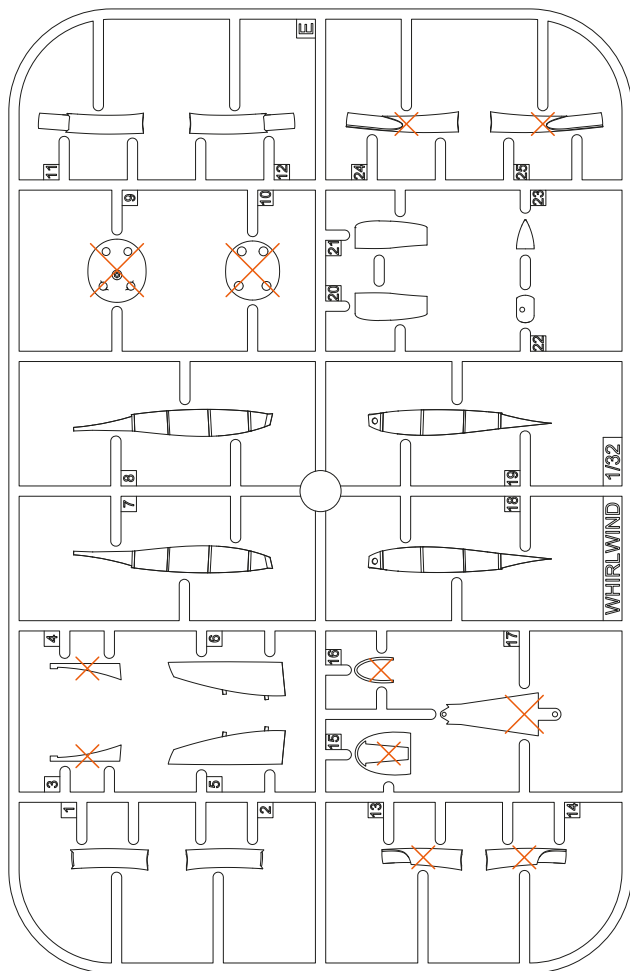

2x
F

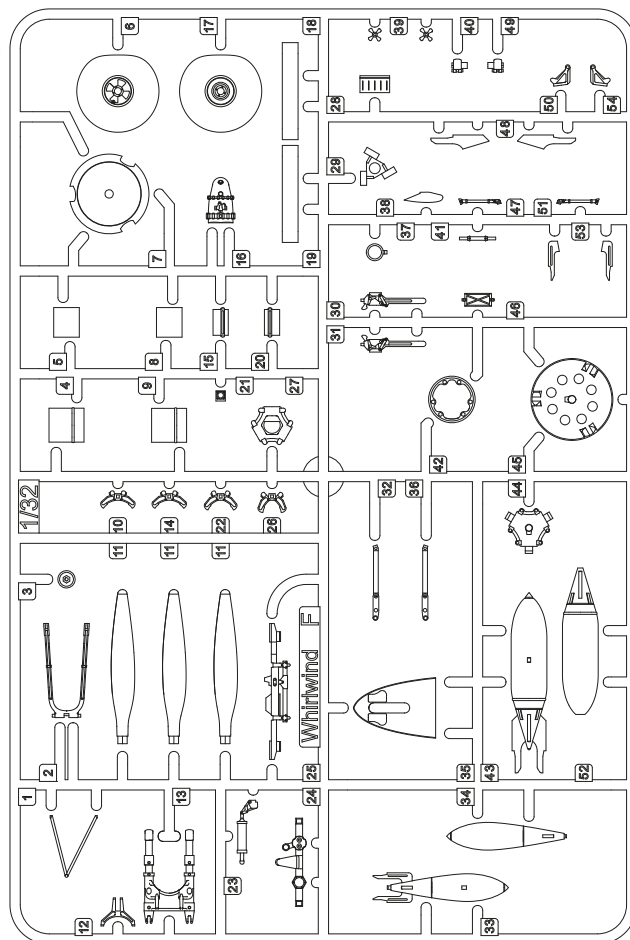

G

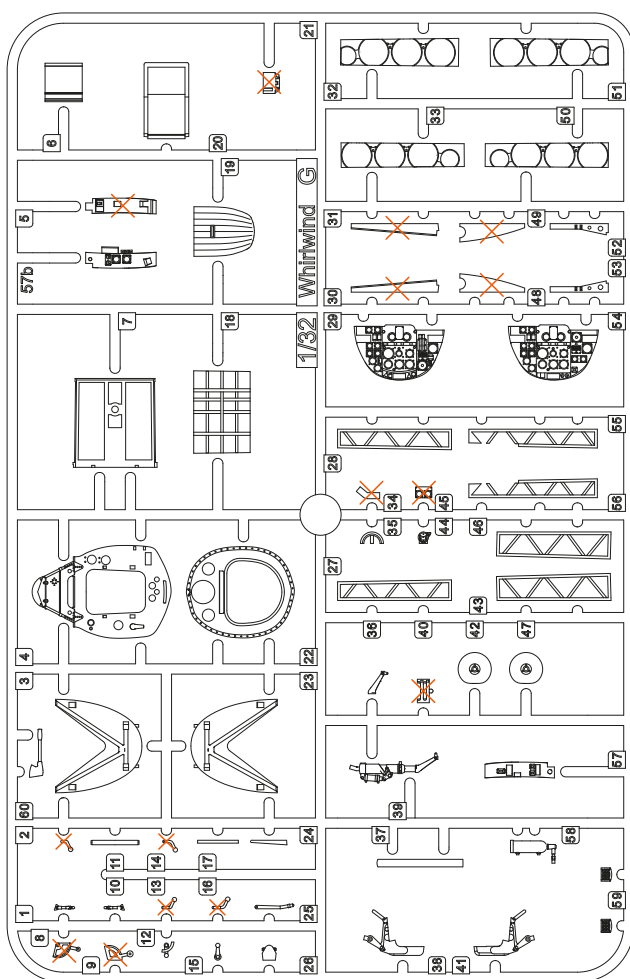

H

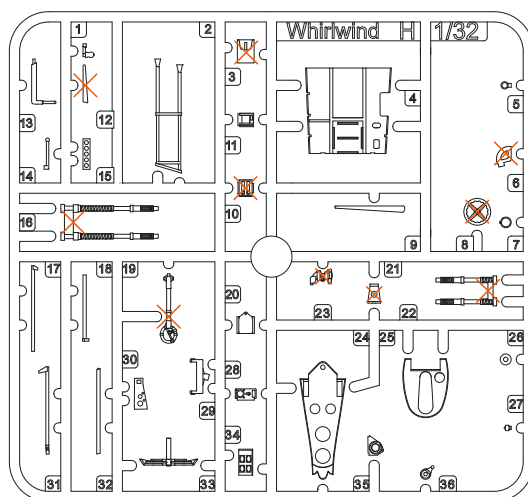

Barvy GUNZE / GUNZE Colour No.

A	Černá / Black	H12 / C33
B	Barva pneu / Tyre Black	H77 / C137
C	Tmavý kov / Dark Iron	MC214
D	Hliník / Aluminium	MC218
E	Hnědočervená / Red Brown	H47 / C41
F	Opálený kov / Burnt Iron	H76 / C61
G	Interiér. šedozeleá / Interior Grey Green	H364 / C364
H	Červená / Red	H3 / C3
I	Žlutá / Yellow	H4 / C4
J	Zelená / Green	H302 / C302



MOŽNOST VOLBY
OPTIONAL
NACH BELIEBEN
OPTION



POUŽIT KYANOAKRYLÁTOVÉ LEPIDLO
INSTANT CYANOACRYLATE GLUE
ZYANOAKRYLATKLEBER
COLLE CYANOACRYLAT



OHNOUT
BEND
BIEGEN
COURBER



ZHOTOVIT NOVÉ
SCRATCH BUILD
FERTIGSTELLEN
ACHEVER



ŘEZAT/VRTAT
CUT OFF/DRILL
ENTFERNEN
DETACHER



NATRÍT
COLOUR
FARBEN
PEINDRE

SYMBOLS

Polyuretan Parts (PUR)

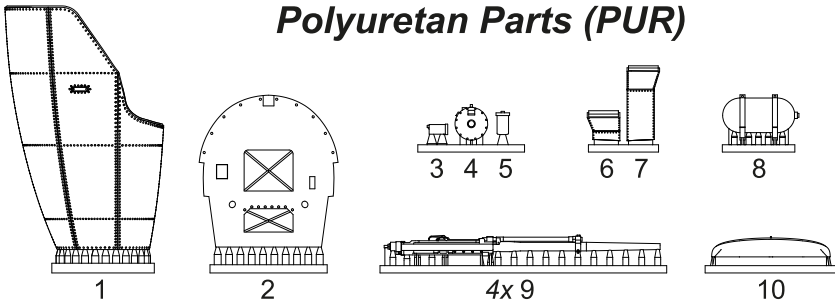

Printed Parts (PRP)

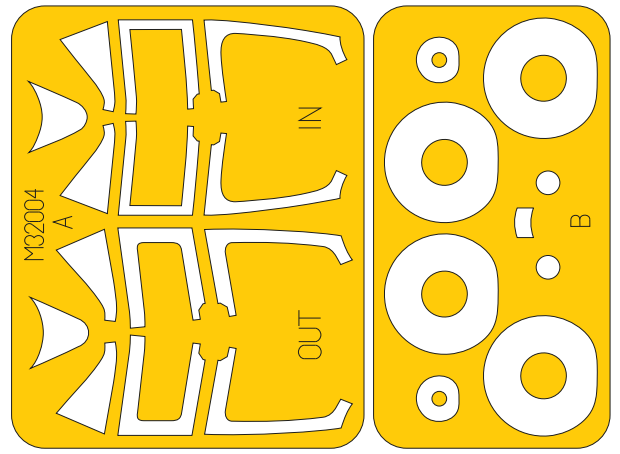
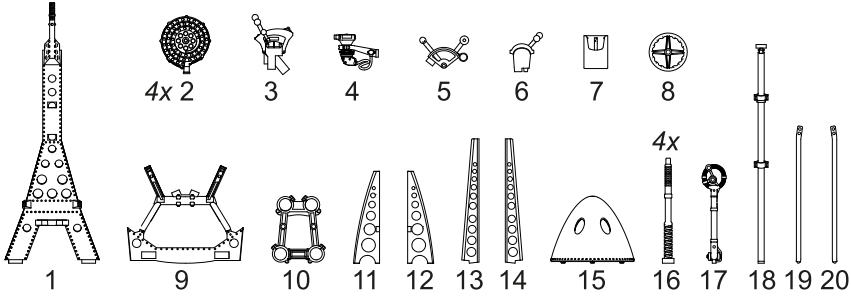
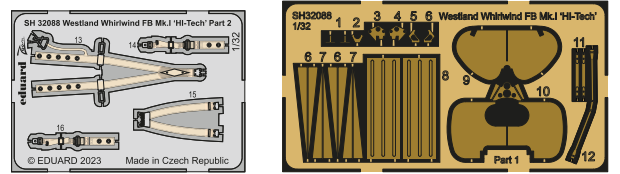
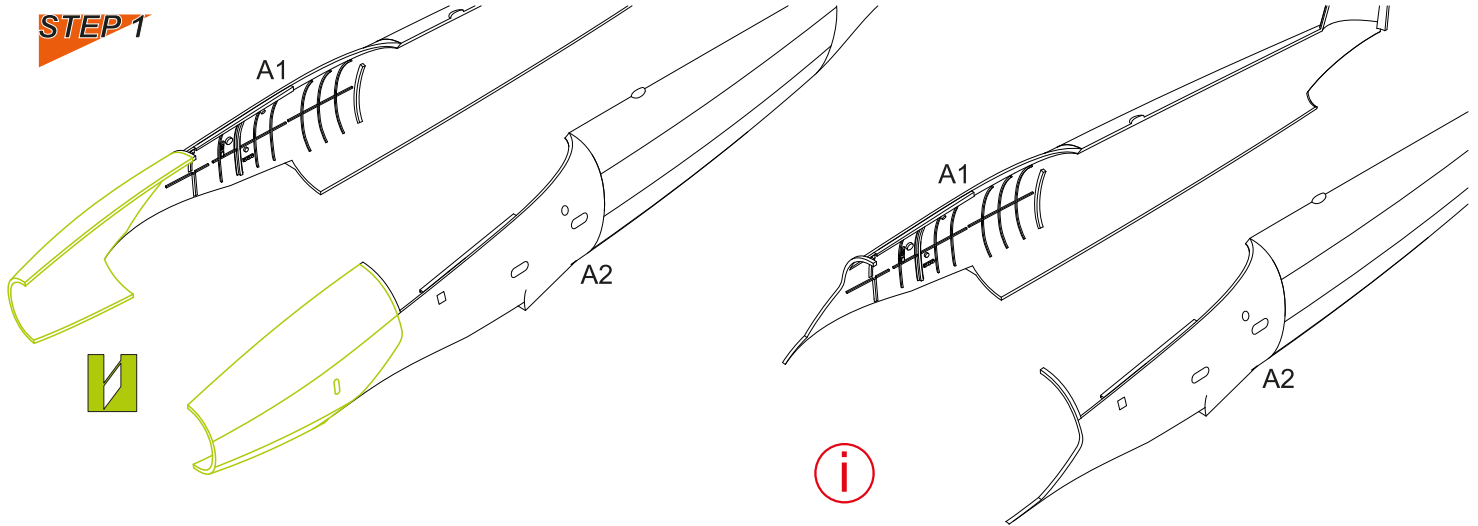

Photo-Etched Parts (PP)



Assembly

STEP 1



STEP 2

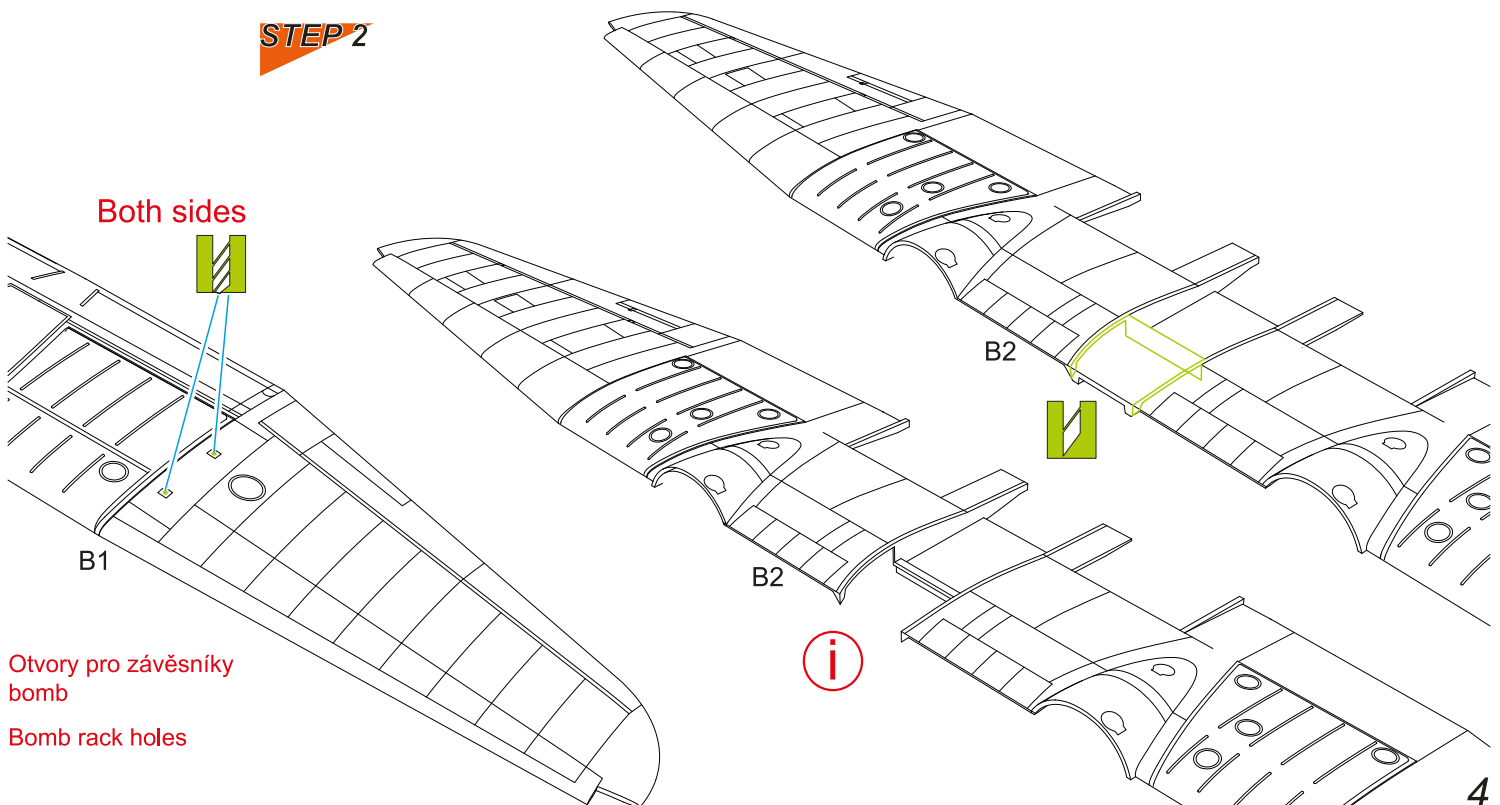

Both sides

Otvory pro závěsníky bomb

Bomb rack holes

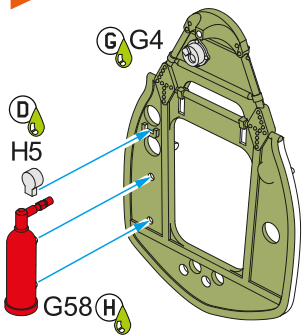
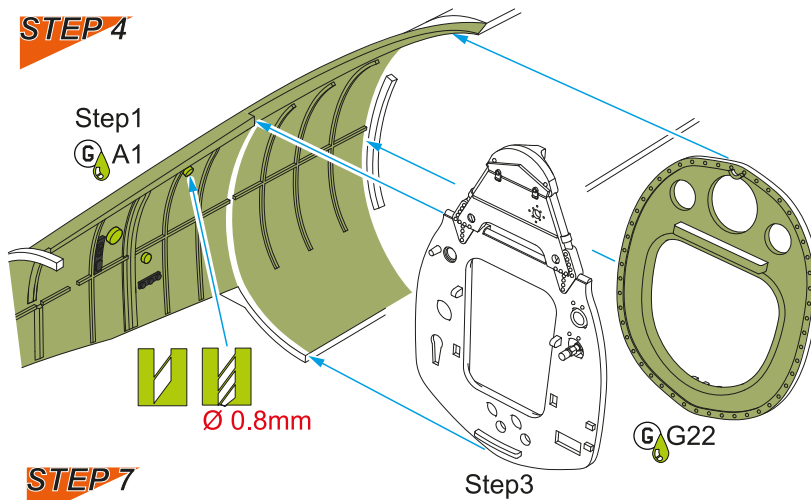
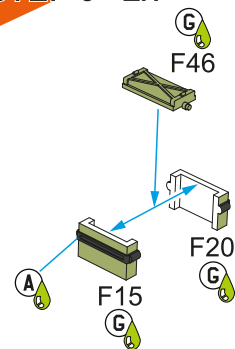
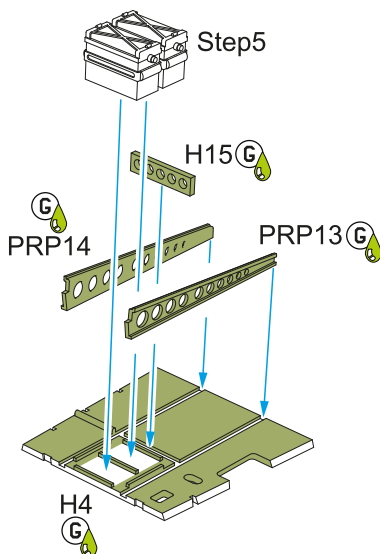
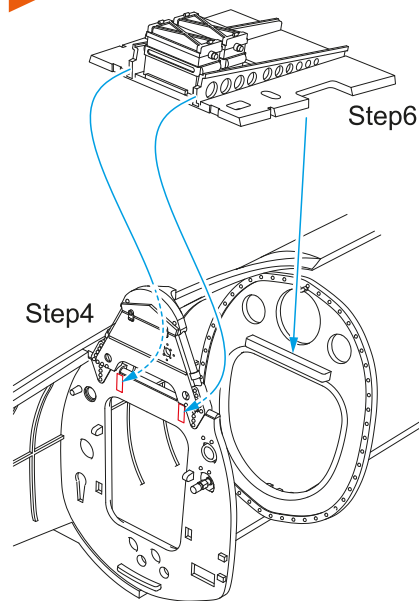
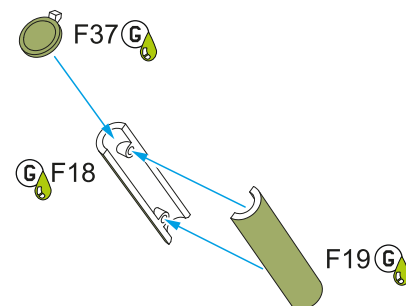
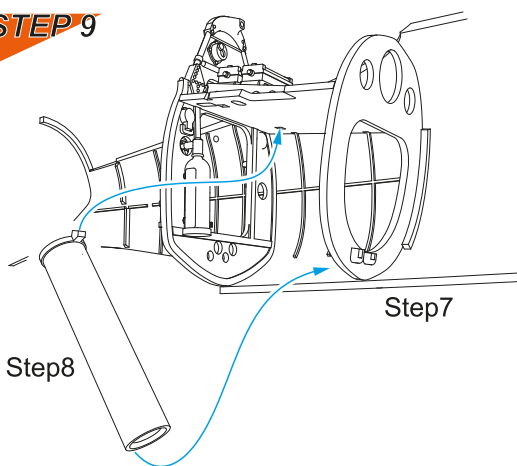
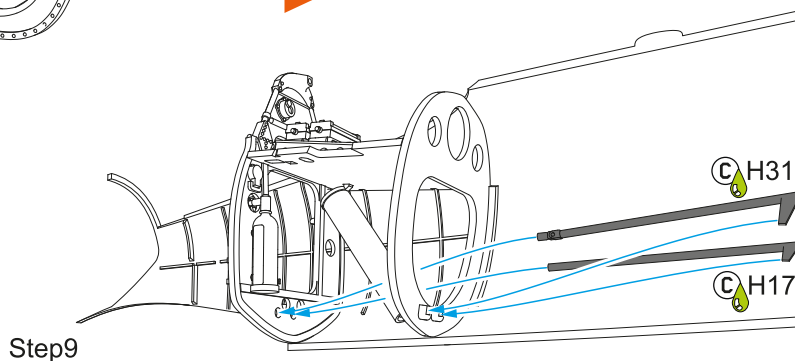
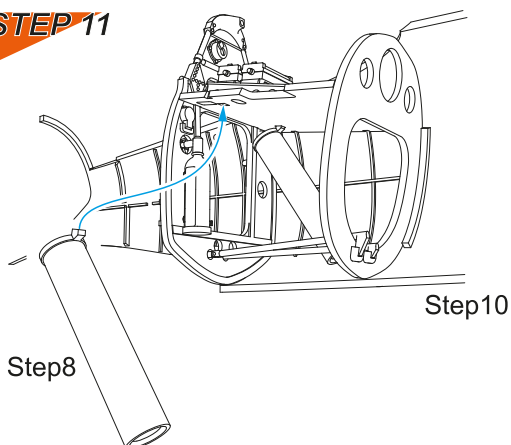
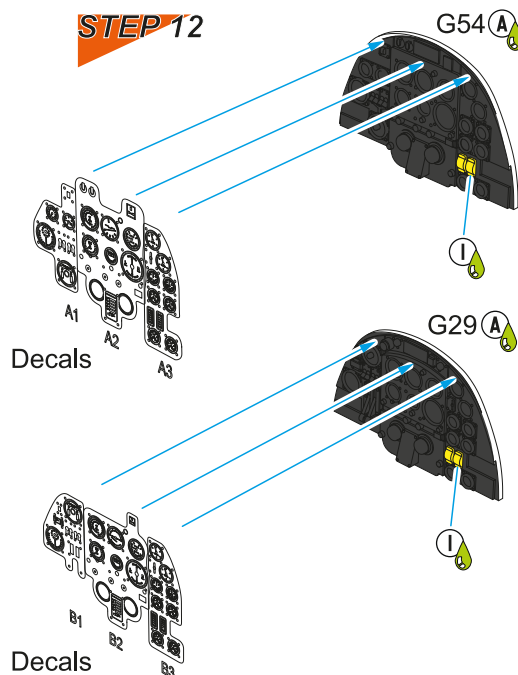
STEP 3**STEP 4****STEP 5 2x****STEP 6****STEP 7****STEP 8 2x****STEP 9****STEP 10****STEP 11****STEP 12**

Pro camo B (raná palubní deska), použijte díl G54, krok 16.

Scheme B (early instrument panel) - pt G54, step 16.

Pro camo A, C, D (pozdější palubní deska) použijte díl G29, krok 17.

Schemes A, C, D, (late instrument panel) - pt. G29, step 17.

STEP 13

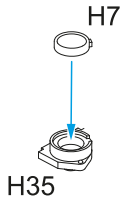

STEP 14

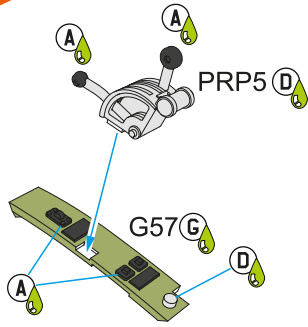

STEP 15

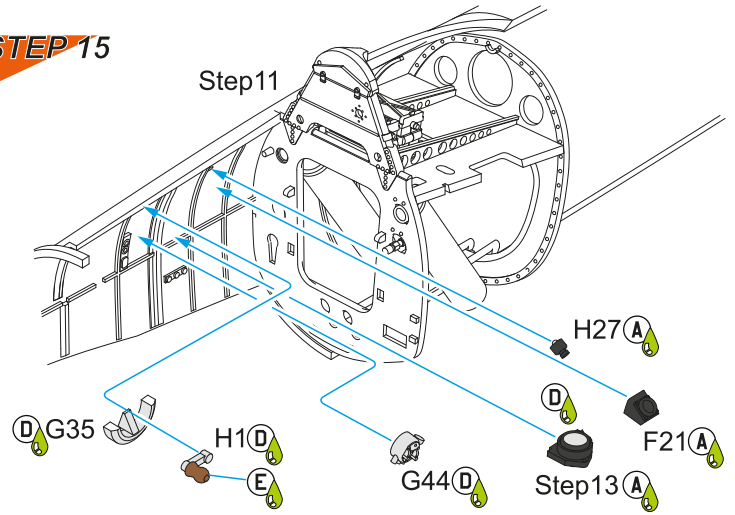

STEP 16

Scheme B

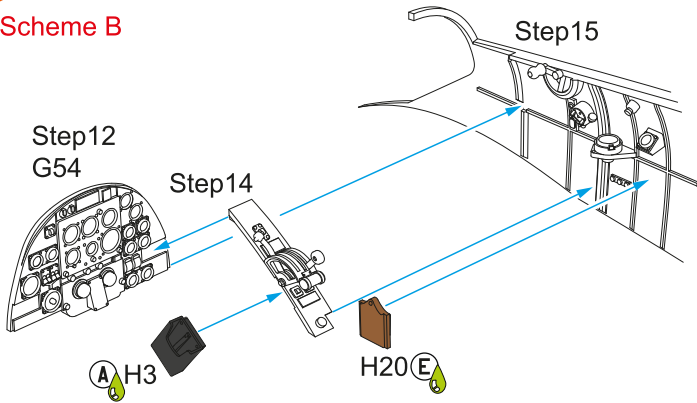

STEP 17

Scheme A, C, D

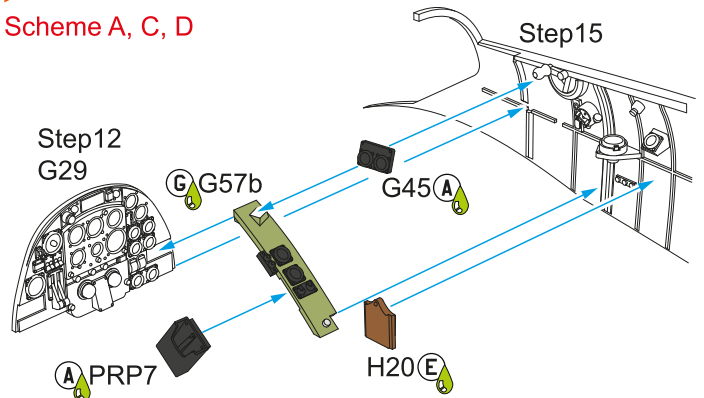

STEP 18

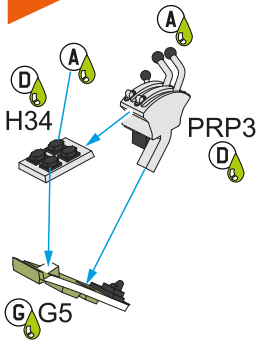

STEP 19

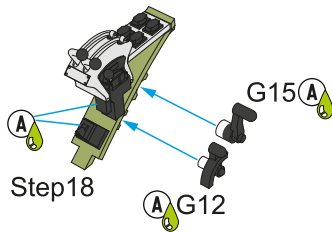

STEP 20

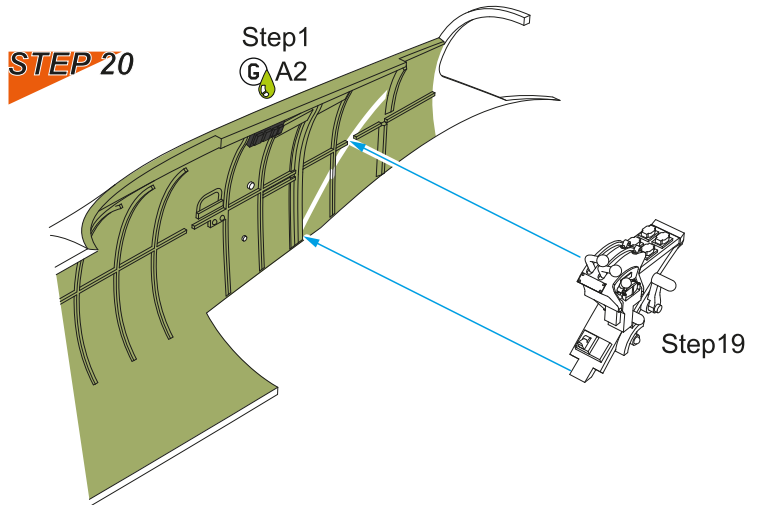

STEP 21

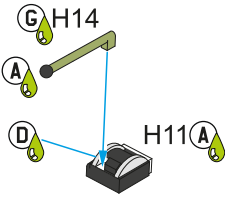

STEP 22

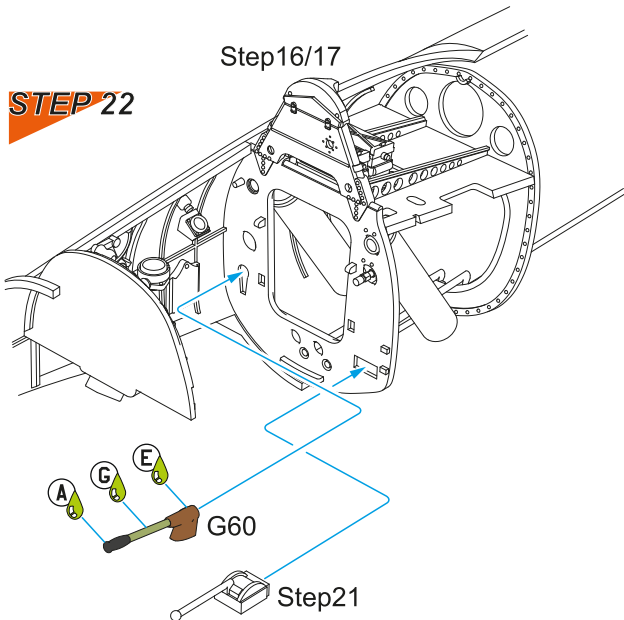

STEP 23

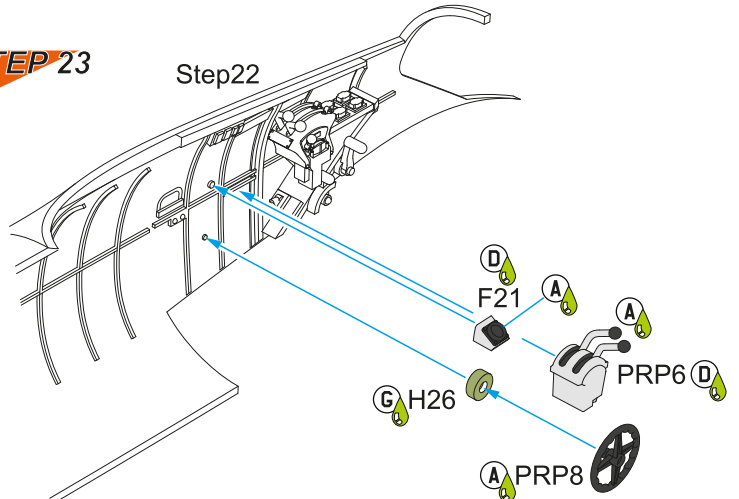

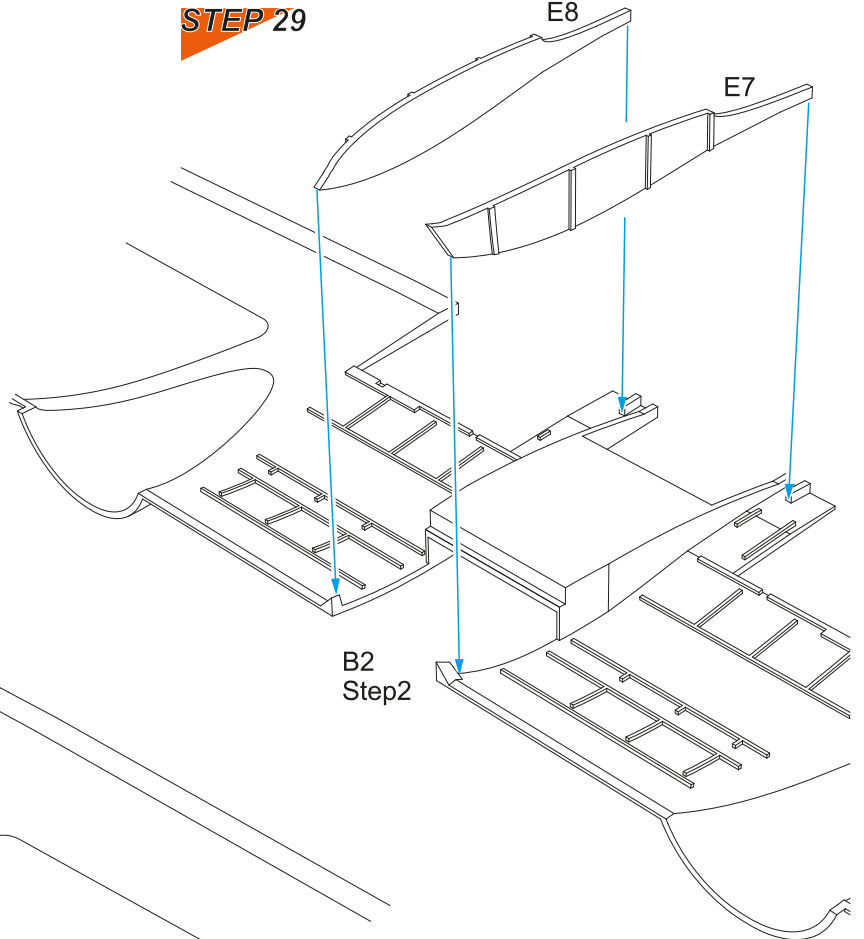
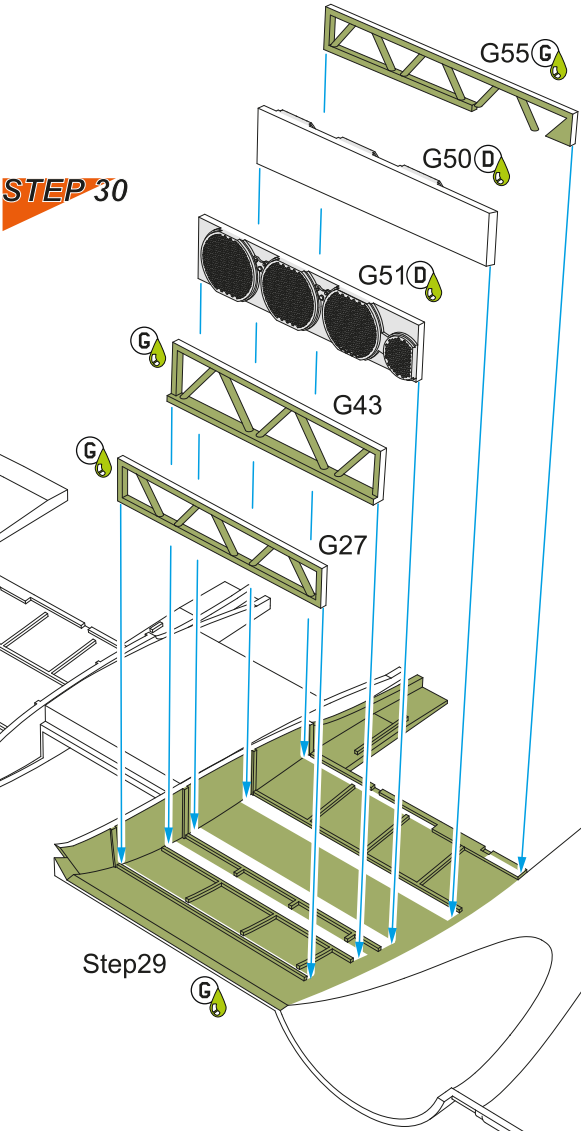
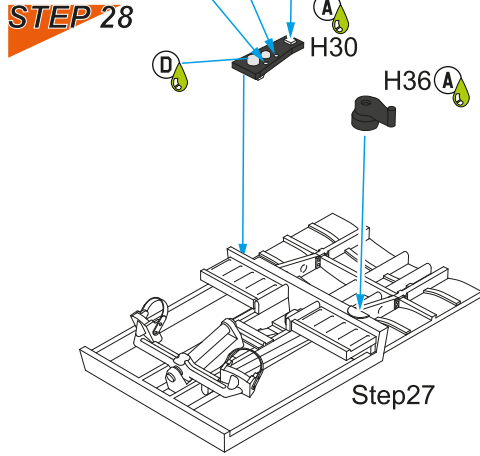
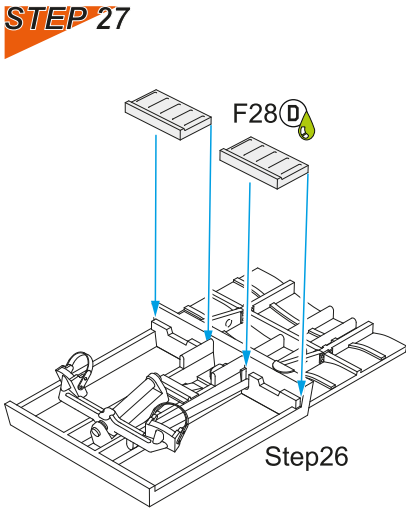
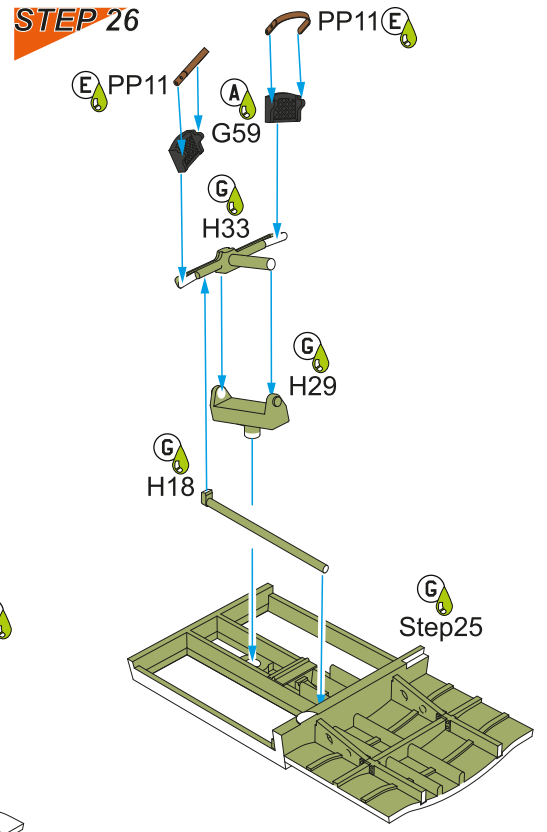
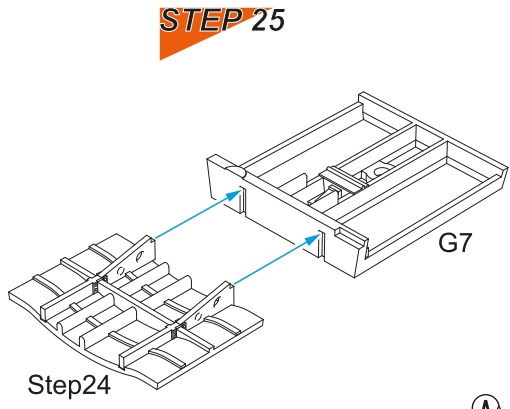
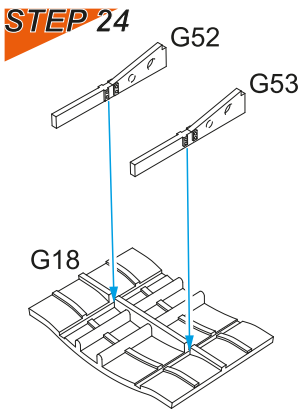

STEP 31

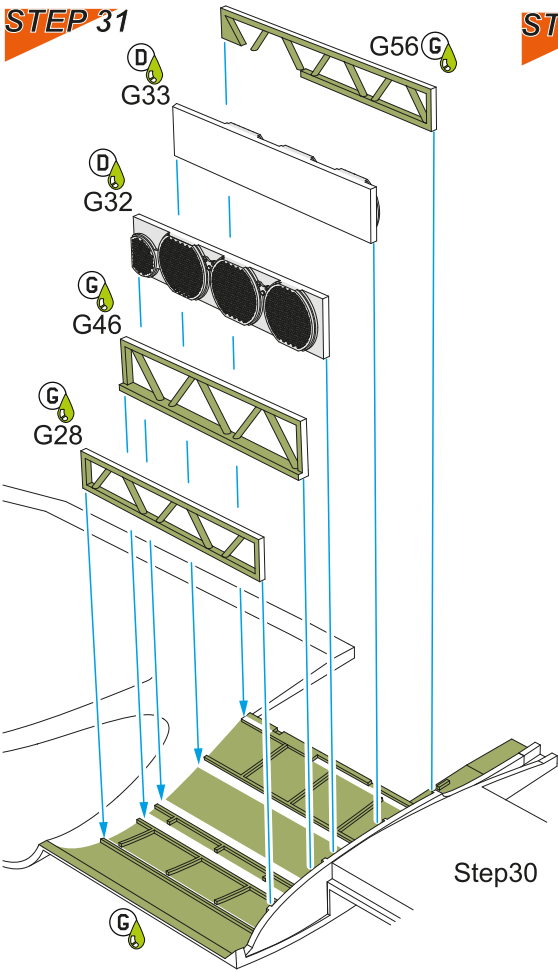

STEP 32

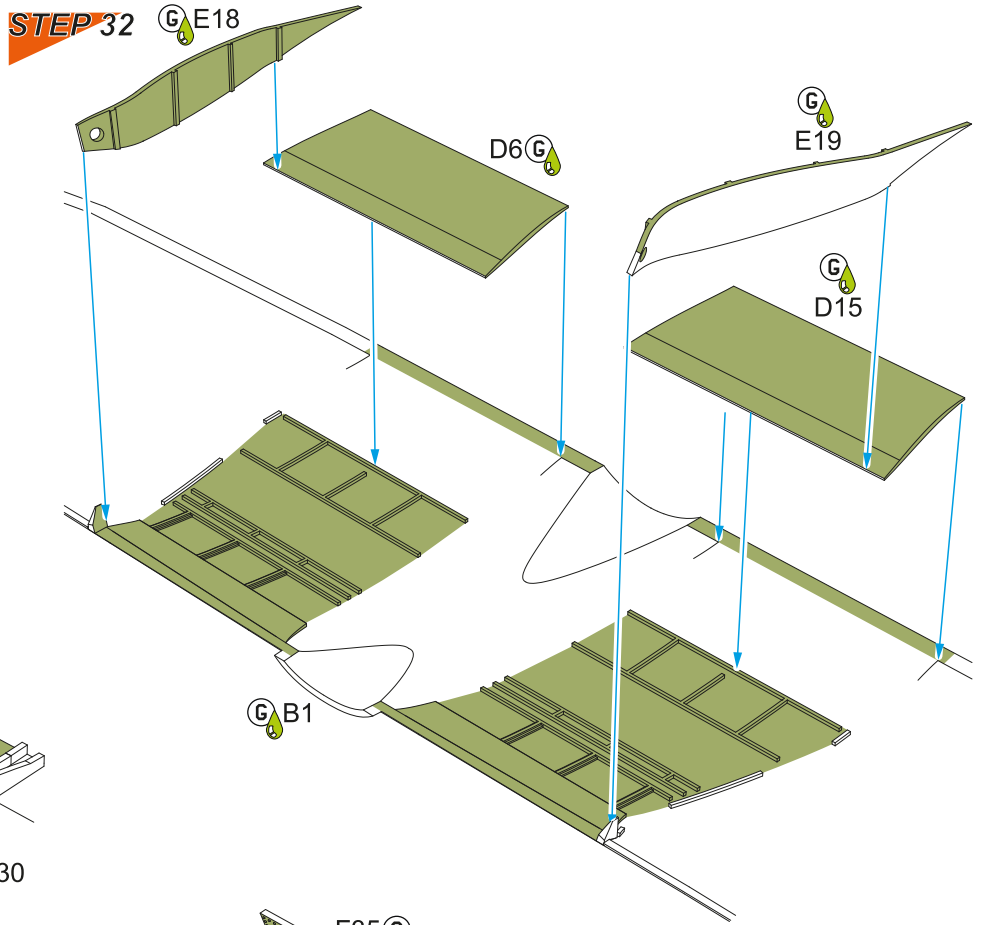

STEP 33

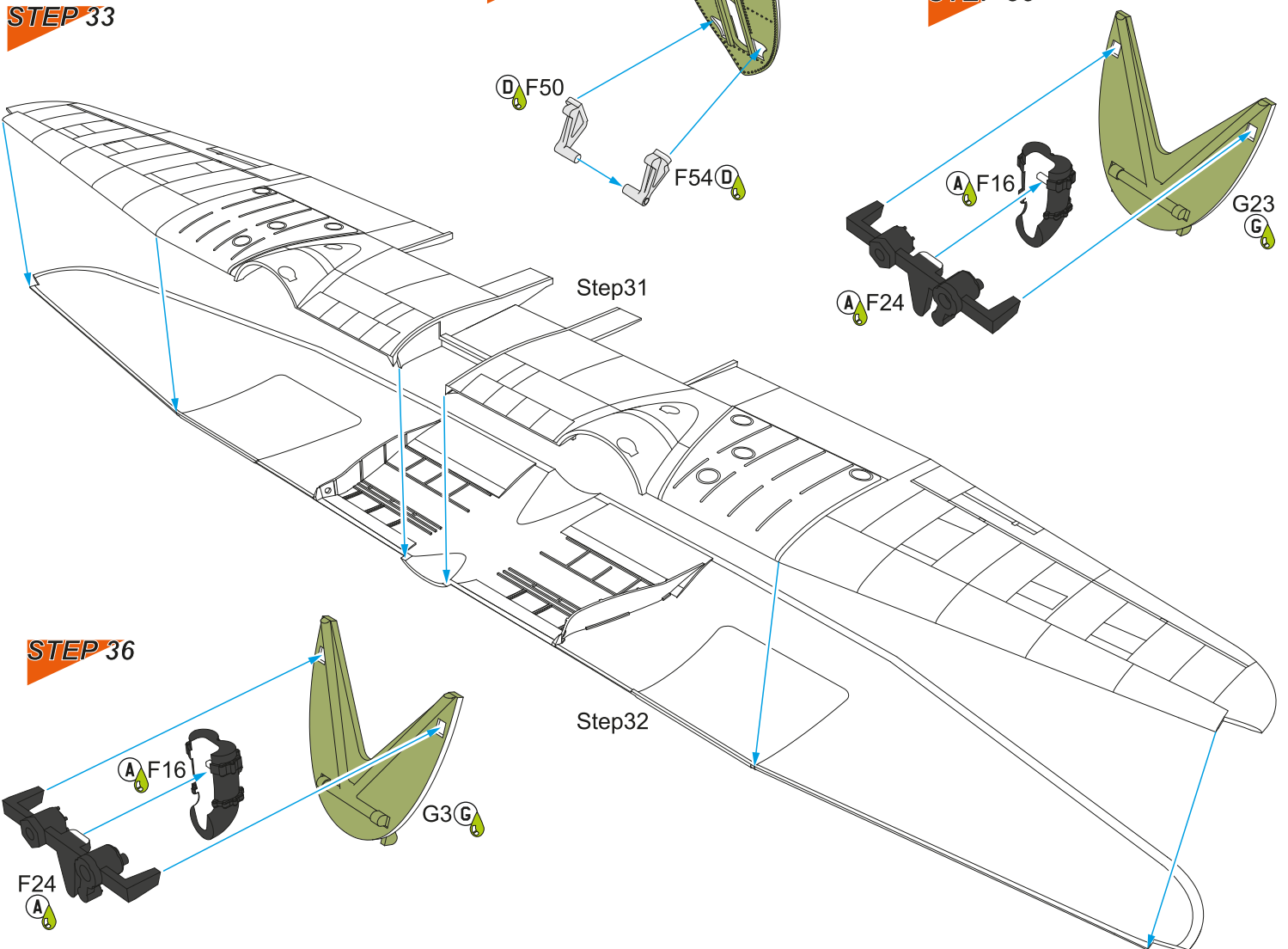

STEP 34 2x

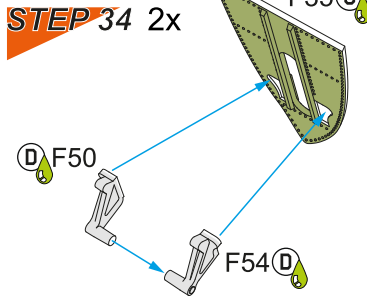

STEP 35

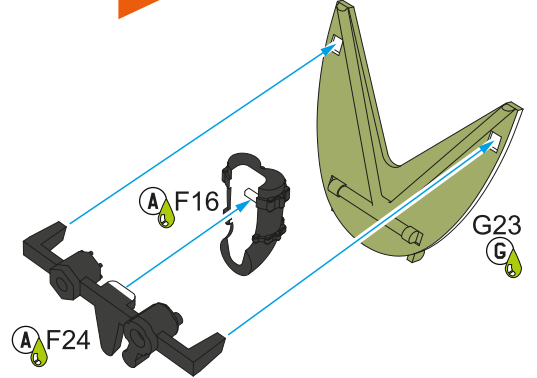

STEP 36

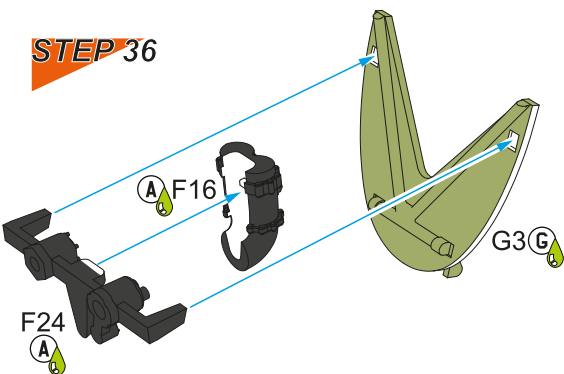

STEP 37 4x

C1/ 4/ 8/ 12

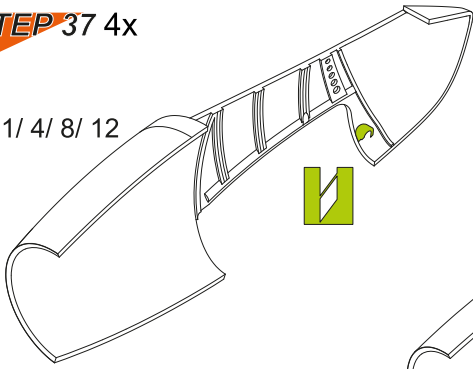

STEP 38

G1 (left engine)
G12 (right engine)

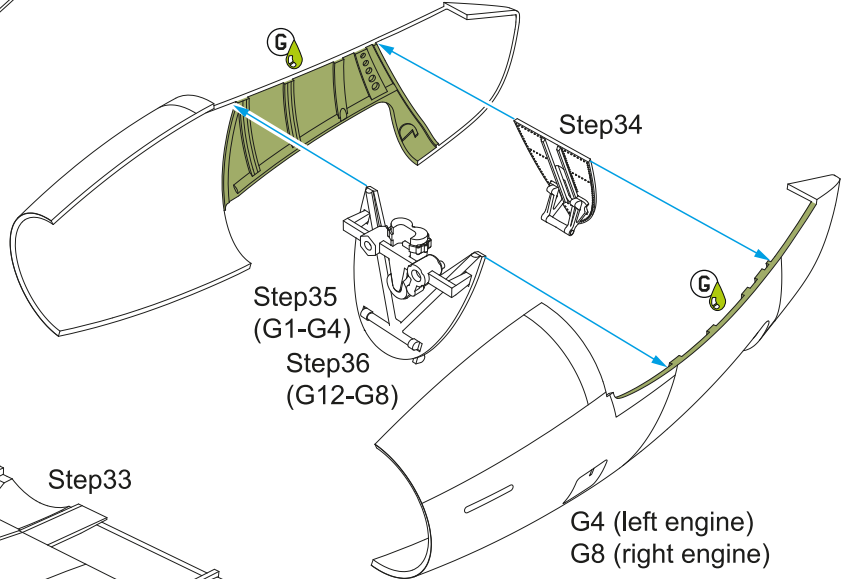

STEP 39

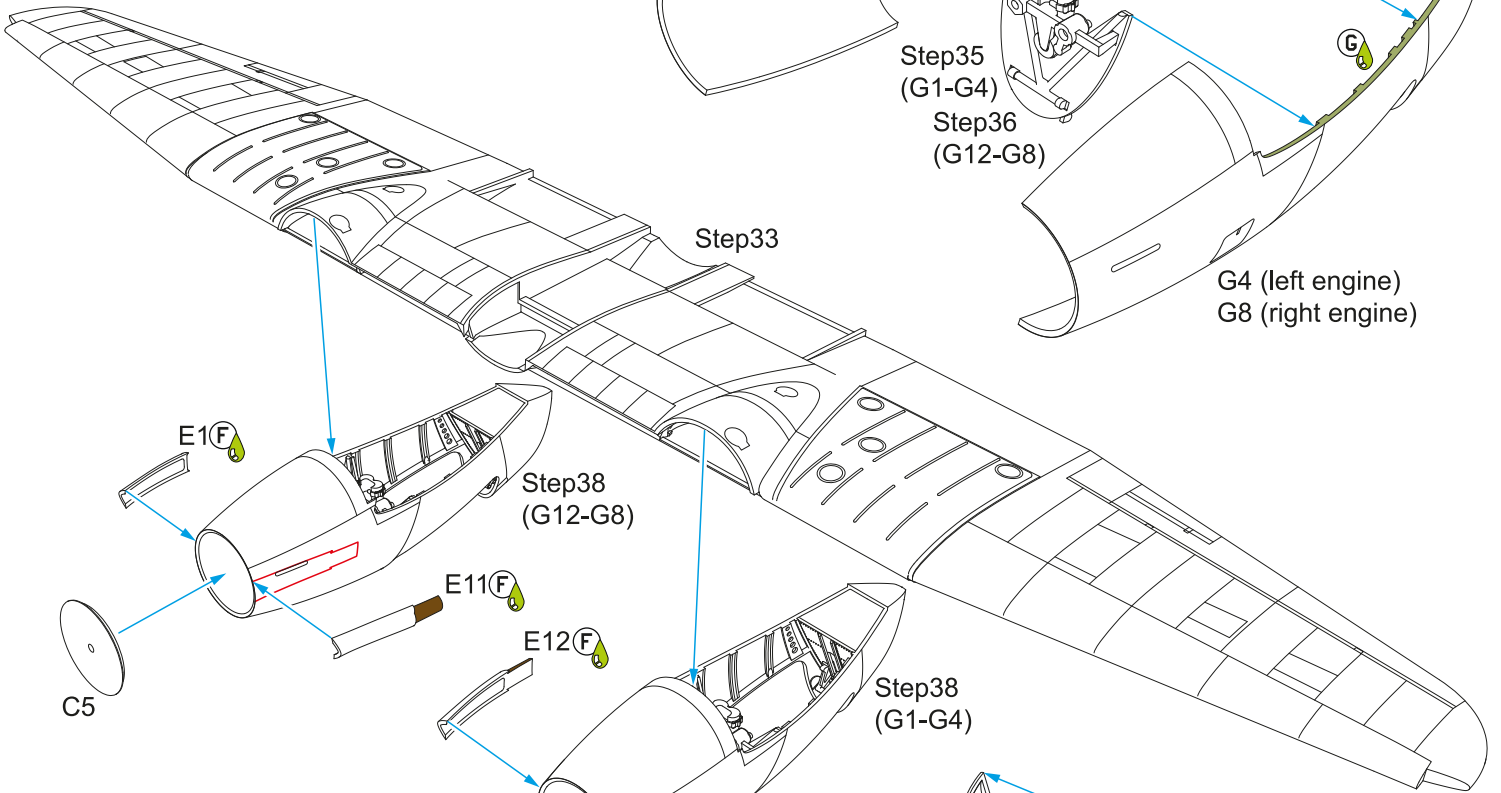

STEP 40

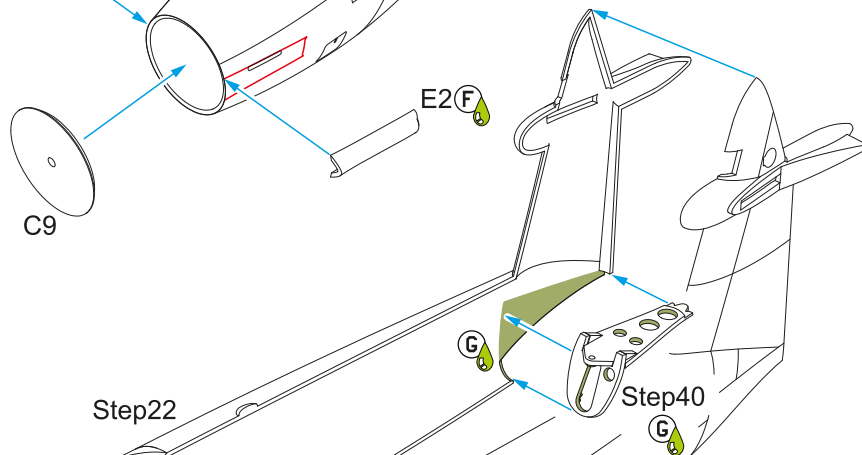
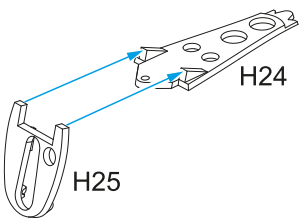

STEP 42

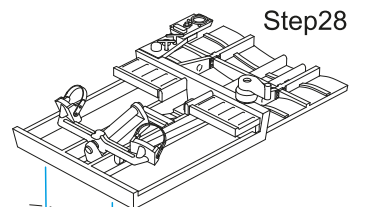

STEP 41

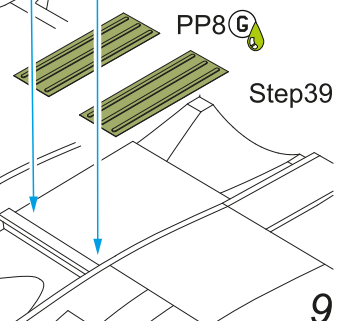
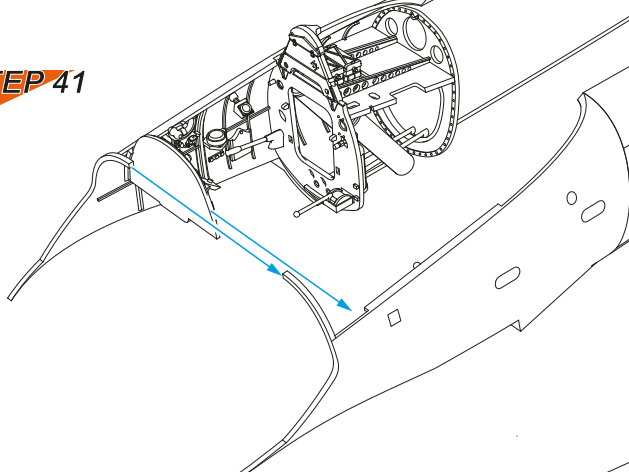

STEP 44

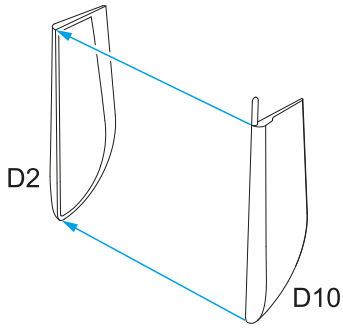

STEP 45

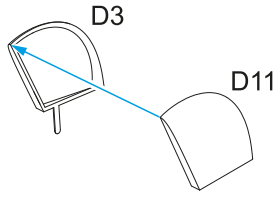

STEP 43

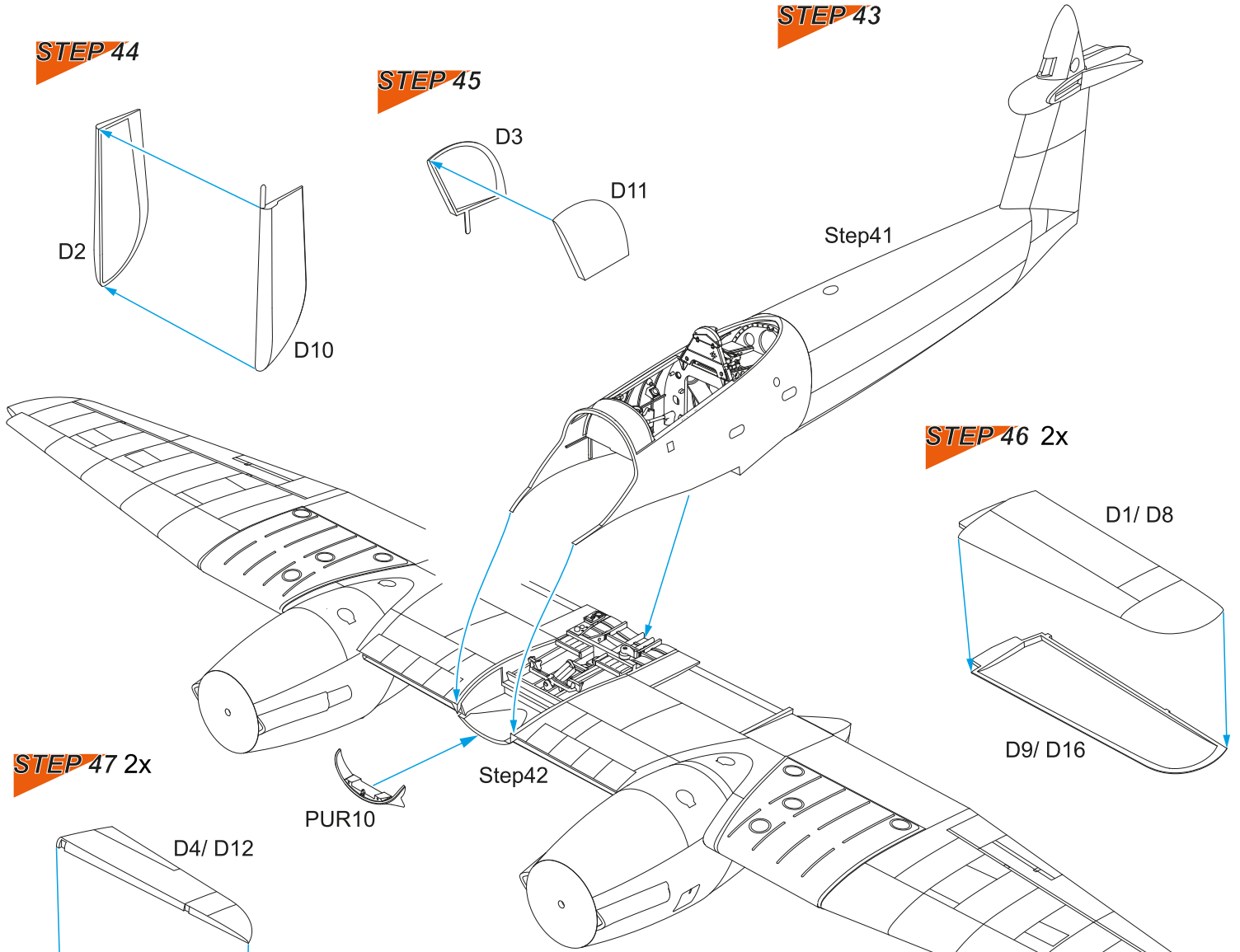

STEP 46 2x

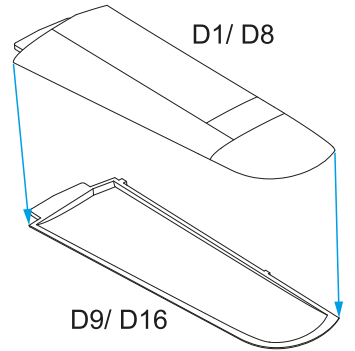

STEP 47 2x

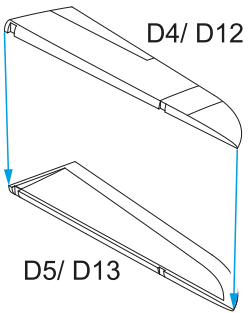

STEP 48

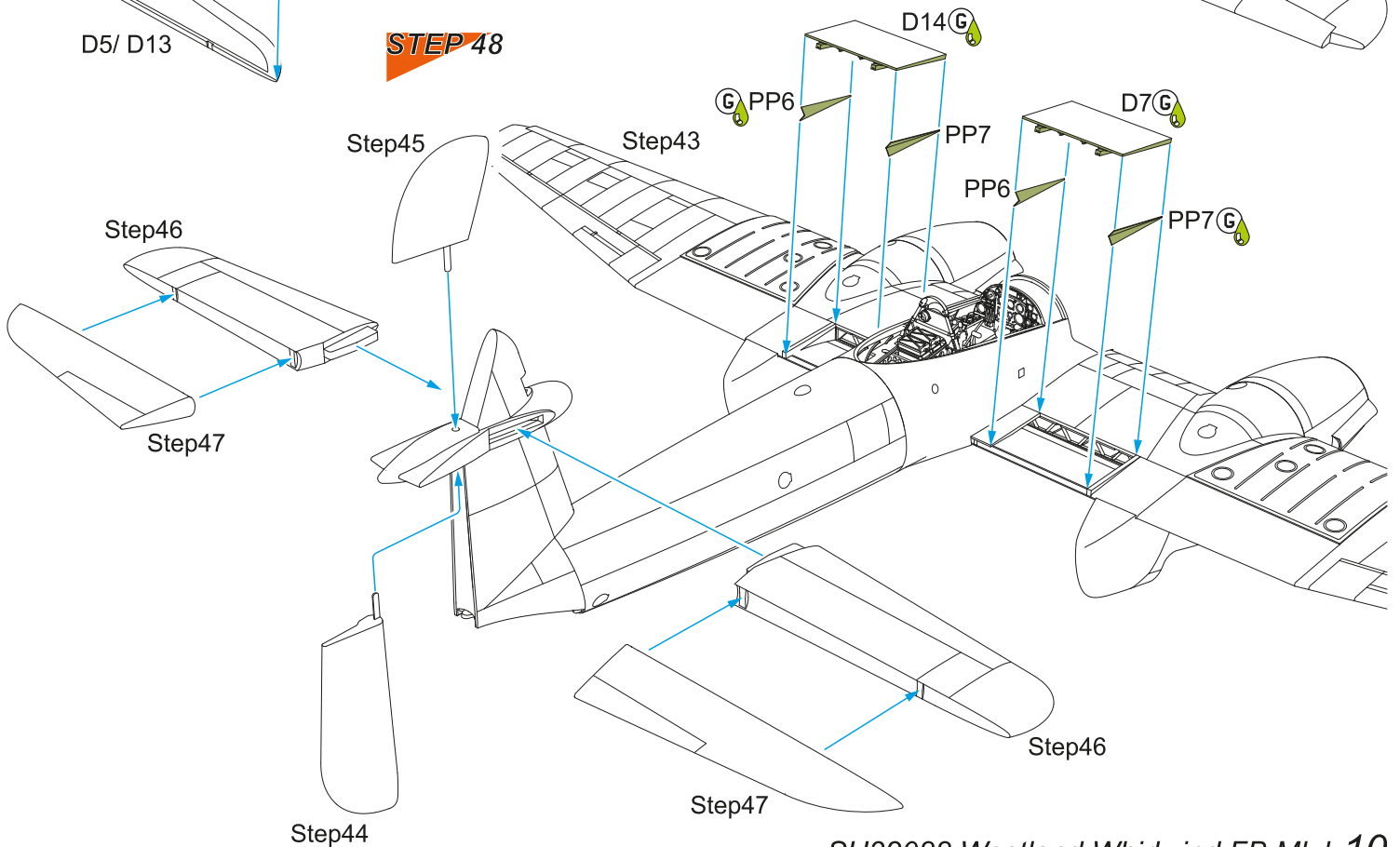

STEP 49

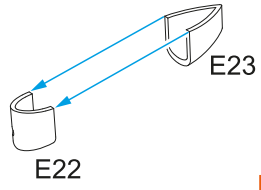

STEP 50

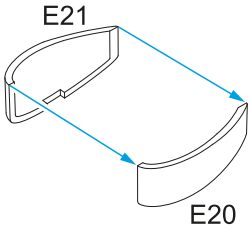

STEP 51

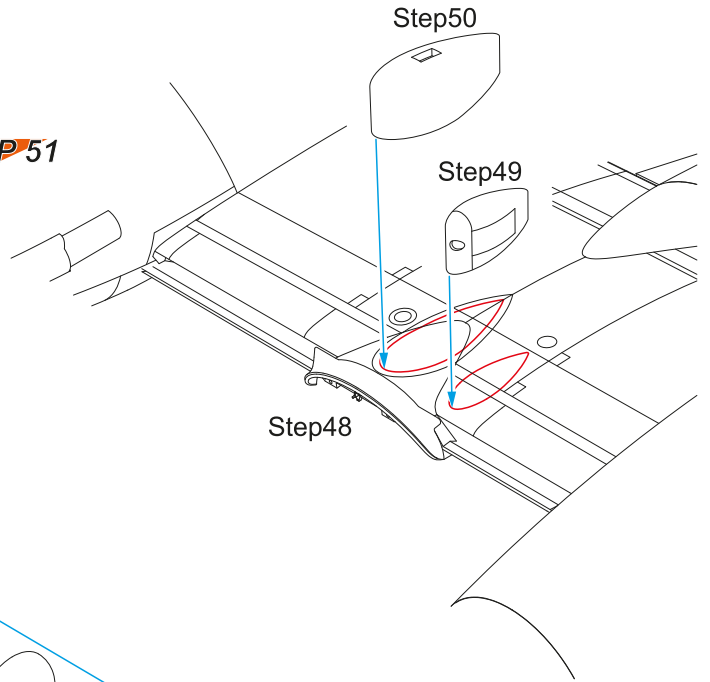

STEP 52

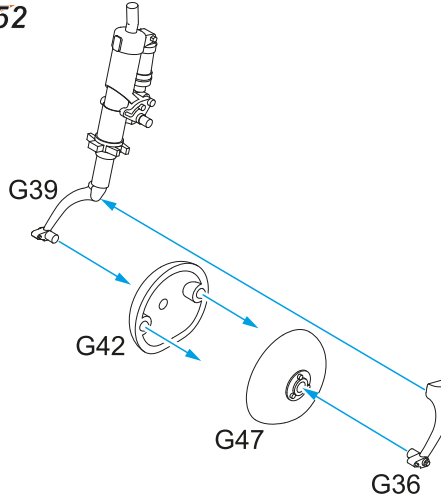

STEP 53

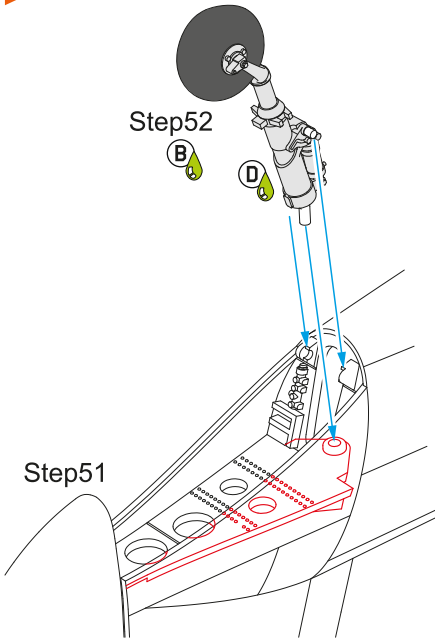

STEP 54

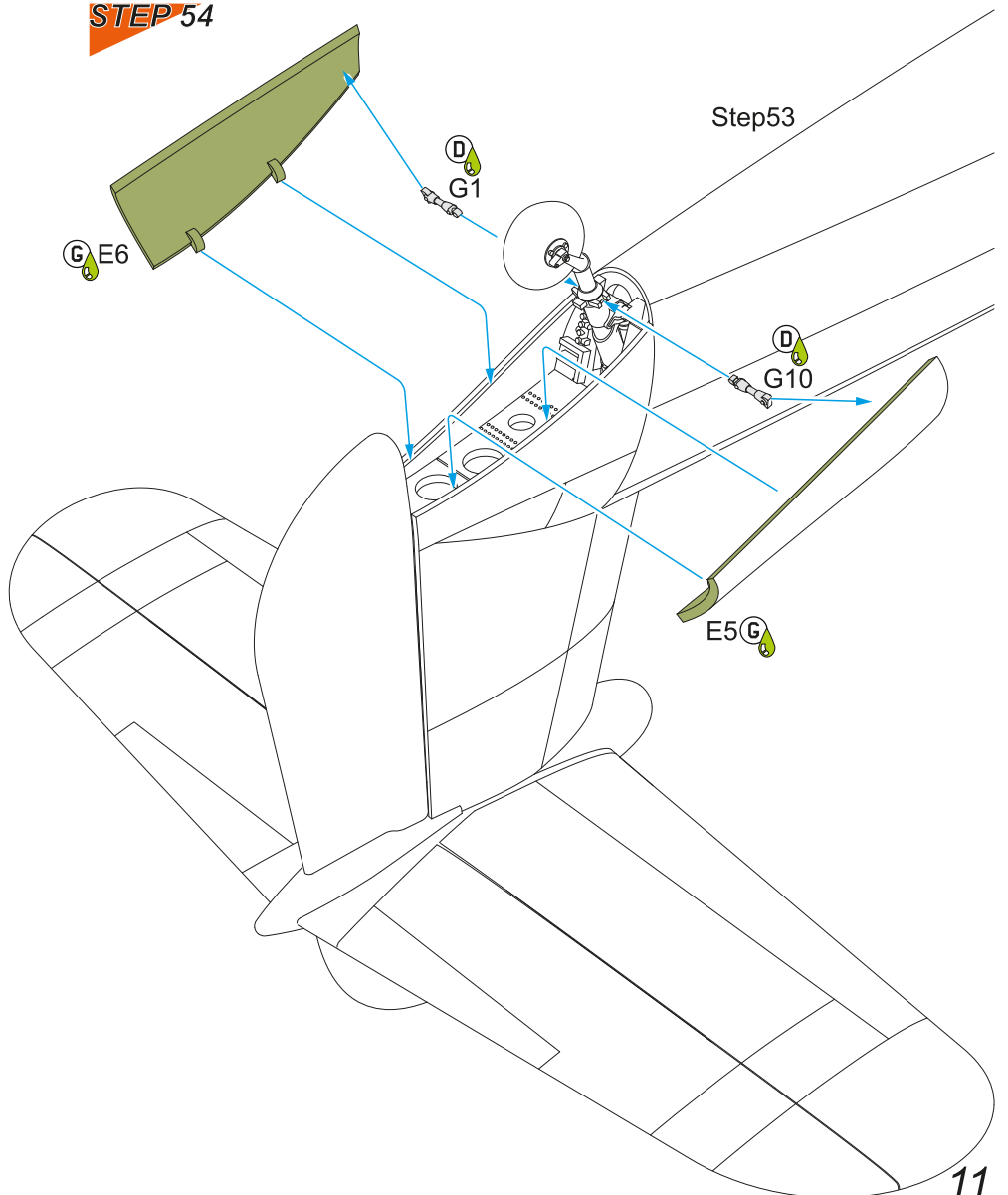

STEP 55 2x

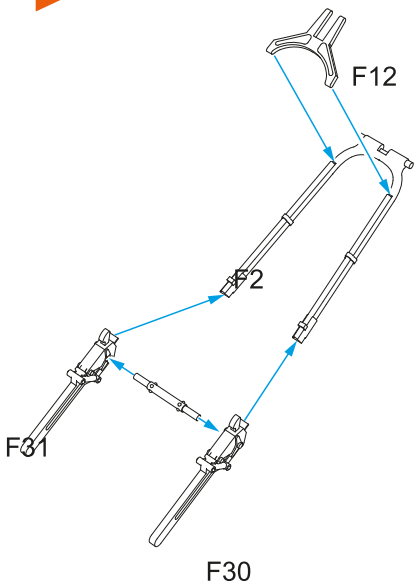

STEP 56

Both sides

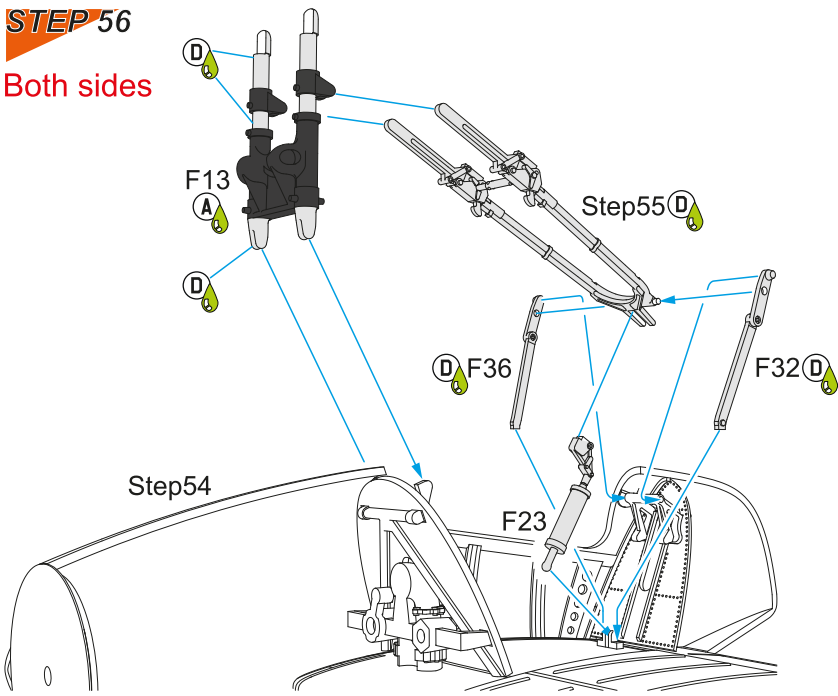

STEP 57 2x

STEP 58

Both sides

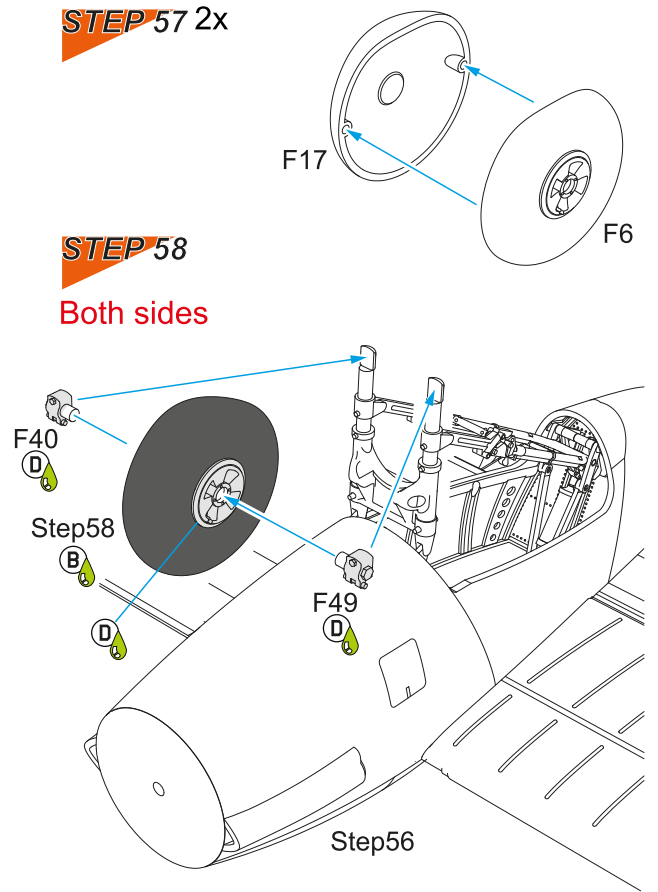

STEP 59

Both sides

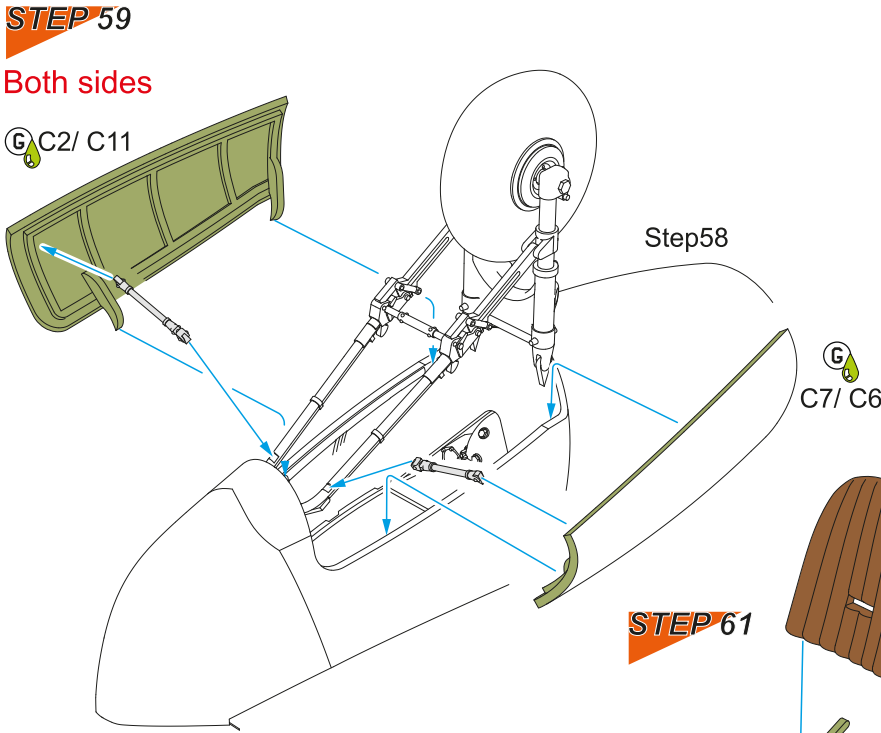

STEP 60

STEP 62

STEP 65

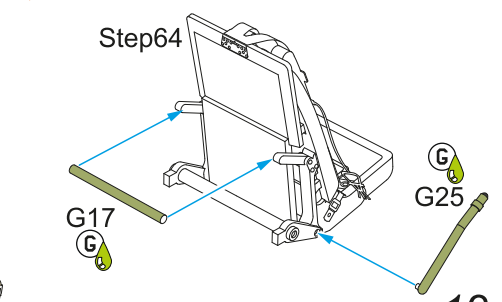
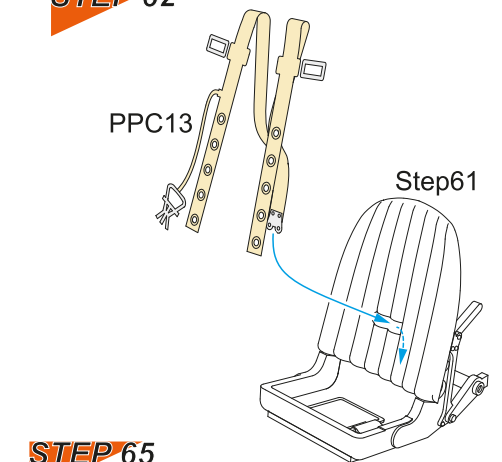
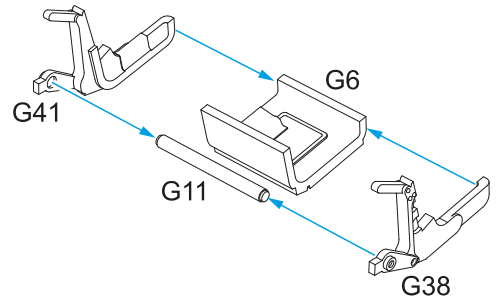

STEP 63

STEP 64

STEP 61

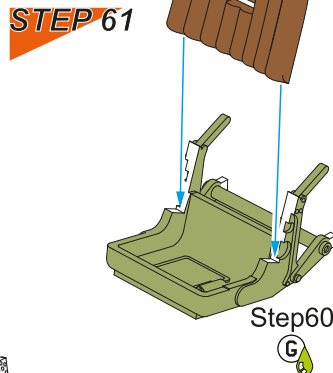
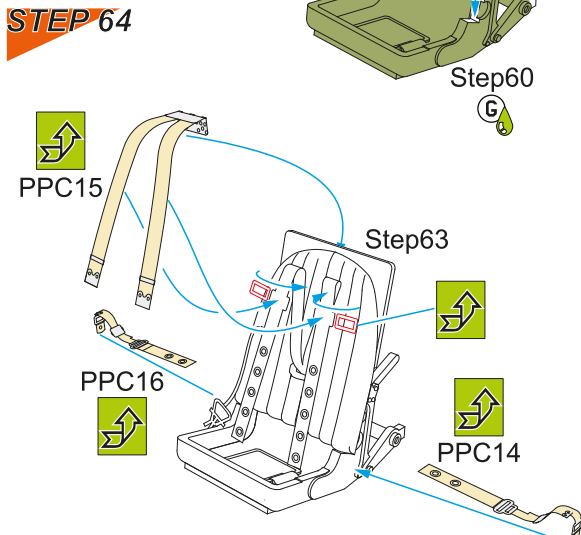
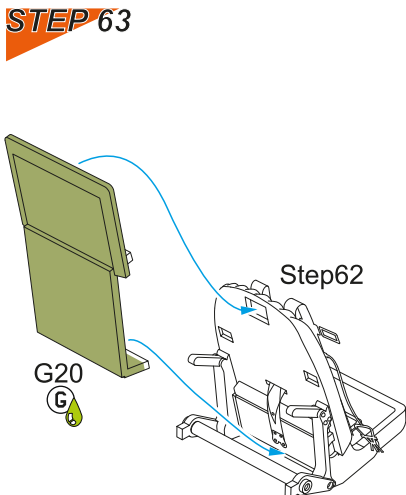

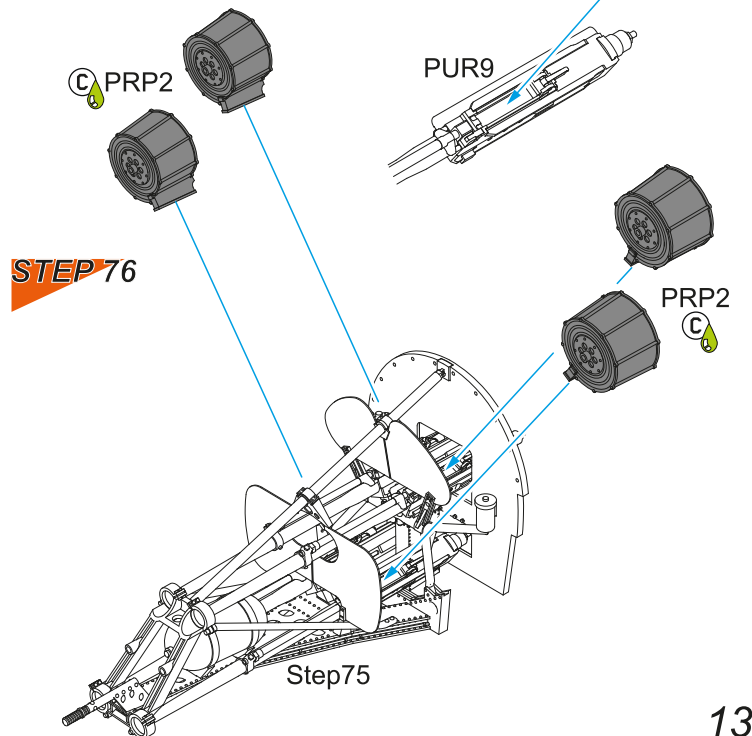
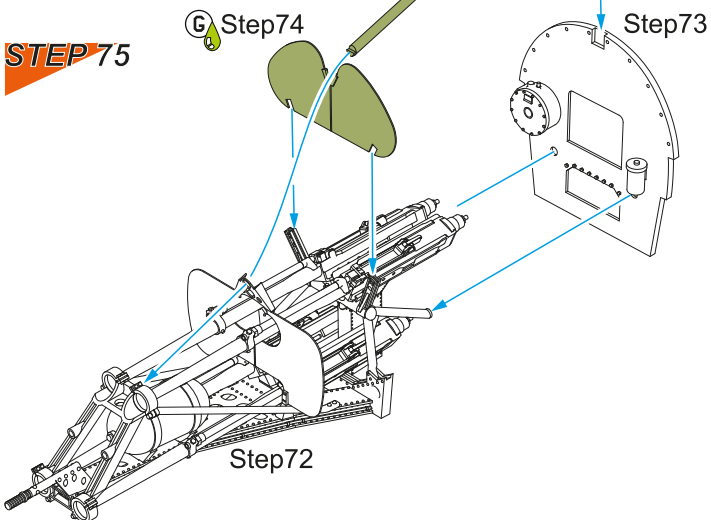
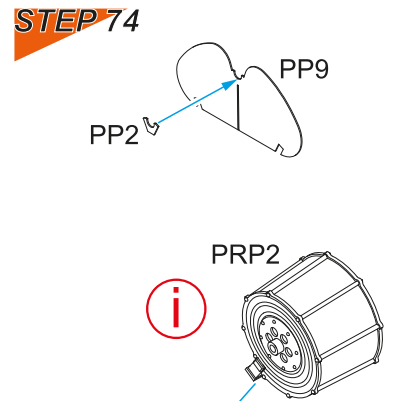
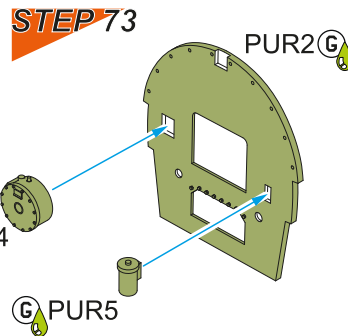
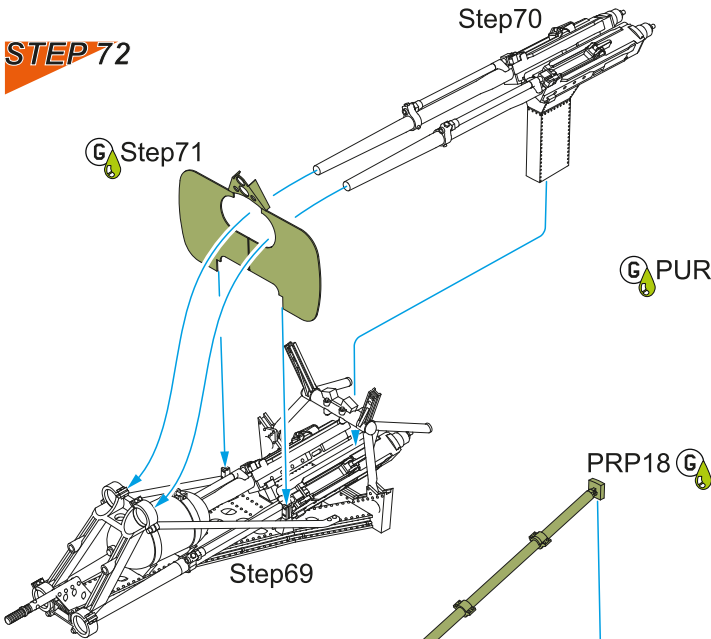
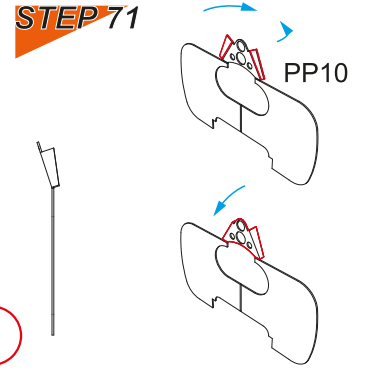
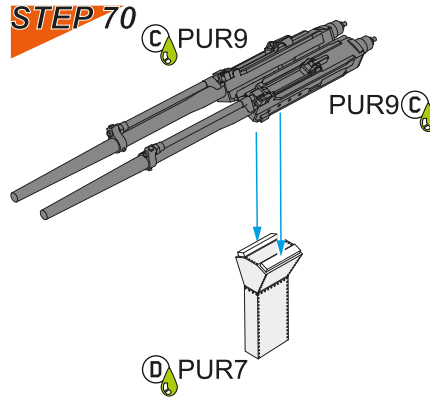
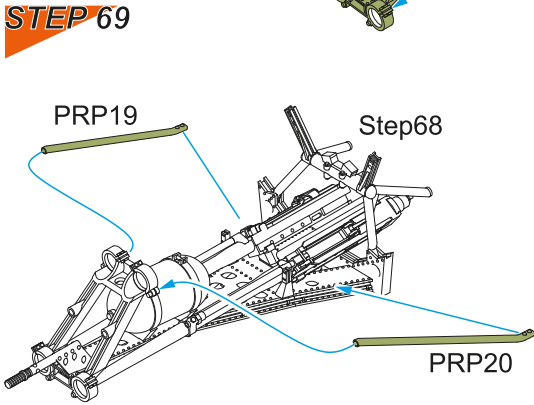
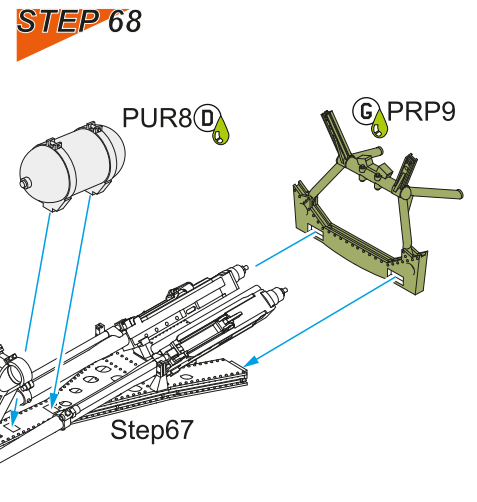
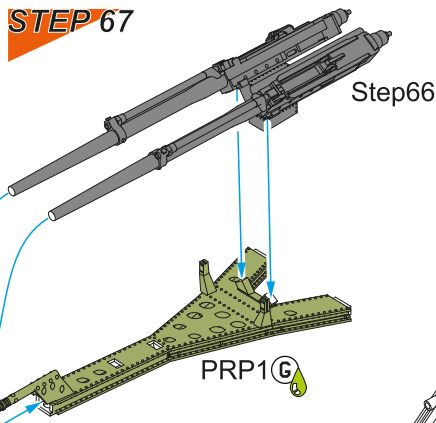
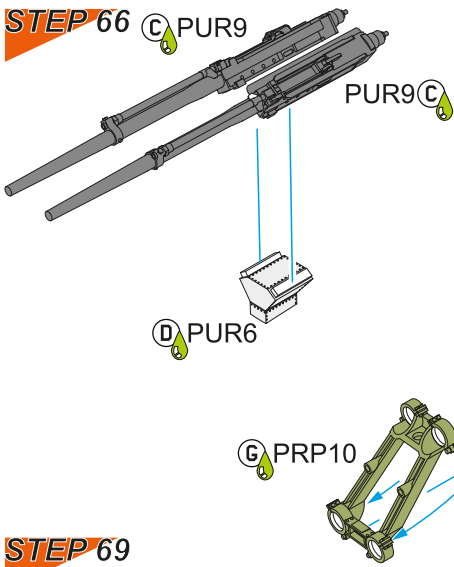



STEP 77

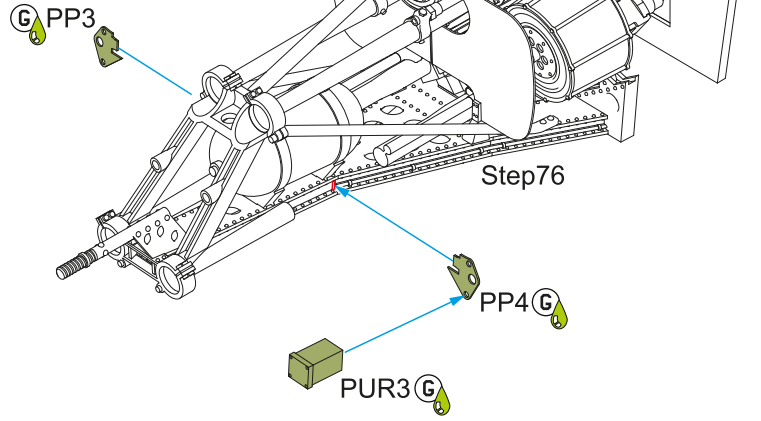
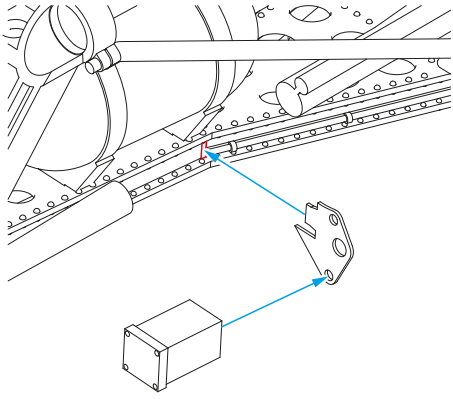

STEP 78

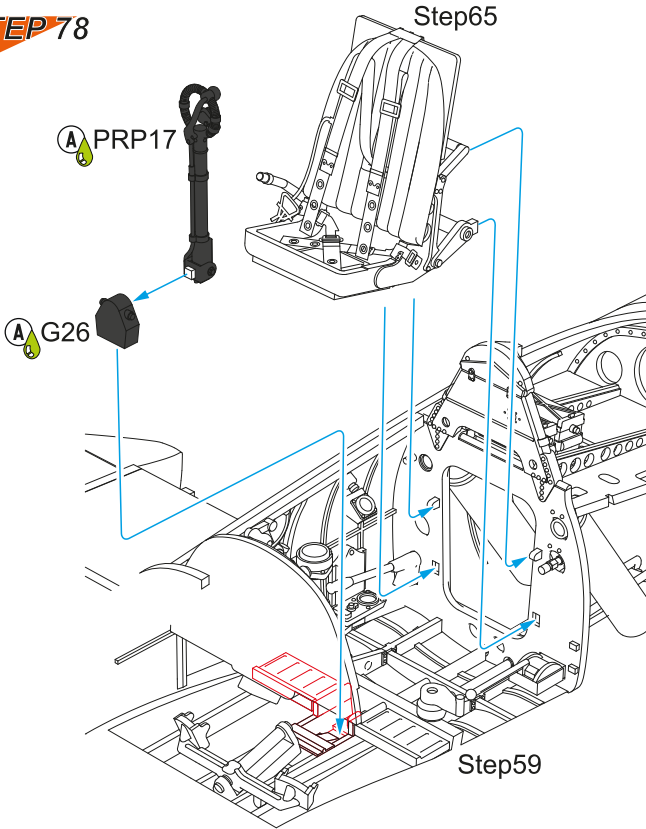

STEP 79

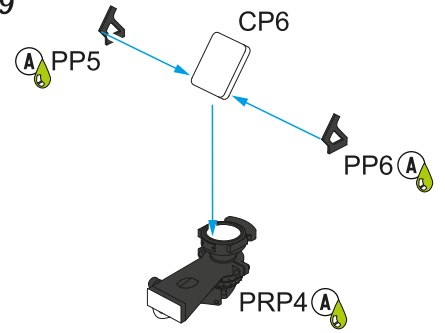

STEP 80

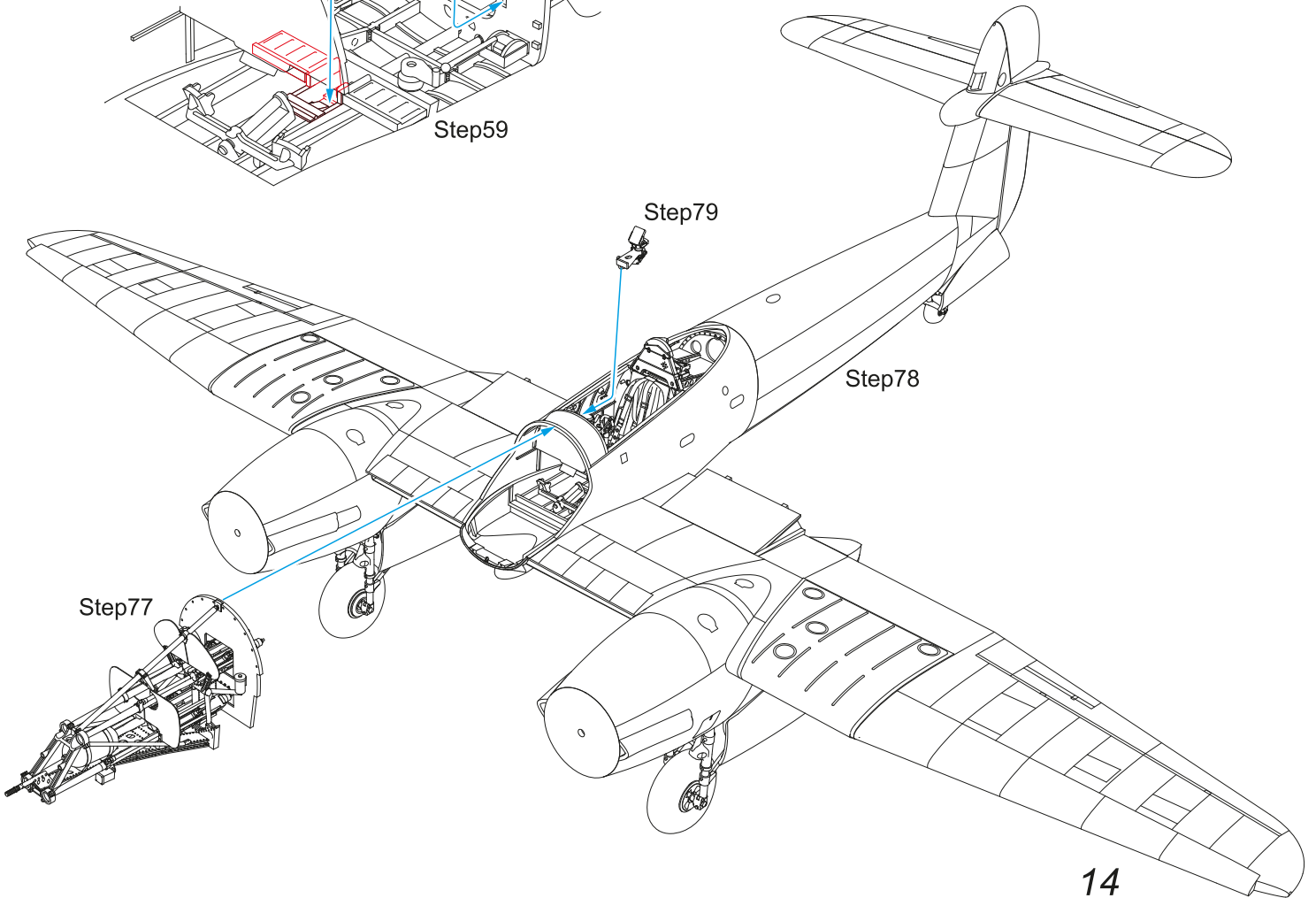

STEP 81

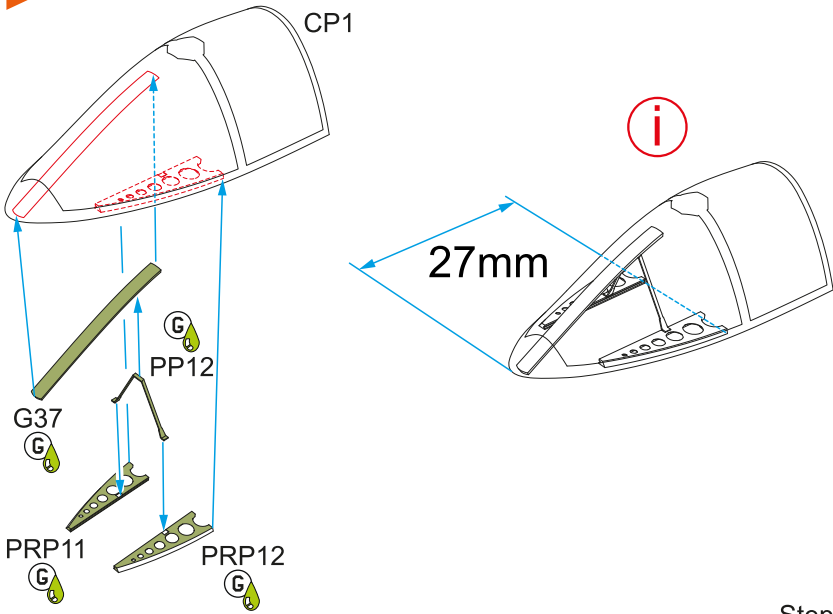

STEP 82 2x

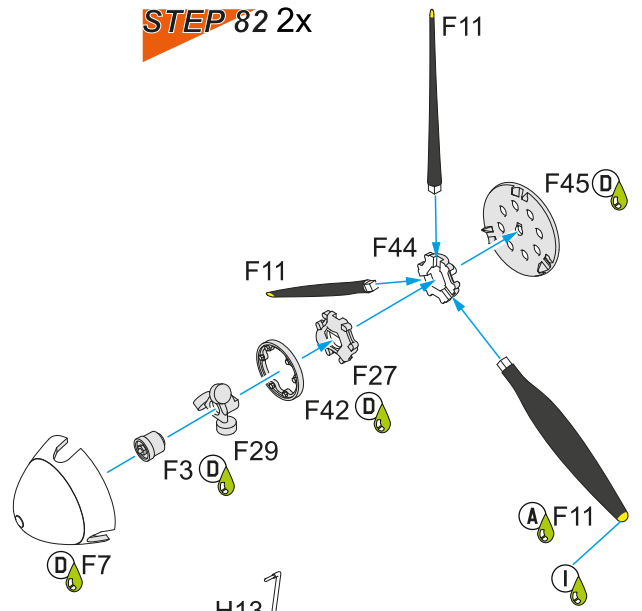

STEP 83

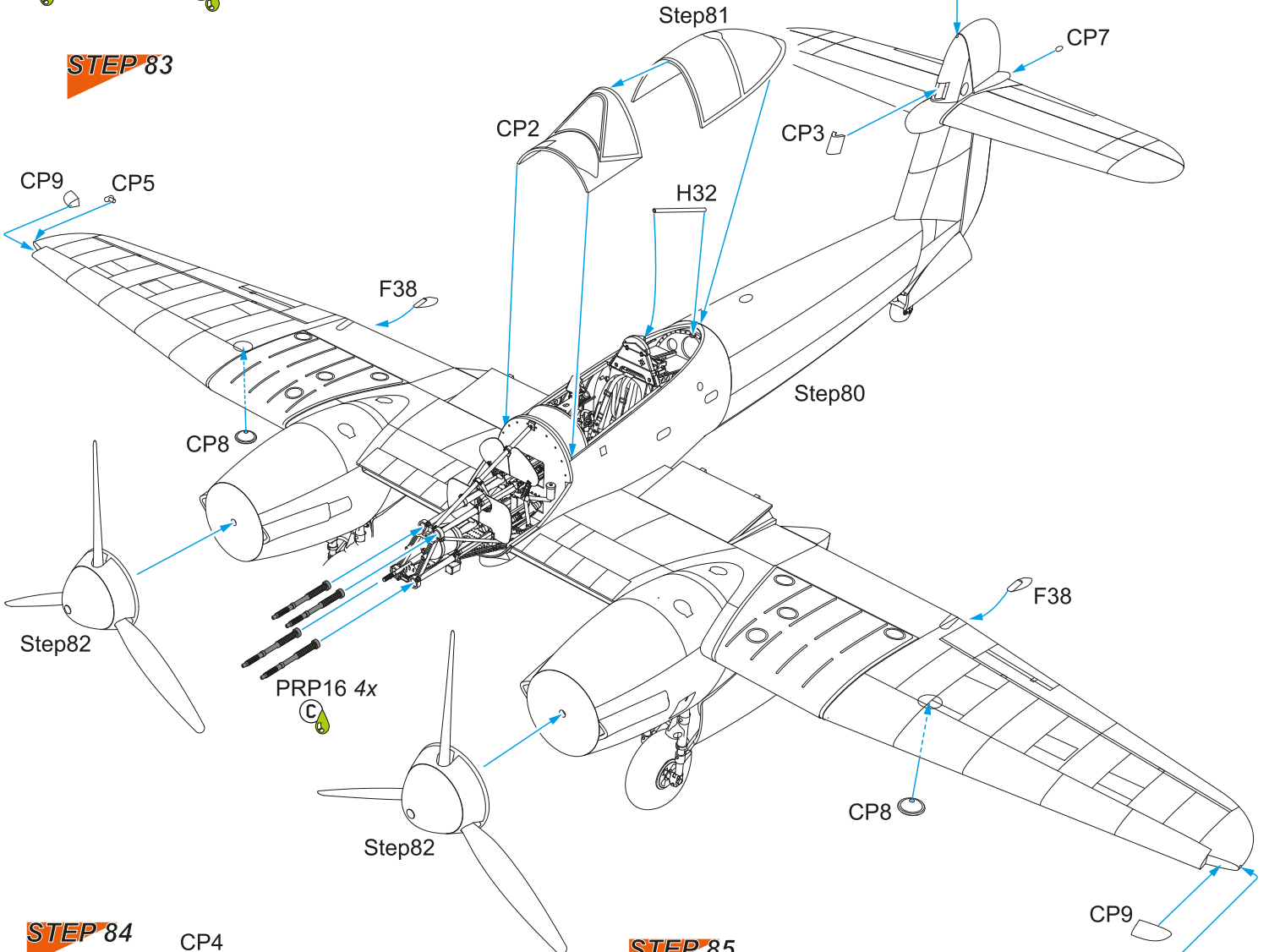

STEP 84

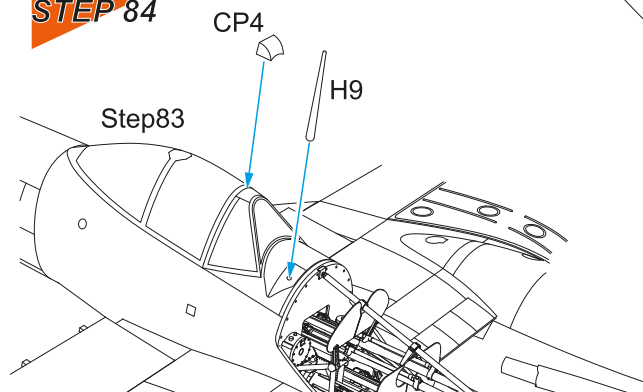

STEP 85

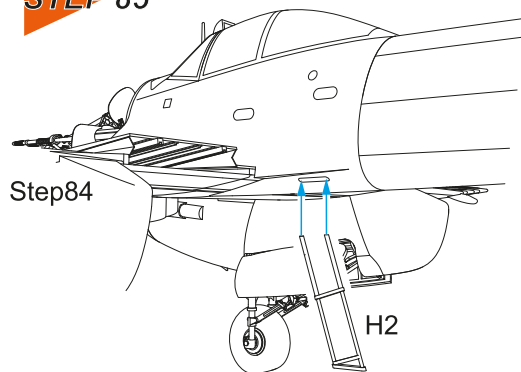

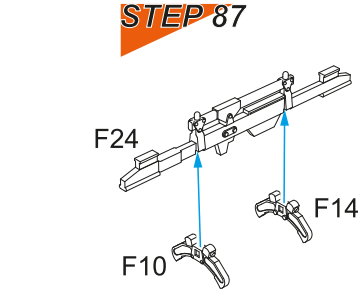
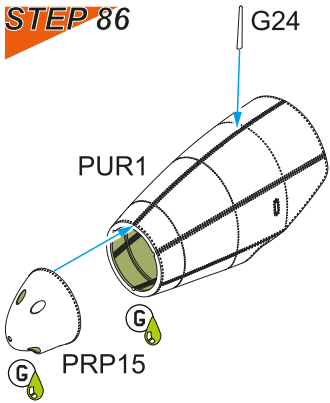

STEP 91

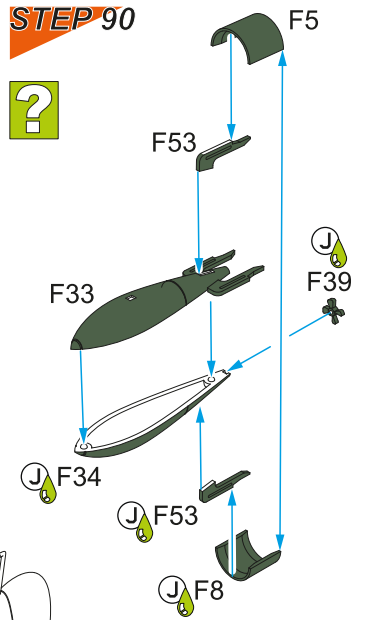
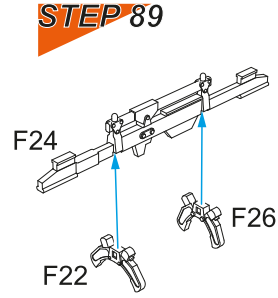
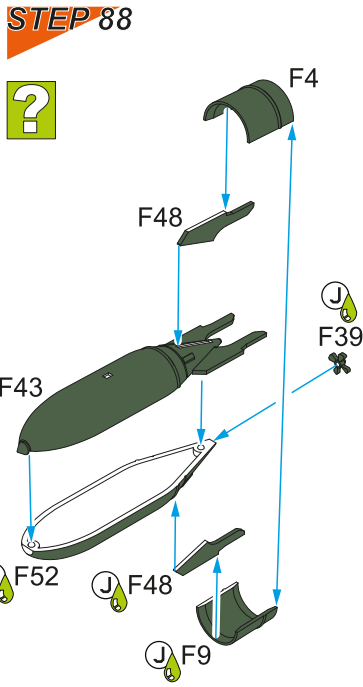
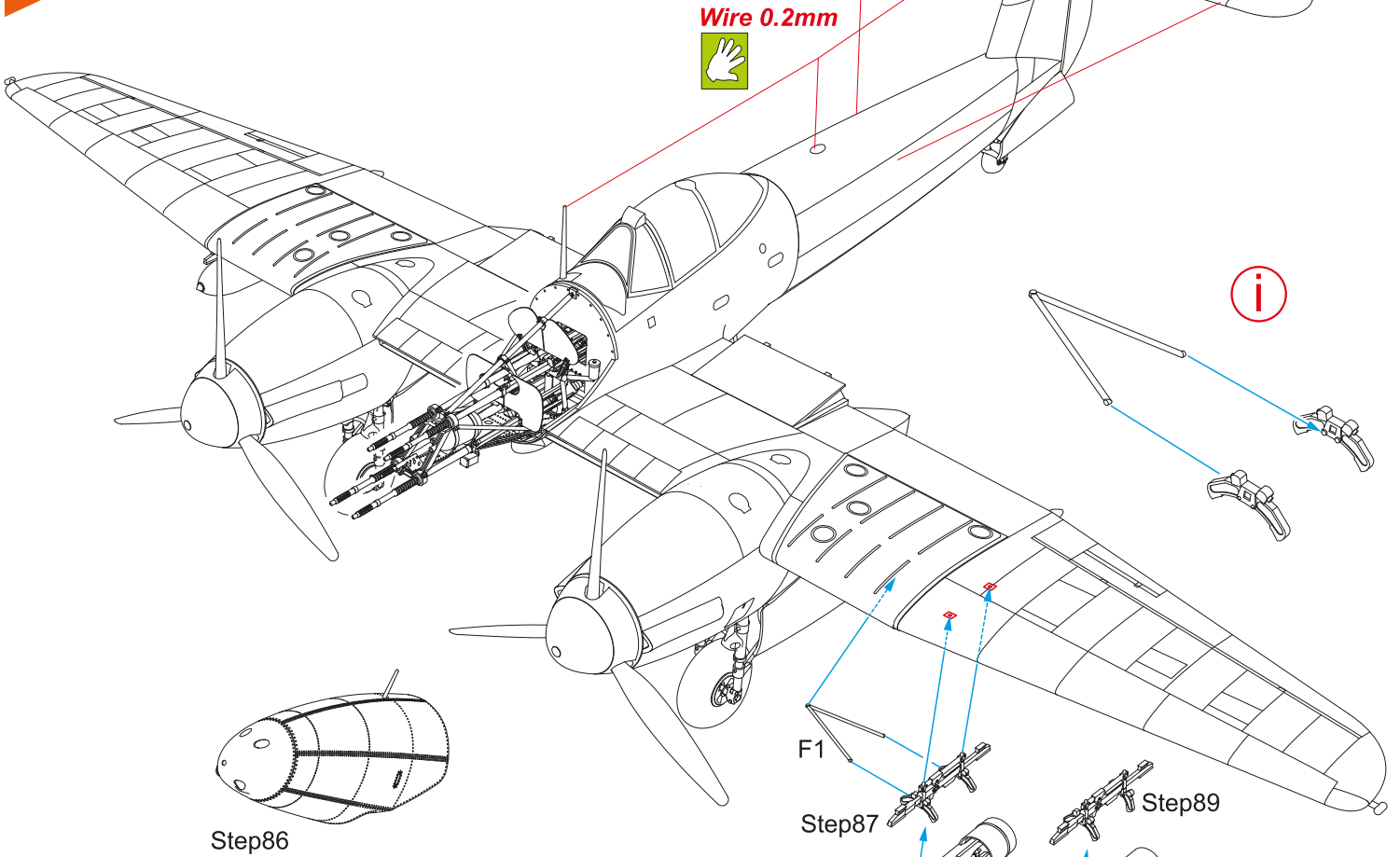

Step86

Need a pilot for your 1/32 Whirlwind?



We recommend F32381 RAF Whirlwind Fighter Pilot (1942). Excellent cast figure contains P-E parts.

Both sides

Special Hobby offers great resin and 3D printed sets under the CMK brand

all at www.specialhobby.eu

Westland Whirlwind FB Mk.I, P7094, HE-T, "Bellows", No.263 Squadron RAF, Warmwell airfield, beginning of 1943. Except the presentation writing below the canopy there's a pilot's name F/Lt Blackshaw on the port side in the brown rectangle of the original Dark Earth color. Canadian pilot F/O J. P. Coyne was photographed in the cockpit of this machine. The upper surface camouflage consists of three colors. Except of the Dark Green and Mixed Grey also Ocean Grey was used. The propeller spinners as so the tail fairing sport miniaturized national insignias. It is highly probable that this machine on March 28, 1943 participated in Roadstead 60 mission the attack on German convoy in La Manche channel. During this mission the Whirlbombers were escorted by Spitfires from No.310 (Czechoslovak) and No. 313 (Czechoslovak) RAF Squadrons. The aircraft was destroyed on May 16, 1943 with 166 hours of flight time assigned subsequently to No. 263, No. 137 and back with No. 263 RAF Squadrons.

Westland Whirlwind FB Mk.I, P7094, HE-T, „Bellows“, No.263 Squadron RAF, letiště Warmwell, začátek roku 1943. Kromě nápisu pod kabinou je na levé straně uvedeno jméno pilota F/Lt Blackshaw v hnědém obdélníku původní kamuflážní barvy Dark Earth. V kabině tohoto letounu se ale nechal fotit kanadský pilot F/O J. P. Coyne. Kamufláž horních ploch se skládá ze tří barev, kromě Dark Green a Mixed Grey ještě z Ocean Grey. Vrtulové kužely jsou ozdobeny miniaturami znaků. Stroj se s velkou pravděpodobností 28.3.43 zúčastnil akce Roadstead 60, útoku na německý konvoj v kanálu La Manche. Při této akci byly „Whirlbombery“ doprovázeny Spitfiry od No.310 (Českoslovak) a 313. (Českoslovak) Squadron RAF. Letoun byl zničen 16. května 1943 po nalétaných 166 hodinách, kterých dosáhl postupně u No.263, No.137 a opět u No. 263 Squadron RAF.

Camo A

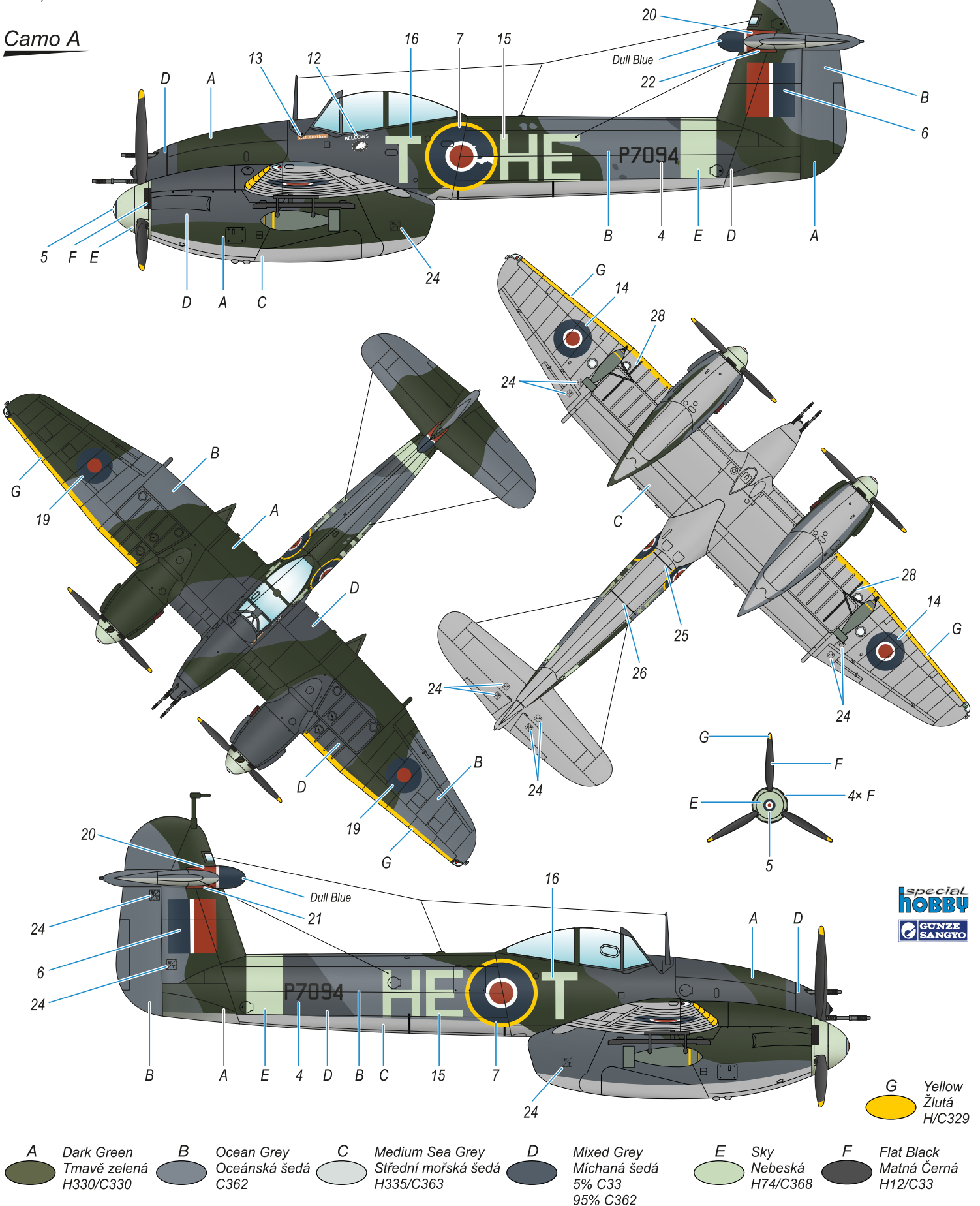

Westland Whirlwind FB Mk.I, P6974, HE-M, No.263 Squadron RAF, Angle airfield, July or August 1942. The aircraft wore Day Fighter Camouflage with black color on lower side of the wings and white stripes above and below the wings and whole nose section in white color, too. This ID was supposed for Dieppe operation but it can also be connected to Starkey operation or Rutter training. It served with No. 263 RAF Squadron from September 1940 to September 19, 1943 when it was lost in action.

Westland Whirlwind FB Mk.I, P6974, HE-M, No.263 Squadron RAF, letiště Angle, červen nebo srpen 1942. Stroj v denní stíhací kamufláži je atypický černou barvou na spodní ploše křídla s bílými pruhy a bílou příďí. V této podobě měl účastnit bojů nad Dieppe. Je však možné, že toto zbarvení souvisí s operací Starkey nebo cvičením Rutter. U No.263 Sq RAF létal od září 1940 až do 19. září 1943, kdy byl ztracen v akci. 28.3.1942 tento letoun přelétl S/O Cyril Nováček ze základny Colerne na letiště Dumfries. C. Nováček byl československý pilot, ve Francii dosáhl tří sestřelů. Vzhledem k tomu, že jej 10.6.1940 sestřelila a ranila vlastní (francouzská) protivzdušná obrana, přišel o část pravého chodidla a po evakuaci do Velké Británie nemohl bojově létat.

Camo B

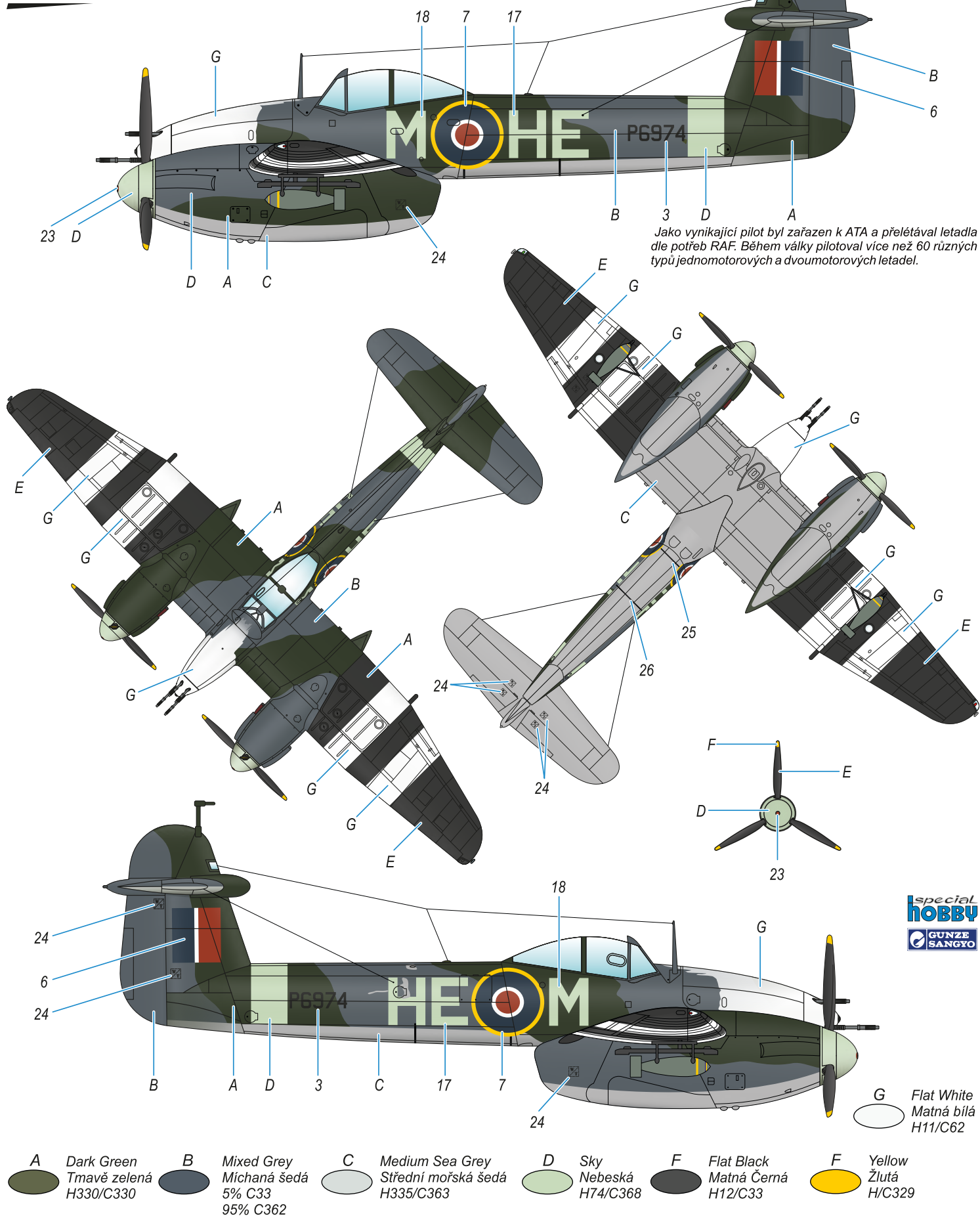

Westland Whirlwind FB Mk.I, P7102, SF-P, „Comrades In Arms“, P/O E.L. Musgrave, No.137 Squadron RAF. The upper surfaces' camouflage consisted of standard Dark Green and makeshift Mixed Grey. The inscription "Comrades in Arms" was written on the port board below the canopy. This machine served with No.137 Squadron RAF from June 1942 to September 1943, when it was handed over to No. 263 Squadron RAF. In September 1944 was this machine withdrawn from service and subsequently scrapped.

Westland Whirlwind FB Mk.I, P7102, SF-P, „Comrades In Arms“, P/O E. L. Musgrave, No.137 Squadron RAF. Na horních plochách nesl tento stroj mimo standardní Dark Green náhražkovou Mixed Grey. Jméno Comrades In Arms bylo napsáno na levém boku pod kabinou. U No.137 Squadron RAF sloužil tento stroj od června 1942 do září 1943. Pak byl předán No.263 Squadron RAF. Vyřazen a sešrotován byl v září 1944.

Camo C

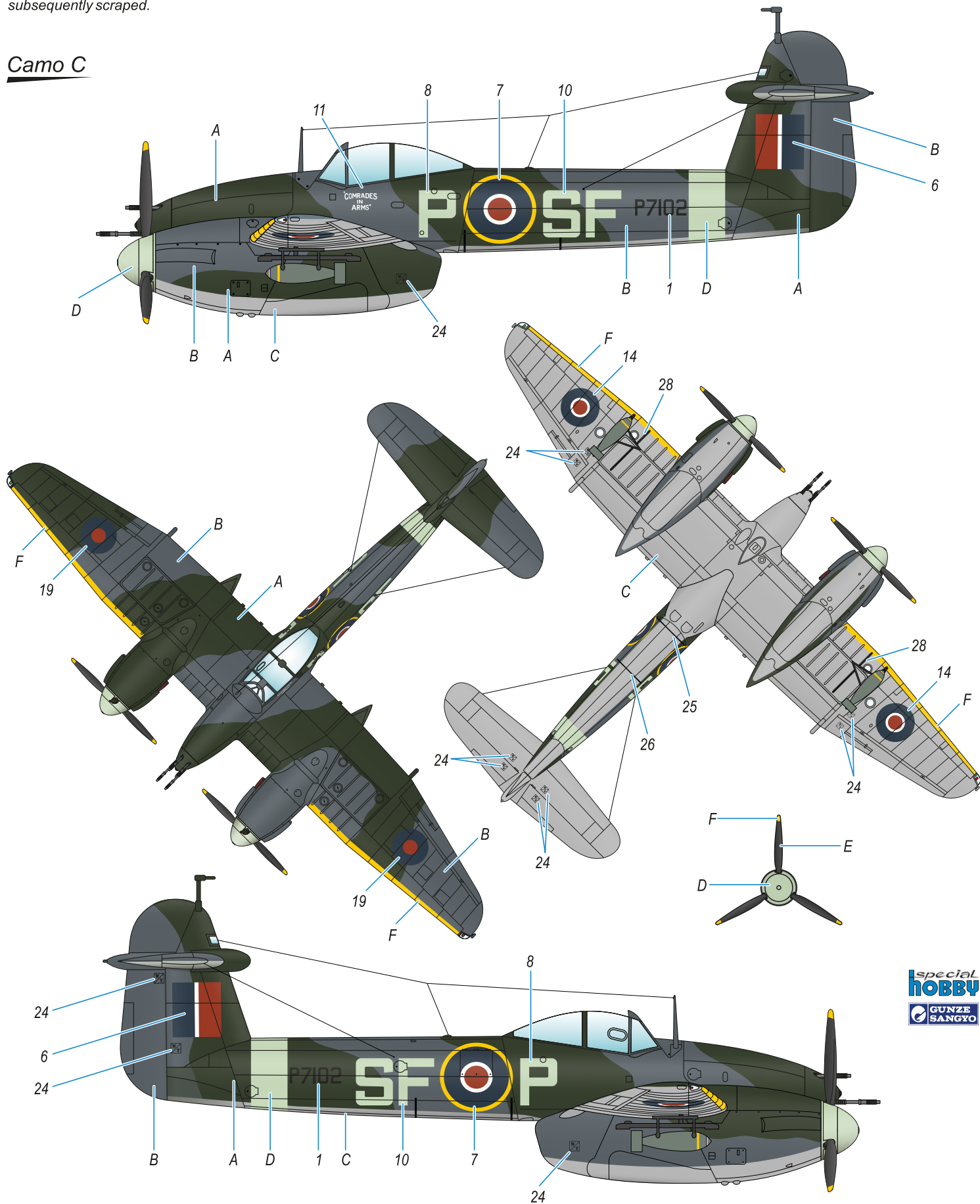

- | | | | | | |
|--|---|--|-------------------------------------|---|------------------------------------|
| A Dark Green
Tmavě zelená
H330/C330 | B Mixed Grey
Míchaná šedá
5% C33
95% C362 | C Medium Sea Grey
Střední mořská šedá
H335/C363 | D Sky
Nebeská
H74/C368 | F Flat Black
Matná Černá
H12/C33 | F Yellow
Žlutá
H/C329 |
|--|---|--|-------------------------------------|---|------------------------------------|

Westland Whirlwind FB Mk.I, P7012, SF-V, No.137 Squadron RAF. The upper surfaces' camouflage consisted of standard Dark Green and makeshift Mixed Grey. This machine served with No.137 Squadron RAF from November 1941 to June 1943, when it was handed over to No. 263 Squadron RAF. In July 1944 was this machine withdrawn from service and subsequently scrapped.

Westland Whirlwind FB Mk.I, P7012, SF-V, No.137 Squadron RAF. Na horních plochách nesl tento stroj mimo standardní Dark Green náhražkovou Mixed Grey. No.137 Squadron RAF používala tento stroj od listopadu 1941 do června 1943. Pak ho předala No.263 Squadron RAF. Vyřazen a zlikvidován byl v červenci 1944.

Camo D

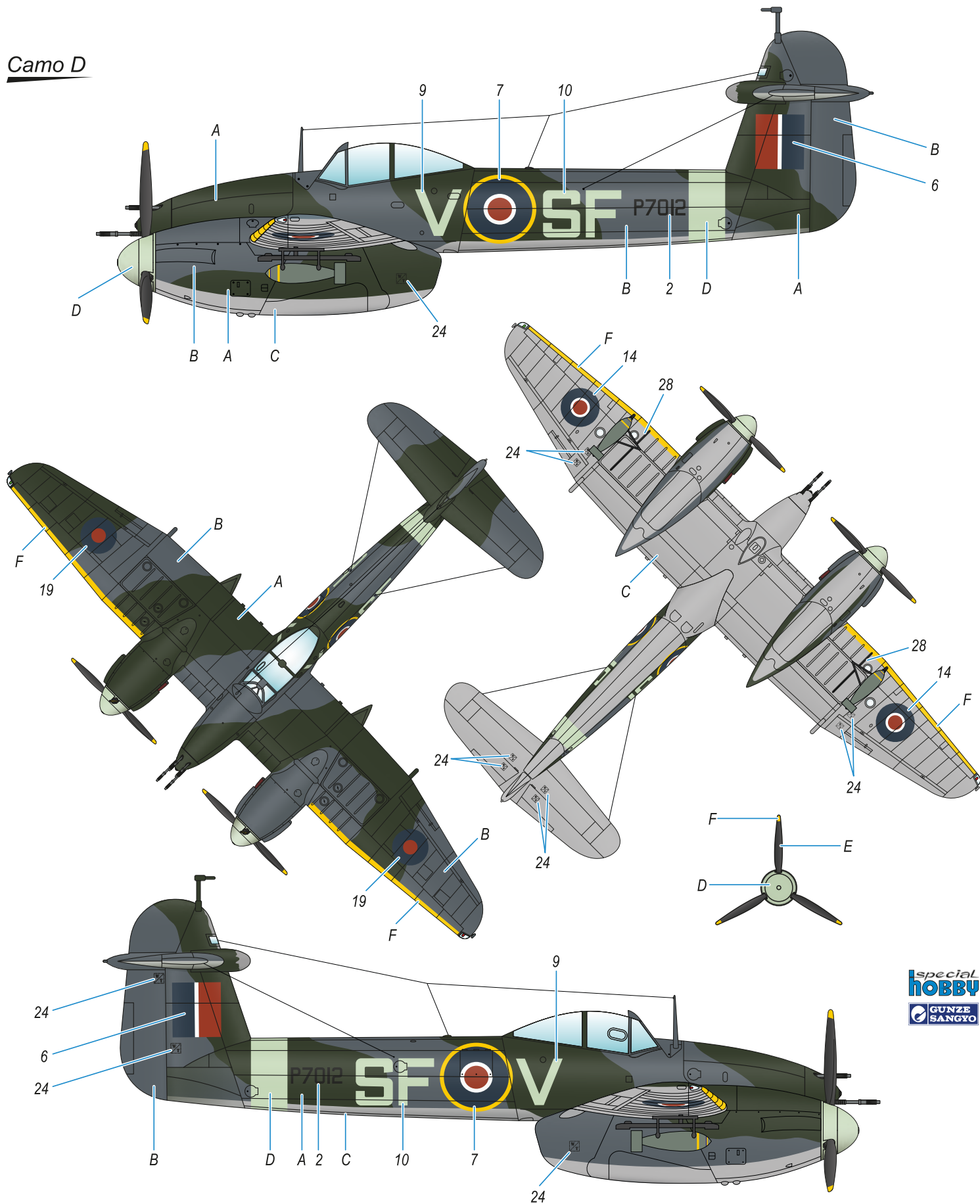

- | | | | | | |
|--|---|--|-------------------------------------|---|------------------------------------|
| A Dark Green
Tmavě zelená
H330/C330 | B Mixed Grey
Míchaná šedá
5% C33
95% C362 | C Medium Sea Grey
Střední mořská šedá
H335/C363 | D Sky
Nebeská
H74/C368 | F Flat Black
Matná Černá
H12/C33 | F Yellow
Žlutá
H/C329 |
|--|---|--|-------------------------------------|---|------------------------------------|