

## SAAB AJ 37 Viggen 'Strike Fighter'

### Historie

CZ

SAAB 37 Viggen je letoun, který předběhl svou dobu. Neortodoxní řešení, zvolená jeho konstruktéry, nejen umožnily Viggenu splnit požadavky na něj kladené, ale v některých parametrech je předčit. Švédské letectvo objednalo Viggen v několika verzích, s tím, že základní provedení letounu tvořilo univerzální platformu, která doplněná o speciální vybavení, umožňovala použití v několika rolích.

První ze sedmi stavěných prototypů vzletl 8. února 1967, řízen pilotem E. Dalsrömem. Pohon zajišťoval motor Volvo RM8, licenční civilní motor Pratt & Whitney JT8D doplněný o přídavné spalování a obraceče tahu. To, stejně jako koncepce dvojitých delta křídel přispívalo k vynikajícím vlastnostem Viggenu při startech a přistáních na malých přistávacích plochách. Pro lepší manipulaci s letouny po přistání umístění do hangárů či jejich lepšímu zamaskování při operacích z nestandardních ploch dostal Viggen sklopnou svislou ocasní plochu. Elektronické vybavení bylo ve své době jedno z nejlepších na světě. Viggen byl první stroj se zabudovaným počítačem s integrovanými obvody. Do výzbroje švédského letectva byla jako první zařazena verze AJ 37 Viggen, kterou postupně následovaly verze SK 37 - dvoumístný cvičný stíhací letoun, SF 37 - průzkumná verze s fotografickými přístroji v upravené přídi, SH 37 - protilodní verze s odlišným elektronickým vybavením a protilodní výzbrojí. Po cca deseti letech od zařazení první verze byla vyrobena druhá generace Viggenu, stíhací verze JA 37. Ta dostala modernizované elektronické vybavení a silnější motor v nepatrně prodlouženém trupu. Modernější elektronické vybavení dostaly i starší verze, přestavbou vznikaly stroje AJS 37, případně ASFS a ASHS 37. Část dvoumístných cvičných strojů byla přestavěna na verzi pro výcvik elektronického boje SK 37E. Švédské letectvo vyřadilo poslední Viggenu v roce 2007. Export Viggenu se nezdařil, většinou z politických důvodů. Mezi největší zájemce patřila např. Indie, ale zájem projevovaly i skandinávské země či Japonsko.

délka: 16,30 m, rozpětí: 10,60 m, max. rychlost: 2145 km/h, dolet standardní: 1000 km/maximální: 2000 km, dostup: 18 300 m, rychlost stoupání: 100 m/s

### History

GB

The SAAB AJ 37 Viggen was an aircraft ahead of its time. Its designers used an unorthodox construction which enabled the plane to meet all requirements which had been laid on it and in some parameters even surpass them. The Swedish Air Force ordered several various versions of the Viggen jet fighter, its basic design formed an universal platform which, using a specialized equipment, enabled the plane to be used for different roles.

The first of seven prototypes took off for its maiden flight on February 8, 1967 with E. Dalsröm at the controls. The aircraft was powered by Volvo RM8 turbofan, a licence-built variant of Pratt & Whitney JT8D with an afterburner and thrust-reverser which, in addition to a double-delta wing design, enhanced the aircraft's performance during the take-offs and landings on short airstrips. The tailfin was designed as foldable to make it easier to store in hangars, it also helped with handling the aircraft after the landing and with hiding at the emergency airstrips. The avionics of the type was one of the best in the world in the time, Viggen was the first type to be equipped with a computer with integrated circuits.

The first version of the Viggen which saw service with the Flygvapnet was the AJ 37 strike fighter, followed consequently by the SK 37 two-seat trainer, SF 37 reconnaissance version with cameras in redesigned nose section and anti-shiping SH 37 with different avionics and equipped with anti-shiping weapons. Ten years after the first version of the SAAB had entered service, a second generation of the Viggen came into being, which was the JA 37 fighter version. More modern avionics was used and also a more powerful engine in a slightly longer fuselage. The earlier versions became to be equipped with the modernised avionics too and this way the AJS 37, respectively ASFS and ASHS 37 versions were created. Some of the two seat airframes were converted to the SK 37 E electronic warfare trainers.

The last of the Viggens were phased out in 2007. Mainly for political reasons, no Viggen has ever been exported to another countries, although India, Japan and Scandinavian countries showed some interest in the type.

Lenght: 16.30 m, Wingspan: 10.60 m, Max. speed: 2,145 km/h, Standard Range: 1,000 km/ Max. Range: 2,000 km, Ceiling: 18,300 m, Rate of Climb: 100 m/s

# Plastic Parts

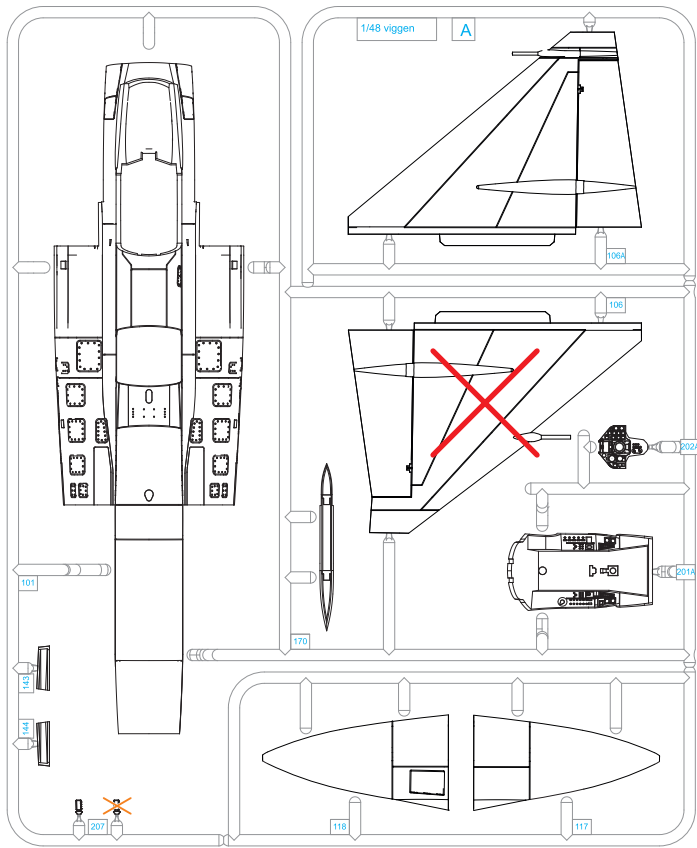

**A**

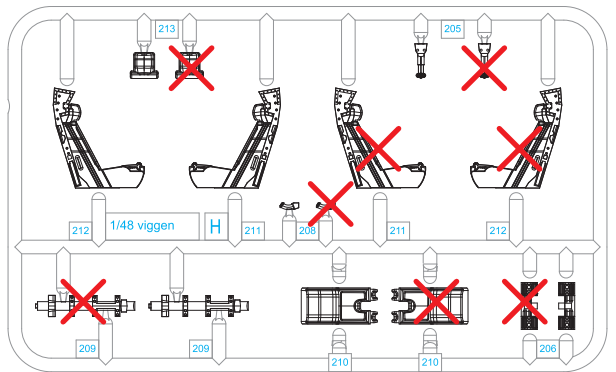

**H**

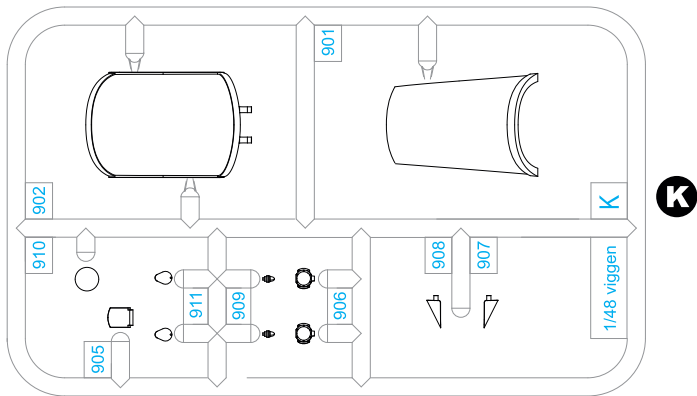

**G**

**K**

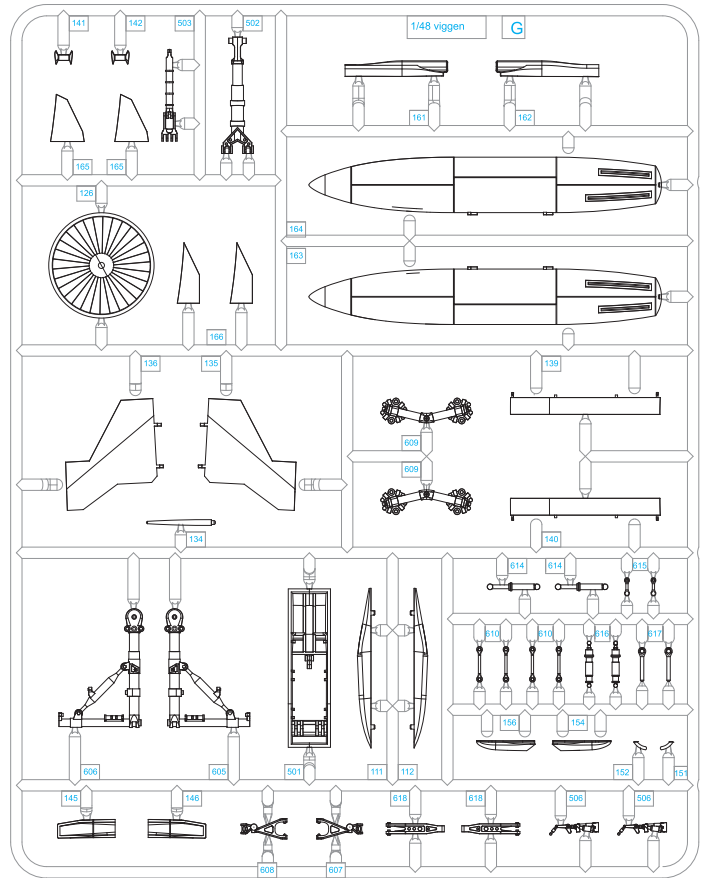

## Photo-Etched Parts PE1-PE32

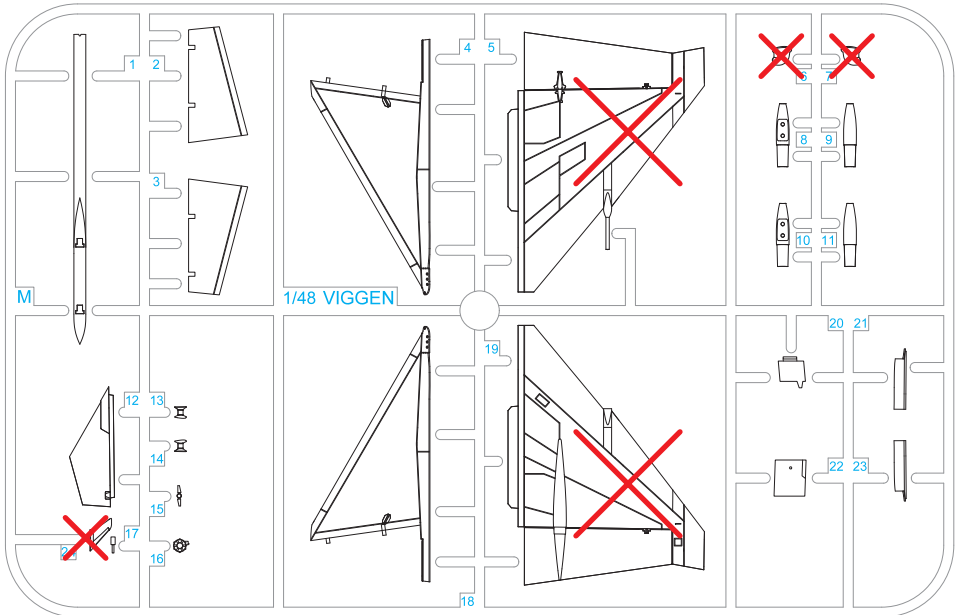
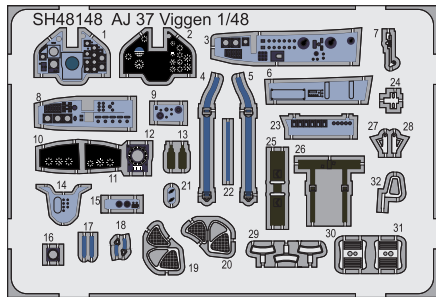

**M**

**X** - Tento díl nepoužít  
Do not use this part

### SYMBOLS

**?** MOŽNOST VOLBY  
OPTIONAL  
NACH BELIEBEN  
OPTION

**🔹** POUŽÍT KYANOAKRYLÁTOVÉ LEPIDLO  
INSTANT CYANOACRYLATE GLUE  
ZYANOAKRYLÁTKLEBER  
ADHÉSIF CYANOACRYLAT

**↩** OHNOUT  
BEND  
BIEGEN  
COURBER

**👉** ZHOTOVIT NOVÉ  
SCRATCH BUILD  
FERTIGSTELLEN  
ACHEVER

**✂** ŘEZAT/VRTAT  
CUT OFF/DRILL  
ENTFERNEN  
DETACHER

**A** GSI  
colours code  
NATRÍT  
COLOUR  
FARBEN  
PEINDRE

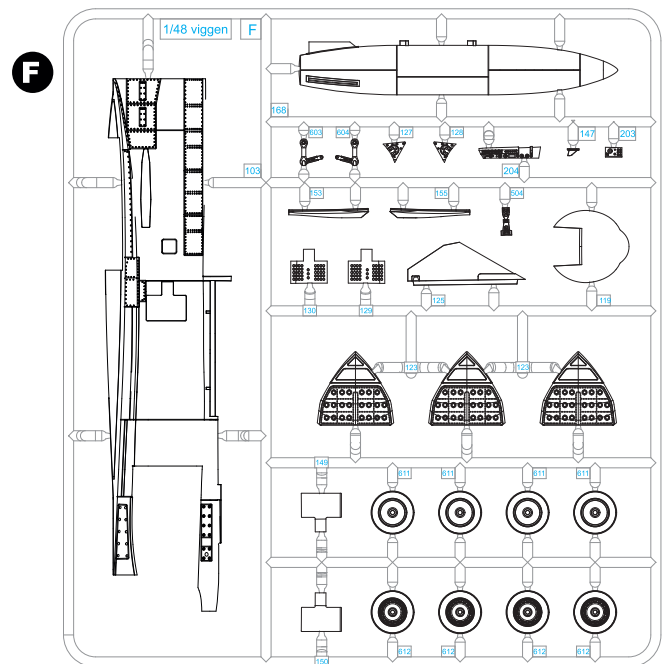
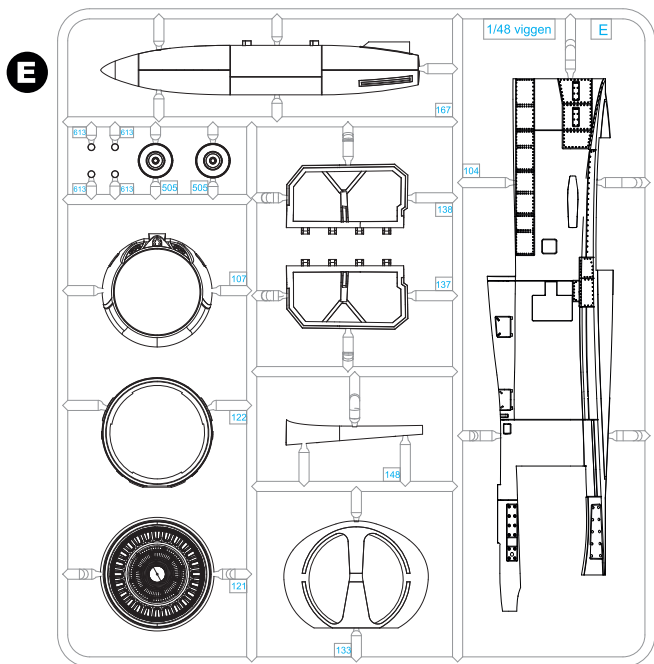
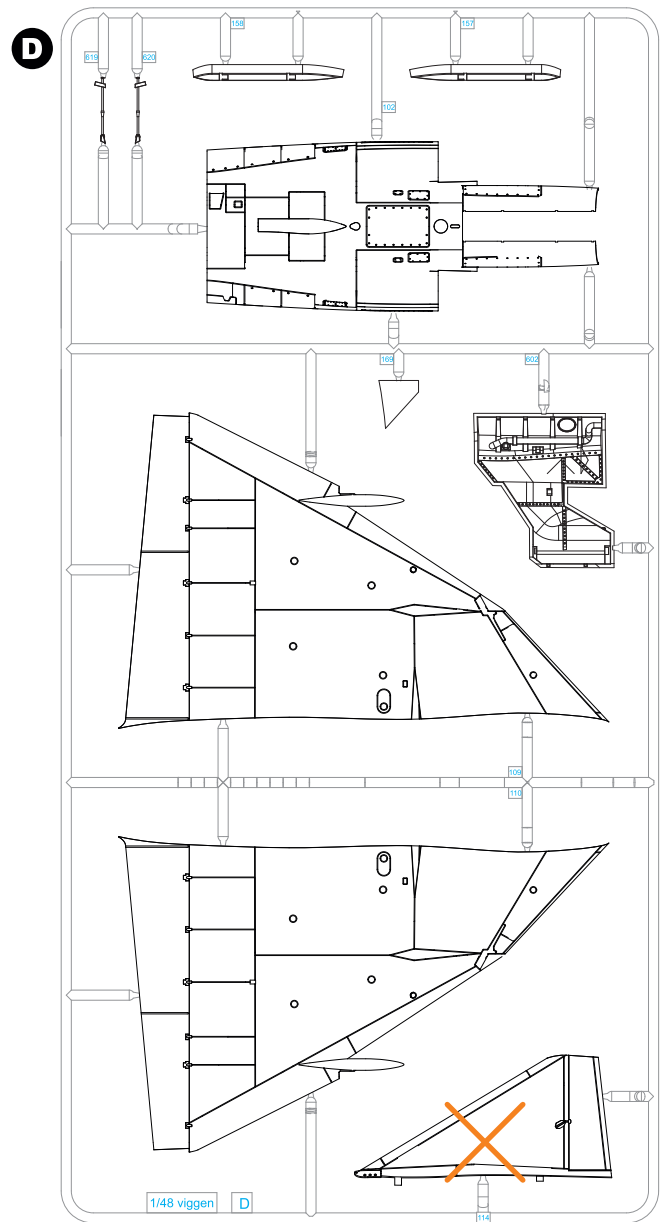
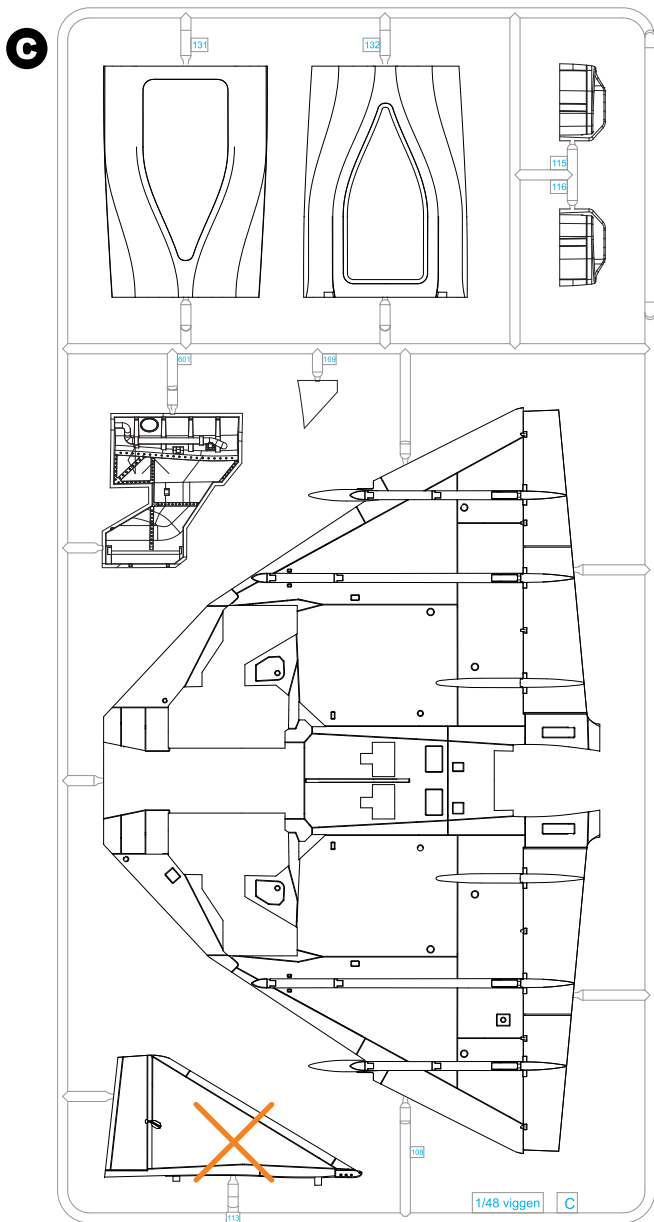

<b>A</b> Červená/ RED	H3/C3	<b>F</b> Opálený kov/ BURNT IRON	H76/C61	<b>K</b> Tm. zelená/ DARK GREEN	H309/ C309	<b>P</b> Titan/ TITANIUM	SM05
<b>B</b> Žlutá/ YELLOW	H4/C4	<b>G</b> Černá pneum./ TIRE BLACK	H77/C137	<b>L</b> Hliník/ ALUMINIUM	MC218	<b>Q</b> Červenohnědá/ RED BROWN	H47/ C41
<b>C</b> Černá/ BLACK	H12/C33	<b>H</b> Šedá/ GREY	H308	<b>M</b> Sv. zelená/ LIGHT GREEN	H58/ C27	<b>R</b> Čirá modrá/ CLEAR BLUE	H93/ C50
<b>D</b> Ocel/ STEEL	H18/C28	<b>I</b> Sv. zelená/ LIGHT GREEN	H319	<b>N</b> Sv. hnědá/ TAN	H310/ C310	<b>S</b> Čirá červená/ CLEAR RED	H90/ C47
<b>E</b> Zelená/ BRIGHT GREEN	H26/C66	<b>J</b> Sv. šedá/ LIGHT GREY	H338	<b>O</b> Hliník/ ALUMINIUM	SM01	<b>Barvy GUNZE/ GUNZE Colour No.</b>	

# ASSEMBLY

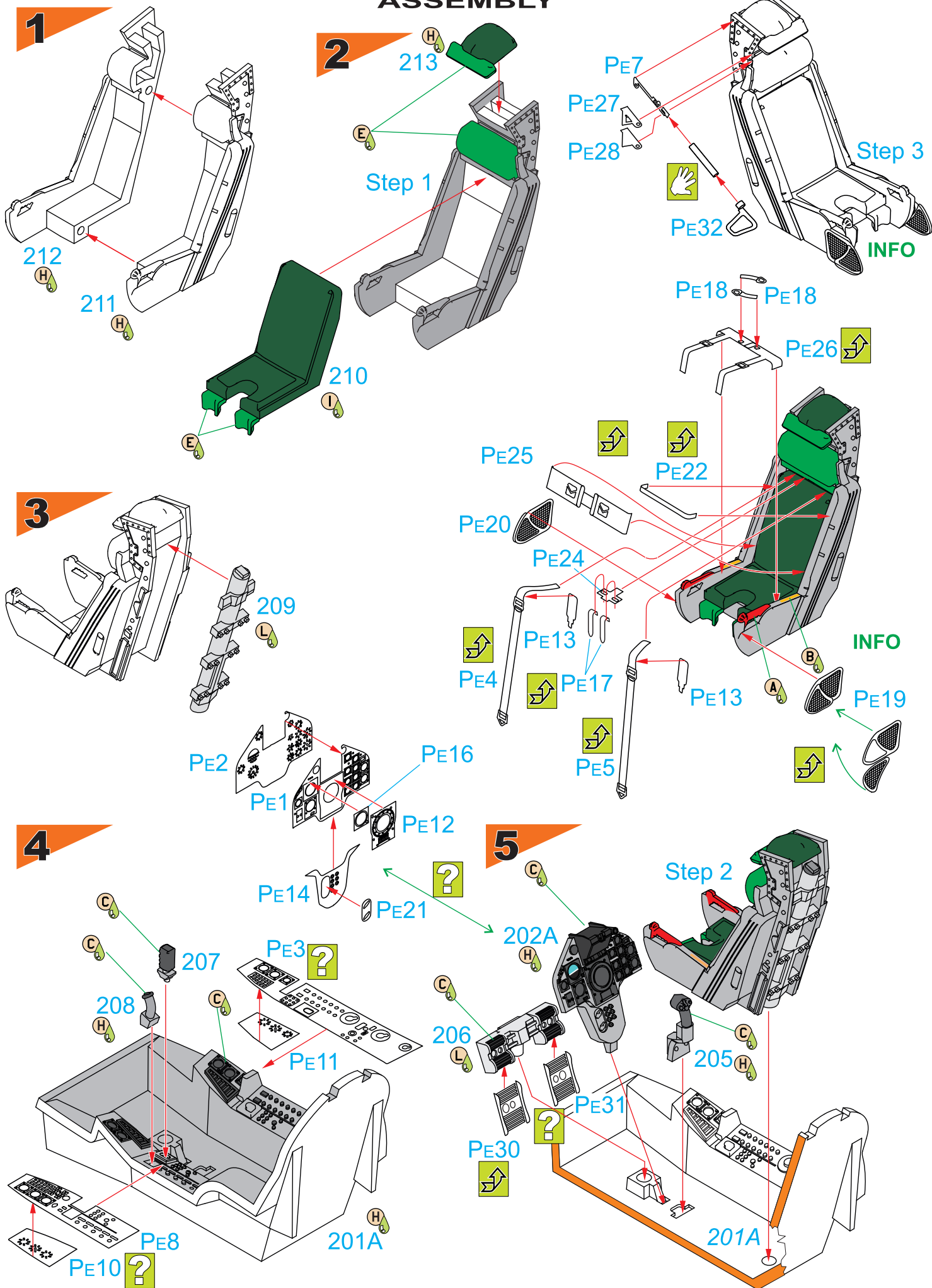

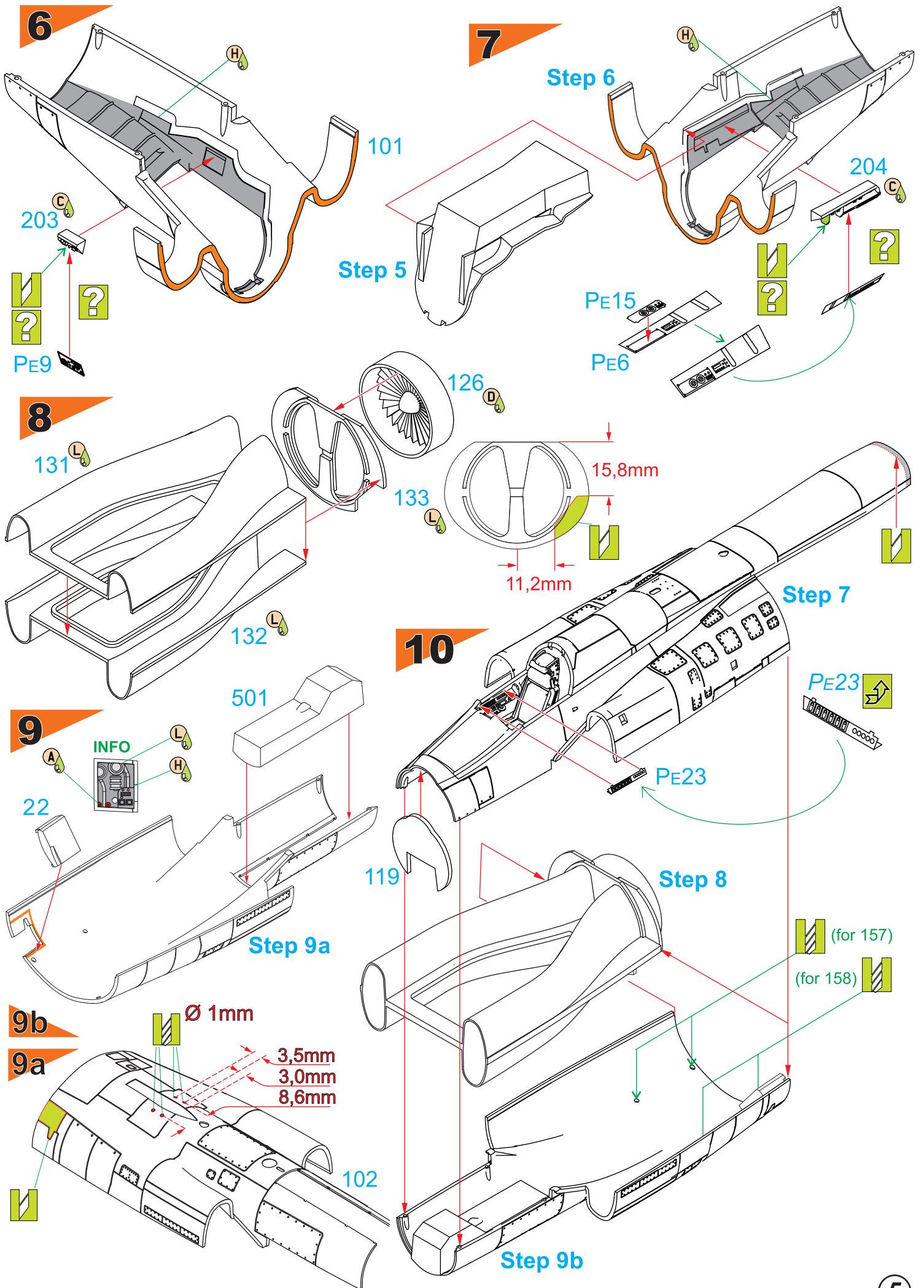

# 11

INFO  
121-orientation

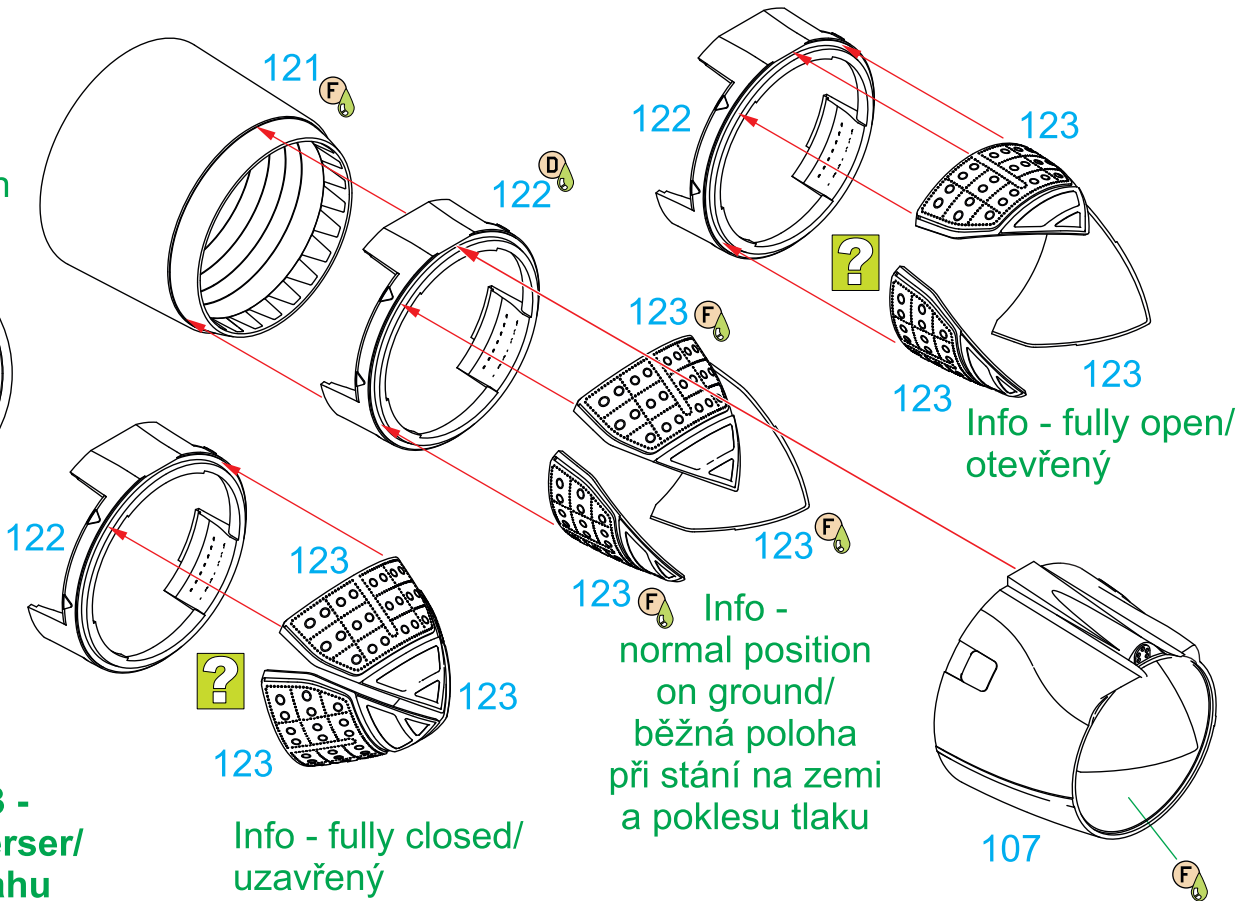
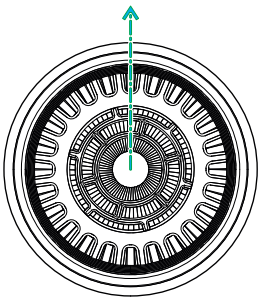

# 12

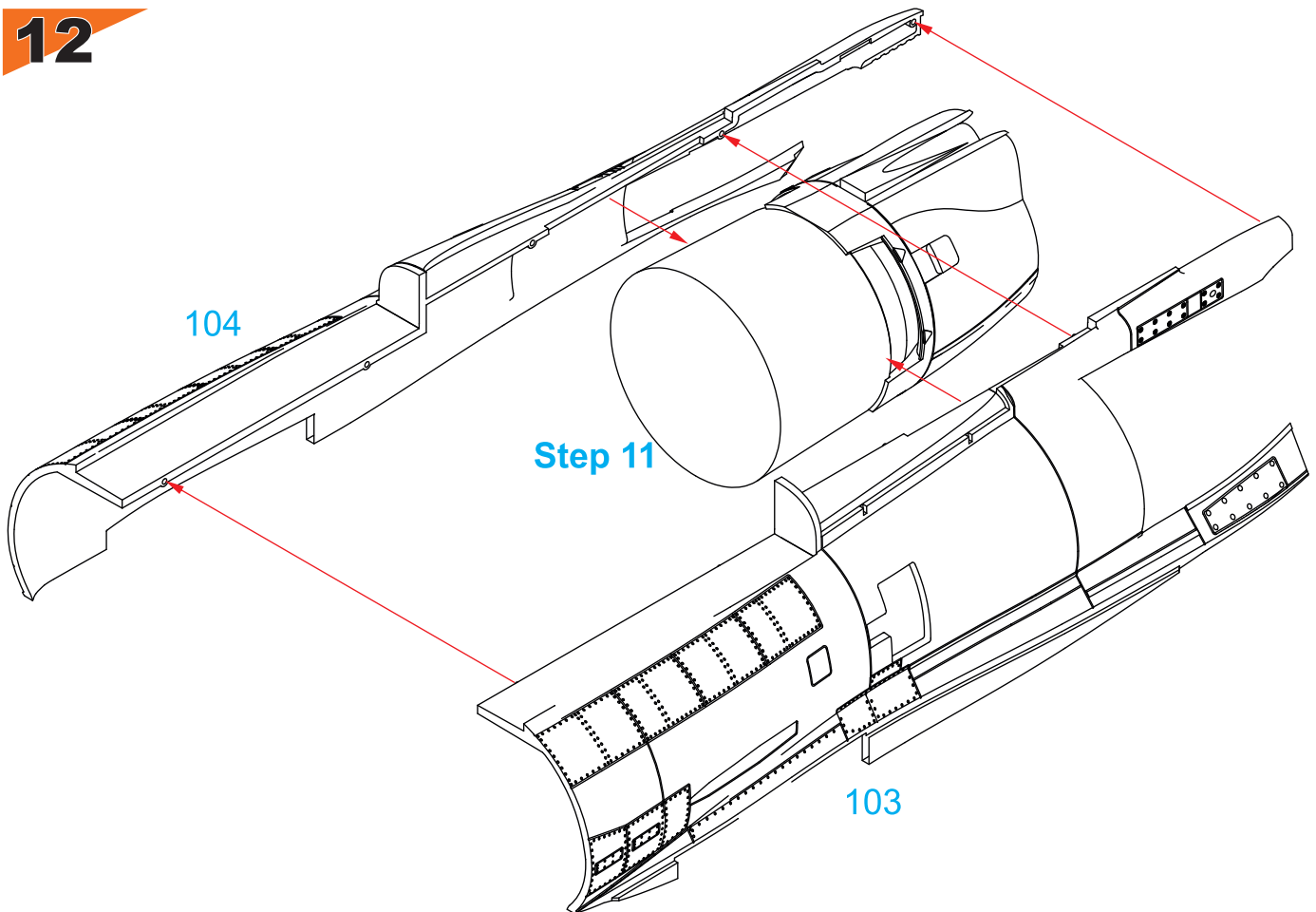

**13**

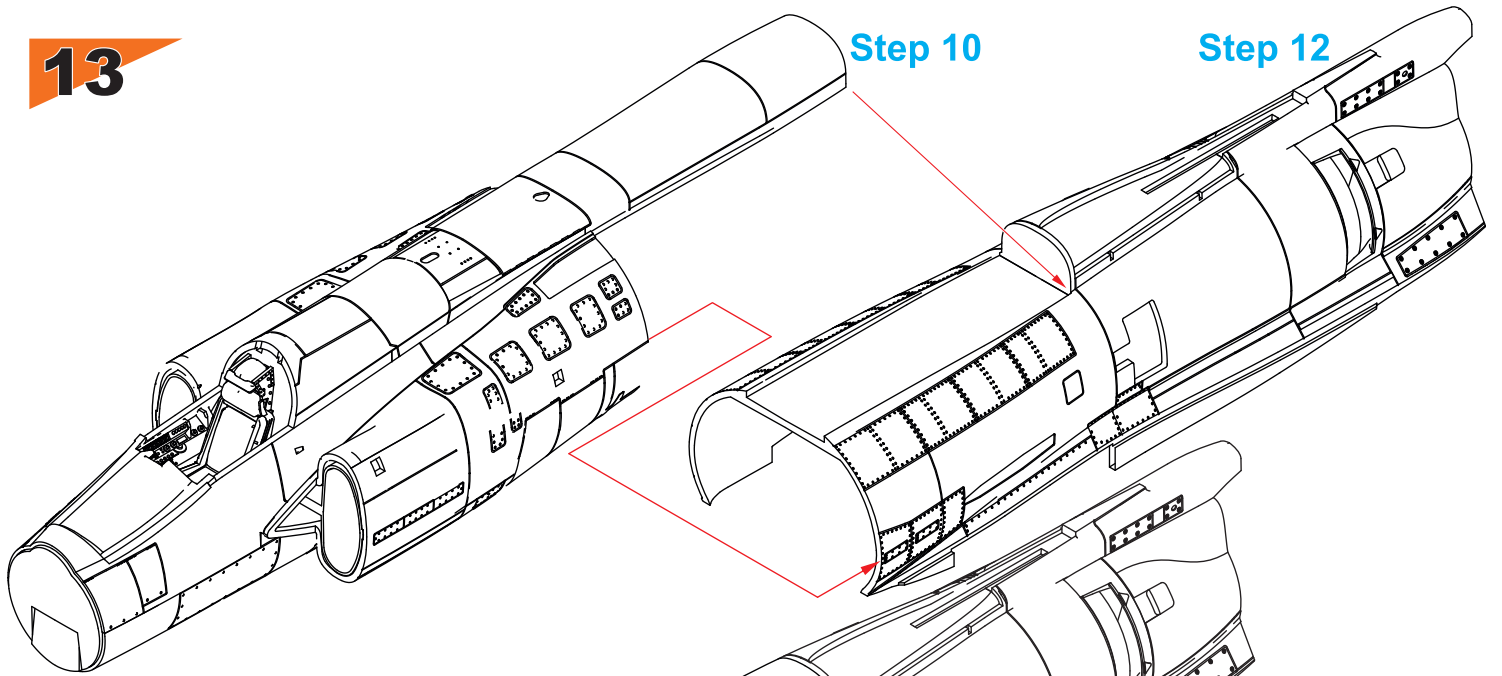

**14**

Step 13

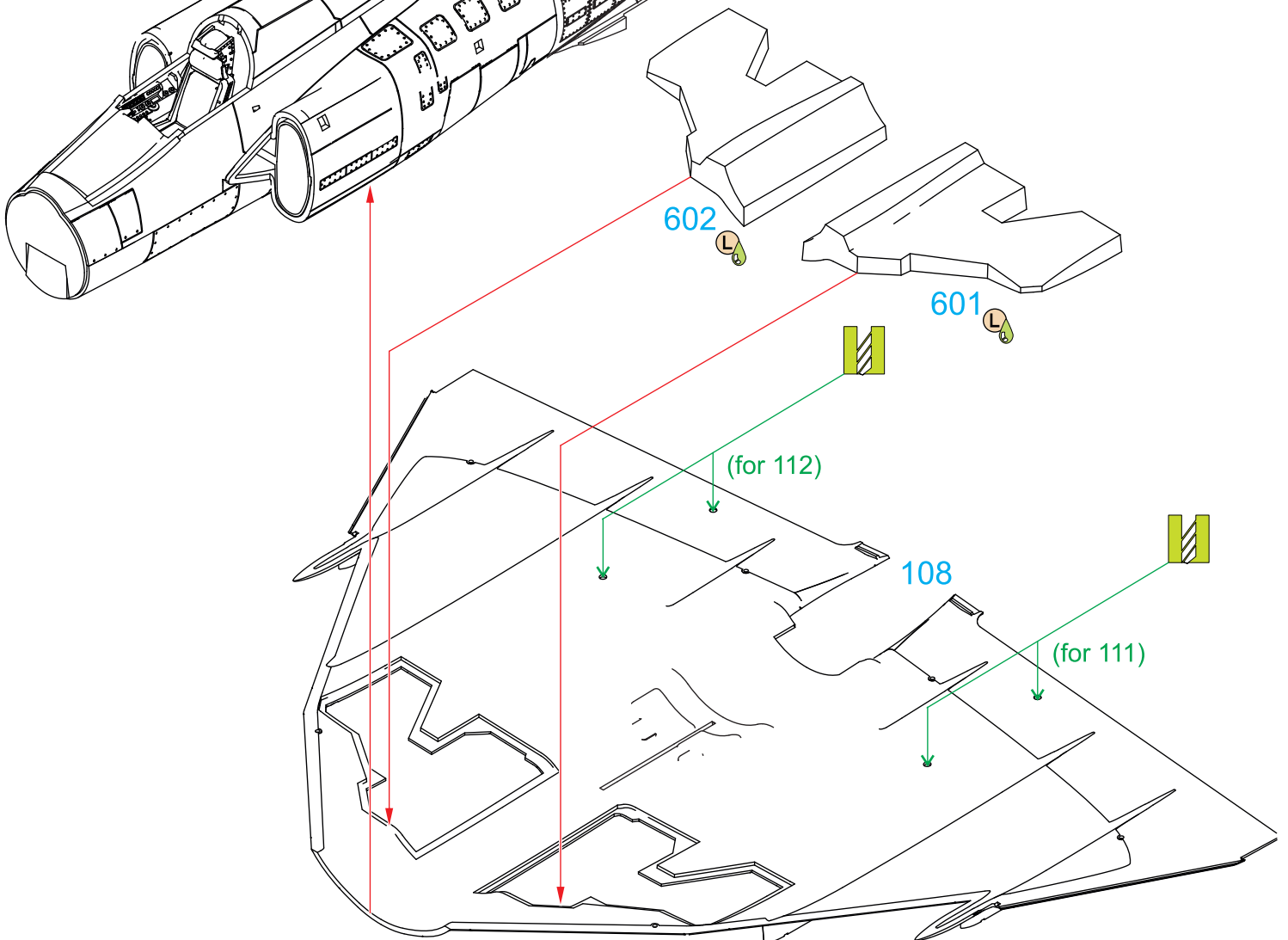

**15**

The model is balanced to correctly stand on its main landing gear. However, if you plan to add aftermarket equipment, it is a good idea to add some ballast in the nose to avoid model becoming a tailsitter.

Model by měl stát bez dovážení na svém podvozku, nicméně chcete-li na něj přidat dodatečnou výzbroj, bude dobré přidat zátěž do špičky trupu, aby model nebyl „těžký na ocas“ a nepadal na zadní část..

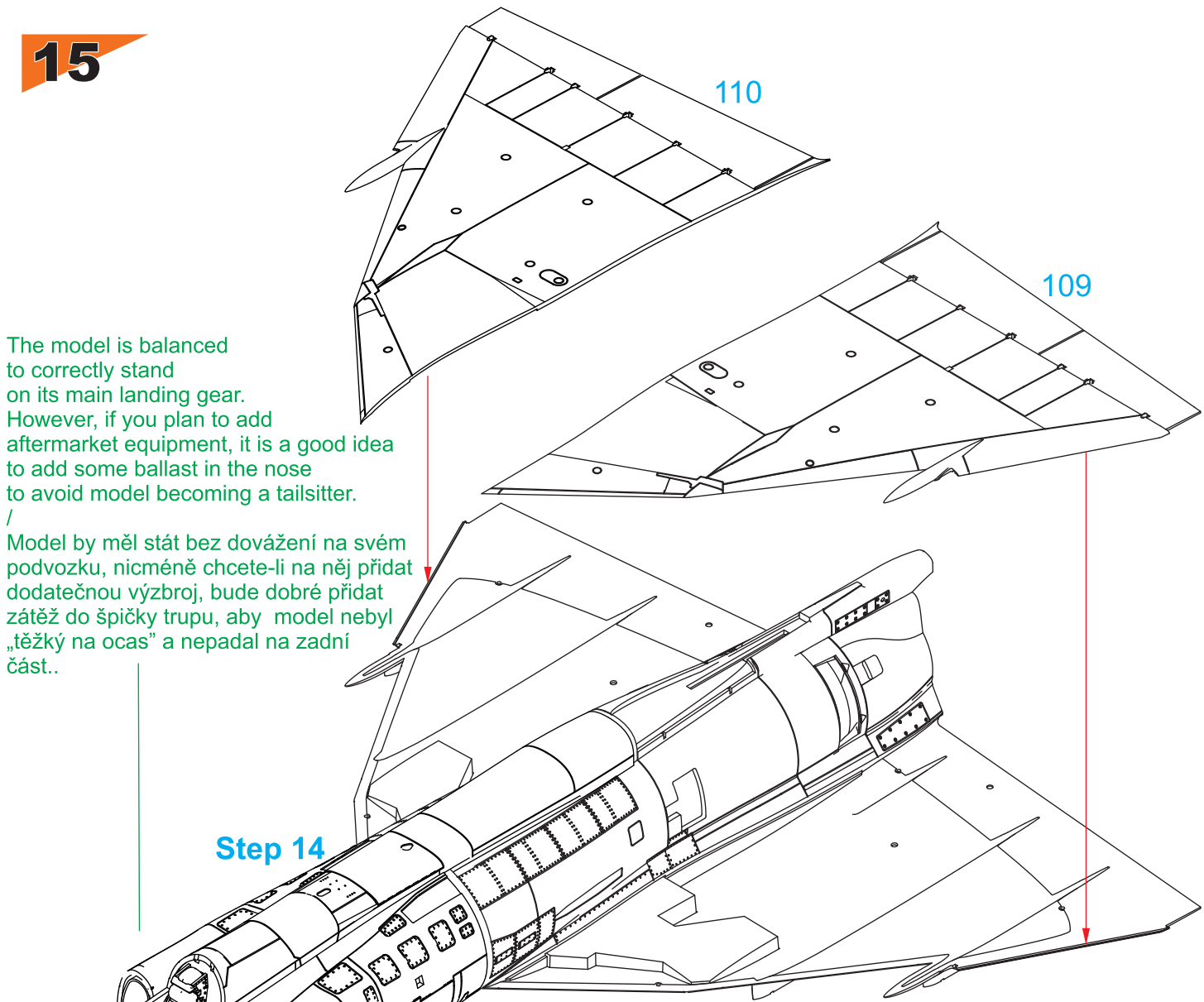

**Step 14**

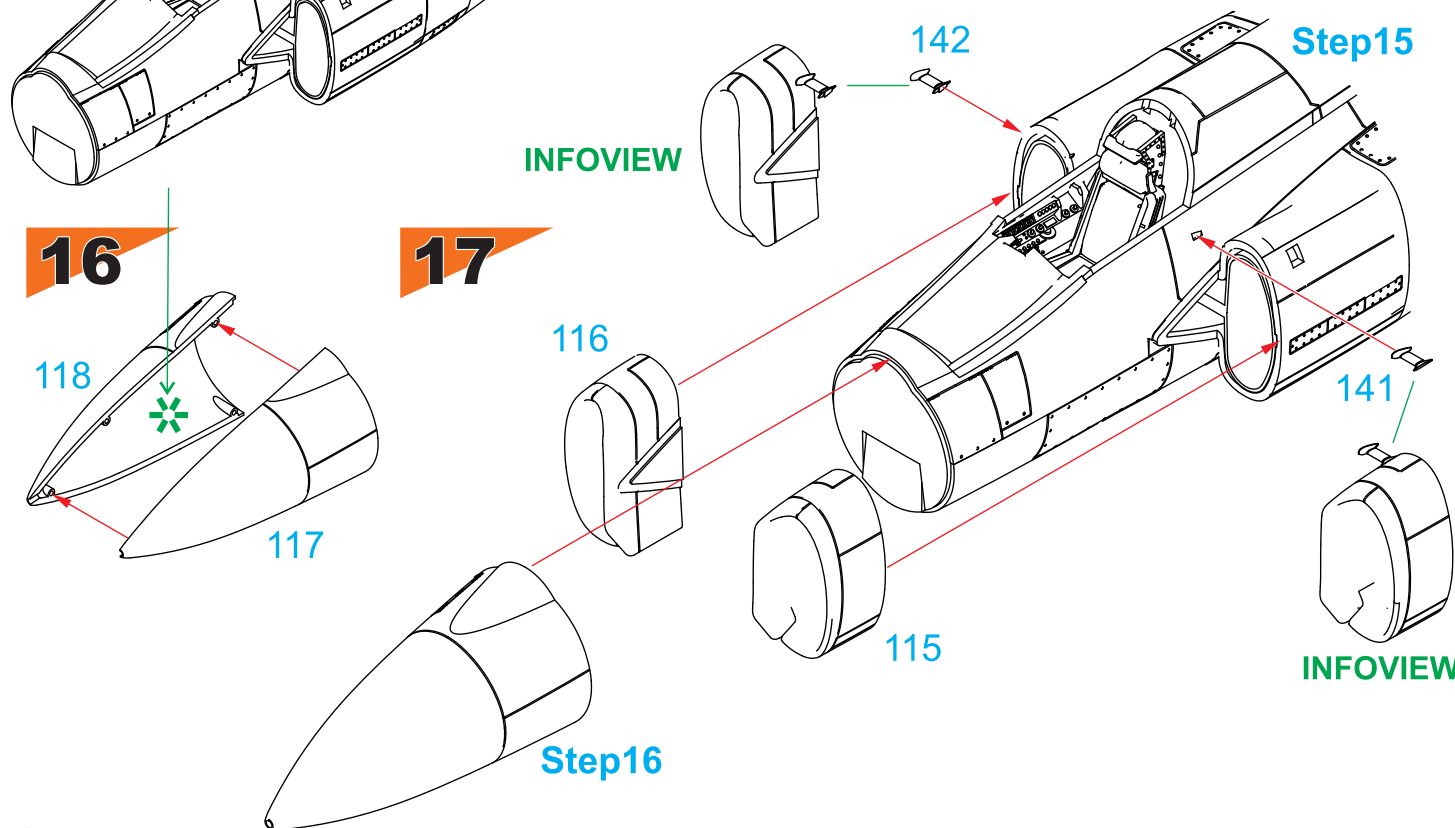

**Step 15**

INFOVIEW

INFOVIEW

**16**

**17**

118

117

116

115

141

**Step 16**

**8**



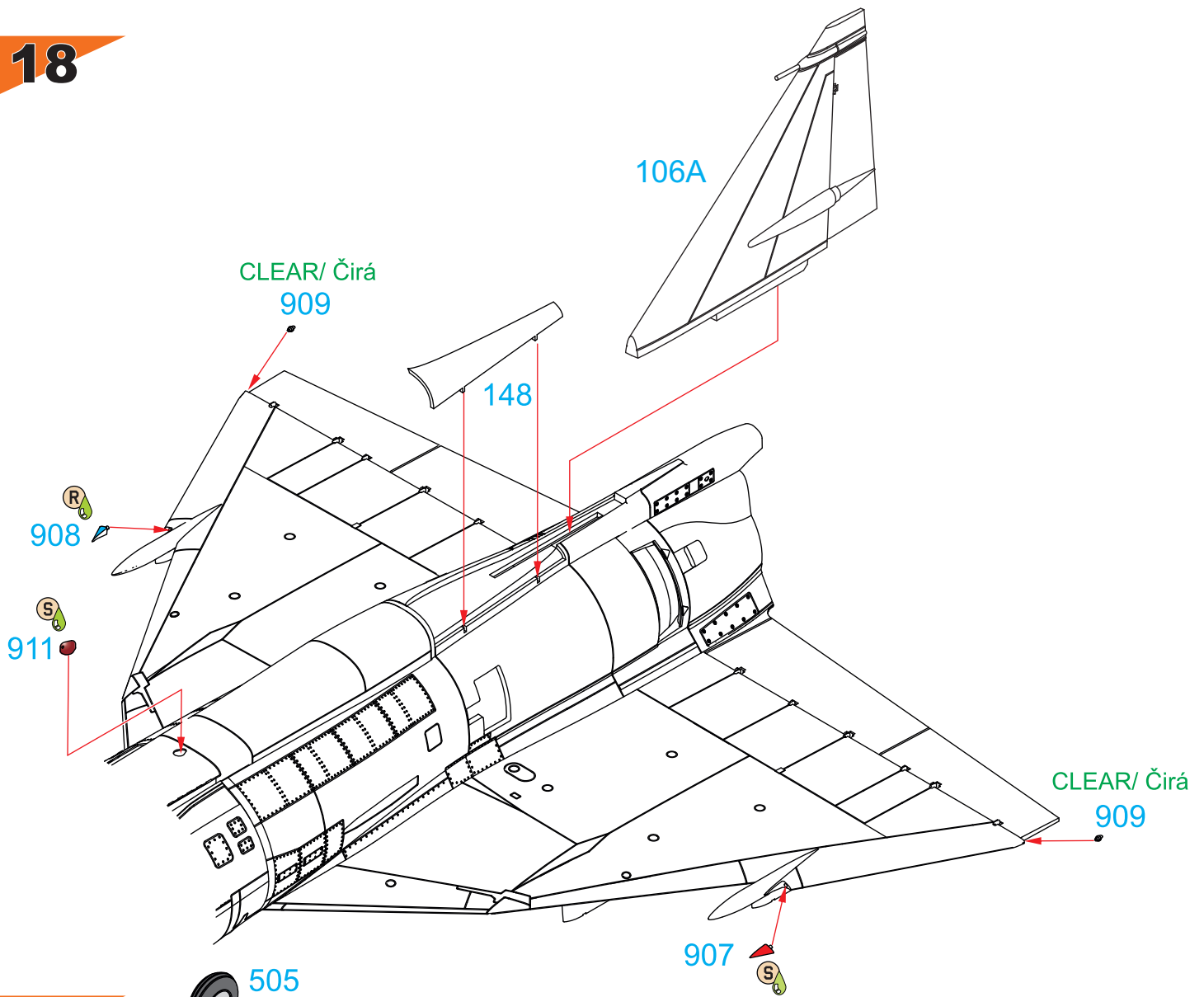

19a

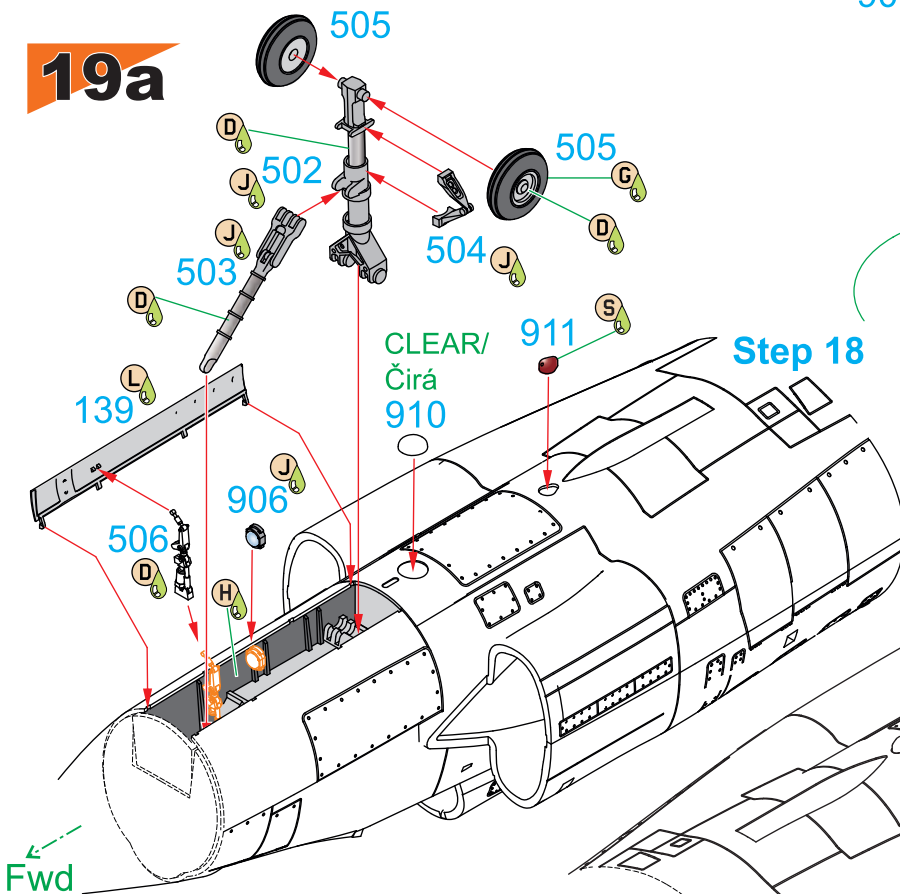

Step 18

19b

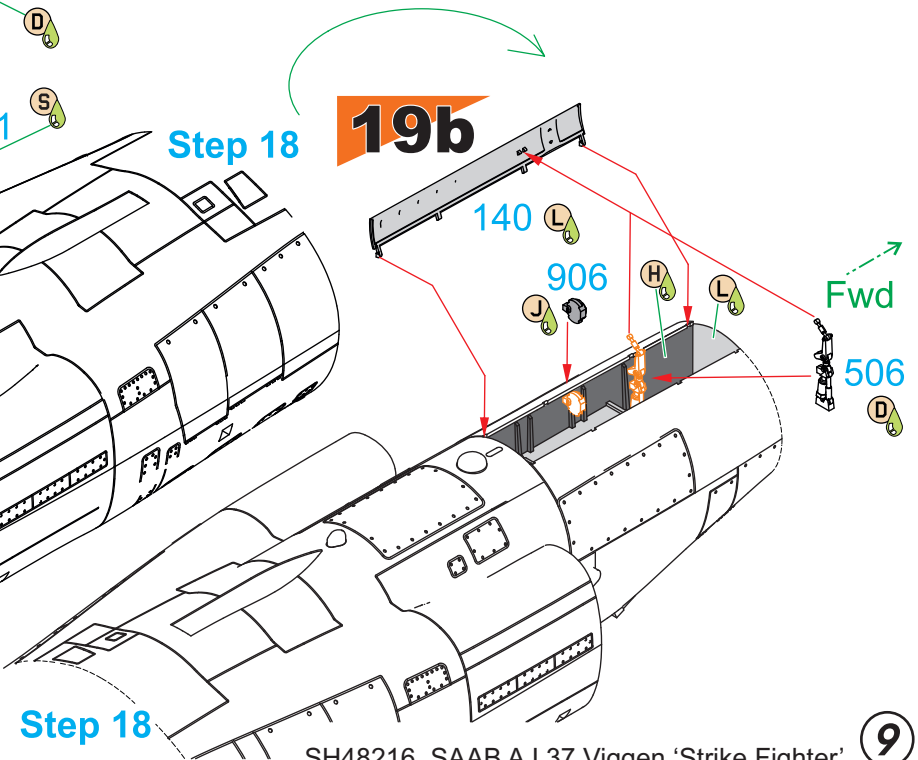

Step 18

# 20L

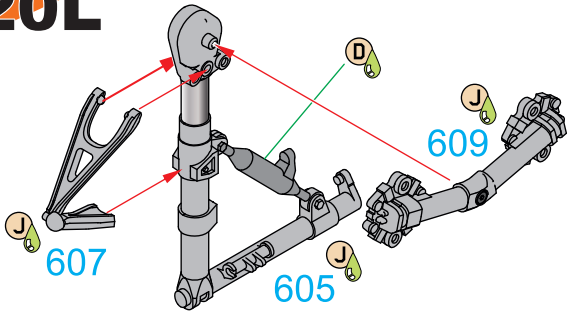

# 21L

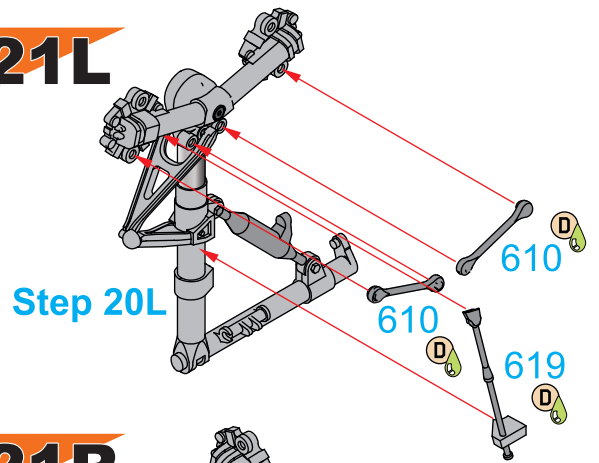

# 20R

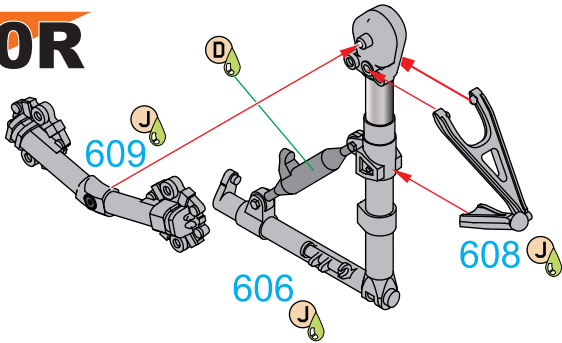

# 21R

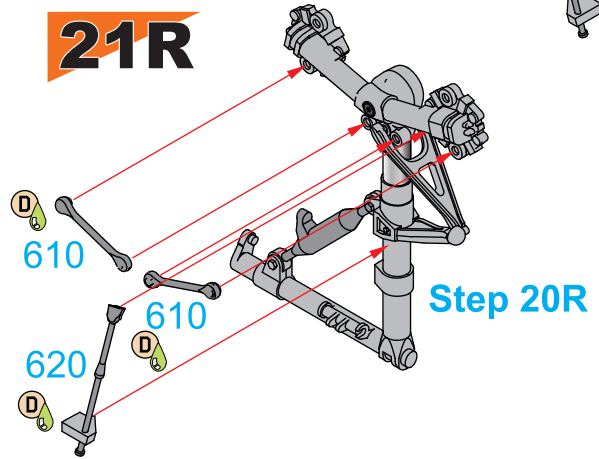

# 22L

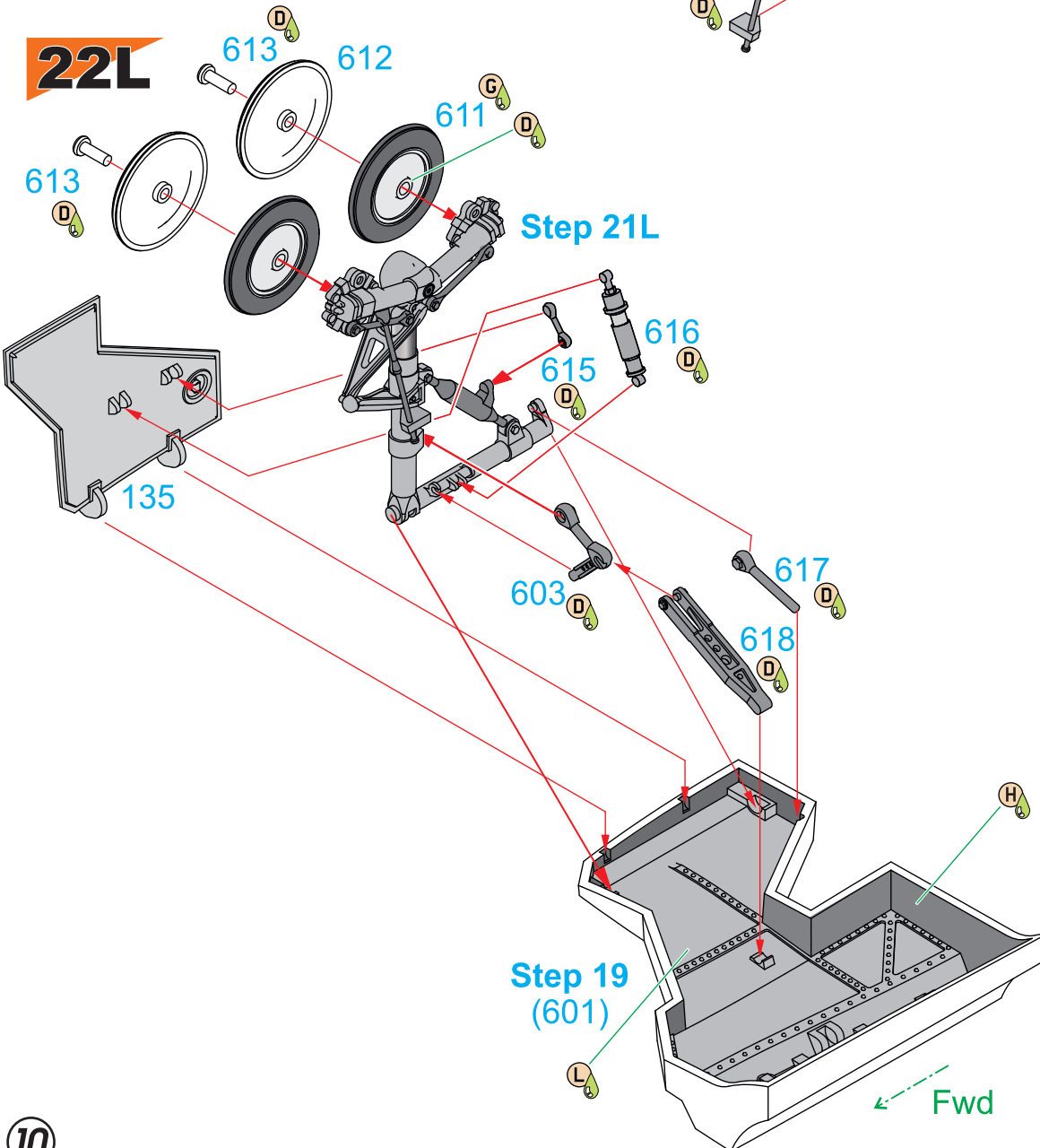

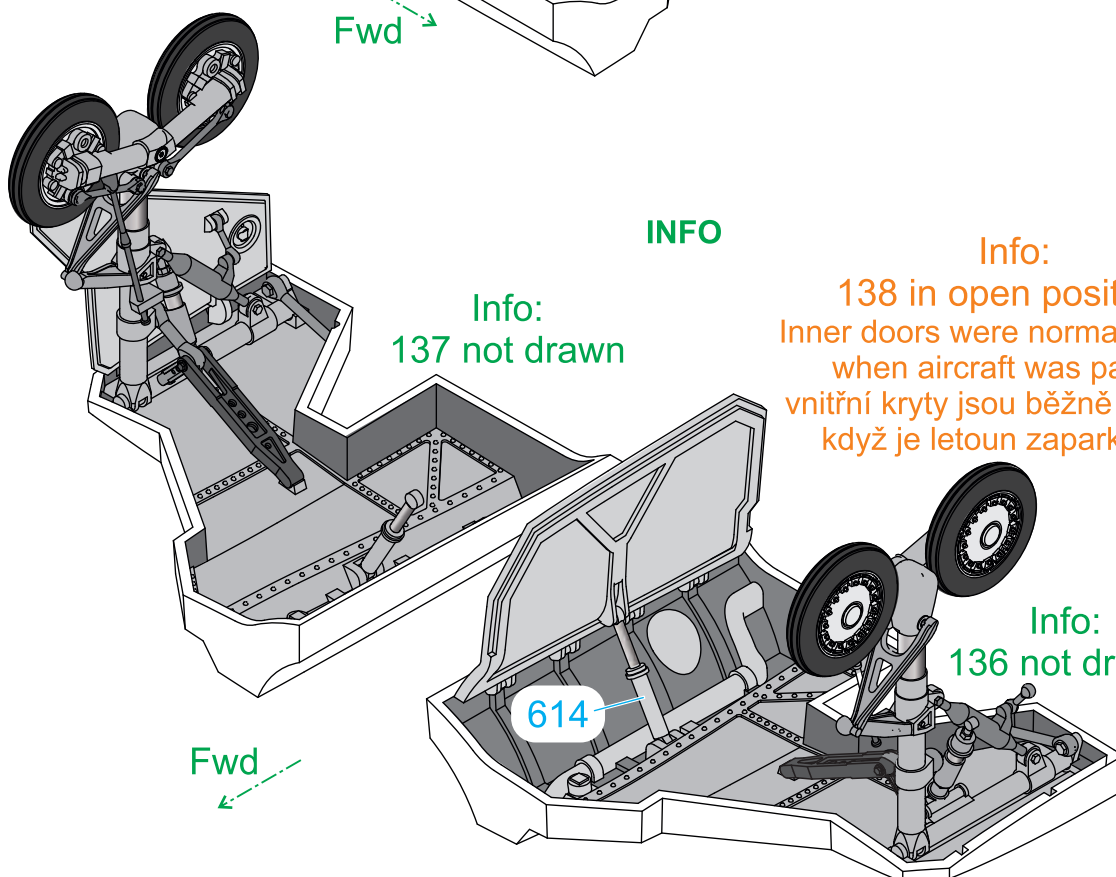
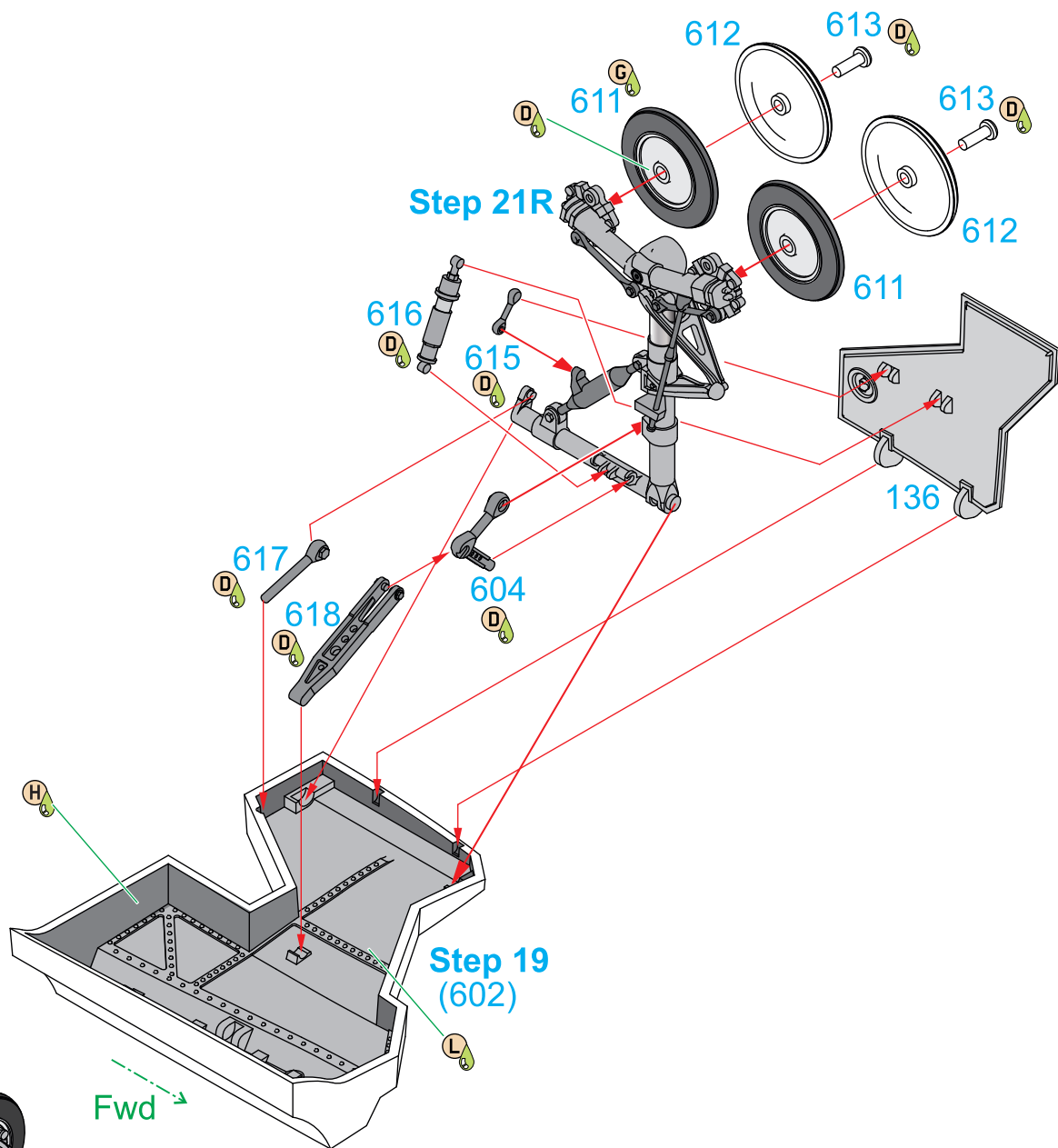

**23**

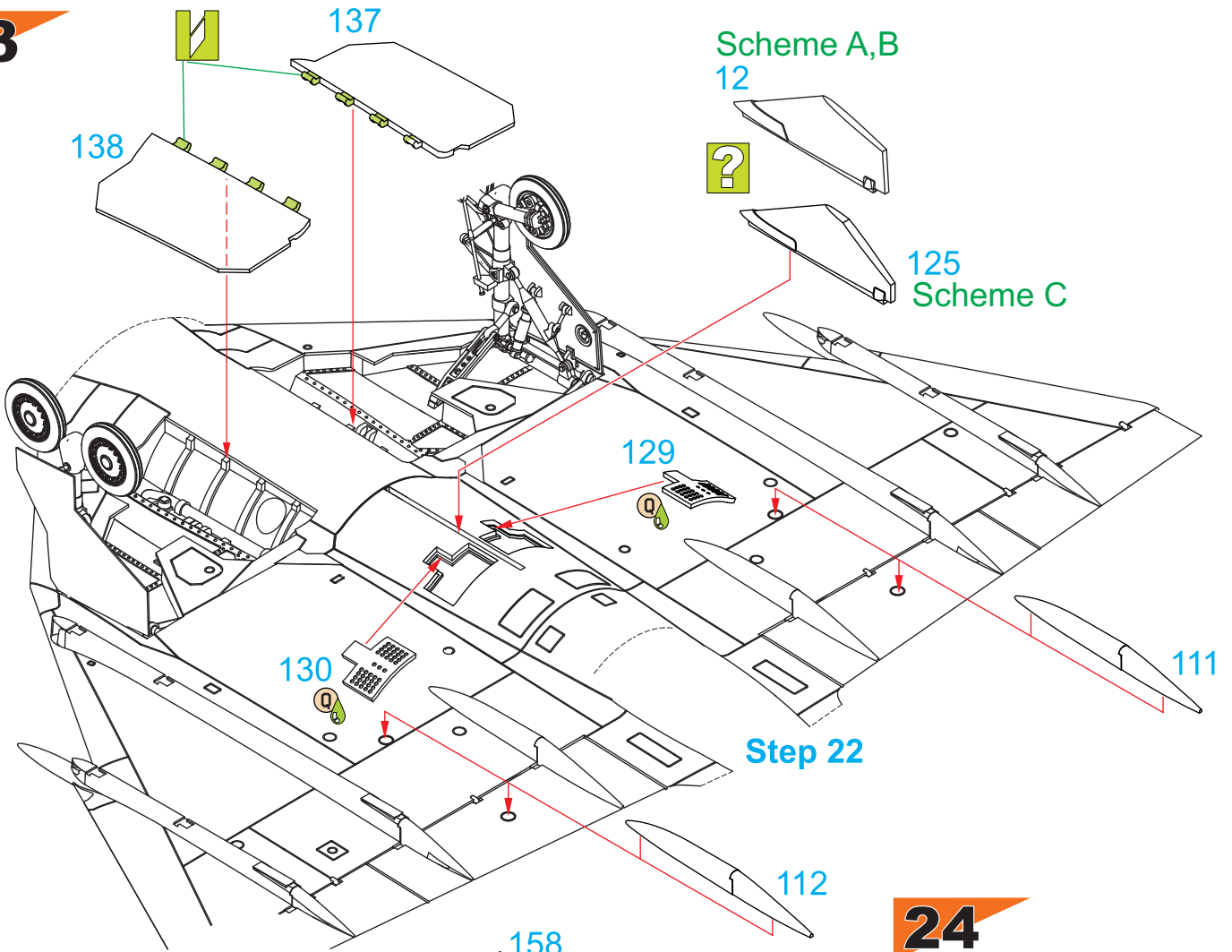

**24**

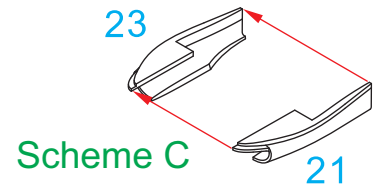

**25**

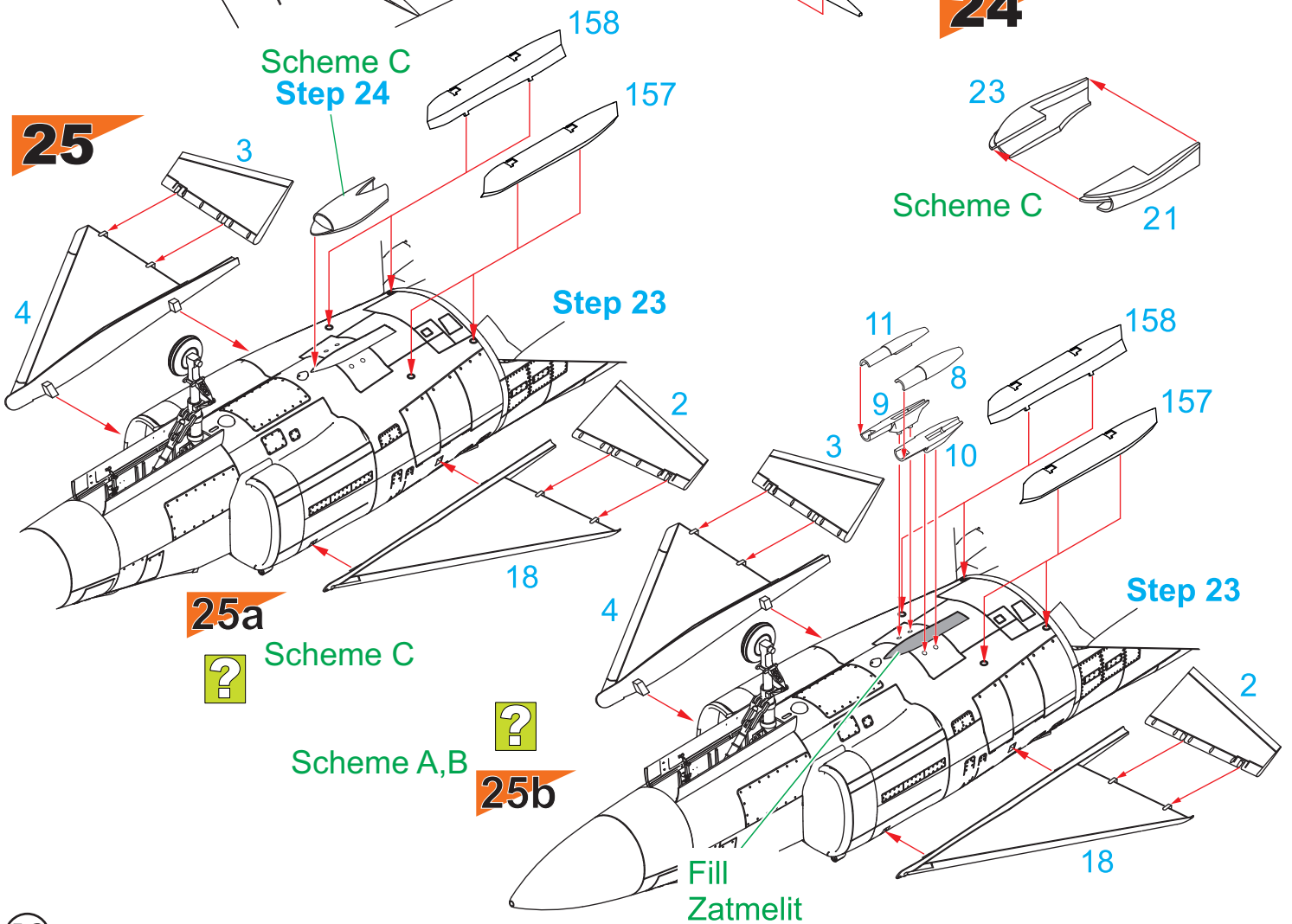

**25a**



Scheme C

Scheme A,B

**25b**



Fill  
Zatmelit

**12**

**26** ?

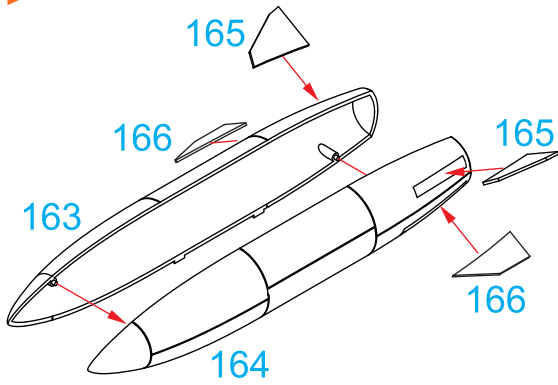

? Step 26

Step 27 ?

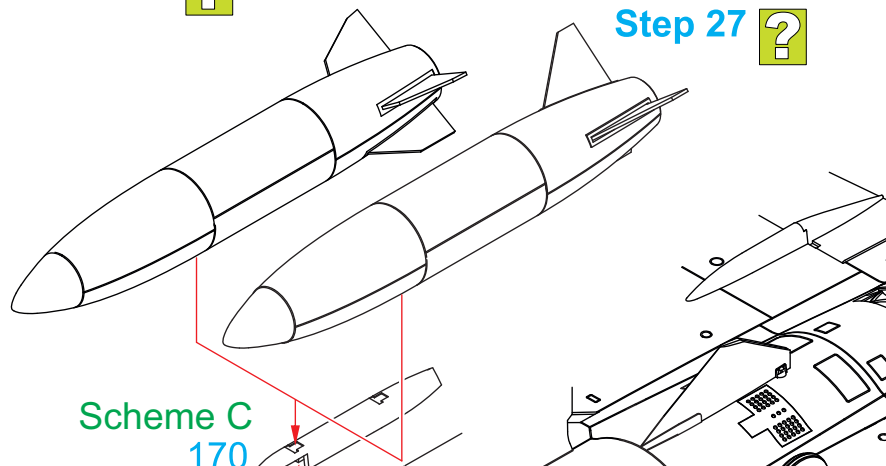

**29**

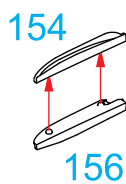

**28**

? 14

**28a**

13

Scheme C  
170

**30**

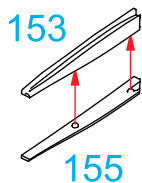

155

Step 25a

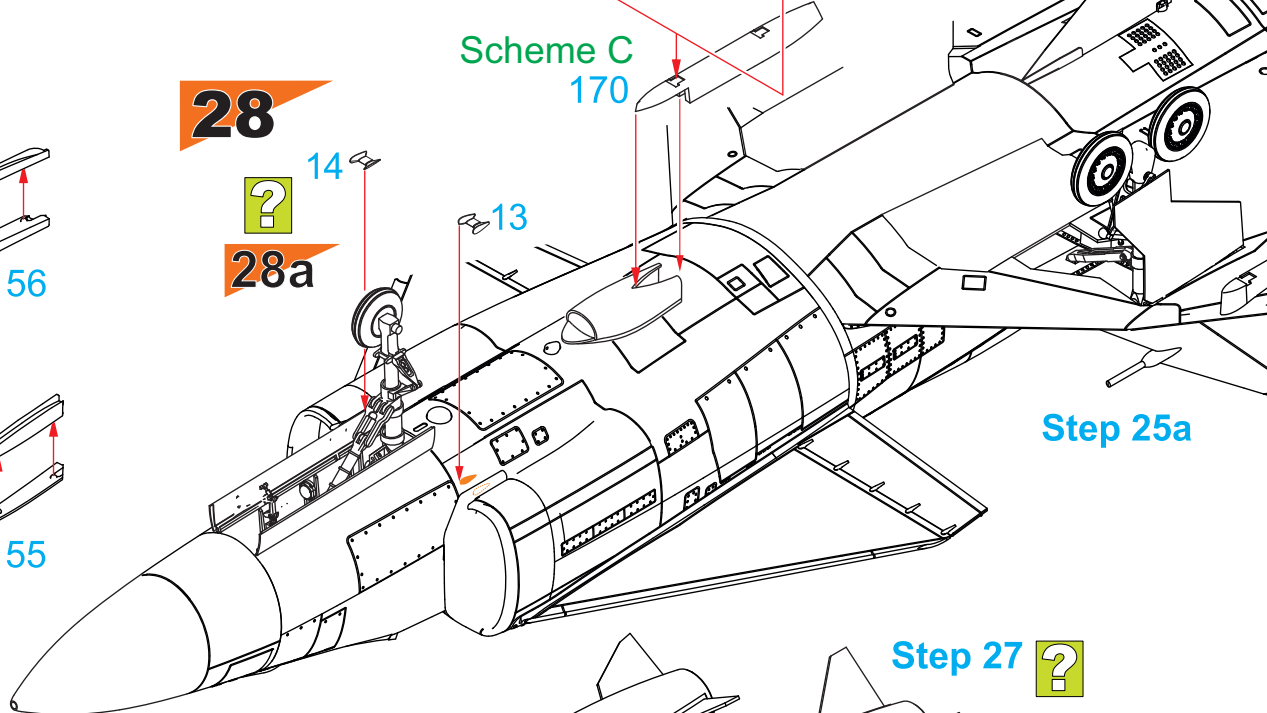

Step 27 ?

? Step 26

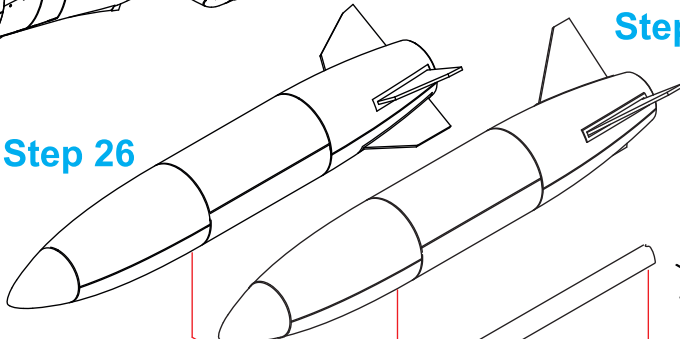

**27** ?

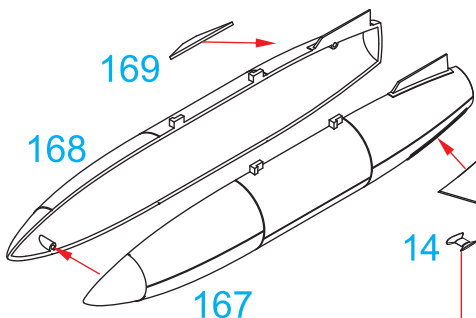

Scheme A,B  
1

? 14

**28b**

13

Step 25b

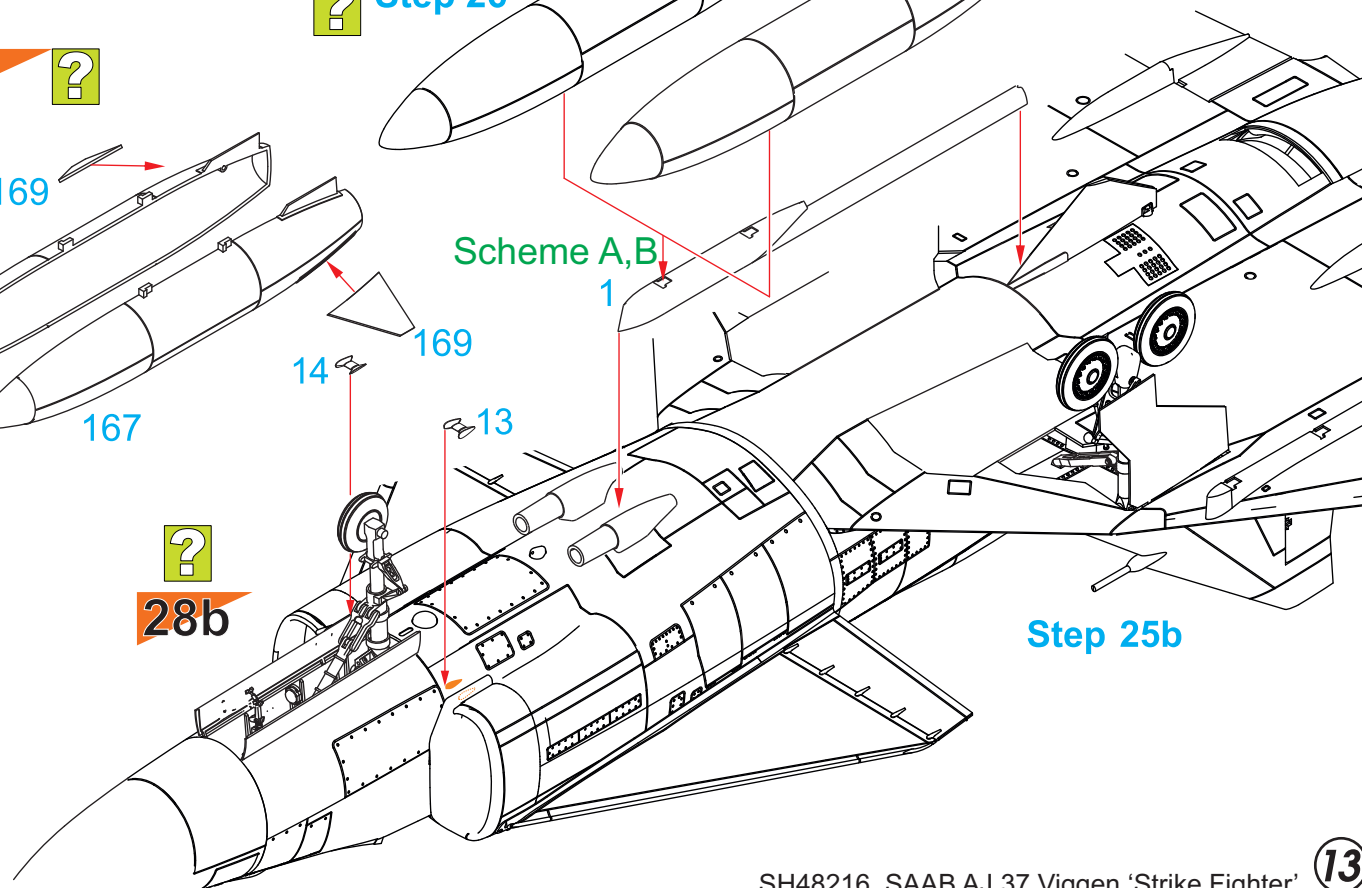

**31**

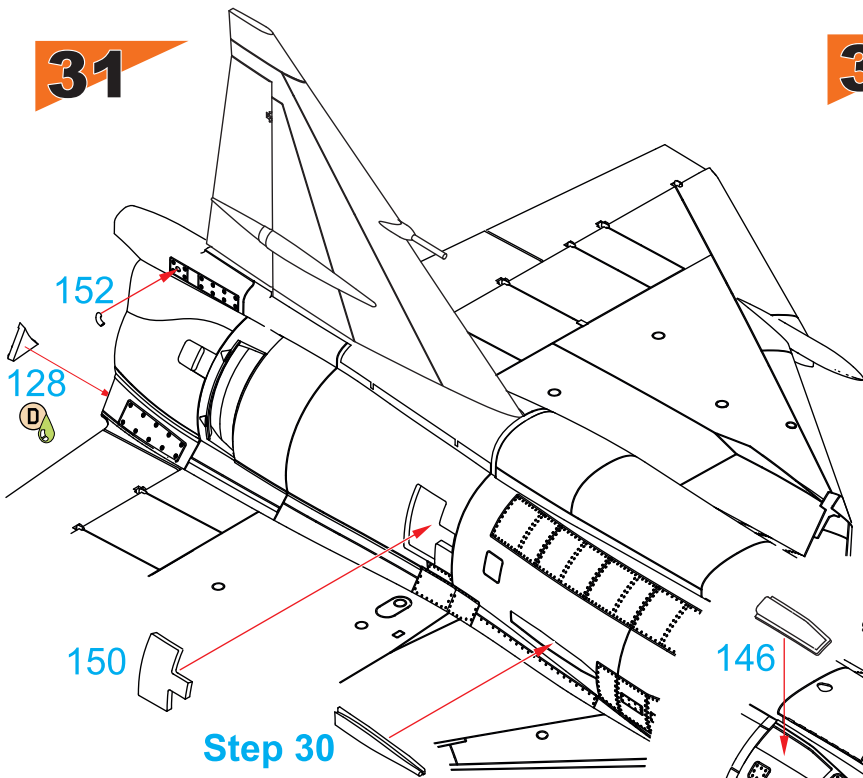

**33**

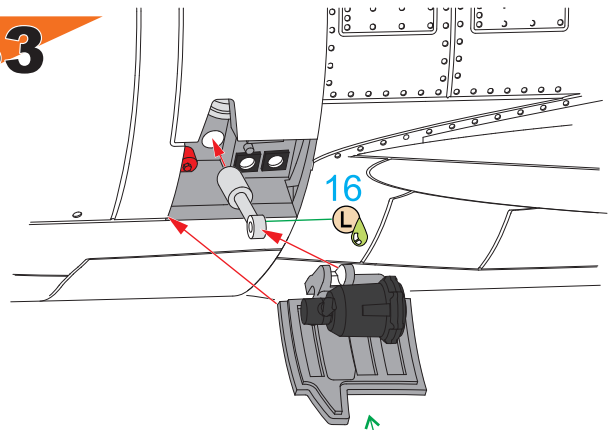

**32**

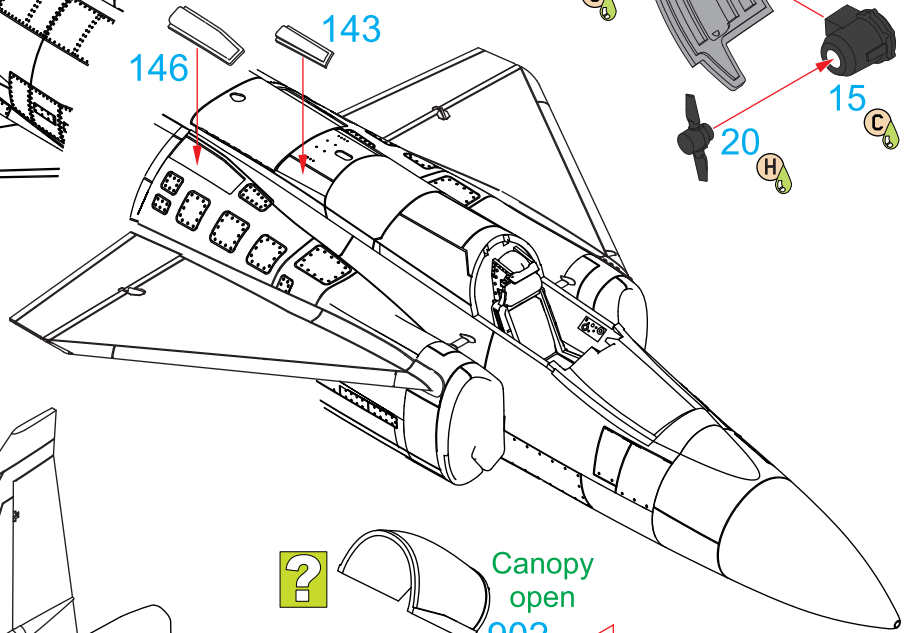

**34**

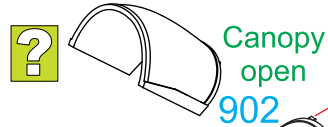
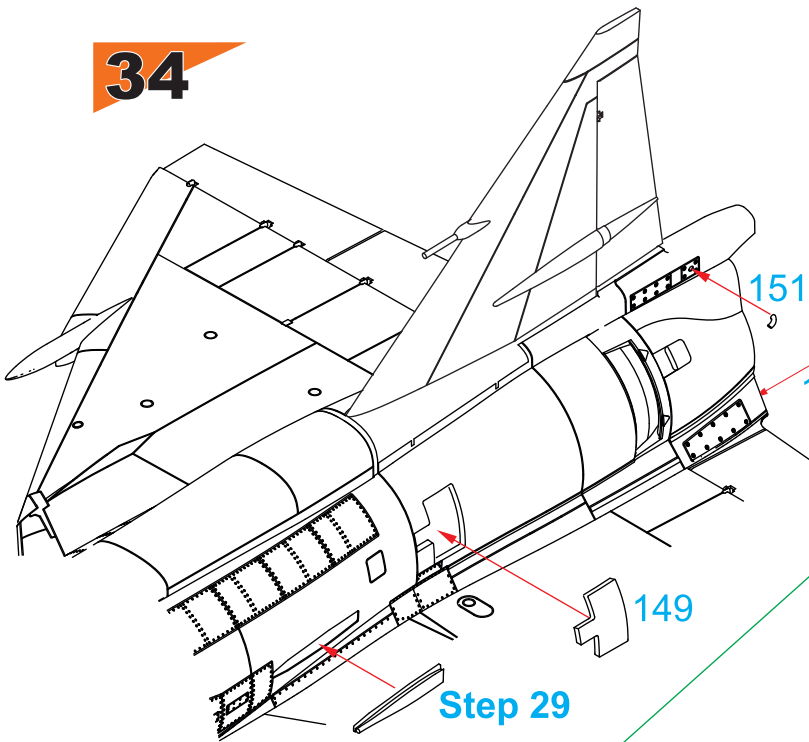

**35**

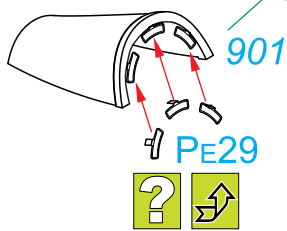
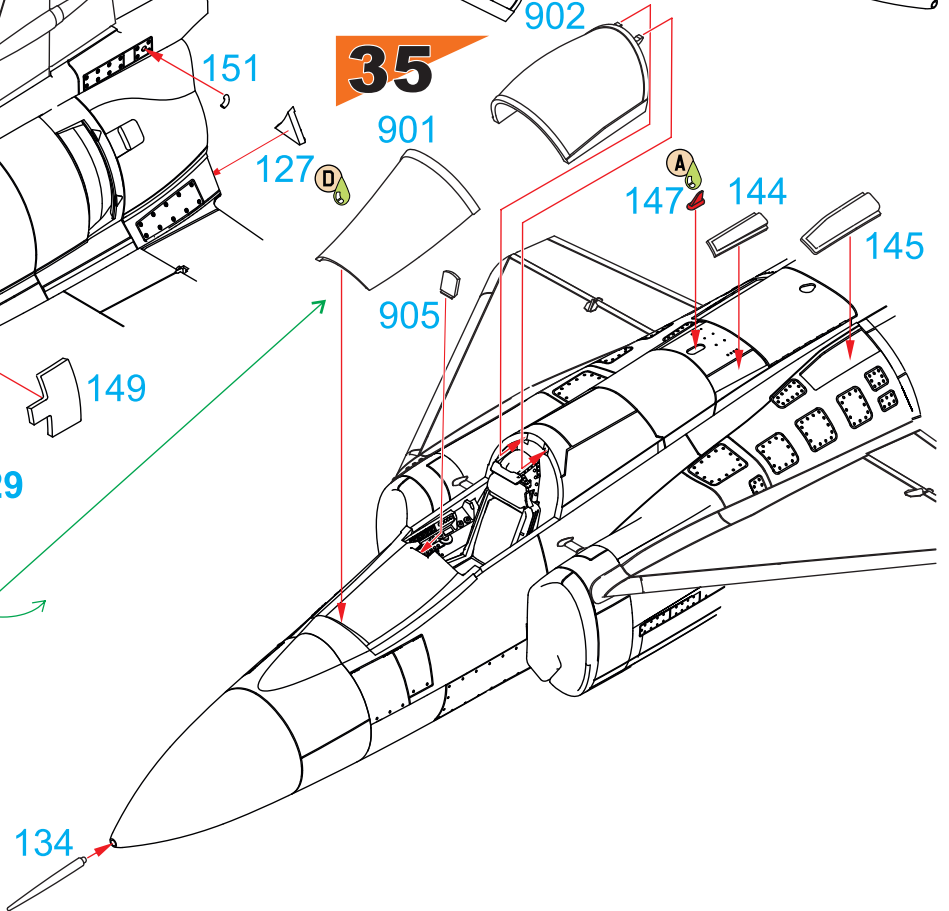

AJ-37 Viggen 37023/7-23/418, Wing F7, základna Sätenäs, červenec 1973. Stroj létající v barvě kovu nesl na trupu číslo 418, které dostal pro předvádění na Paris Air show 1973 o měsíc dříve. Při návratu do Švédska přistál 7-23 na holandské základně Leeuwarden pro doplnění paliva. Příslušníci tamější No.323 Squadrony RNLAF ozdobili levou stranu SOP 7-23 znakem své squadrony. 7-23 měl namontován pod trupem kíl typický pro první vyrobené kusy AJ 37 a byl vybaven dvěma nasávací pod trupem.

AJ-37 Viggen 37023/7-23/418, Wing F7, Sätenäs, July 1973. The bare-metal machine wore fuselage number 418 which she had got for her appearance at the 1973 Paris Air Show the month before. While on her route back to Sweden, 7-23 landed in the Netherlands on Leeuwarden air force base to refuel and the personnel of RNLAF No.323 Squadron adorned the port side of the tail fin with the badge of their unit. 7-23 was fitted with the ventral fin standard for the early production AJ 37s and also had a pair of belly air intakes.

### Scheme A

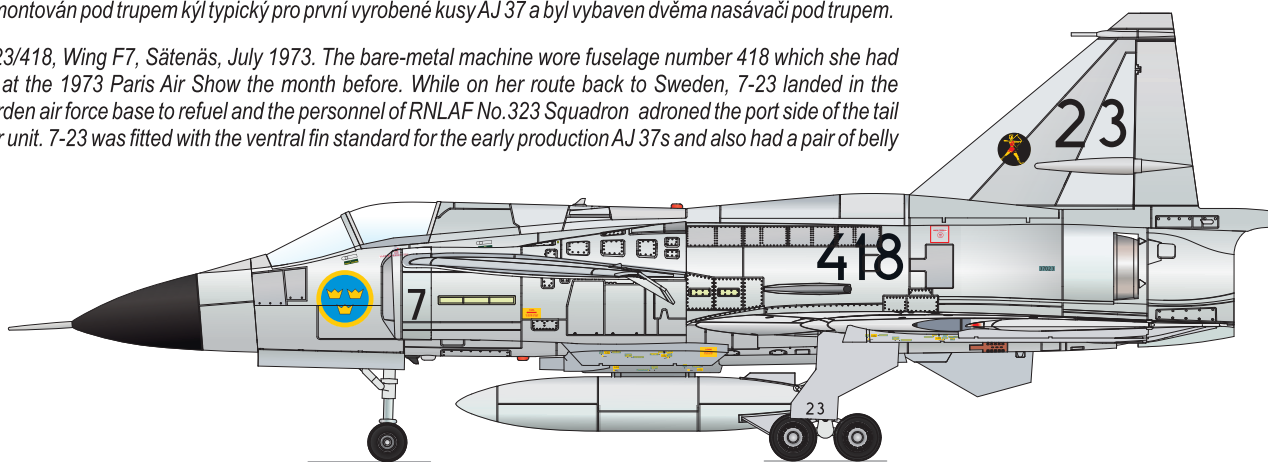

AJ-37 Viggen 37029/7-29, Wing F7, základna Sätenäs, červenec 1975. Znaky na trupu a SOP jsou památkou na účast tohoto stroje na Air show v tehdy západoněmeckém Buchelu, v září 1973. 7-29 měl namontován pod trupem kíl typický pro první vyrobené kusy AJ 37 a byl vybaven dvěma nasávací pod trupem.

AJ-37 Viggen 37029/7-29, Wing F7, Sätenäs, July 1975. The emblems on the fuselage and the tail fin commemorate this machine's appearance at the September 1973 Air Show at Buchel in the then West Germany. 7-29 also featured the early production style ventral fin and two belly air intakes.

### Scheme B

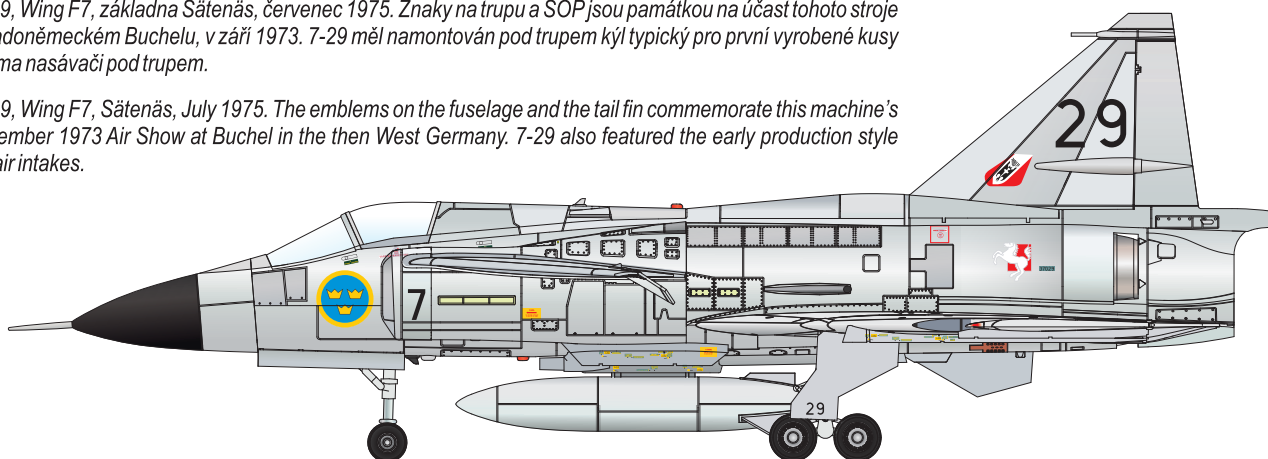

AJ-37 Viggen 37035/6-35, Wing F6, základna Karsborg, září 1984. Povrch stroje byl opotřebovaný, stejně jako číslo 35 na SOP. 6-35 měl namontován pod trupem kíl typický pro pozdější vyrobené kusy AJ 37 a byl vybaven jedním nasávacím pod trupem.

AJ-37 Viggen 37035/6-35, Wing F6, Karlsborg, September 1984. The exterior of the machine, as well as number 35 on the tail fin are rather worn down. 6-35 already sported the ventral fin of the variety normal for all the later AJ 37s and had just one air intake under her belly.

### Scheme C

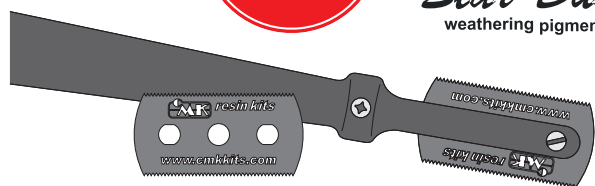
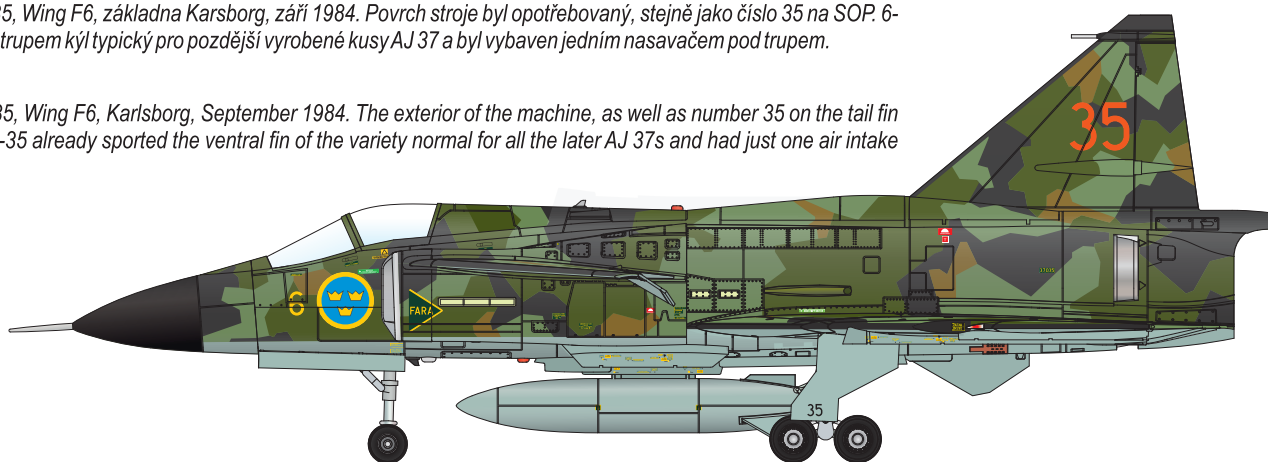

**The Razor Saw with Handle (cat. n. H1010) is a great tool for cutting both plastic and resin. CMK also offers a wide variety of coarse/medium/fine saws.**

**H1000** Ultra smooth and extra smooth saw (2 sides – 70 teeth / 42 teeth) 1 pc

**H1001** Ultra smooth saw (both sides – 70 teeth / 70 teeth) 1 pc

**H1002** Very smooth saw (both sides – 42 teeth / 42 teeth) 1 pc

**H1003** Smooth saw (both sides – 31 teeth / 31 teeth) 1 pc

**H1004** Ultra smooth and extra smooth saw (2 sides – 70 teeth / 42 teeth) 5 pcs

**H1005** Ultra smooth saw (both sides – 70 teeth / 70 teeth) 5 pcs

**H1006** Very smooth saw (both sides – 42 teeth / 42 teeth) 5 pcs

**H1007** Smooth saw (both sides – 31 teeth / 31 teeth) 5 pcs

**H1010** Razor Saw with Handle

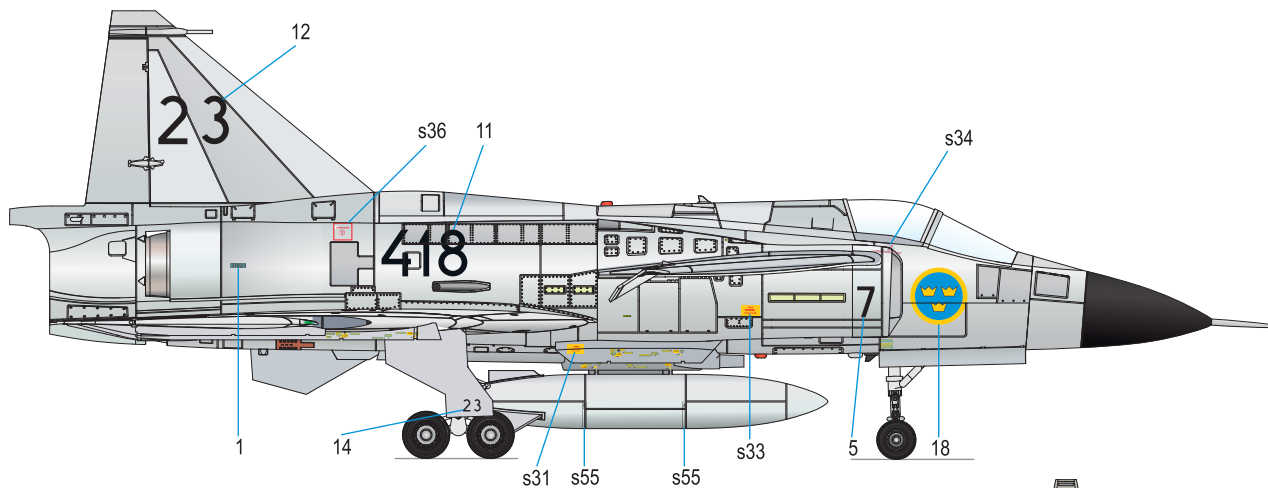

Natural Metal Finish  
Přirodní kov  
H8/C8

Black  
Černá  
H12/C33

Light Grey  
Světle šedá  
H324/C324

Red Brown  
Červenohnědá  
H47/C41

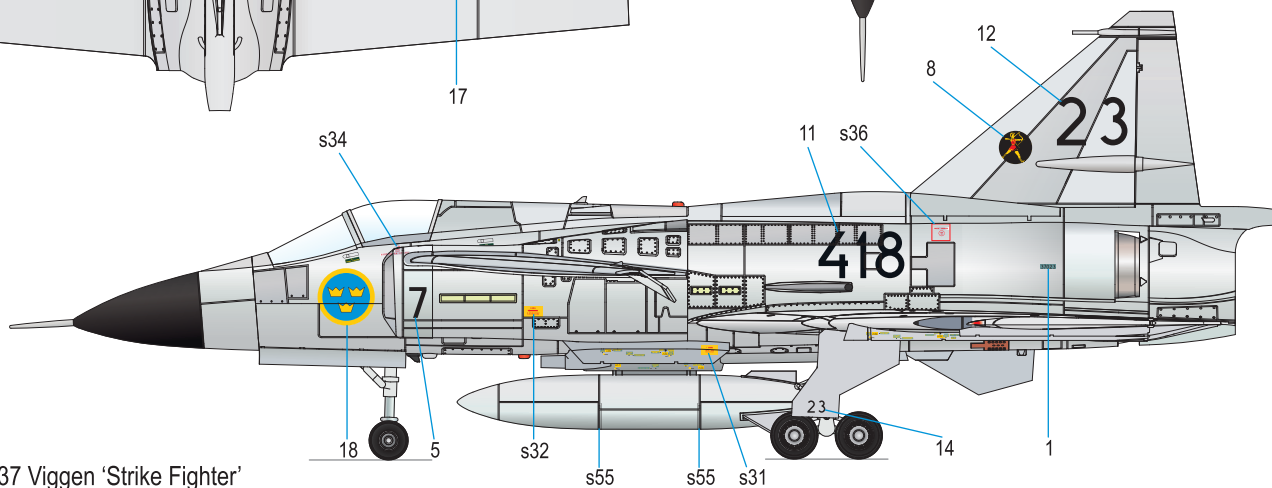
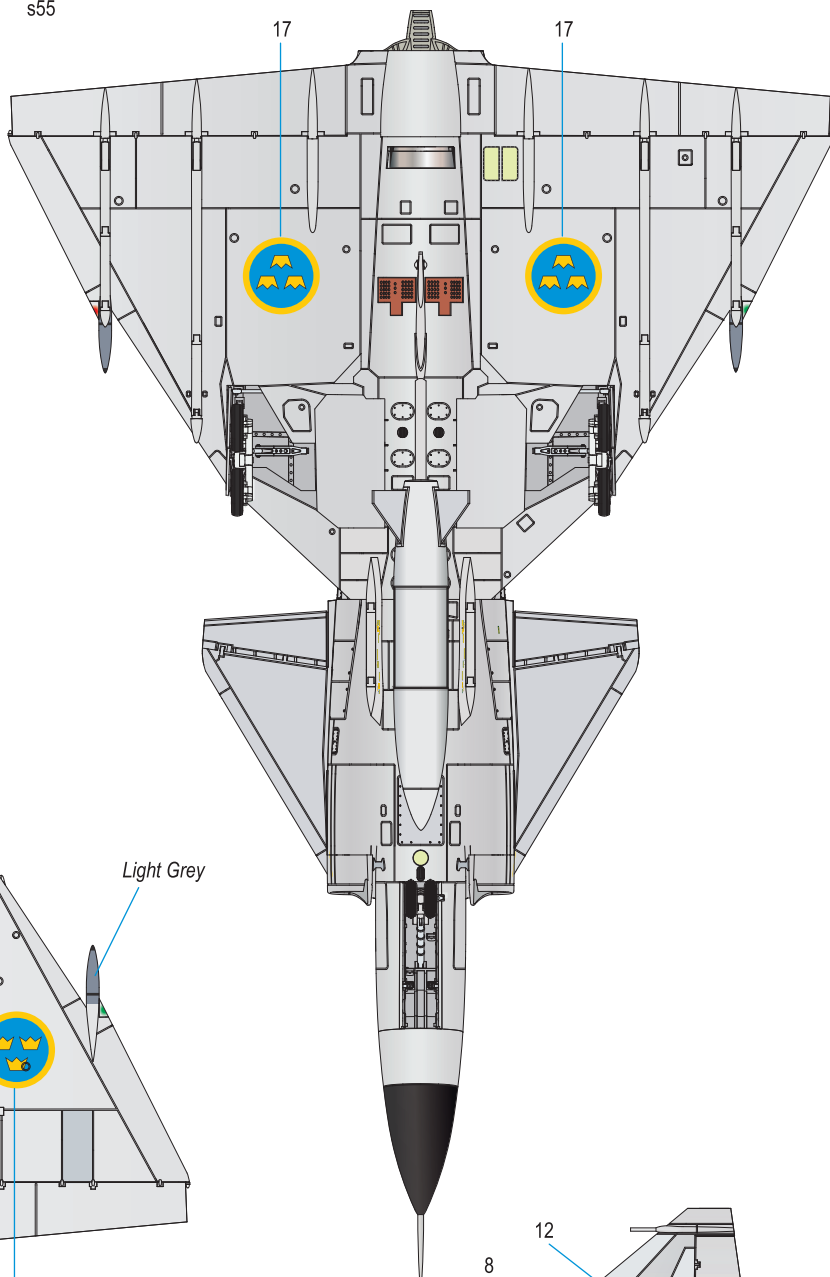
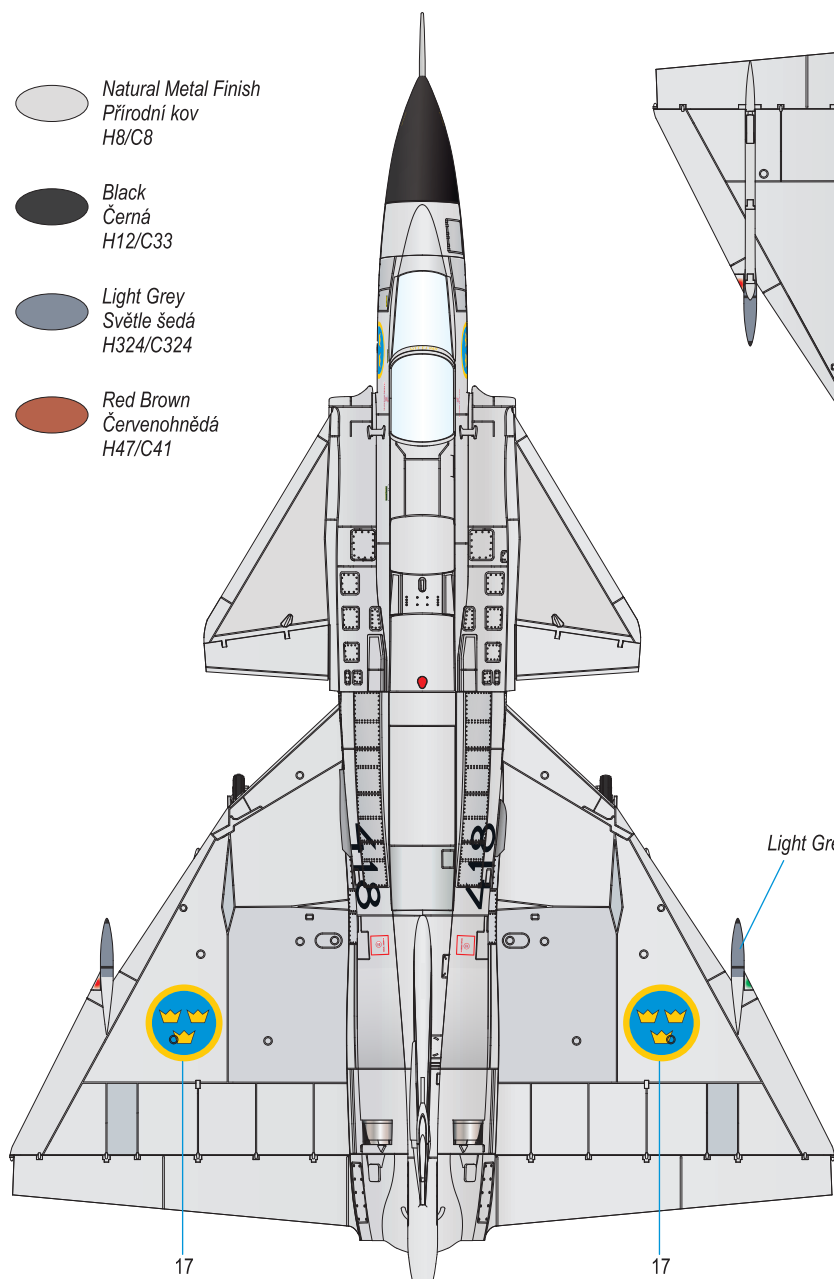



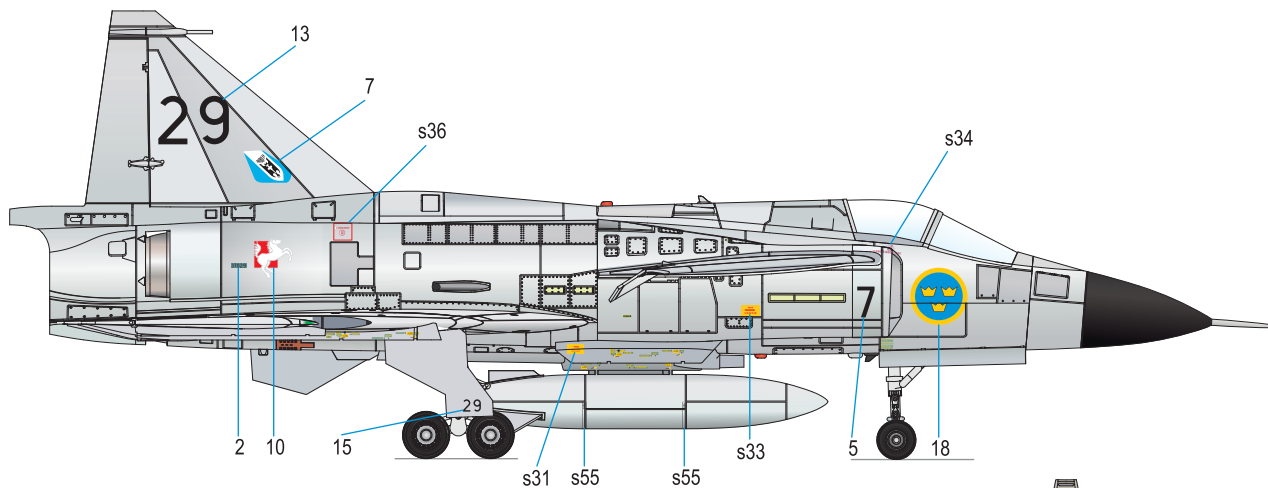

 Natural Metal Finish  
Přirodní kov  
H8/C8

 Black  
Černá  
H12/C33

 Light Grey  
Světle šedá  
H324/C324



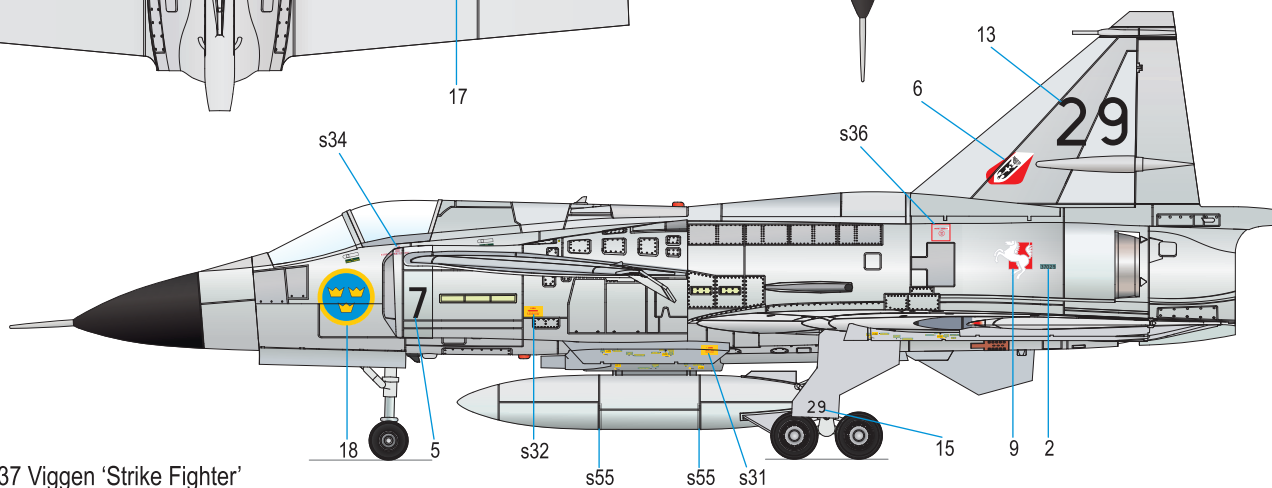
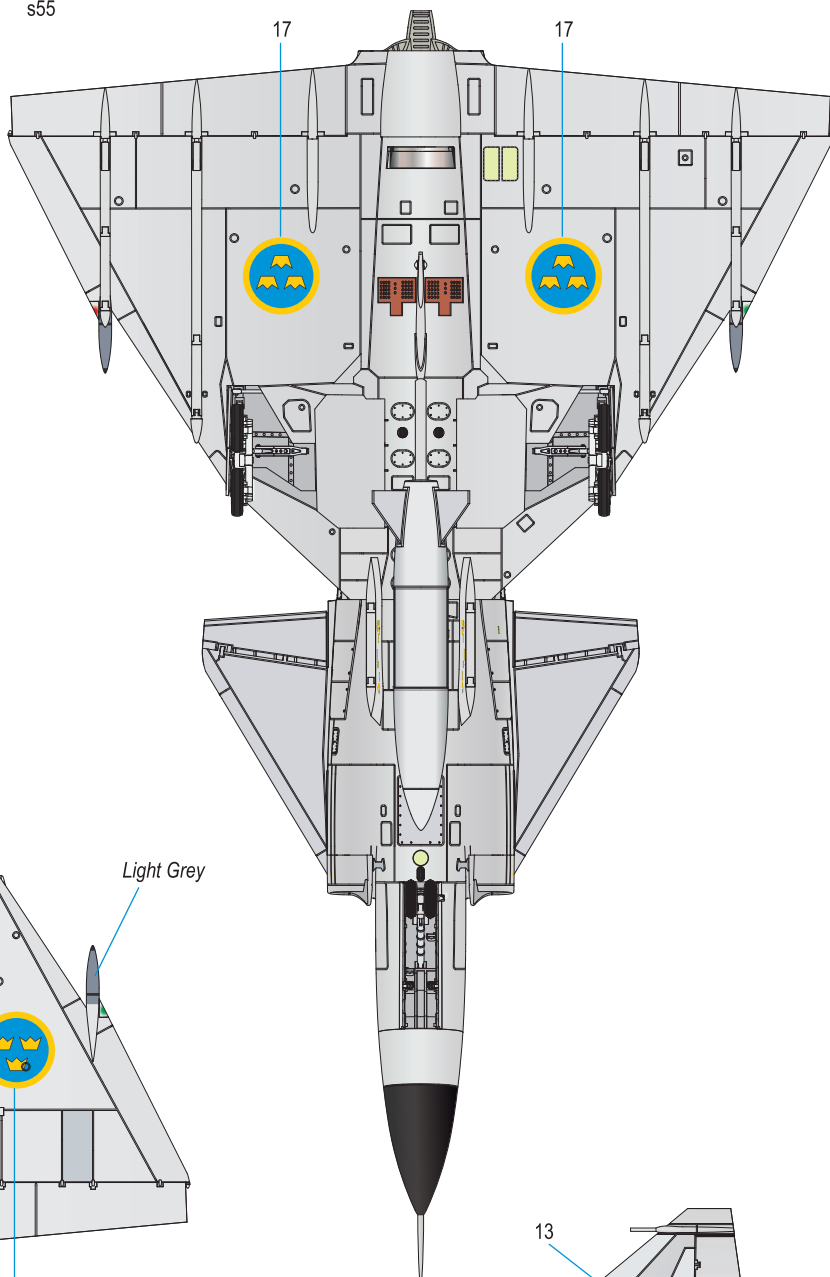
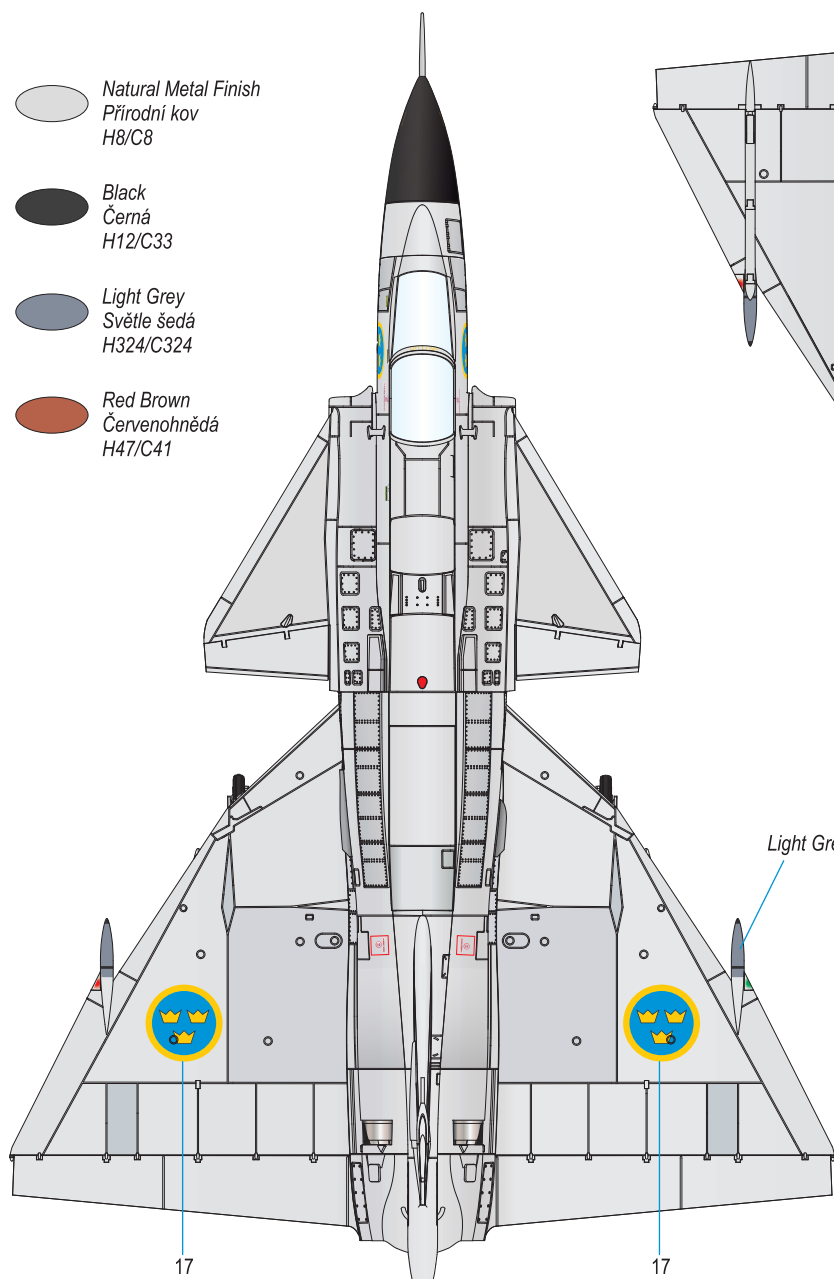



 Red Brown  
Červenohnědá  
H47/C41

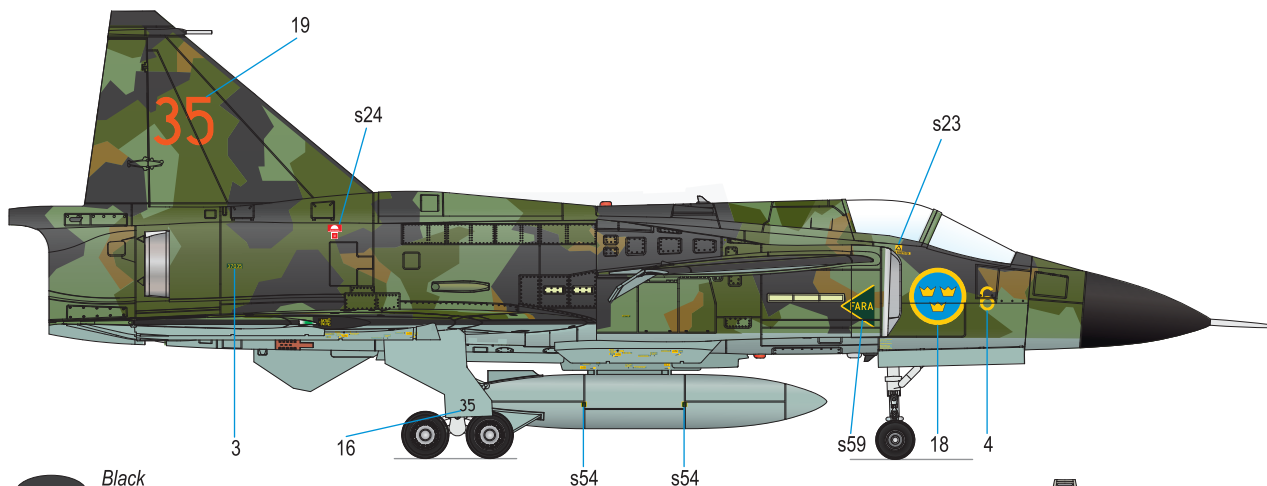

Special  
HOBBY

GUNZE  
SANGYO



-  Black  
Černá  
H12/C32
-  Dark Green  
Tmavě zelená  
H309/C309
-  Light Green  
Světle zelená  
H58/C27
-  Tan  
Světle hnědá  
H310/C310
-  Light Grey  
Světle šedá  
H308/C308
-  Red Brown  
Červenohnědá  
H47/C41
-  Aluminium  
Hliník  
H8/C8

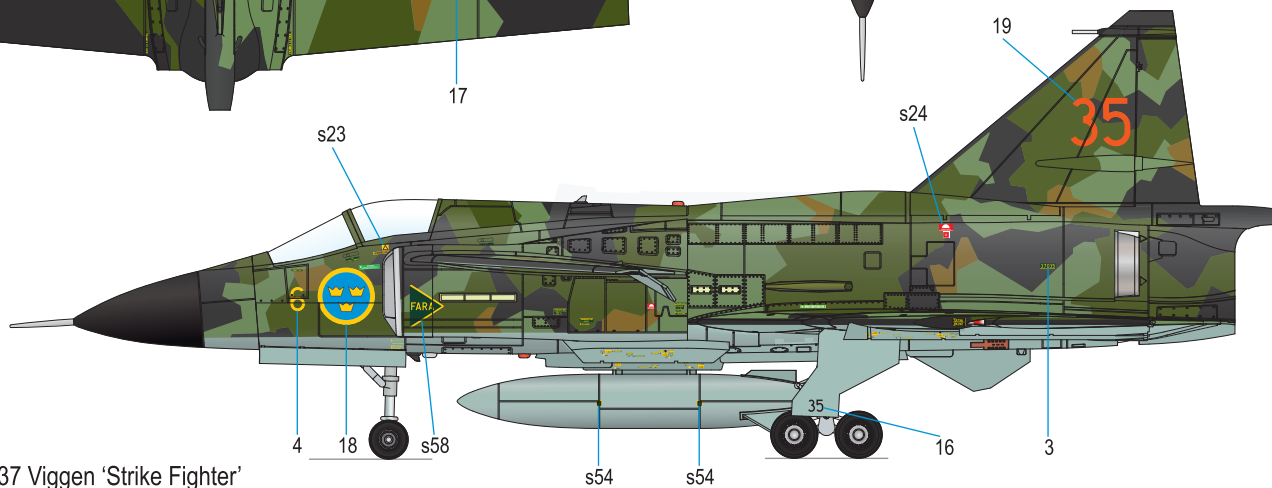
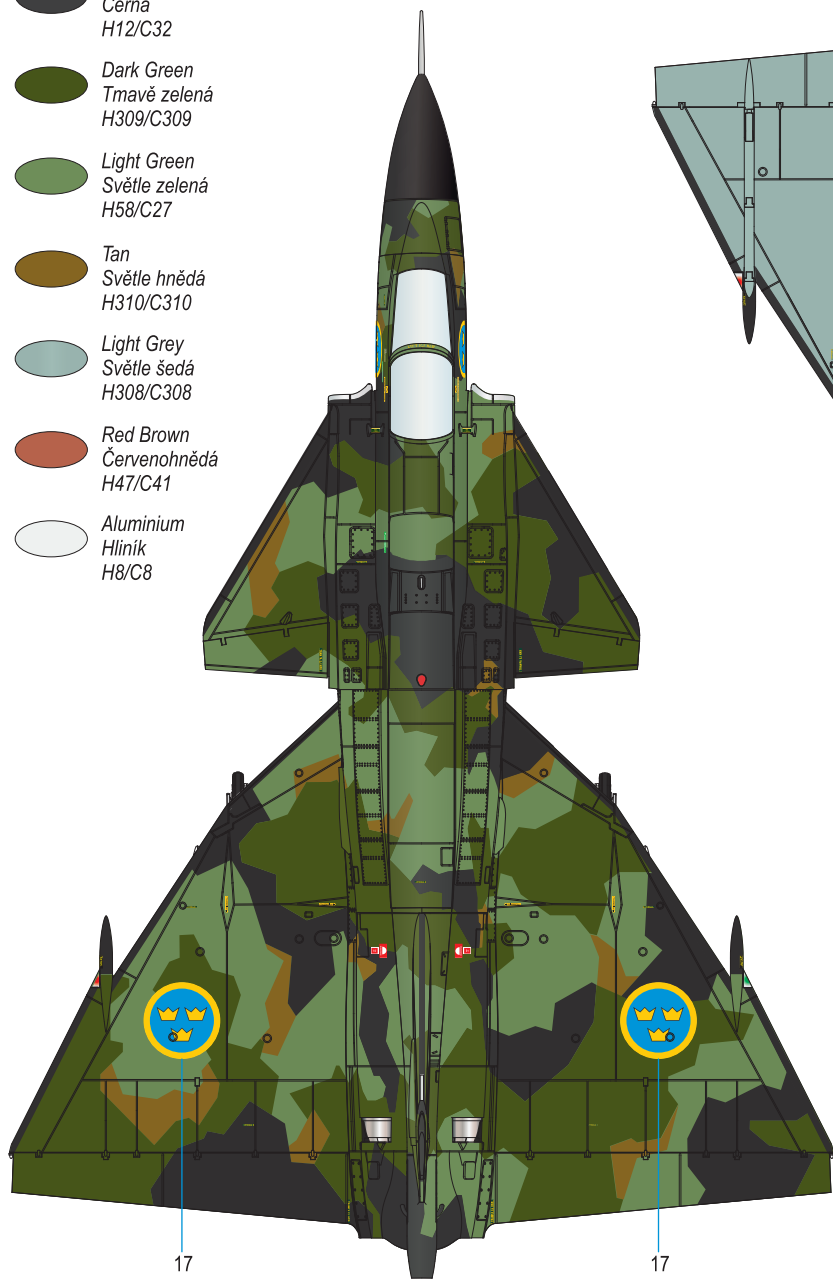
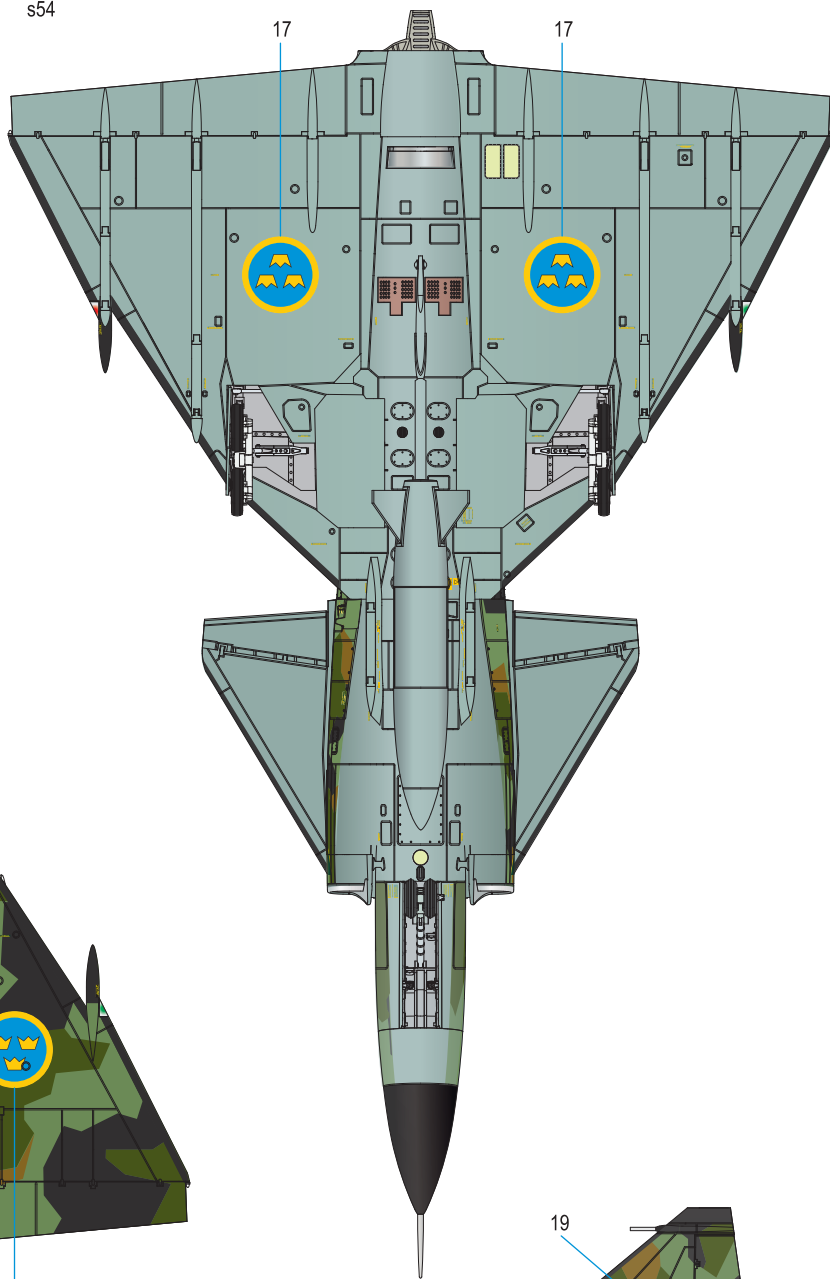

# Universal Stencil Placement Scheme

(note: some stencils may have not been used on your chosen machine, always check photos and marking schemes)

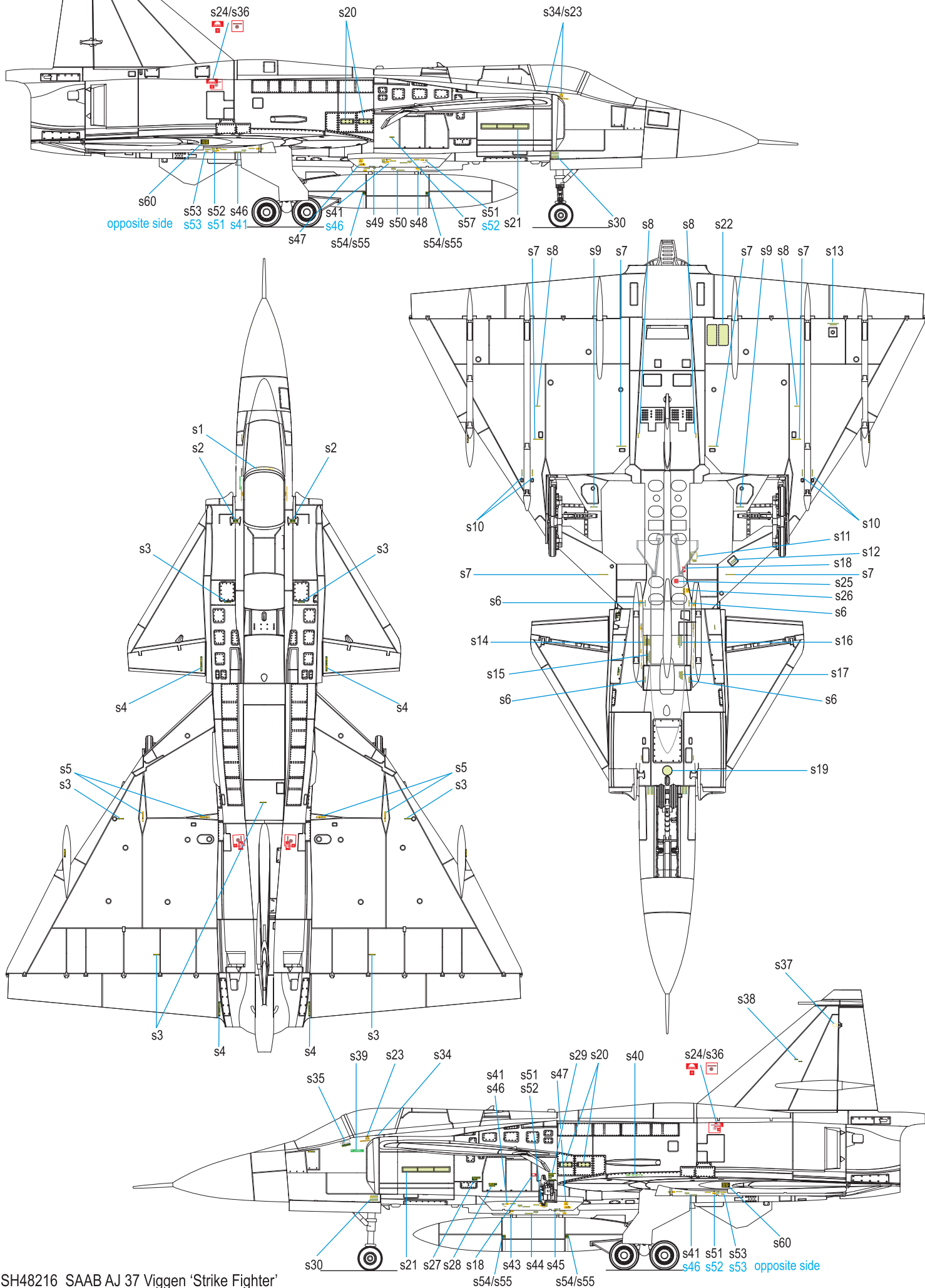

# VIGGEN CMK RESIN SETS for Special Hobby kits



**4310**  
Bofors m/70  
Rocket pod (2 pcs)



**4385**  
AJ/SK/SH-37 Viggen  
Control Surfaces

**Q48219**  
Viggen  
Ejection  
Seat



**Q48220**  
SAAB 37 Viggen  
Air Brakes Set



**Q48221**  
SAAB 37 Viggen  
Wheels



**Q48350**  
SAAB 37 Viggen  
Thrust Reverser



**F48350**  
SK-37/SK-37E  
Viggen Instructor/  
Operator (seated  
in rear cockpit)



**F48360**  
Viggen Ground  
Crew (2 figs.)



**F48351**  
AJ-37/JA-37  
Viggen Pilot  
Climbing Ladder  
into Cockpit



**1/48**  
**SH48202**

**M48005 AH-1G Cobra MASK**

**AH-1G Cobra 'Spanish & IDF/AF Cobras'**